

x1 Collaboration Wallboard

SIZE GUIDE & CONTENTS FOR Collaboration Wallboard

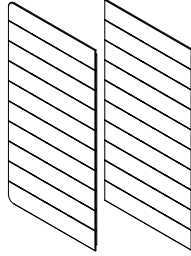

1207mm x 2413mm
[47.5in x 95in]

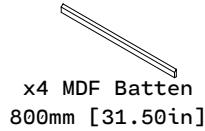

x4 MDF Batten
800mm [31.50in]

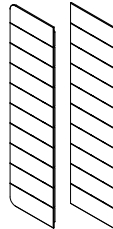

603mm x 2413mm
[23.75in x 95in]



x4 MDF Batten
400mm [15.75in]

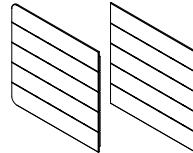

1207mm x 1207mm
[47.5in x 47.5in]

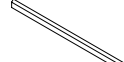

x2 MDF Batten
800mm [31.50in]

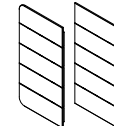

603mm x 1207mm
[23.75in x 47.5in]



x2 MDF Batten
400mm [15.75in]

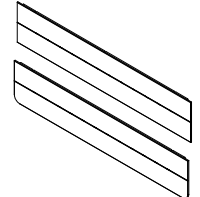

2413mm x 483mm
[95in x 19in]

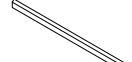

x4 MDF Batten
800mm [31.50in]

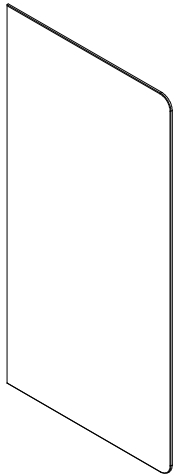

x1 Collaboration Whiteboard

SIZE GUIDE & CONTENTS FOR Collaboration Whiteboard

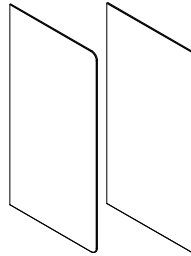

1207mm x 2413mm
[47.5in x 95in]



x4 MDF Batten
800mm [31.50in]

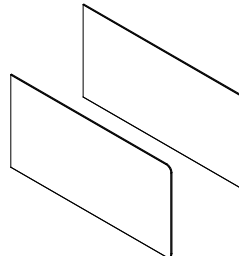

2413mm x 1207mm
[95in x 47.5in]



x4 MDF Batten
800mm [31.50in]

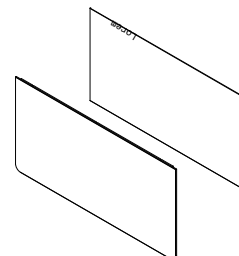

2413mm x 1207mm
[95in x 47.5in]



x4 MDF Batten
800mm [31.50in]

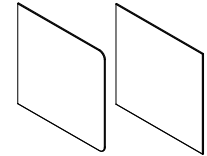

1207mm x 1207mm
[47.5in x 47.5in]

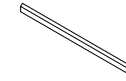

x2 MDF Batten
800mm [31.50in]

CAUTION

- Clear open space for install
- Installer is responsible for installing Z clips to the wall.
- + 25lbs lift required

Tools you will need:



Laser Level



Tape Measure



Electric Drill



Spirit Level

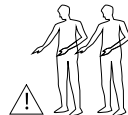

Two Person Install

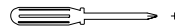

Phillips Head Screw Driver



Suitable Screws For Different Surfaces
Screws Are Not Included

1

Prepare your MDF Battens before measurement. Drill holes on MDF Battens suitable for you selected screws (Screws For Different Surfaces). Two holes per MDF Batten required. Before drilling check the surface for obstacles.

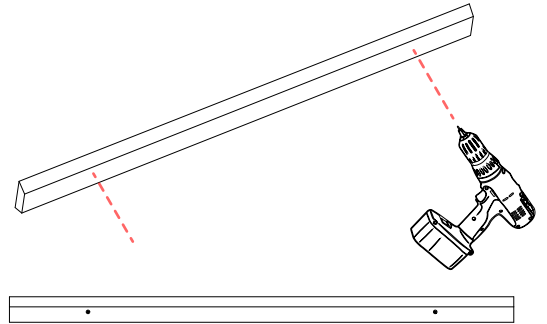

2

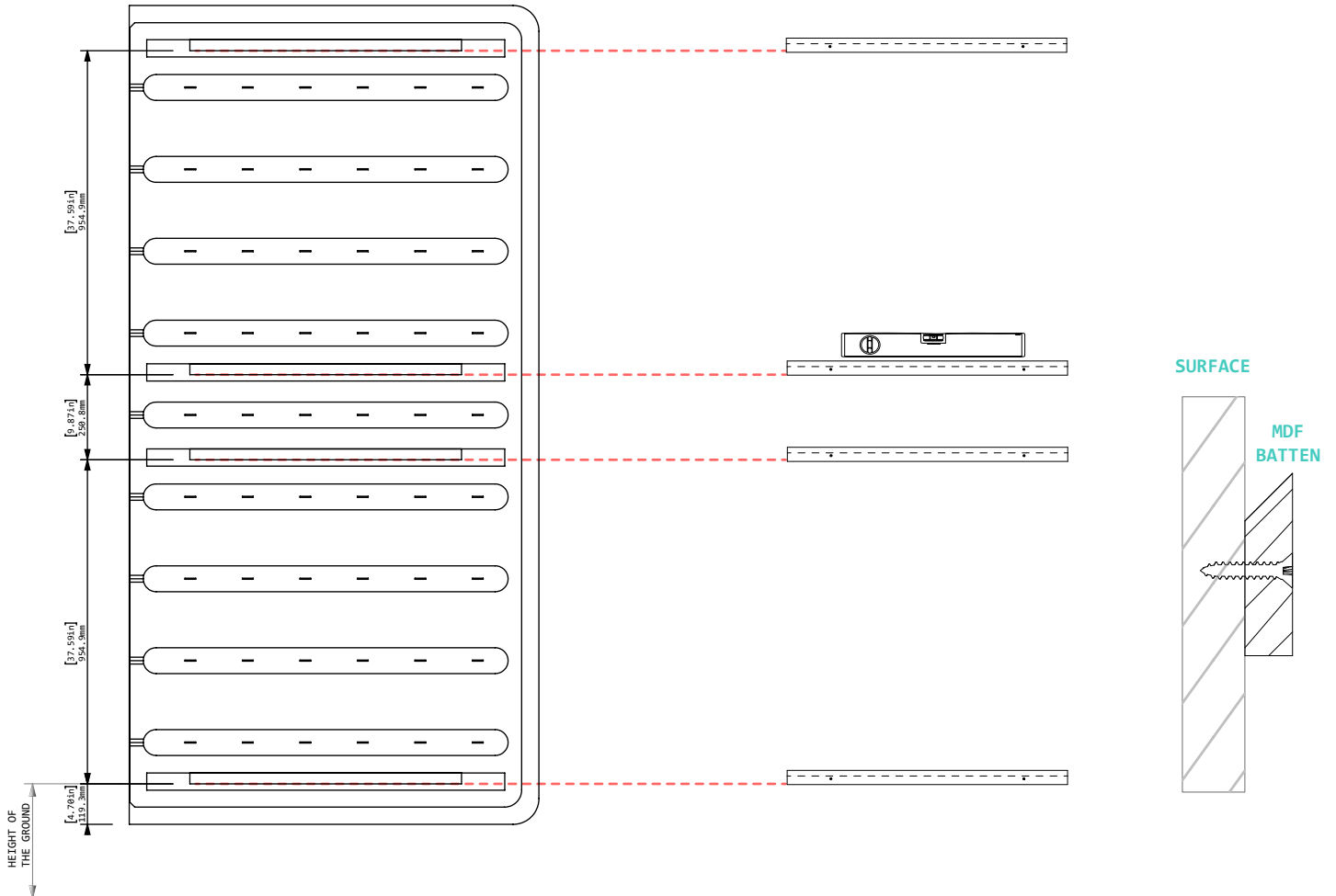

a. Insert MDF Battens into Collaboration Wallboard. Measure from the floor to the desired height of the bottom MDF Batten. See drawing above.

b. Match Collaboration Wallboard spacing onto your solid wall (Surface). Ensure MDF Battens are the correct direction and level. Check with a laser or spirit level. Installer to use fixings appropriate to Solid wall construction.

3

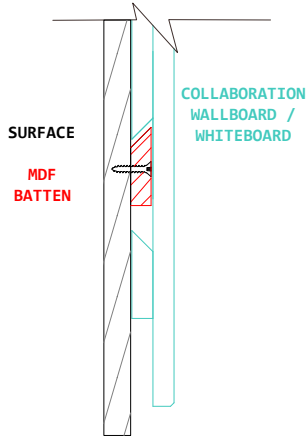

Gravity



CAUTION

Installer is responsible for installing MDF BATTENS to the wall. Ensuring they are structurally sound to hang a Collaboration Wallboard / Whiteboard and desired accessories.

a. Ensure MDF Battens are correct direction for installation. Also make sure the screws are flush as they will interfere with acoustic PET panel.

4

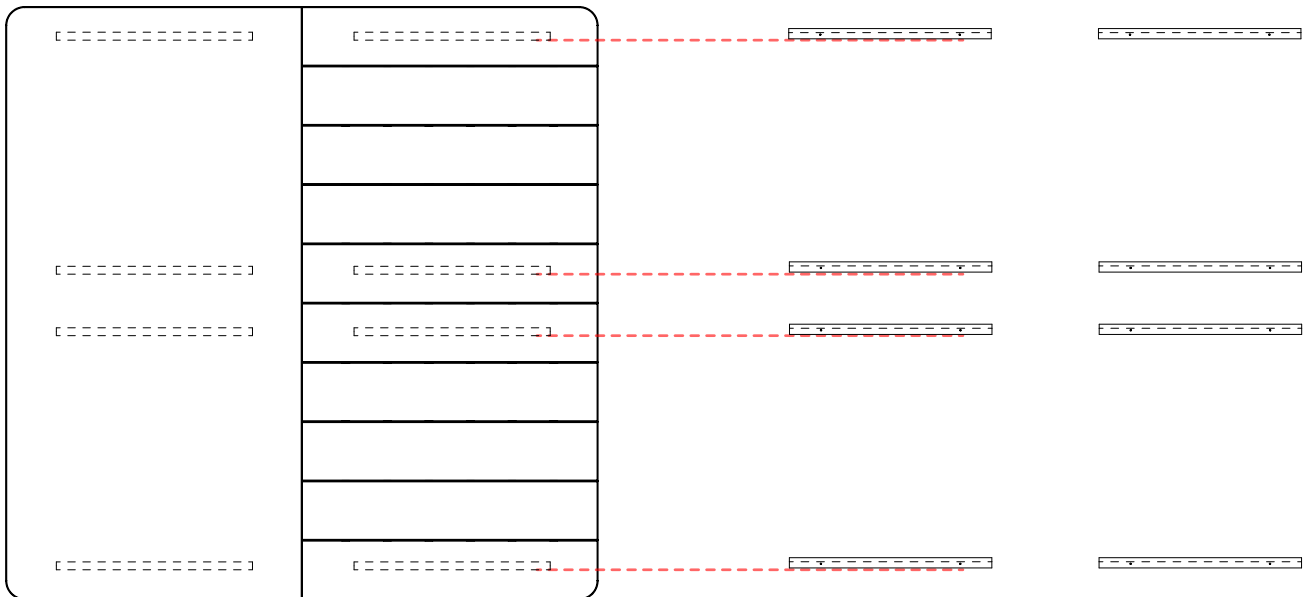

GROUND LINE

a. When installing multiple Cooee Collaboration Wallboards / Whiteboards, laser level is recommend as the floor or ceiling may not be level. This will warrant any mis-alignment and help in a fast and accurate install.

5

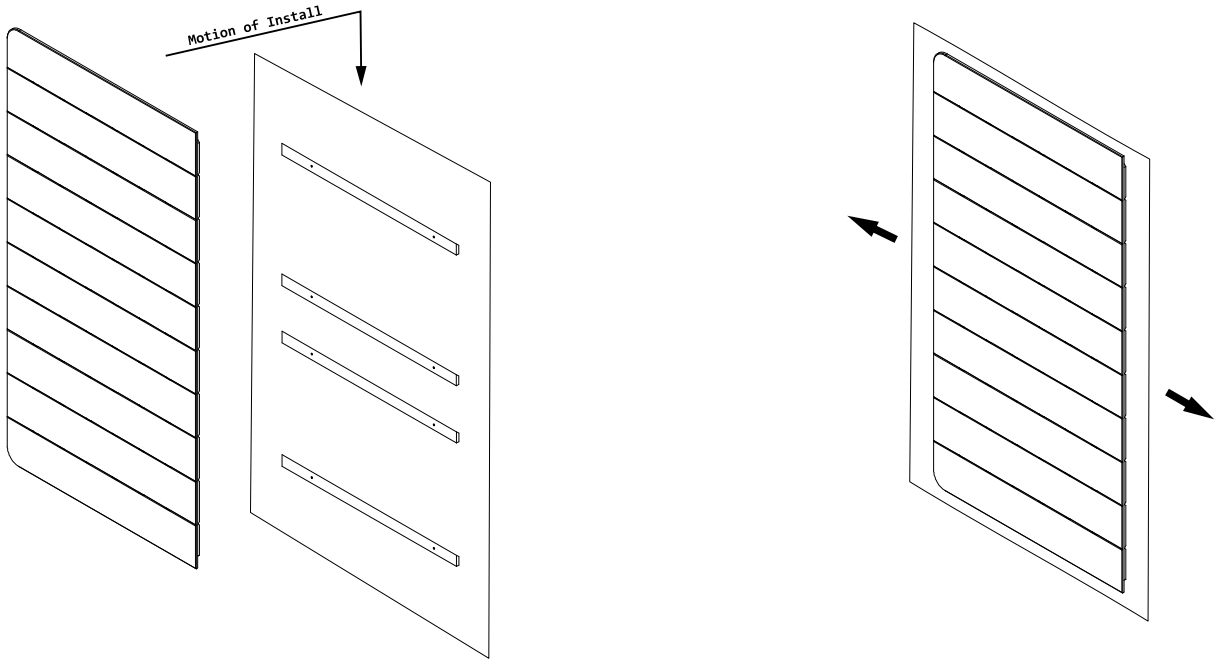
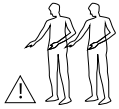

a.
Once MDF Battens are secure on the solid wall, the Cooee Collaboration Wallboard / Whiteboard can be lifted in place. This requires 1-2 people. Make sure pressure is applied at the front of the acoustic PET to ensure MDF Battens and Wallboard lock into each other.

b.
Once Cooee Collaboration Wallboard is lifted in place. Make sure it is centered over the MDF Battens. Slight adjustments on both sides is possible.

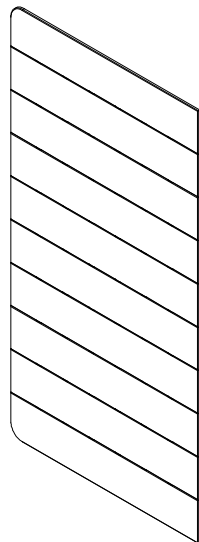

x1 Assembled
Collaboration
Wallboard

OR

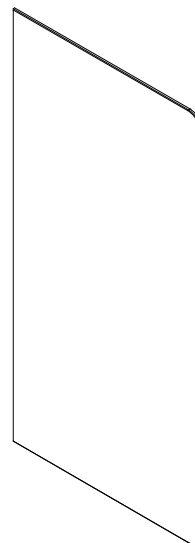

x1 Assembled
Collaboration
Whiteboard