

CONTENTS FOR Cooee Three Quarter With Power

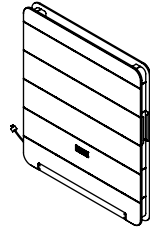

x1
Cooee Three Quarter
Wall With Power

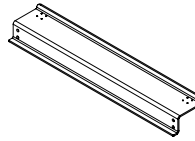

x2
Metal Base
Plates

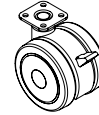

x4
Lockable
Castors



x16
M4 Countersunk
Bolts



x4
3/8"
Flange Nut



x16
M4
Flange Nut



x8
3/8" Washer

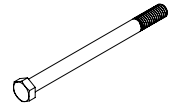

x4
3/8" 5" Long
Hex Bolt

x1 Cooee Three Quarter Wall With Power

CAUTION

- Clear open space for install
- May need need a sturdy table.
- + 50lbs lift required

Tools you will need:

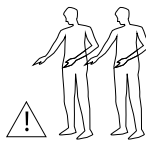

Two Person
Install



7mm Spanner



15/16" Spanner

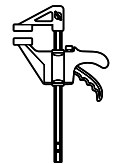

Quick grip

1

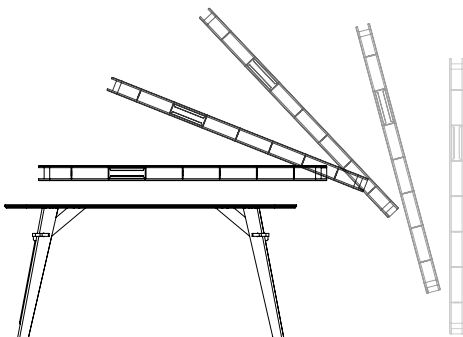

a.
Lay Cooee Wall on table.

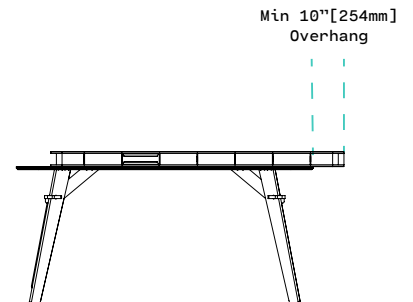

b.
Hang bottom end off the table
to allow for base assembly.

2

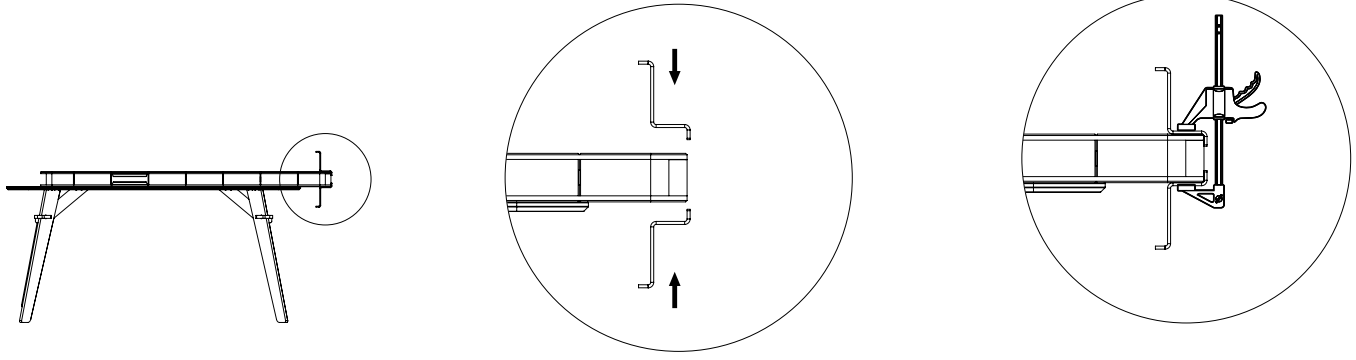

a.
Lay metal bases on Cooe Wall.

b.
Clamp with quick grip.
Ensure Holes are aligned.

3

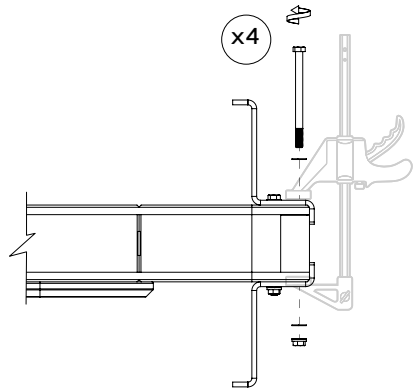

a.
Insert 3/8 bolt, Washer and Flange Nut.
Ensure all bolts are in the same direction

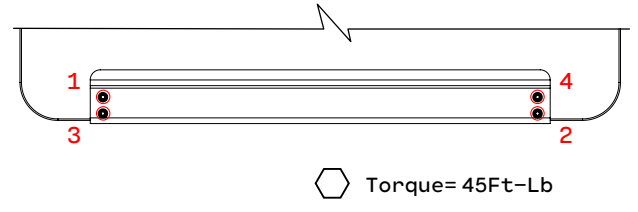

b.
Clamp with quick grip. Tighten bolts in order and repeat to prevent one bolt tighter than the other.
Ensure Hole's are aligned.

4

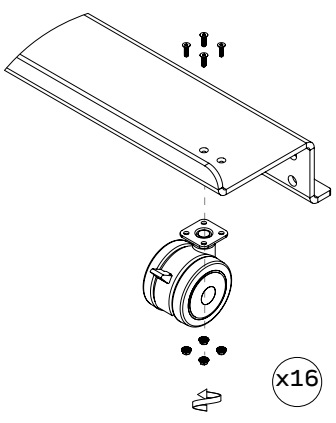

a.
Insert countersunk bolts, castors and M4 Flange nuts then tighten with 7mm Spanner.
Repeat for all bolts

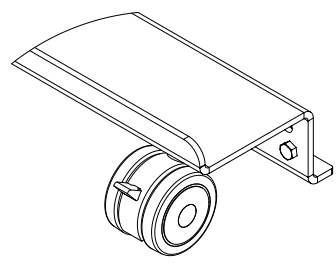

b.
Ensure all bolts and castor's are secure

5

 2 Person Lift

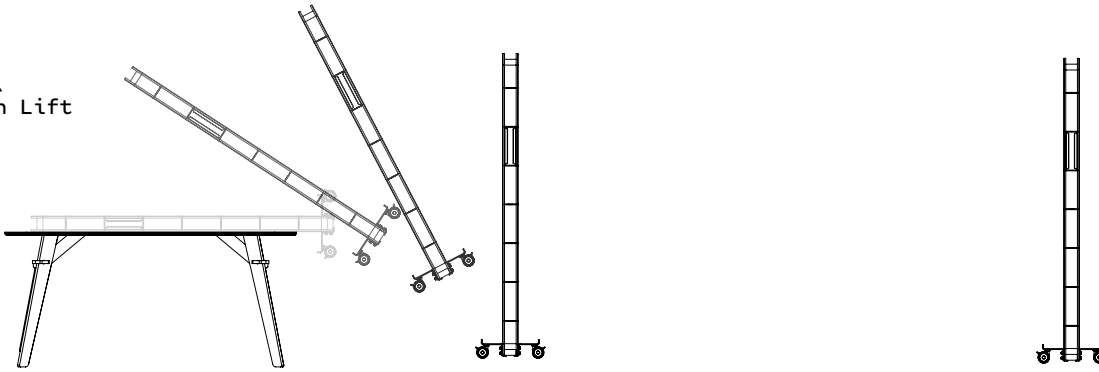

a.
Lift Cooee Wall onto the ground.

b.
Stand up and ensure Cooee Wall is able to move and castors can be locked.

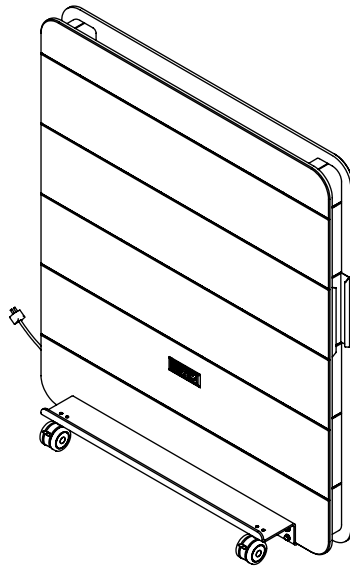

x1 Assembled
Cooee Three Quarter Wall With



CAUTION & WARNING STATEMENT.

- Ensure wheels are locked and stationary when attaching Accessories.
- Cooee Wall With Power has internal wiring and live power when plugged in.
- Do not screw or drill anywhere unless stated on the Func Assembly guide.
- Escape routes must not be blocked.
- Disconnect Power when moving.
- Move slow, especially when crossing door thresholds etc.
- Ensure all cables have no loops and are out of foot traffic. (No trip hazards)
- Do not load heavy accessories on one side of the wall, as it increases the chance of tipping.