

UPHOLSTERED

MALL, POD + PARENT SEATING

botton + gardiner
PUBLIC SPACE FURNITURE



About botton + gardiner

Botton + Gardiner is an Australian design and manufacturing company specialising in quality furniture and fixtures for public authorities, shopping centres, accommodation and hospitality industries. Botton + Gardiner provide the complete solution with a great range of standard product, an in-house design team to develop tailored furniture for projects and can take care of installation and placement of the finished items.

Established in 1995 and purchased by Baresque in 2013, Botton + Gardiner has successfully gained a significant position in domestic and export marketplaces for delivery of a high standard of product and service. Botton + Gardiner's range of Australian made products and offerings from overseas include urban furniture, banquette seating, litter receptacles and cafe and restaurant dining furniture for external and internal applications. Botton + Gardiner furniture can be found in shopping centres, council parklands and aged care facilities, as well as corporate breakout and meeting spaces. In hospitality, Botton + Gardiner products lend their distinctive character to five star hotels and restaurants designed by leading architects and interior designers.





CONTENTS

LOUNGES



Atomik
Modular Pod p6



Ava
Lounge p12



FGP Collaborative
Modular Seating p20



Forum
Lounge p26



Hub
Curved Lounge p30



Hub
Straight Lounge p30



Isobar
Mall Module p36



Isobar
Dining Module p38



Platform
Lounge p50



Vic
Lounge p58



Xofa
Lounge p62

ARMCHAIRS



Ava
Armchair p12



Brittany
Armchair p16



Jak
Chair p42



Julie
Armchair p46



Platform
Armchair p51



Tully
Mother's Tub Chair p56



Vic
Armchair p58



Xofa
Armchair p62

OTTOMANS



FGP Collaborative
Modular Seating p20



Hub
Ottoman p30



Isobar
Mall Ottoman p36



Pipe
Ottoman p48



Stratus
Ottoman p52



Xottoman
Ottoman p62

COORDINATES p64

FINISHES p67

POWER p81

FIXING + ASSEMBLY p87



Atomik

Modular Pod



Atomik is a flexible modular seating solution that easily fits into walkways or makes up mini mixed use pods with your choice of tables, planters and power. Choose how customers use your space; as a quick coffee stop or working lunch - all whilst charging a laptop or phone. Make Atomik as small or large as you like and use our huge array of finishes to tailor to your style. Check out some of our small pod suggestions or refer to our full Atomik catalogue for more detail.

FINISHES

Upholstery – custom fabric

Foam – high density, fire retardant foam with dacron

Internal frame – high moisture resistant board

Table / Planter body – powdercoated galvanised steel, see page 74 for standard colour ranges

Table / Planter top – Stratek 3D Laminate, Hardwood, Lightblocks Board, Engineered Stone, Corian or Compact Laminate, see page 67 for standard colour ranges

Legs – satin stainless steel with fixed glides

FABRIC

Select a fabric from the Baresque range, specify a custom fabric or supply your own.

Fabric required (based on one plain colour/ textured fabric, 137cm wide)

- O1 Rectangular Ottoman: 3.5mtrs

- BR2 1400mmL Backrest: 1.5mtrs

- ARM Armrest: 0.8mtrs

- O3 Small moon ottoman: 2mtrs

FEATURES

Easy to configure with 13 geometric shapes available, see Atomik catalogue for full range

Fully fixed upholstery is low maintenance and easy to repair or re-upholster through botton + gardiner with minimal down time

Power can be added to Tables or Planters to create charging stations for customers, see page 82-83 for options

Planter liners are marine grade stainless steel for direct planting (optional galvanised steel available for faux plants)

WARRANTY

2 years

INDICATIVE LEADTIME

6 weeks depending on project size

ASSEMBLY

Items delivered to site in modules. Some simple assembly required (by others) to connect modules using brackets already fitted to undersides of modules. See page 89 for details. Backrests and arms are pre-fitted to ottomans.



MALL SEATING CONFIGURATION IDEAS

See some of our suggested mall pods below.

Atomik is easy to configure with 13 geometric shapes available, see the Atomik catalogue for full range.

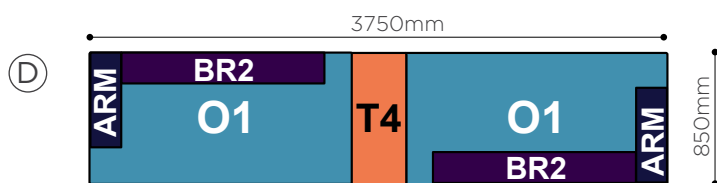
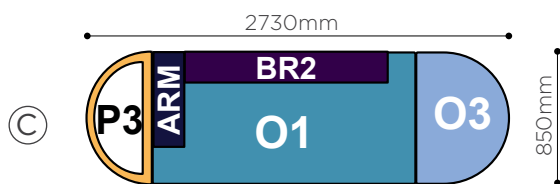
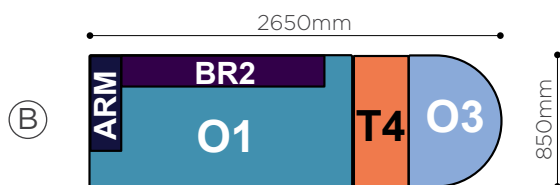
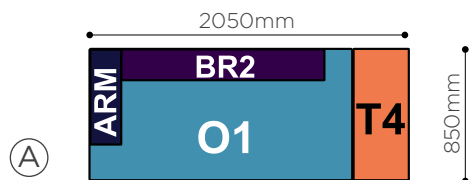

TRAVEL
THE TRAVEL PROFESSIONALS



Commonwealth Bank







Ava

Lounge



The Ava is a compact and comfortable sofa with a neat, tailored aesthetic. Great for spaces with a tight budget and restricted space. Also ideal if fixed seat upholstery is important for ease of cleaning or theft reduction. Ava is made to order locally in Sydney to your fabric specification inside a low lead time.

FINISHES

Upholstery – custom fabric
 Foam – high density, fire retardant foam with dacron
 Internal frame – solid timber with high moisture resistant board arms
 Legs – brushed stainless steel with fixed glides

FABRIC

Select a fabric from the Baresque range, specify a custom fabric or supply your own.

Fabric required (based on one plain colour/textured fabric, 137cm wide)

- Armchair: 3.4mtrs
- 2 Seater 1360mmL: 4.6mtrs
- 2.5 Seater 1770mmL: 5.2mtrs
- 3 Seater 1985mmL: 5.7mtrs

FEATURES

Create matching settings with the full range of sizes available
 Easy to move for cleaning or relocation
 Seat and backrest angles carefully considered for comfort
 Great compact shape for size restricted areas
 Fixed upholstery minimises maintenance and tidying

WARRANTY

2 years

INDICATIVE LEADTIME

6 weeks depending on project size

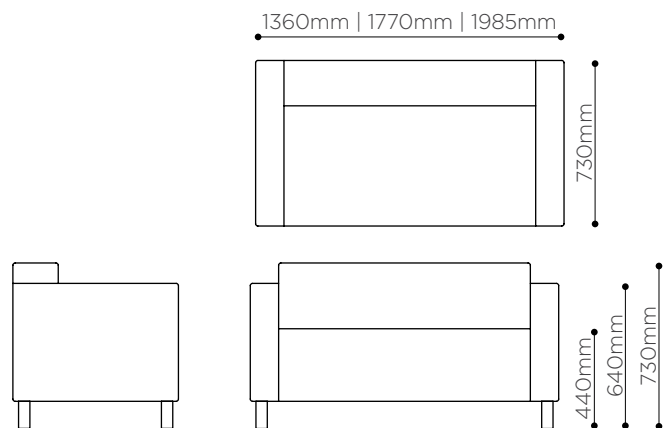
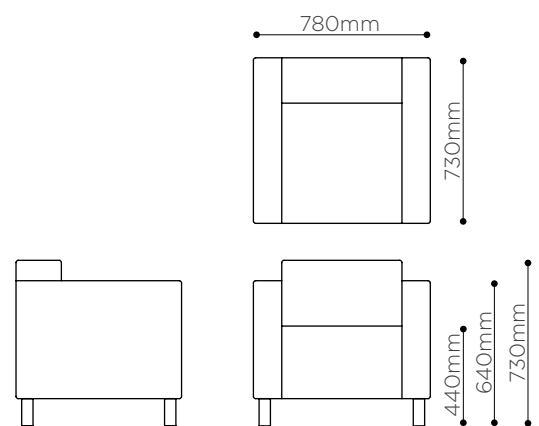

JONES







Brittany

Armchair



Brittany is a curved back wing chair excellent for that moment of privacy in busy commercial settings or in parents rooms as an infant feeding chair. Brittany has an elegant piped detail working effortlessly to show off contrasting fabrics. Use Brittany in mall pod seating, parents rooms, lobbies, workspaces and education spaces. With your choice of fabric, Brittany is made in Sydney to deliver a quick lead time.

FINISHES

- Upholstery – custom fabric
- Foam – high density, fire retardant foam with dacron
- Internal frame – solid timber
- Legs – tasmanian oak, natural finish

FABRIC

Select a fabric from the Baresque range, specify a custom fabric or supply your own. Fabric required 4.6mtrs (based on one plain colour/ textured fabric, 137cm wide)

FEATURES

- Create privacy without blocking sight lines
- Easy style to co-ordinate with both traditional and more modern settings
- Reversible seat cushion for cleaning and even wearing
- Nail in glides protect your floor and are easy to replace

WARRANTY

2 years

INDICATIVE LEADTIME

6 weeks depending on project size

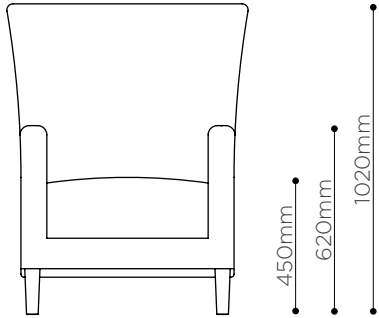
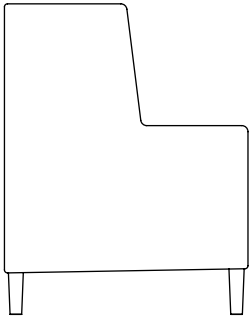
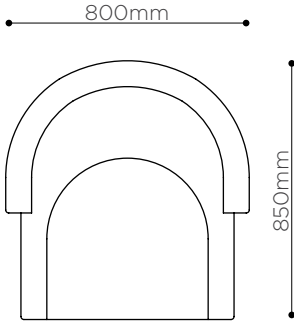







FGP Collaborative

Modular Seating



FGP Collaborative is unique, organic and strikingly contemporary in its appearance. Use straight or curved modules to create flexible seating with optional planters, backrests and laptop tables. FGP Collaborative is so visually light, it avoids interrupting tenancy visibility, is easy to clean beneath and its compact profile is ideal for narrow spaces. Outdoor suitable finishes are available for use on terraces, outdoor eating galleries or canteens. Suggested layouts for mall seating below or refer to the full FGP Collaborative catalogue for more information.

FINISHES

Upholstery – custom fabric

Foam – high density, fire retardant foam with dacron

Legs – satin clear anodised or powdercoated aluminium castings

End Table – Stratek 3D Laminate, Hardwood, Lightblocks Board, Engineered Stone, Corian or Compact Laminate

Laptop Table – steel satin polished or powdercoated

Laptop Table Top – Stratek 3D Laminate, Hardwood, Lightblocks Board, Engineered Stone, Corian or Compact Laminate

See page 67 for standard colour ranges

FABRIC

Select a fabric from the Baresque range, specify a custom fabric or supply your own.

Fabric required (based on one plain colour/ textured fabric, 137cm wide)

- Curved Bench module: 2mtrs
- Curved Seat module: 4mtrs
- Straight Bench module: 2mtrs
- Straight Seat module: 4mtrs

FEATURES

A huge variety of configurations can be created, see the FGP Collaborative catalogue for full details

The slender profile is elegant and visually light.

Optional Laptop or End Tables

Power can be added to In-Line Planters or End Tables to create charging stations, see pages 82-83 for GPO options

Suitable for outdoor use in appropriate finishes, see the FGP Collaborative catalogue for options

WARRANTY

2 years (5 years external grade finishes)

INDICATIVE LEADTIME

6 weeks depending on project size and stock availability

ASSEMBLY

Items delivered in modules to site. Some simple assembly is required (by others) to bolt modules together (hardware supplied)

FIXING

Placing loose is possible, but please note that for some configurations, a stability sled foot may be required.

For surface fixing (by others) see page 88 for details.

MALL SEATING CONFIGURATION IDEAS

Suggested layouts for mall seating below or see the FGP Collaborative catalogue for more information.

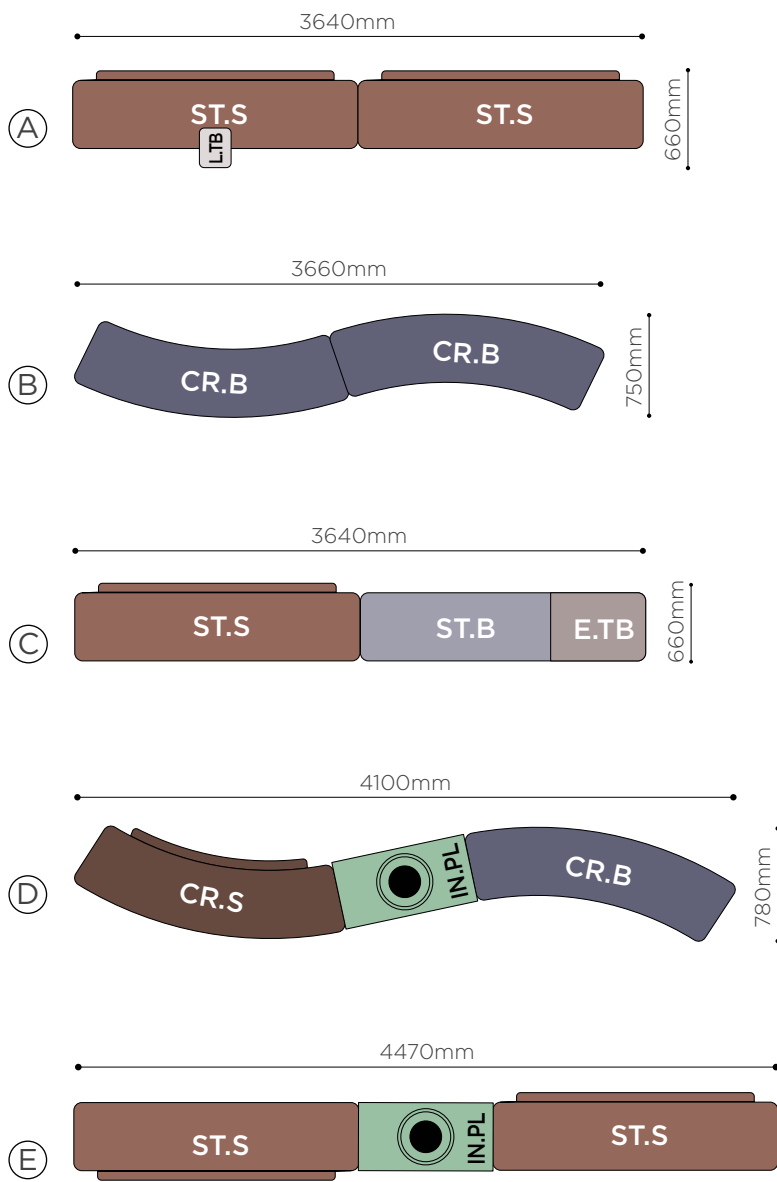









Forum

Lounge



Forum is one of our quintessential mall pieces. Ideal for high-traffic locations where risk of trolley impact is high, the boxy steel frame protects and reduces upholstery impact whilst giving Forum its industrial aesthetic. Optional armrests helps with ease of access for the elderly.

FINISHES

Upholstery – custom fabric

Foam – high density, fire retardant foam with dacron

Frame – steel satin polished or powdercoated, see page 74 for standard colour range

FABRIC

Select a fabric from the Baresque range, specify a custom fabric or supply your own.

Fabric required (based on one plain colour/ textured fabric, 137cm wide)

- 1800mm Seat: 4mtrs
- 2400mm Seat: 5mtrs
- 1800mm Back-to-back Seat: 5.5mtrs
- 2400mm Back-to-back Seat: 7.5mtrs

FEATURES

Fully fixed upholstery is low maintenance

Steel frame helps protect upholstery from trolley impact

Optional arms to help with ease of access for elderly clients

Fixed glides protect your flooring and are easy to replace

WARRANTY

2 years

INDICATIVE LEADTIME

6 weeks depending on project size

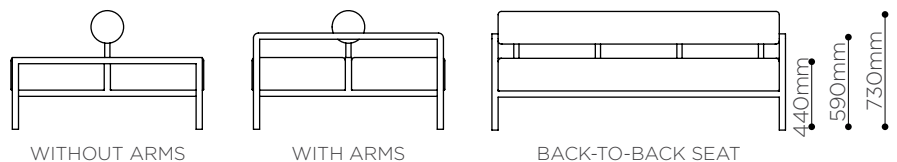
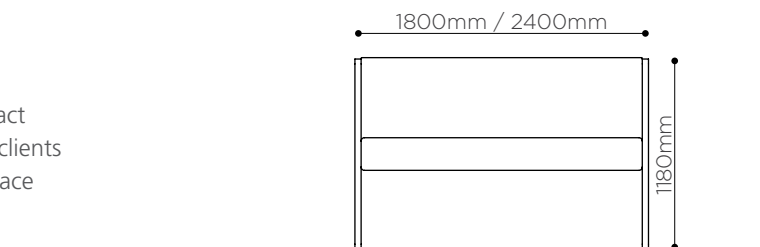
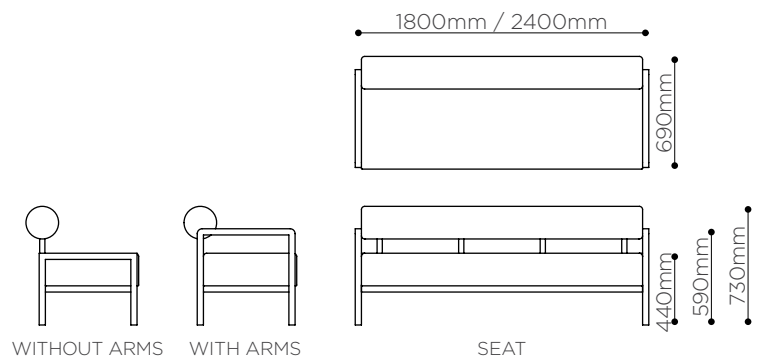







Hub

Lounge and Ottoman



The cornerstone piece of our Australian upholstered collection, Hub, delivers the classic pause point for shoppers, parents juggling children and people waiting for friends. Designed with high traffic commercial spaces in mind, Hub is durable and low maintenance with its simple profile making it easy to dress up in bold patterns or keep neutral. Enjoy Hub's new accessories and curved forms for extra versatility.

FINISHES

Upholstery – custom fabric

Foam – high density, fire retardant foam with dacron

Internal frame – high moisture resistant board

Frame – steel satin polished or powdercoated, see page 74 for standard colour ranges

Laptop Table – steel satin polished or powdercoated, see page 74 for standard colour range

Laptop Table Top – Stratek 3D Laminate, Hardwood, Lightblocks Board, Engineered Stone, Corian or Compact Laminate.

See page 67 for standard colour ranges

FABRIC

Select a fabric from the Baresque range, specify a custom fabric or supply your own.

Fabric required (based on one plain colour / textured fabric, 137cm wide)

Straight

- Ottoman 1800mmL: 2mtrs
- Ottoman 2400mmL: 2.5mtrs
- Seat 1800mmL: 3.5mtrs
- Seat 2400mmL: 4.5mtrs
- Back-to-back Seat 1800mmL: 6mtrs
- Back-to-back Seat 2400mmL: 7mtrs

Curved

- Curved Ottoman: 2.5mtrs
- Curved Convex Seat: 4mtrs
- Curved Concave Seat: 4mtrs
- Curved Back-to-back Seat: 7mtrs

FEATURES

Fully fixed upholstery is low maintenance

Steel frame helps protect upholstery from trolley impact

Optional power and laptop tables to help with flexibility of use, see page 82-83 for GPO options

Fixed glides protect your flooring and are easy to replace

Local manufacture allows for easy future re-upholstery, repair and serviceability through botton and gardiner

WARRANTY

2 years

INDICATIVE LEADTIME

6 weeks depending on project size



MODULES STRAIGHT

Straight modules are popularly used as free standing seating modules in corridors and entry areas. They look great in clusters with a bin and some planters. Straight modules are available in 2 lengths.

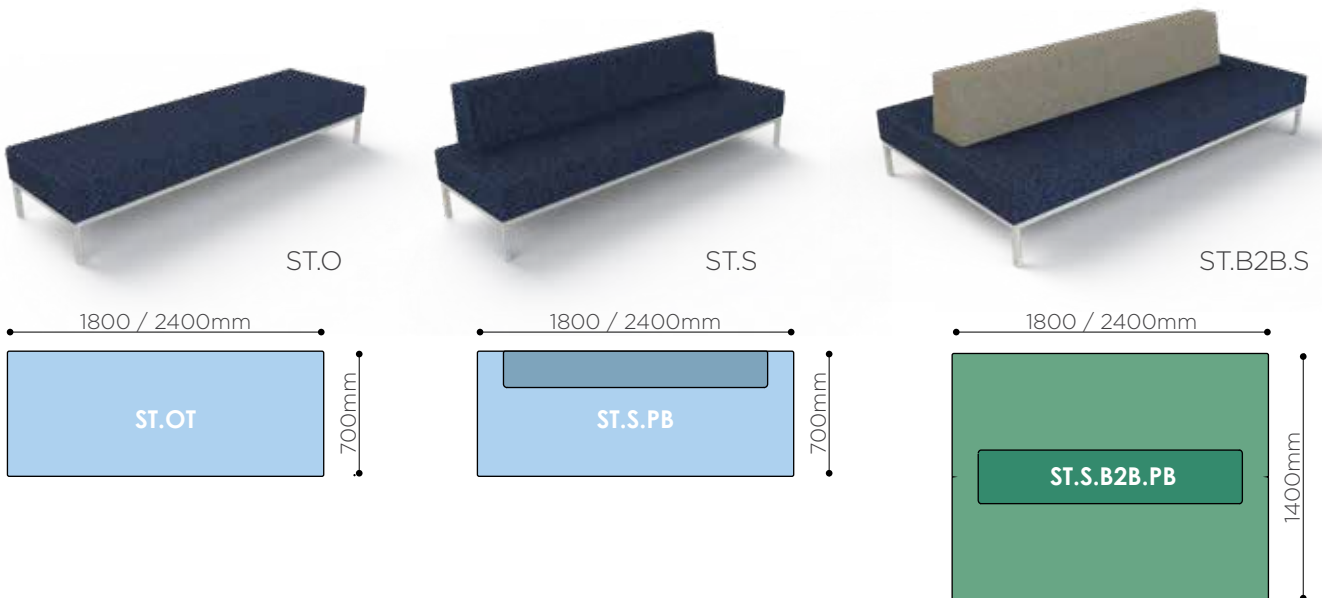

CURVED

Curved modules are commonly used butted together to form chains of snaking or curved seating. The backrest can run the whole length or be shorter and positioned to the centre, left or right. Curved modules have set radius and arc lengths as standard, but can be customised on request.





←
LIFTS

CODE
18

CURVED MODULES CONFIGURATION IDEAS

Suggestions for popular curved mall seating options below or we can assist you to create your own configurations.

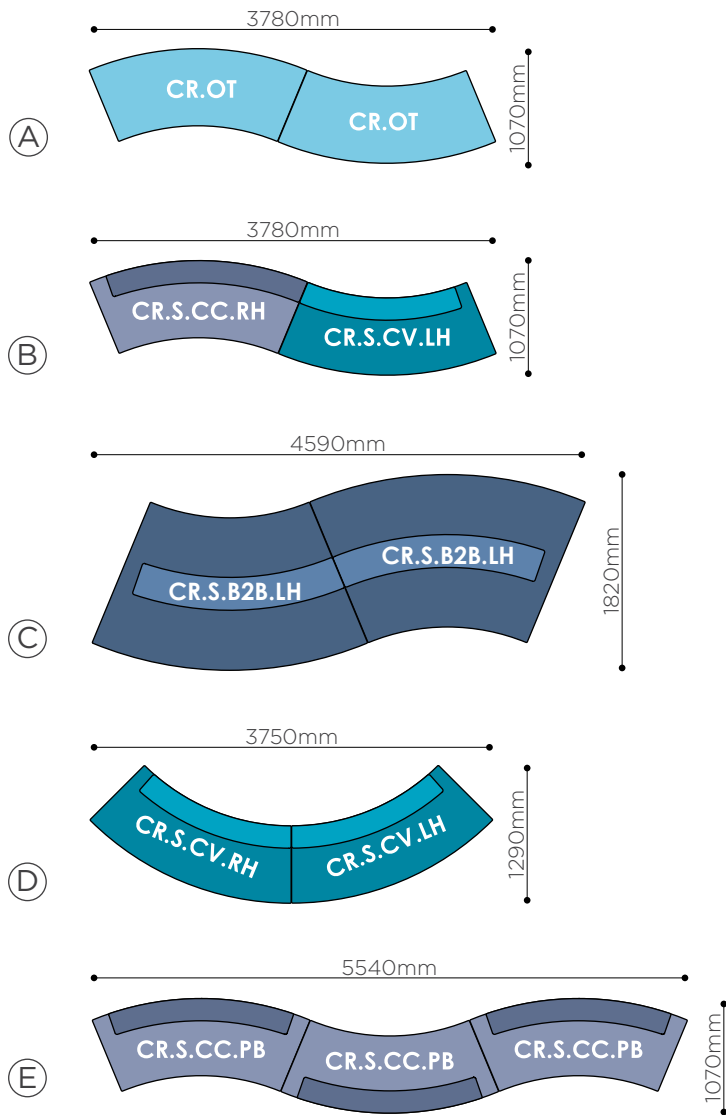



botton + gardiner - Upholstered



Isobar

Social Seating Mall Modules



Isobar is a flexible seating concept which fits easily in walkways. Isobar can be made as small or large as you like; use standalone modules or place together to create seating islands. We've created ideal mall modules for you below.

FINISHES

Upholstery – custom fabric

Frame – powdercoated steel, see page 74 for standard colour range

Armrest – Stratek 3D Laminate, Hardwood, Lightblocks Board on ply, or Compact Laminate.

See page 67 for standard colour ranges

Planter Liner – 316 stainless steel satin polished (real plants direct planted) or galvanised steel powdercoated (faux plants), see page 74 for standard colour range

FABRIC

Select a fabric from the Baresque range, specify a custom fabric or supply your own.

Fabric required (based on one plain colour/ textured fabric, 137cm wide)

- Mall Ottoman with arm: 3mtrs

- Mall Seat with planter: 5mtrs

FEATURES

Ability to integrate greenery without separate pots taking up floorspace

Fixed glides protect your flooring and are easy to replace

Local manufacture allows for easy future re-upholstery and repair

Suitable for outdoor use in appropriate finishes, see Isobar catalogue for information

Flexible customisation and huge array of configurations possible, chat to us for more info

WARRANTY

2 years

INDICATIVE LEADTIME

6 weeks depending on project size

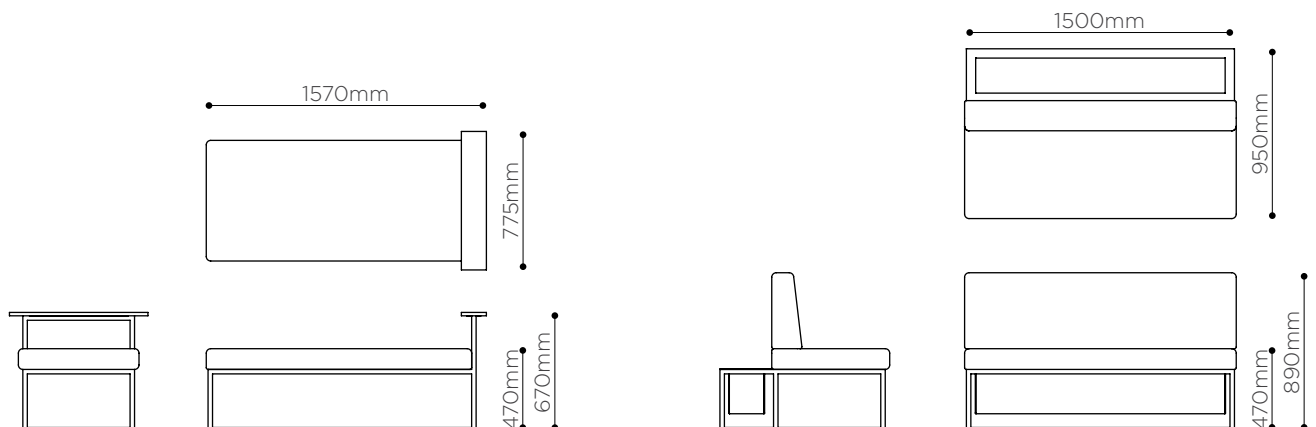



Isobar

Social Seating Dining Module



Isobar is a flexible seating concept which fits easily in walkways and can make mini mixed use pods. Choose how customers use your space and furniture; as a quick pause point or a working lunch over a laptop. Place together outside food tenancies to easily expand dining areas. Refer to the full Isobar catalogue for how to easily design your own tailored solution.

FINISHES

Upholstery – custom fabric

Foam – high density, fire retardant foam with dacron

Frame – powdercoated steel, see page 74 for standard colour range

Back panel – Stratek 3D Laminate (horizontal grain direction), Hardwood, Lightblocks Board with 12mm ply core, or Compact Laminate.

Table top inset – Stratek 3D Laminate, Hardwood, Lightblocks Board on ply, or Compact Laminate.

See page 67 for standard colour ranges

FABRIC

Select a fabric from the Baresque range, specify a custom fabric or supply your own.

Fabric required (based on one plain colour/ textured fabric, 137cm wide)

- Mall Dining Module: 5mtrs

FEATURES

Use as a division of space without blocking sight lines

Feature piece with flexible use

Fixed glides protect your flooring and are easy to replace

Suitable for outdoor use in appropriate finishes, see Isobar catalogue for information

WARRANTY

2 years

INDICATIVE LEADTIME

6 weeks depending on project size

MOUNTING

Items loose or surface fixed (by others) via holes in the frame (anchors not included)

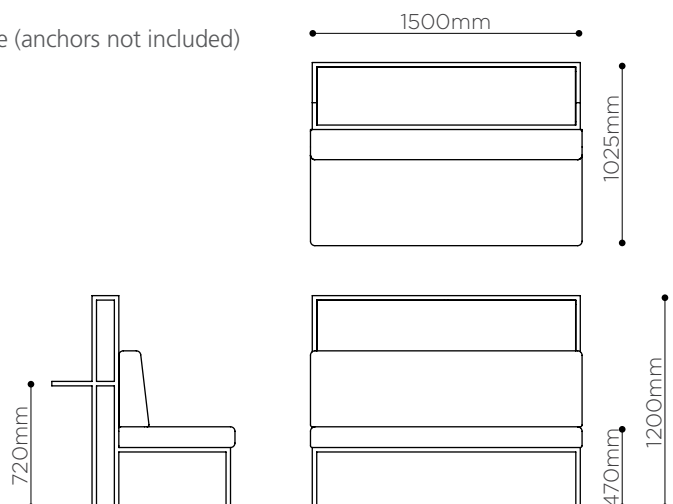







Jak

Armchair



Jak is an excellent compact armchair for when space is tight but comfort is equally important. Ideal for aged care, parents rooms and workspaces, Jak's solid hardwood legs bring a classic elegance to a commercial environment. With your choice of fabric, Jak is made in Sydney to deliver a quick lead time.

FINISHES

Upholstery – custom fabric
 Foam – high density, fire retardant foam with dacron
 Internal frame – solid timber
 Legs – tasmanian oak, natural finish

FABRIC

Select a fabric from the Baresque range, specify a custom fabric or supply your own.
 Fabric required 1.9mtrs (based on one plain colour/ textured fabric, 137cm wide)

FEATURES

Easy style to co-ordinate with both traditional and more modern interiors
 Fixed upholstery for easy maintenance and wipe down
 Nail in glides protect your floor and are easy to replace

WARRANTY

2 years

INDICATIVE LEADTIME

6 weeks depending on project size

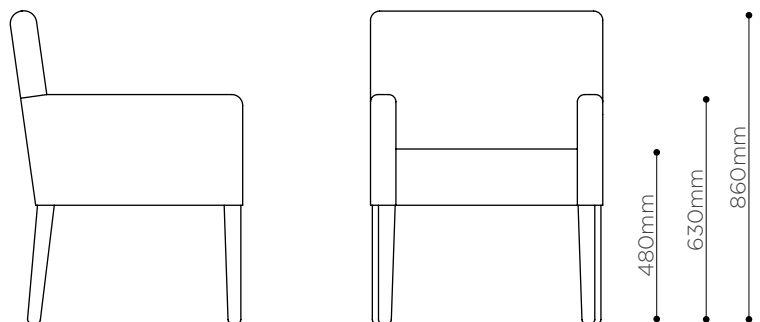
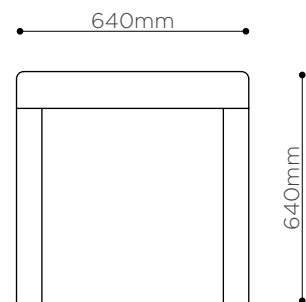







Julie

Armchair



With its elegant lines and gently curved arms the Julie Armchair is a must-have classic. The comfortable and supportive high back and lower arms ensures Julie is perfect for use in any environment, especially as an infant feeding chair in parents rooms. your choice of fabric, Julie is made in Sydney to deliver a quick lead time.

FINISHES

Upholstery – custom fabric
 Foam – high density, fire retardant foam with dacron
 Internal frame – solid timber
 Legs – tasmanian oak, natural finish

FABRIC

Select a fabric from the Baresque range, specify a custom fabric or supply your own.
 Fabric required 4.8mtrs (based on one plain colour / textured fabric, 137cm wide)

FEATURES

Classic comfort in a more contemporary look
 Matching sofa available
 Reversible seat cushion for cleaning and even wearing
 Nail in glides protect your floor and are easy to replace
 Piping detail looks great in contrasting colours for extra detailing

WARRANTY

2 years

INDICATIVE LEADTIME

6 weeks depending on project size

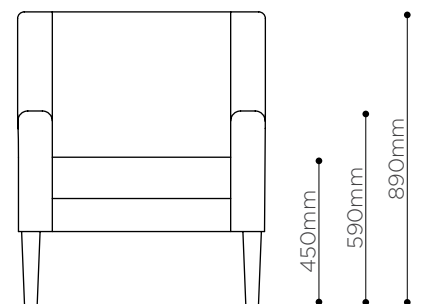
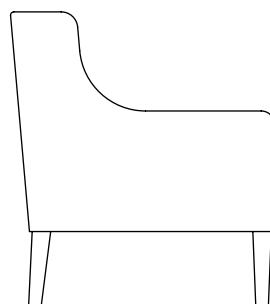
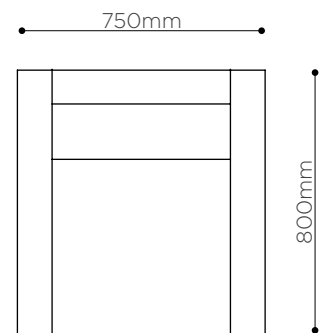





Pipe is a simple cylinder ottoman with a lovely piped detailing around the top rim. Great for extra seating in pod settings with lounges, coffee or laptop tables and armchairs, Pipe is easily mobile for agile workspaces or educational study hubs. With your choice of fabric, Pipe is made in Sydney to deliver a quick lead time.

FINISHES

Upholstery – custom fabric
 Foam – high density, fire retardant foam with dacron
 Internal frame – high moisture resistant board

FABRIC

Select a fabric from the Baresque range, specify a custom fabric or supply your own.
 Fabric required (based on one plain colour / textured fabric, 137cm wide)
 - Small Ottoman: 1.3mtrs
 - Small Ottoman contrast Piping: 0.5mtrs
 - Large Ottoman: 2.6mtrs
 - Large Ottoman contrast Piping: 0.5mtrs

FEATURES

Various sizes for a single or multiple seat ottoman
 Local manufacture allows for easy future re-upholstery and repair through botton + gardiner
 Nail in glides protect your floor and are easy to replace
 Piping detail looks great in contrasting colours for extra detailing

WARRANTY

2 years

INDICATIVE LEADTIME

4-6 weeks depending on project size

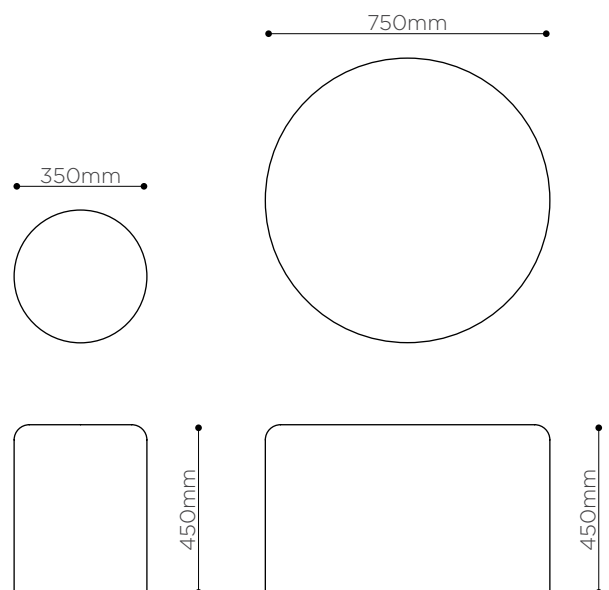



Platform

Lounge



Platform is your quintessential commercial sofa style with simplistic, square form arms and fixed back upholstery. Well priced, easy to wipe over and maintain, Platform is easy to move for cleaning, not to mention comfortable for a wide demographic of customers. With your choice of fabric, Platform is made in Sydney to deliver a quick lead time.

FINISHES

Upholstery – custom fabric
 Foam – high density, fire retardant foam with dacron
 Internal frame – solid timber
 Legs – brushed stainless steel

FABRIC

Select a fabric from the Baresque range, specify a custom fabric or supply your own.

Fabric required (based on one plain colour/textured fabric, 137cm wide)

- Armchair: 4mtrs
- 2 Seater: 5.5mtrs
- 2.5 Seater: 7mtrs
- 3 Seater: 7.5mtrs

FEATURES

Create matching settings with the full range of sizes available
 Easy to move for cleaning or relocation
 Seat and backrest angles carefully considered for comfort
 Great compact shape for size restricted areas
 Fixed upholstery for low maintenance and easy wipe down

WARRANTY

2 years

INDICATIVE LEADTIME

6 weeks depending on project size

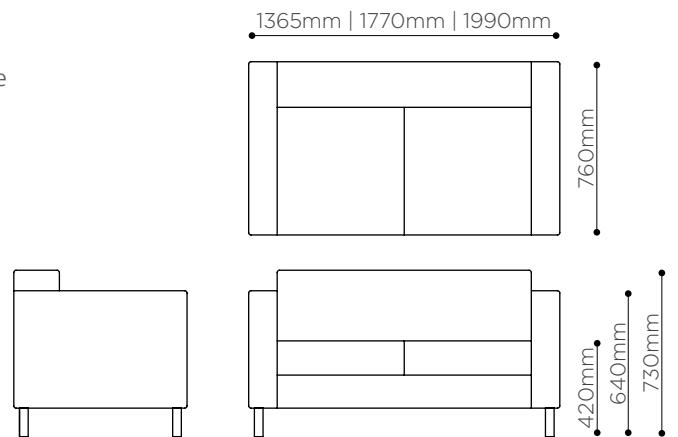
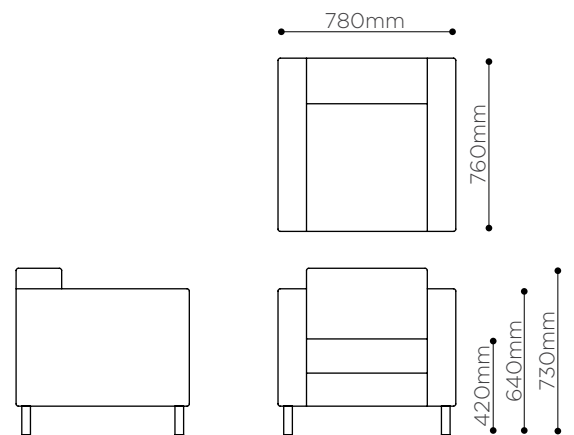



Stratus

ottoman



The Stratus ottoman is a classic, minimalistic piece ideal for pod settings or entry points in shopping centres, malls, lobbies and workspaces. With an array of Stratek colours available, the plinth base can take on the aesthetic of hardwood, marble, concrete or corten metal depending on your interior styling.

FINISHES

Upholstery – custom fabric

Foam – high density, fire retardant foam with dacron

Internal frame – steel

Frame cladding – Stratek 3D Laminate on high moisture resistant substrate, see page 70 for standard colour ranges

FABRIC

Select a fabric from the Baresque range, specify a custom fabric or supply your own.

Fabric required (based on one plain colour/textured fabric, 137cm wide)

- Full length cushion: 2.2mtrs

- Partial length cushion: 2mtrs

FEATURES

Timber, concrete or stone looks in a wide range of colours on the plinth at an affordable pricepoint

Stratek's ability to wrap around the frame delivers increased durability over standard high pressure laminate application

Internal steel frame ensures commercial suitability whilst the cushion ensures comfort

The cushion is available as a full or a partial 3/4 length so the plinth can be used as an end table

Power can be added to the Stratus to create charging points for customers, see page 82-83 for GPO options

Glides protect your floor and are easy to replace

WARRANTY

2 years

INDICATIVE LEADTIME

6 weeks using a stocked Stratek colour, depending on project size

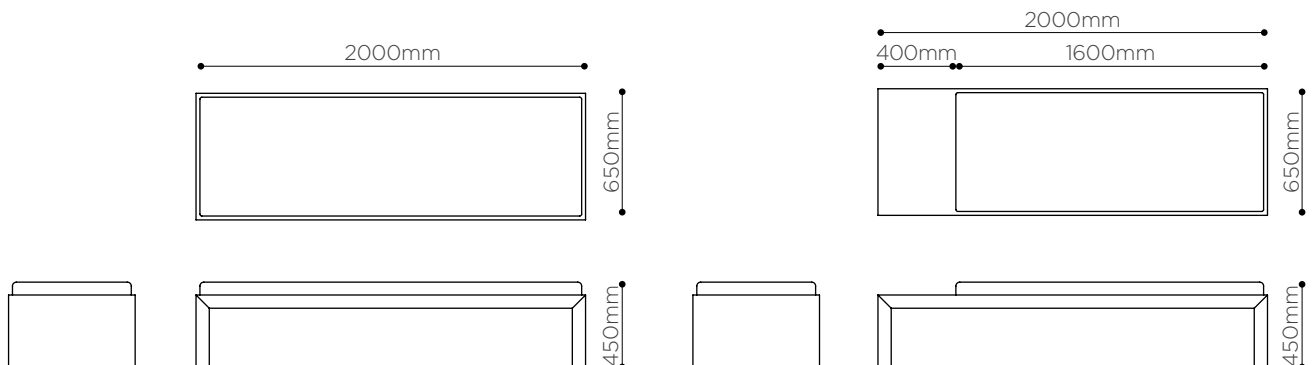







Tully

Mother's tub chair



The Tully Mother's Tub chair is a timeless tub chair, easy to blend into classic or contemporary settings and ideally suited as an infant feeding chair for parent rooms. With its timber legs, the chair can be matched to a solid timber side table for casual cafe, club or mall settings.

FINISHES

Upholstery – custom fabric
 Foam – high density, fire retardant foam with dacron
 Internal frame – solid timber
 Legs – tasmanian oak, natural finish

FABRIC

Select a fabric from the Baresque range, specify a custom fabric or supply your own.
 Fabric required 2.4mtrs (based on one plain colour/textured fabric, 137cm wide)

FEATURES

Lovely curved profile and piping details
 Great compact shape for size restricted areas
 Comfortable for a wide demographic of customers
 Fixed upholstery for low maintenance and easy wipe down

WARRANTY

2 years

INDICATIVE LEADTIME

6 weeks depending on project size

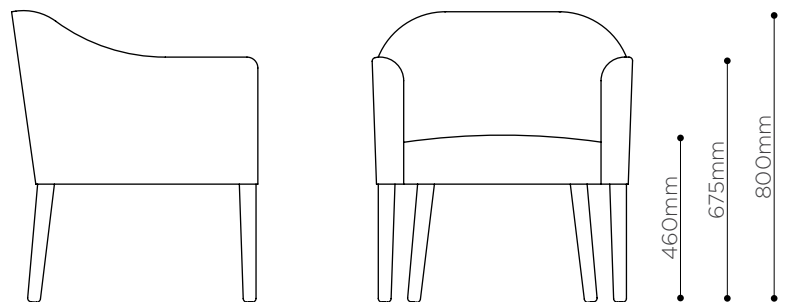
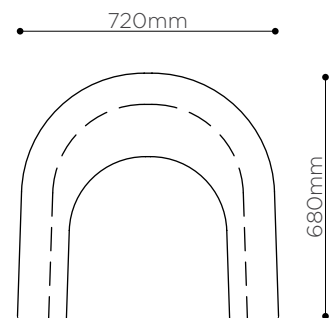





The Vic Lounge is a contemporary take on an angled 70's classic. The "wing" detailing on the ends adds visual interest and a sense of fun to an elegant commercial sofa whilst the timber legs add a touch of warmth in an office, education or lobby environment. With your choice of fabric, Vic is made in Sydney to deliver a quick lead time.

FINISHES

Upholstery – custom fabric
 Foam – high density, fire retardant foam with dacron
 Internal frame – solid timber
 Legs – New Zealand beech timber, natural finish

FABRIC

Select a fabric from the Baresque range, specify a custom fabric or supply your own.

Fabric required (based on one plain colour/textured fabric, 137cm wide)

- Armchair: 3.5mtrs
- 2 Seater: 4.6mtrs
- 2.5 Seater: 5.1mtrs
- 3 Seater: 5.8mtrs

FEATURES

Create matching settings with the full range of sizes available
 Nail in glides protect floors and are easy to replace
 Fixed upholstery for low maintenance and easy wipe down

WARRANTY

2 years

INDICATIVE LEADTIME

6 weeks depending on project size

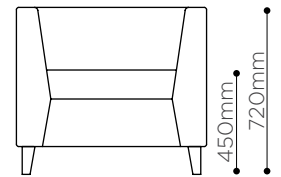
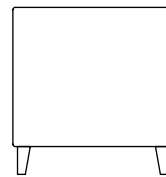
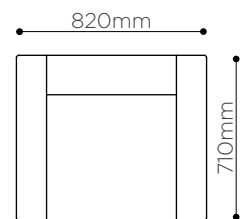

1340mm | 1620mm | 1900mm

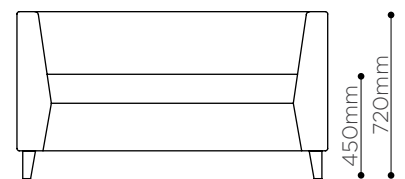
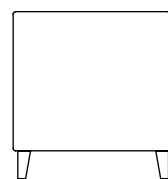
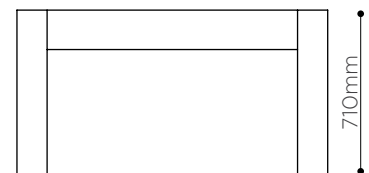







Xofa + Xottoman

Lounge and Ottoman



The unique Xofa brings to mind rustic wooden pallets, upcycled barn doors and recycled shipping crates. Ideal for both internal and external use in universities, education, bars, cafes, hospitality and rooftops. The durable and stoic framing impresses clients with longevity and groundedness and is a key design and structural feature, using responsibly sourced Hardwood or re-claimed wood composite DuraSlat cladding.

FINISHES

Upholstery – custom fabric

Foam – high density, fire retardant foam with dacron

Frame – Hardwood or DuraSlat, see pages 72-73 for standard colour ranges

FABRIC

Select a fabric from the Baresque range, specify a custom fabric or supply your own.

Fabric required (based on one plain colour/ textured fabric, 137cm wide)

- Xofa armchair: 3mtrs
- Xofa lounge: 4mtrs
- Xottoman ottoman 1900mmL: 3mtrs
- Xottoman ottoman 2200mmL: 4.5mtrs

FEATURES

Monolithic frame cladding is a key design feature

Suitable for outdoor use in appropriate finishes

Loose upholstery allows for easy removal and storage inside

DuraSlat is a low maintenance finish which unlike Hardwood does not require oiling

WARRANTY

2 years

INDICATIVE LEADTIME

6 weeks depending on project size

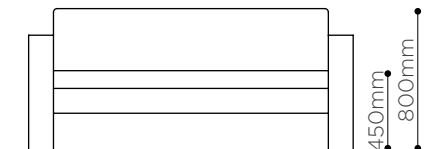
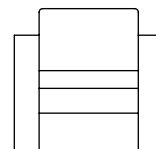
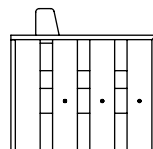
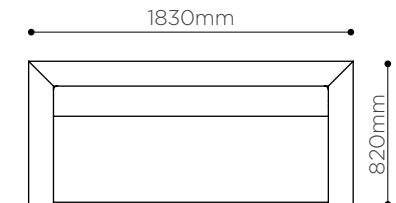
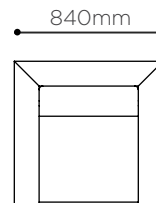
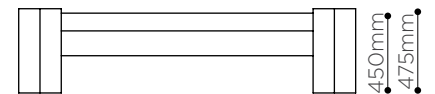
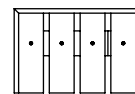
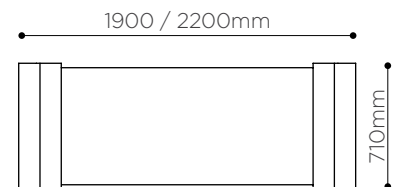



COORDINATES

Botton + Gardiner has a large range of coordinating pieces to complete your settings. Add bins and planters to bring greenery into your walkways, side tables for parent room convenience or coffee and laptop tables to pods for pause points to maximise your Wi-Fi service. Be inspired by our selection of low lead time items below or visit our website for our full range.



Cottesloe bin



Manly bin



Bronte bin



Boxwood bin



Botanist



Yin



Gnarly



Fair Dinkum



Geo



Hanzo



Bronte

FINISHES



ENGINEERED STONE

Engineered for modern living, our stone combines the beauty and prestige of natural stone with the hard-wearing qualities of quartz. These luxurious surfaces offer high performance with low maintenance and no need for sealing or waxing. Stone surfaces are manufactured with a minimum of 93% quartz which makes the surface highly durable.



ARCADIA



MARENGO



NAXOS



NOMBRE



ATHENA



NERO



CENIZA

CARE + MAINTENANCE

To keep your Engineered Stone clean, simply wipe with a soft cloth and a pH neutral household liquid detergent. Avoid exposure to products with high pH levels / solvents. If your Engineered Stone comes into contact with such products, rinse immediately to neutralise the effect, and then follow usual cleaning procedure.

CORIAN®

Corian® is an elegant decorative material that allows for seamless cladding of surfaces. This hardwearing material stands up well to daily wear and tear and resists most of the impacts, nicks and cuts that occur in heavy traffic areas. Corian® is a refinisable material making it ideal for busy commercial applications.

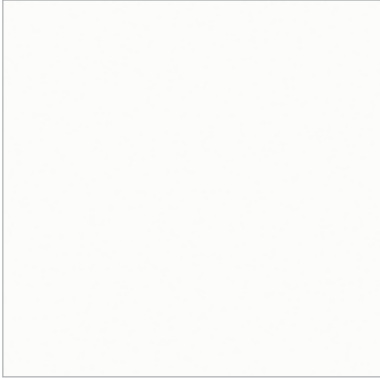

GLACIER WHITE

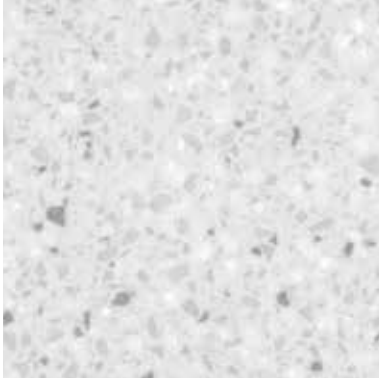

SILVER BIRCH



DOVE



DEEP NIGHT SKY



CLAY

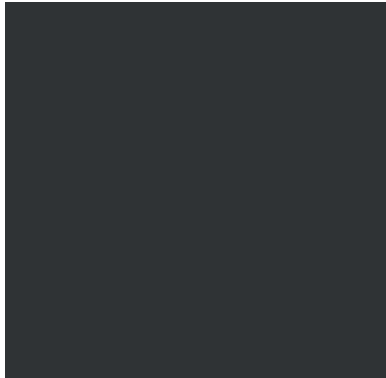

DEEP TITANIUM

CARE + MAINTENANCE

Generally, a damp microfiber cloth used with a standard household kitchen spray should remove most stains.

For most residues, all you need to clean your Corian® is warm soapy water or ammonia-based household cleaner. DO NOT use window cleaners as they can leave a waxy build-up that dulls the surface. Always clean using a circular motion.

If water is left to dry on the surface, film will build up dulling the surface making the finish appear blotchy and uneven. To prevent film build-up, try to wipe completely dry immediately after spills and cleaning.



STRATEK 3D Laminate

Stratek 3D laminates provide a high level of durability than standard thermofolios. With added impact, marring and abrasion resistance as well as improved stain resistance, they are excellent for use in commercial environments. The special ability to vacuum form Stratek gives it beautiful profiled edges which eliminates the need for traditional laminate edge treatments and continues the finish grain for a more realistic look.

PLAINS

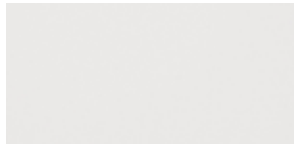

CAMP WHITE



FASHION GREY



MATTE BLACK



MATTE CADET



MATTE FOSSIL



MATTE GREIGE



MATTE MALACHITE



SLATE GREY

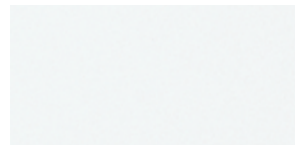

WHITE 949

STONE



CARRARA

WOOD GRAINS



AGED BROWN OAK



RIFT OAK NATURAL



MARKET OAK GREY



MARKET OAK
WHITWASHED



SMOKEHOUSE OAK



PROVIDENCE SABLE



PROVIDENCE KHAKI

METALLICS



JAZZ SILK



CONCRETE



CORTEN



OXIDISED PEWTER

CARE + MAINTENANCE

CLEANING: Wipe over with a clean, soft cloth dampened with a mild solution of liquid detergent and warm water. Repeat using only clean water, then dry with a lint free cloth. Avoid using wax polishes, solvents or concentrated abrasives. For more difficult stains, dampen a soft white cloth with a solution of household bleach and water at 1:9 ratio. Rub gently. Rinse with a water dampened cloth to remove bleach concentrate. Always test in an inconspicuous area first.

COMPACT LAMINATE [Internal Use]

Compact Laminate with Protect+™ anti-microbial surface performance is strong, durable and moisture resistant, making it suitable for a wide variety of uses. This versatile material requires no additional finish.

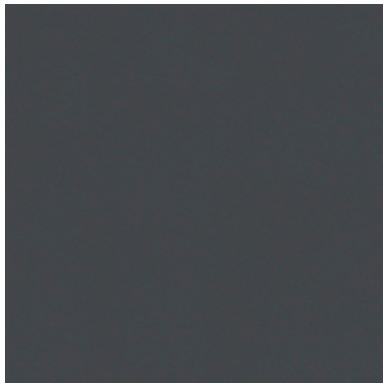

CHARCOAL

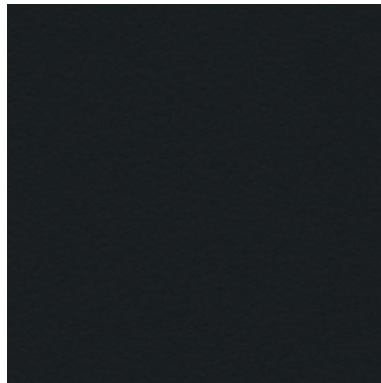

BLACK



BLACKENED LINEWOOD



LICORICE LINEA



ALASKAN



JERICO



SUBLIME TEAK

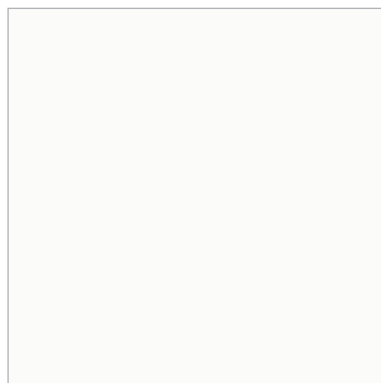

WHITE



SEASONED OAK

CARE + MAINTENANCE

For general care and maintenance, simply wipe away most spills or marks with a damp microfibre cloth, or use an all purpose cleaner such as Windex spray cleaner or Ajax Spray n Wipe. Rubbing gently with a clean, dry cloth brings back the brightness of laminates. DO NOT use abrasive or polishing materials.

AUSTRALIAN HARDWOOD

Our hardwoods are locally sourced from sustainably managed Australian regrowth forests. We select timber species that offer a grain structure and density that is ideally suited to a long life in the harsh public environment. In exterior applications the natural beauty of the timber is further enhanced and protected with three coats of exterior grade oil, pigmented for high UV resistance.



LACQUERED VIC ASH
[INTERNAL USE ONLY]



OILED BLACKBUTT



OILED SPOTTED GUM



OILED MIXED RED



EBONY OILED MIXED RED



CLEAR OILED MIXED RED

CARE + MAINTENANCE

Wipe down regularly with fresh water and a non-abrasive cloth.

For ongoing maintenance of oiled timbers, lightly sand rough areas of timber and brush on one coat of Sikkens Cetol HLS in the correct colour every 6 months or as required.

DURASLAT™

Duraslat™ is a composite material made from reclaimed hardwood fibres and recycled plastic to look and feel like timber but requiring no finish or maintenance. The unique properties of DuraSlat mean it won't warp or splinter whilst still being soft to the touch. UV and chemical resistance makes it ideal for the outdoor public environment. Guaranteed by the manufacturer for 10 years.

GRAIN

BATTEN PROFILE



GRAVEL PATH



LAVA ROCK



TIKI TORCH

BRUSHED

BATTEN PROFILE



JARRAH



SAHARA



BLACKBEAN



SILVERGUM

CARE + MAINTENANCE - **GRAIN**

For best results use a cleaner that contains any of the following as an active ingredient for general cleaning and follow the manufacturer's instruction for use:

- Phosphoric Acid
- Oxalic Acid
- Hydrochloric Acid
- Sodium Hypochlorite

Power washing will enhance results; 1500psi is the recommended maximum for DuraSlat. A fan tip nozzle should be used along with the proper cleaning product. Spray in the direction of the brush/grain pattern. Use caution not to damage the material and always take the proper safety precautions when operating a power washer.

CARE + MAINTENANCE - **BRUSHED**

As per Duraslat Grain but with specific maintenance:

The "brushed" (lighter side) finish provides a more textured "timber-like" finish and does not easily show scuffs and scratches. Brushed DuraSlat is not recommended for shaded areas as the sun and rain helps to clean the battens of any food based stains. The brushed finish can be wire-brushed or sanded with coarse sandpaper to remove scratches. The area you brush will quickly fade out and hide your repair.

POWDERCOATS - BOTTON + GARDINER

Powdercoating gives a uniform, durable, high quality and attractive finish that is low in VOCs. As well as being better for the environment, powdercoated surfaces are more resistant to chipping, scratching, fading and wearing than its alternatives. This cost-effective finish has great UV resistance and durability in the elements.

Custom colours can be specified from Interpon, Dulux or Oxytech locally available colour ranges. Custom colours will incur an additional set-up fee. Specialty powdercoats (i.e. ripple, metallics, pearl etc.) to be quoted upon selection as additional set-up charges may apply. Minimum quantity fees apply for powdercoating small orders in both custom and standard colours.

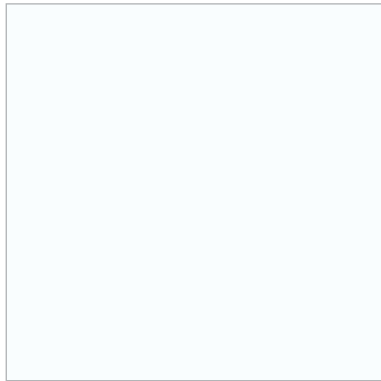

PEARL WHITE GLOSS



WHITE SATIN



BLACK SATIN



CHARCOAL SATIN

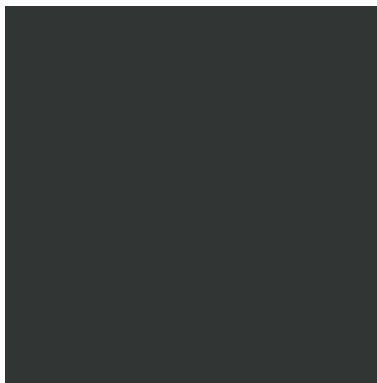

BLACK MATT



PALLADIUM SILVER

CARE + MAINTENANCE

1. Carefully remove any loose surface deposits with a wet sponge.
2. Use a soft (non abrasive) cloth or brush and a diluted solution of mild detergent and water (DO NOT use solvents) to remove dust, salt and other deposits.
3. Ensure surfaces are thoroughly rinsed with clean fresh water after cleaning to remove all residues.

POLYETHYLENE HANZO POT

Polyethylene is UV stable, light and durable. It is also incredibly versatile and one of the most widely used plastics in the world. Made in Australia this item can be completely recycled at the end of its life, available in all of the colours of the rainbow plus more.



CARE + MAINTENANCE

Use warm water, mild detergent, and a soft sponge or chamois to clean

LIGHTBLOCKS BOARD

Lightblocks Board is a fully refinishable, finger print proof resin with a soft touch. It has a matt finish and is bleach cleanable. Suitable for indoor applications only. Lightblocks Board is also available with Seraphic Digital Print. See next page for details.



CARE + MAINTENANCE

- Use warm water, mild detergent, and a soft sponge, cloth, or chamois to clean Lightblocks
- Surface contamination may be cleaned using kerosene, hexane, or aliphatic naphtha, or any acrylic cleaner, such as Novus. Always follow manufacturer's recommended use and safety procedures
- DO NOT use glass cleaning products, acetone, gasoline, benzene, lacquer thinner, chlorinated solvents, gritty abrasive scouring compounds, or alkaline cleaners to clean Lightblocks as damage to the sheet will occur
- Remove any oily residue left behind from solvent cleaning with detergent and water
- Do not use squeegee, scraper, or synthetic rags that may scratch Lightblocks
- When cleaning, never scrub Lightblocks. Gently wipe surface with a soft scratch free cloth

REFINISHING

- Light refinishing - if there is only a light scratch, refinishing can be achieved by using rubbing the area in a random circular motion with a fine steel scouring pad (Scotch-brite). Test in an inconspicuous area before attempting a main area on the job.

SERAPHIC HIGH PERFORMANCE DIGITAL PRINT

AVAILABLE ON LIGHTBLOCKS BOARD AND ZINTRAS® ACOUSTIC PANEL

Perfect for horizontal and vertical surfaces, take your project to the next level with Seraphic High Performance Digital Print. If you are after something a bit different, the flexibility and virtually limitless design options available with Seraphic Digital Print makes the world your oyster in terms of what can be achieved. Available on Lightblocks Board with no need to worry about the print as it is protected by our finger proof, soft touch, matt resin and also on our Zintra® Acoustic Panel, if acoustic properties and pinnability are required.



WOODY ARBOUR

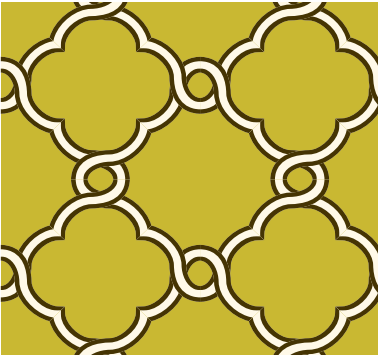

MOROCCASAIC

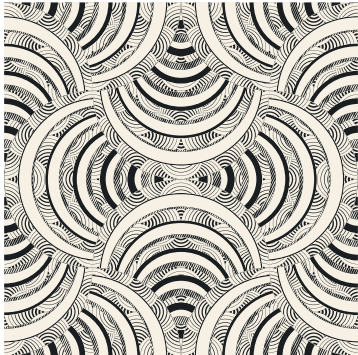

CLEOPATRA CROWNED



CHEVRON RIFF



URBAN HARMONY



CLIMBING CAMELIAS



RIPPLES IN THE CALM



IMPERIAL MARRAKECH

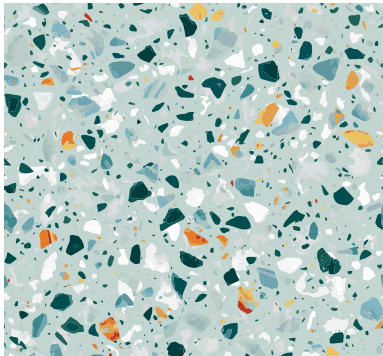

SHATTERED DREAMS

Digital Print designs shown are just a taste of what is available. Create your own design or contact botton + gardiner to discuss your design requirements.

For additional technical information please search for Seraphic at baresque.com.au

UPHOLSTERY FABRICS

Our sister company Baresque offers a wide range of well priced, high performance fabrics including Crypton, commercial and vinyl upholsteries.

Check out these swatches for just a few ideas, or call Baresque on 1300 306 399 to find out more.

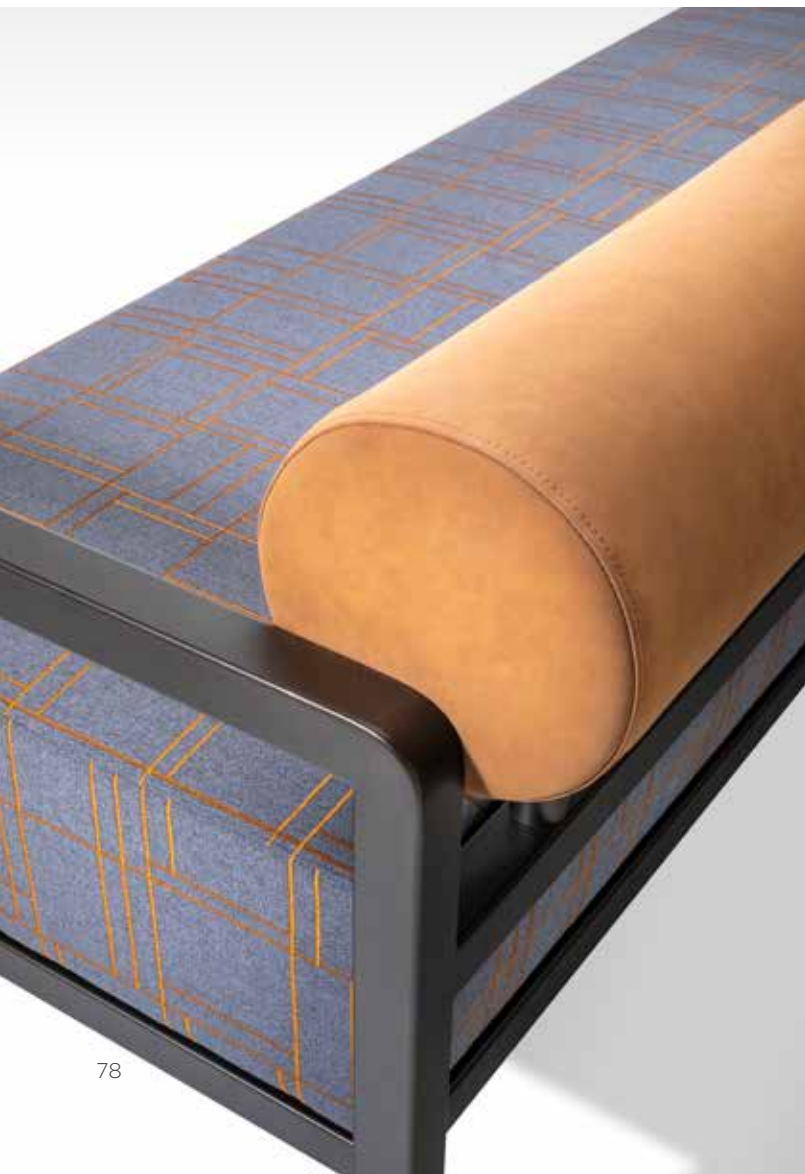

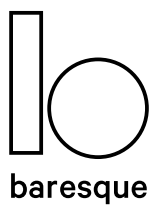
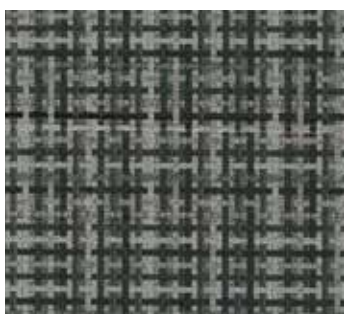
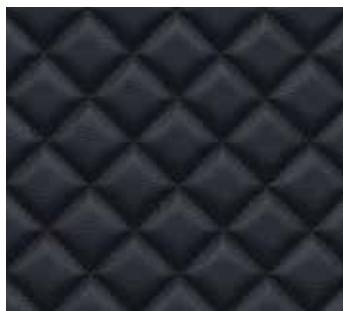
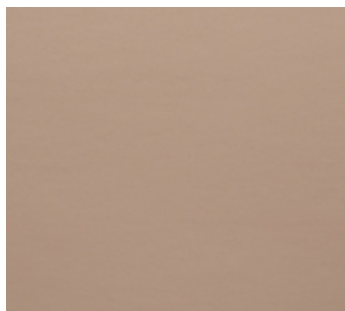

baresque

1300 306 399

baresque.com.au

info@baresque.com.au

POWER + ACCESSORIES



Pluto GPO

Horizontal surfaces



Pluto satisfies the demand for power and data connectivity in informal spaces. Perfectly suited to breakout areas, smaller meeting rooms and coffee tables, Pluto makes sharing power a pleasure. Studies show that people work far more effectively in small groups and indeed new ideas come from people working in pairs. With 3 outlet positions, Pluto is perfect for a small team to power/charge their devices using conventional mains plugs.

FINISHES

Fascia colour options: white or black

FEATURES

Configure the 3 outlet points as below:

- A. 3 x 5A twin USB fast chargers
- B. 2 x 5A twin USB fast chargers and 1 x Australian GPO plug
- C. 3 x Australian GPO plugs

Twin USB outlets certified to: AS/NZS 60950

GPO certified to: AS/NZS 3112

WARRANTY

1 year

ASSEMBLY

GPO is fitted to your Atomik module by Botton and Gardiner. Connection to the mains by a certified electrician (not included) via a 2000mm lead with standard 10A 3-pin plug or 800mm lead with Elsafe 'J-coupler'

For additional technical information please contact Botton and Gardiner via info@bottonandgardiner.com.au

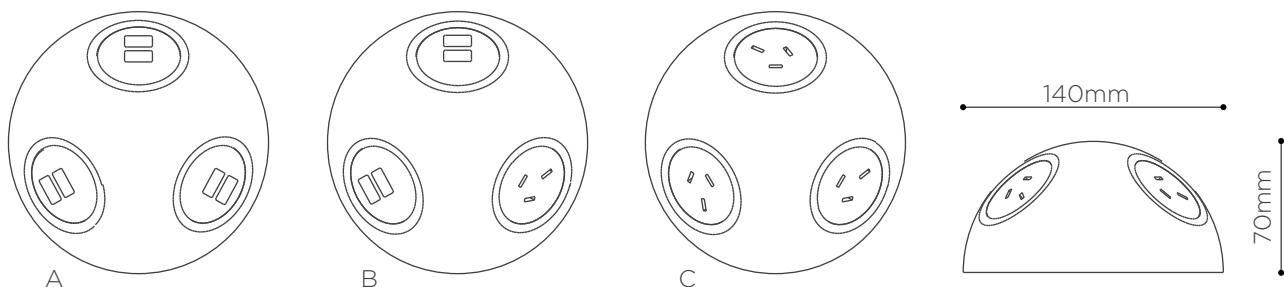

Pixel GPO

Vertical surfaces



Pixel enables time-short customers to charge their laptop, mobile phone and tablet at the same time! This makes it perfect for drop in areas, airports, shopping centres, universities & hotels. Pixel fits almost flush for a discrete finish and it's unique sweeping organic curves ensure protection against liquid ingress.

FINISHES

Fascia colour options: white or black

Perimeter ring colour: silver

FEATURES

Configured with 1x Australian GPO plug and 1x 5A twin USB fast charger

Twin USB outlets certified to: AS/NZS 60950

GPO certified to: AS/NZS 3112

WARRANTY

1 year

ASSEMBLY

GPO is fitted to your Atomik module by Botton and Gardiner. Connection to the mains by a certified electrician (not included) via a 2000mm lead with standard 10A 3-pin plug or 800mm lead with Elsafe 'J-coupler'

For additional technical information please contact Botton and Gardiner via info@bottonandgardiner.com.au

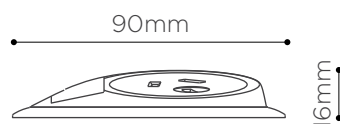
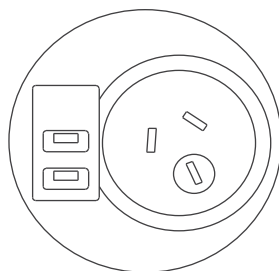

FGP

ACCESSORIES INFO



END TABLE

E.TB

The 600mm long End Table can be added to the left or right side of your straight or curved Bench modules.

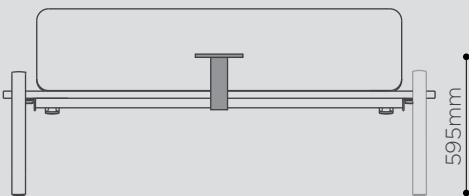
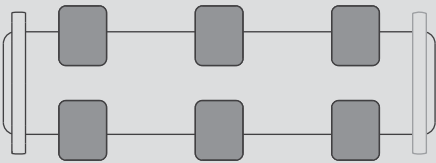

LAPTOP TABLE

L.TB

The 250 x 200mm Laptop Table can be added to the left, centre or right position on the Bench and the centre only position on the Seat. Available on straight and curved modules.



Hub

ACCESSORIES INFO



LAPTOP TABLE **L.T.B**

The 250 x 300mm Laptop Table can be added to the left, centre or right position on the 2400mm long units, and the left or right positions on the 1800mm long units.

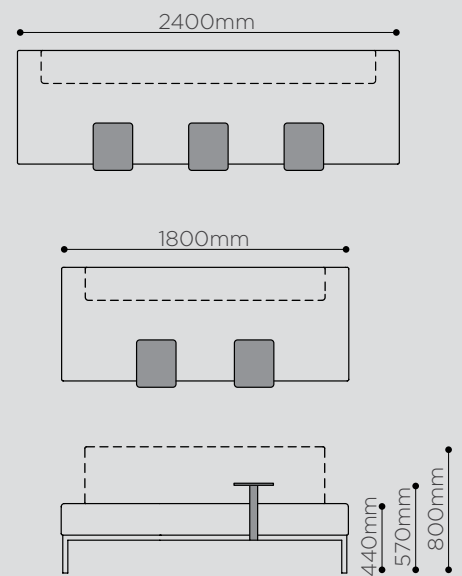

Locations below for the curved units.

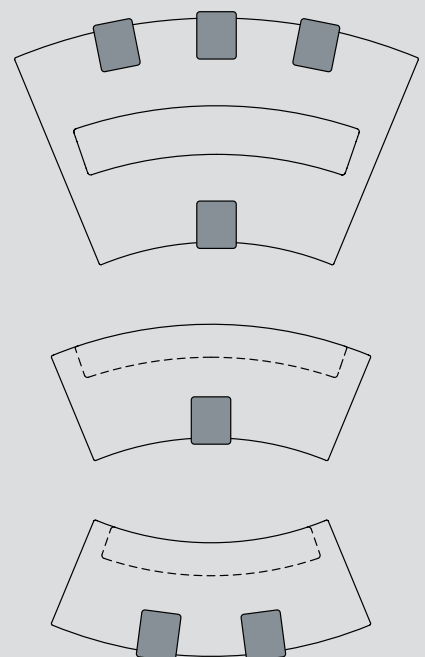

FIXING & ASSEMBLY



FGP COLLABORATIVE MODULAR SEATING

SURFACE FIXED FIXING DETAIL

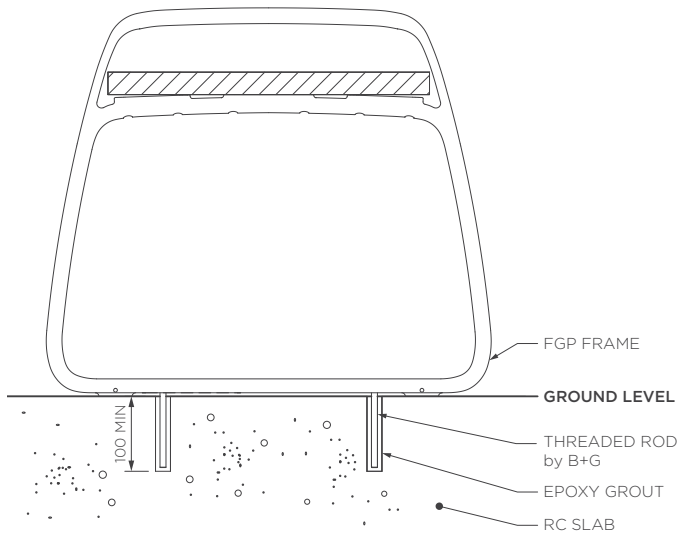

REMOVEABLE SURFACE FIXED FIXING DETAIL

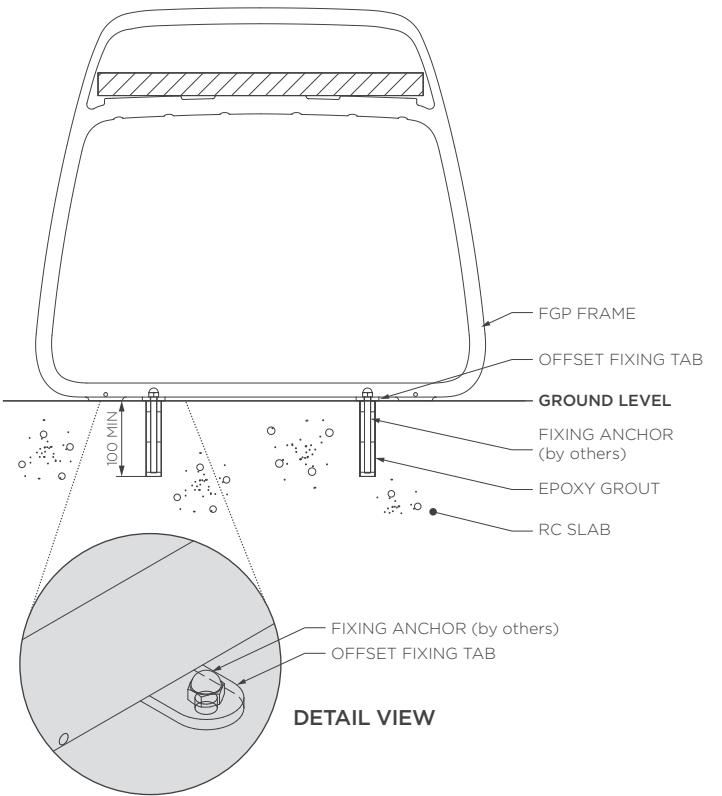

STABILITY SLED FOOT FREESTANDING DETAIL

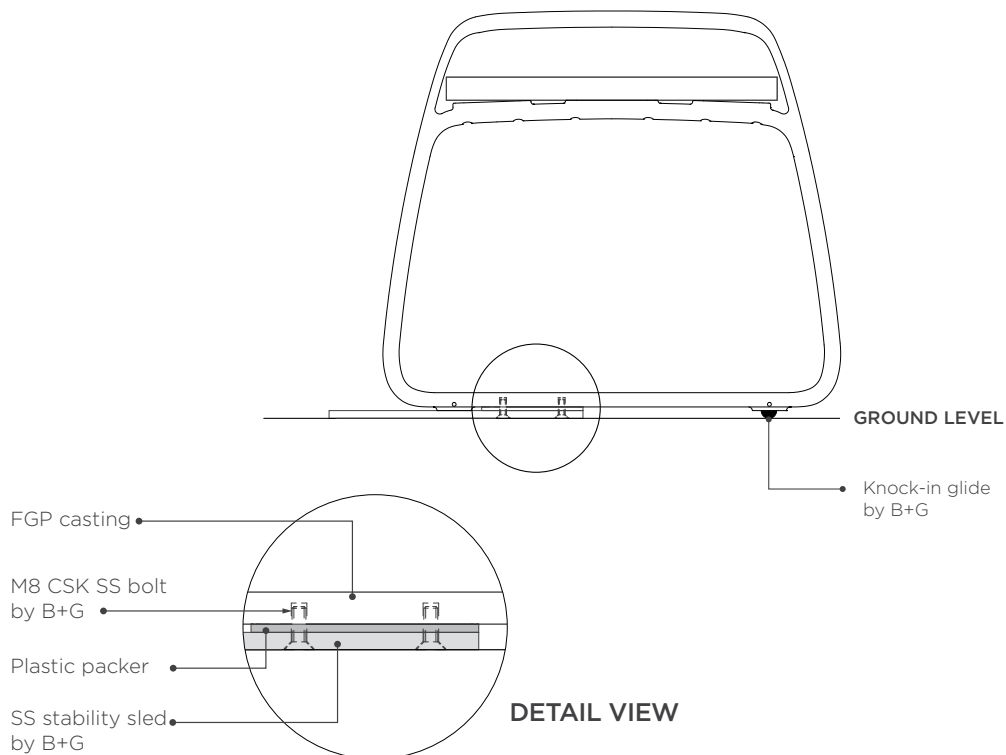

ATOMIK MODULAR POD ASSEMBLY INFO

STEP 1

PLACE YOUR MODULE ON IT'S SIDE ON A BLANKET OR SOFT SURFACE. TURN THE CONNECTOR ON THE UNDERSIDE 180 DEGREES (THIS PROTECTS YOUR UPHOLSTERY DURING TRANSPORT)

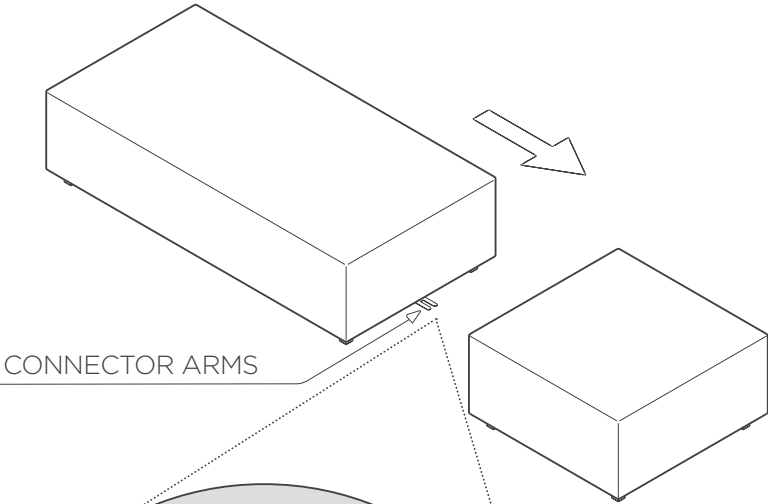

STEP 2

PULL MODULE TOGETHER

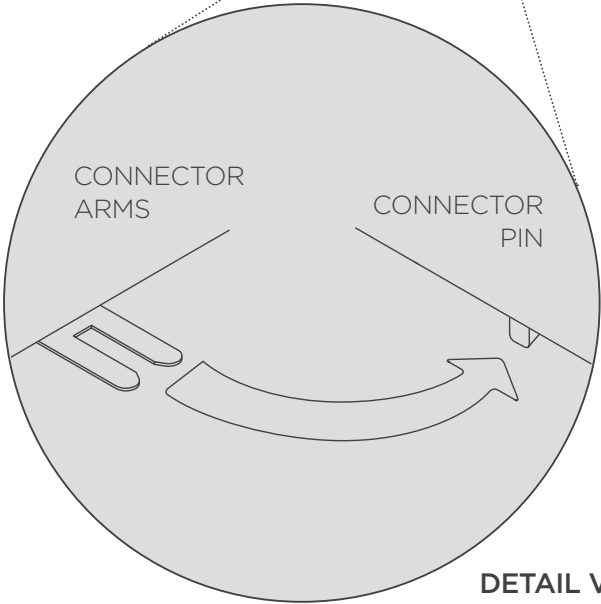

STEP 3

INVISIBLE CONNECTION

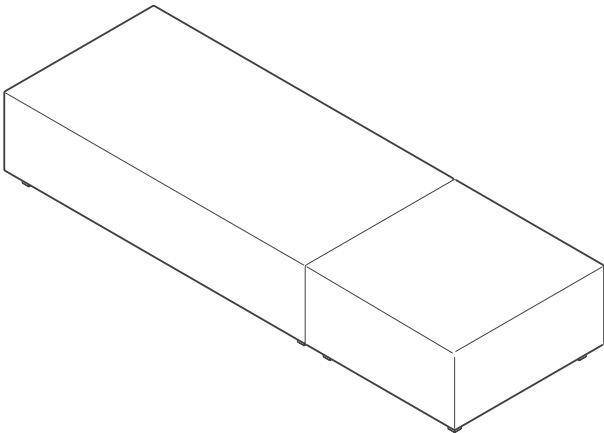

UNITS CAN BE DISASSEMBLED BY LIFTING THE END OF THE MODULE

STEP 4

REPEAT WITH OTHER MODULES IN YOUR POD

bottom + gardiner

PUBLIC SPACE FURNITURE

Ph: 1300 762 701
bottongardiner.com.au



A division of Baresque Australia Pty Ltd

