

PARTS AND HARDWARE

FOR A TYPICAL ASSEMBLY

OPEN RAFTER VERSION / QTY

5 X 5 4 X 5 3 X 5 2 X 5 1 X 5

8in MAIN BEAMS (96in)

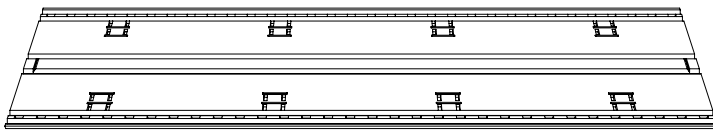

4in CONNECTING BEAM

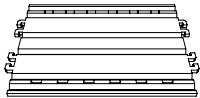

8in END BEAM

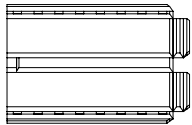

4in END BEAM

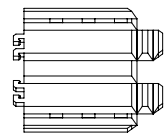

8in BEAM CONNECTOR

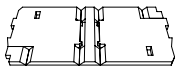

BEAMS CLIP



x6	x5	x4	x3	x2
x30	x24	x18	x12	x6
x12	x10	x8	x6	x4
x12	x12	x12	x12	x12
x12	x10	x8	x6	x4
x144	x122	x100	x78	x56

STEP 1

BEAMS ASSEMBLY

ASSEMBLE INDIVIDUALS PARTS AS PER PURCHASED PACKAGE.

FOLD 8IN MAIN BEAM AND SECURE IT BY INSERTING BEAMS CLIPS INTO PRE-CUT RECTANGULAR HOLES.

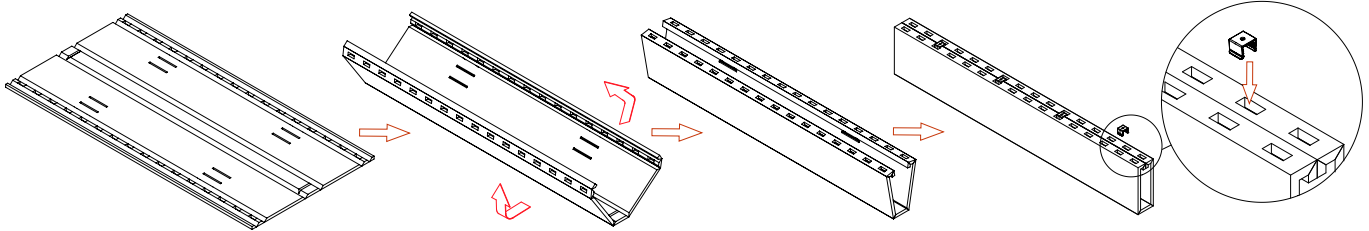

*BEAMS CLIPS QTY FOR 8IN MAIN BEAMS - x6

*IMPORTANT: DO NOT INSERT CLIPS INTO FIRST AND LAST HOLES OF THE MAIN BEAM

FOLD 4IN CONNECTING BEAM AND SECURE IT BY INSERTING BEAMS CLIPS INTO PRE-CUT RECTANGULAR HOLES.

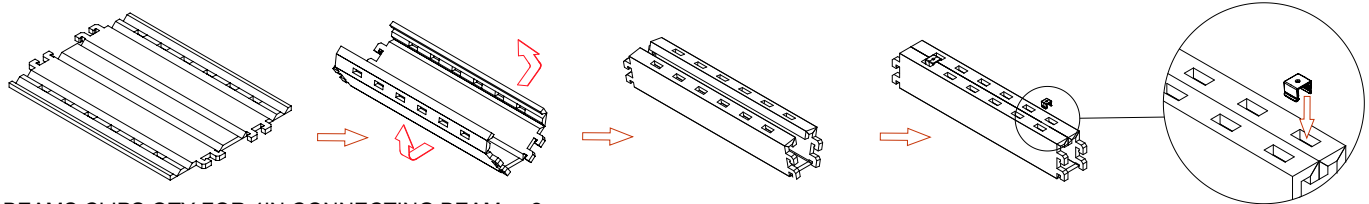

*BEAMS CLIPS QTY FOR 4IN CONNECTING BEAM - x2

FOLD 8IN END BEAM AND SECURE IT BY INSERTING BEAMS CLIPS INTO PRE-CUT RECTANGULAR HOLES.

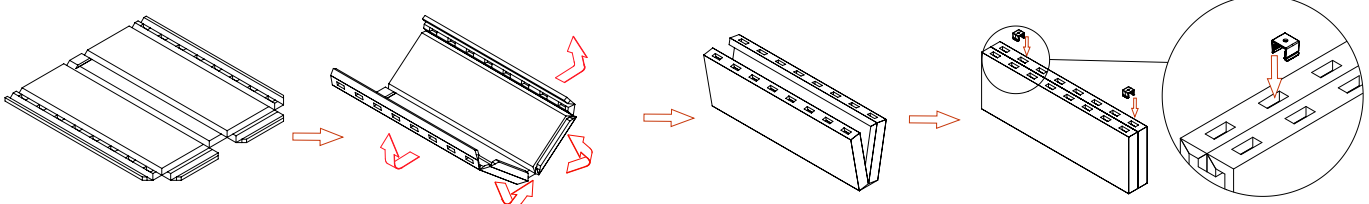

*BEAMS CLIPS QTY FOR 8IN END BEAM - x2

*IMPORTANT: ON OPEN END DO NOT INSERT CLIP INTO FIRST HOLE OF THE BEAM

FOLD 4IN END BEAM AND SECURE IT BY INSERTING BEAMS CLIPS INTO PRE-CUT RECTANGULAR HOLES.

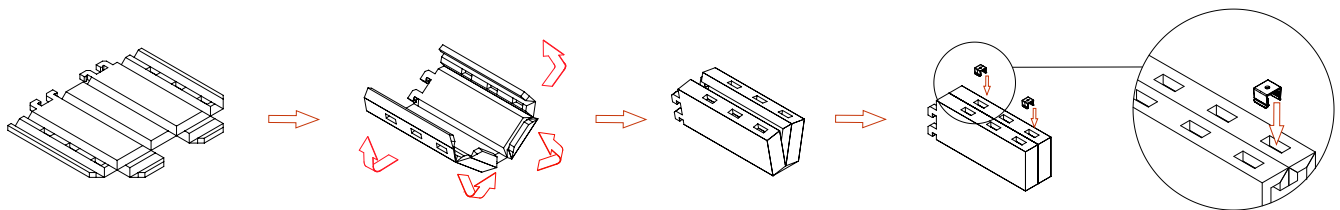

*BEAMS CLIPS QTY FOR 4IN END BEAM - x2

FOLD 8IN BEAM CONNECTOR AND SECURE IT BY INSERTING INTO PRE-CUT RECTANGULAR HOLES.

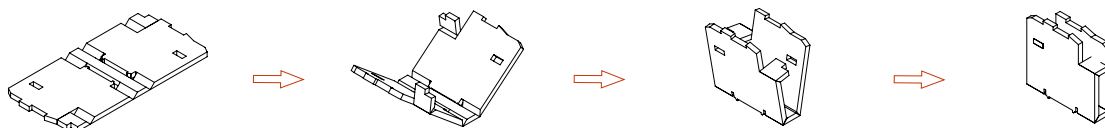

STEP 2

PREPARING 8IN MAIN BEAMS BEFORE ASSEMBLY

REMOVE PRE-CUT RECTANGULAR HOLES ON BOTH SIDES. REMOVE PRE-CUT RECTANGULAR HOLES BY PUSHING THEM INSIDE

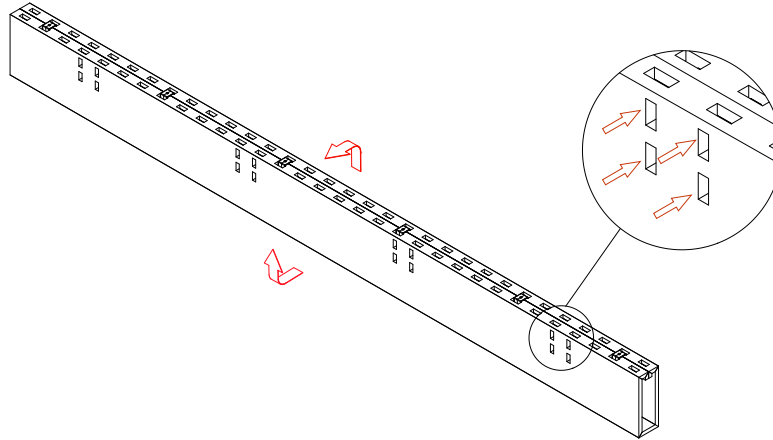

STEP 3

8IN BEAMS CONNECTOR INSTALL

3.1 INSERT 8IN BEAMS CONNECTORS INTO THE ENDS OF 8IN MAIN BEAMS AS SHOWN.

3.2 WITH THE HELP OF FINGER RISE THE TOP OF 8IN MAIN BEAM FOR EASY INSERT.

3.3 INSERT THE 8IN BEAMS CONNECTOR INTO THE CORRESPONDING PRE-CUT RECTANGULAR HOLES IN THE 8IN MAIN BEAM.

3.4 REPEAT STEPS 3.1 - 3.3 FOR EACH 8IN BEAMS CONNECTOR UNTIL THE ASSEMBLY AS SHOWN HAS BEEN COMPLETED.

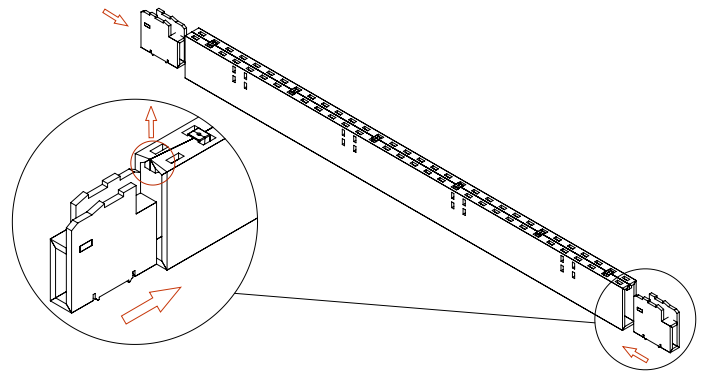

STEP 4

8IN END BEAMS INSTALL

4.1 INSERT 8IN END BEAM INTO BEAM COONECTOR FROM THE STEP 3 ASSEMBLY AS SHOWN.

4.2 USE 3.2 AND 3.3 STEPS FOR END BEAMS INSTALL.

4.3 REPEAT STEPS 4.1 - 4.2 FOR EACH 8IN END BEAMS UNTIL THE ASSEMBLY AS SHOWN HAS BEEN COMPLETED.

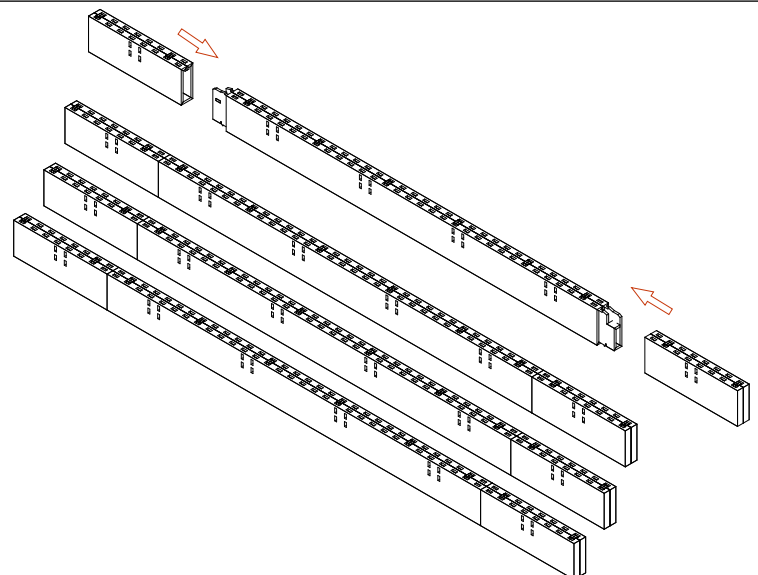

STEP 5

4IN CONNECTING BEAMS INSTALL

5.1 INSERT THE 4IN CONNECTING BEAMS INTO THE CORRESPONDING PRE-CUT RECTANGULAR HOLES IN THE 8IN MAIN BEAM.

5.2 AFTER INSERTING, PUSH 4IN CONNECTING BEAM DOWN TILL YOU HEAR LOCKING SOUND AND TOP SURFACES ARE FLUSH.

5.3 REPEAT STEPS 3.1 - 3.2 FOR EACH 4IN CONNECTING BEAM UNTIL THE ASSEMBLY AS SHOWN HAS BEEN COMPLETED.

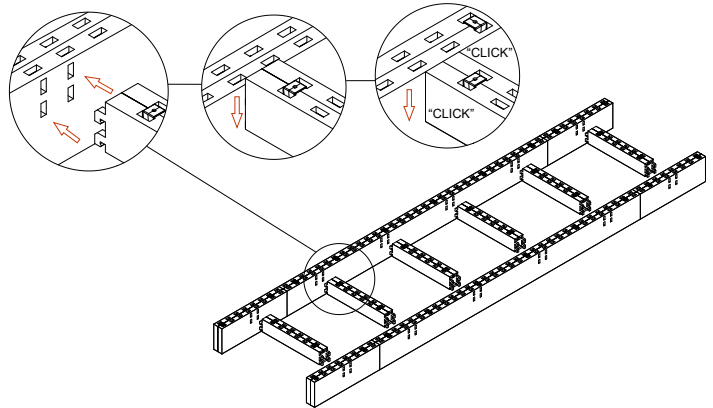

STEP 6

4IN END BEAM INSTALL - FINISNG INSTALL

REPEATING STEPS 5.1 - 5.3 INSTALL 4IN END BEAMS AS SHOWN.

