

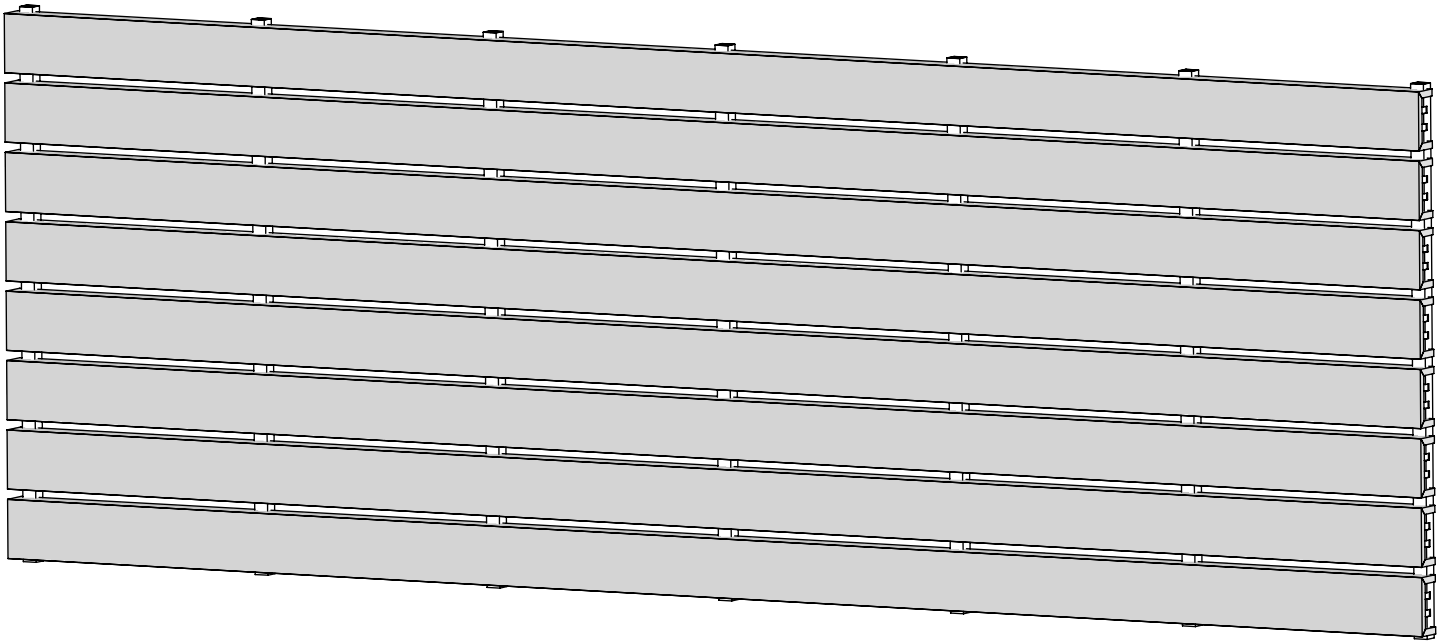

ZINTRA STICKS

STANDARD LANDSCAPE ASSEMBLY INSTALLATION INSTRUCTIONS



ZINTRA STICKS

STANDARD LANDSCAPE ASSEMBLY INSTALLATION INSTRUCTIONS

PARTS AND HARDWARE

FOR A TYPICAL ASSEMBLY

ZINTRA STICKS - (8) WIDE OR (16) NARROW

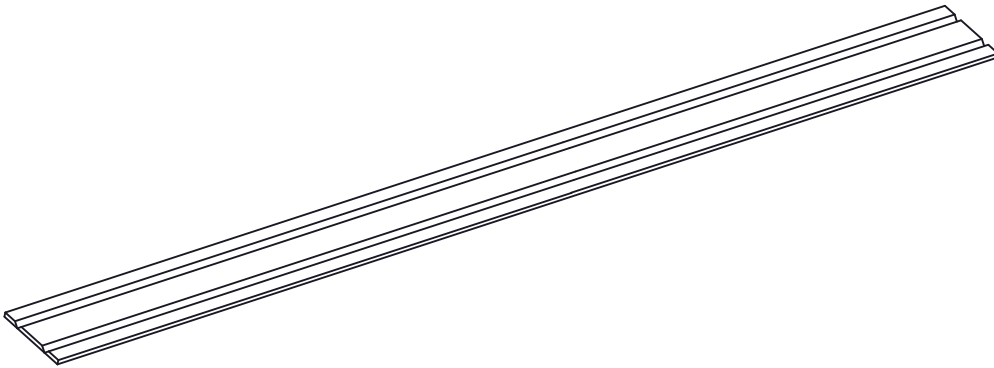

(7) STANDARD ALUMINIUM TUBE WITH NOTCHES

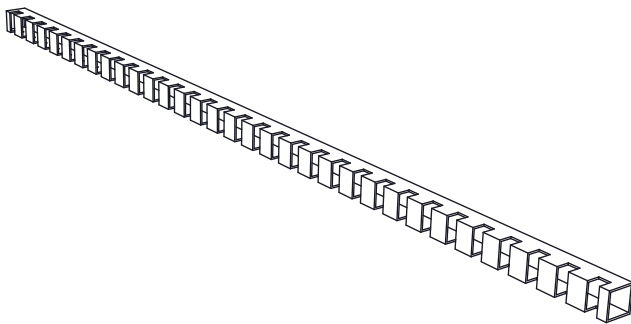

ZINTRA STICKS

STANDARD LANDSCAPE ASSEMBLY INSTALLATION INSTRUCTIONS

YOU WILL NEED

(14) SUITABLE SCREWS

SCREWS ARE NOT INCLUDED - INSTALLER TO SUPPLY BASED ON FIXING SUBSTRATE

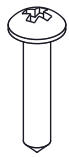

SPIRIT LEVEL

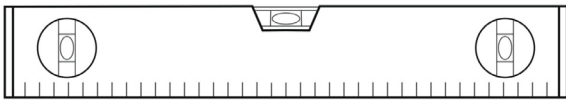

DROP SAW WITH SUITABLE BLADE FOR ALUMINIUM CUTTING

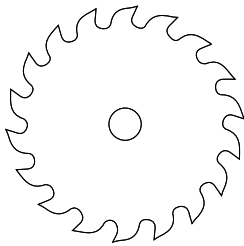

DRILL

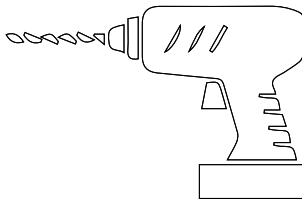

TAPE MEASURE

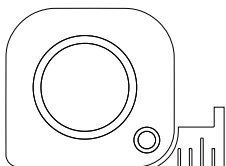

ZINTRA STICKS

STANDARD LANDSCAPE ASSEMBLY

INSTALLATION INSTRUCTIONS

STEP 1

MEASURE THE HEIGHT [X] OF THE INSTALL AND CUT THE ALUMINIUM TO SUIT

NOTE: AFTER MEASURING AND MARKING WHERE TO CUT THE ALUMINIUM TUBE, COUNT THE NUMBER OF NOTCHES TO ENSURE IT WILL SUIT THE QUANTITY OF STICKS REQUIRED. FOR EXAMPLE, A WIDE STICK USES 4 NOTCHES, THEREFORE THE NOTCHES IN THE ALUMINIUM TUBE WILL NEED TO EQUAL A MULTIPLE OF 4.

USE A LASER LEVEL OR SPIRIT LEVEL TO MARK ALUMINIUM POSITION ON THE WALL.

MAX DISTANCE FROM TUBE CENTRES IS 450mm [17.71"]

MAX DISTANCE BETWEEN END OF STICK AND FIRST TUBE CENTRE IS 150mm [5.9"]

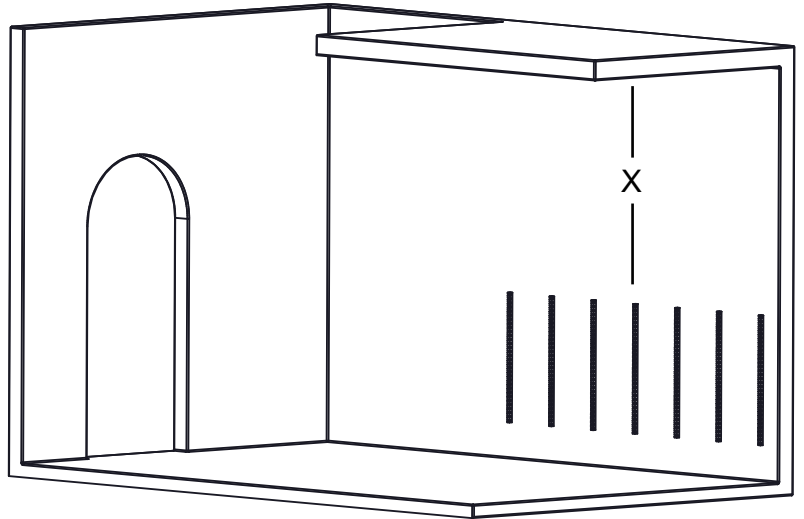

STEP 2

DRILL HOLES IN ALUMINIUM TUBES IN LOCATIONS TO SUIT SUPPORT IN WALL (STUD LOCATION ETC)

SCREW ALUMINIUM TUBES TO WALL

DRYWALL SURFACE: USE DRYWALL ANCHOR AND SUITABLE SCREW

TIMBER SURFACE: USE SELF TAPPING TIMBER SCREW

MASONARY SURFACE: USE MASONARY ANCHOR AND SUITABLE SCREW

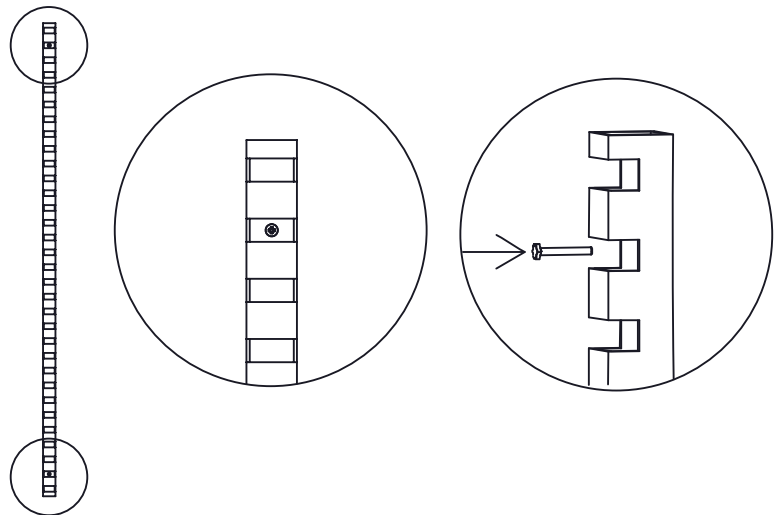

STEP 3

FOLD ZINTRA STICKS (8) FOR WIDE OR (16) FOR NARROW

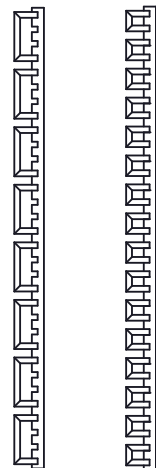
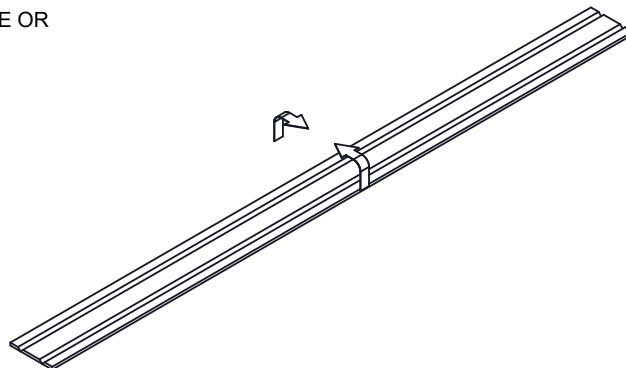

WIDE NARROW

ZINTRA STICKS

STANDARD LANDSCAPE ASSEMBLY

INSTALLATION INSTRUCTIONS

STEP 4

INSERT ZINTRA STICKS INTO TUBE NOTCHES
AS SHOWN

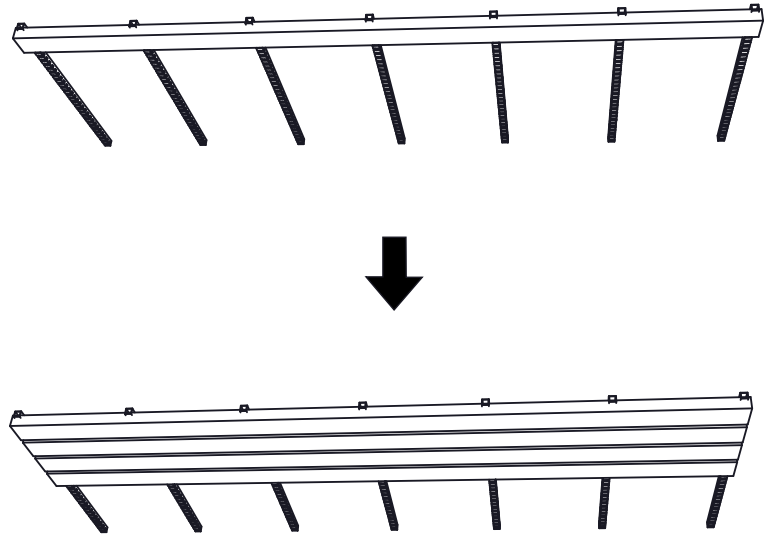
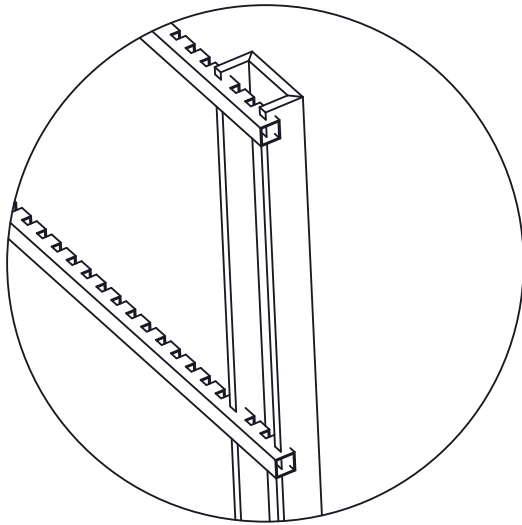

FINISHED INSTALL

NOTE: CAN ADD STICKS TRIM TO EDGES (SIDES OR BOTTOM)
FOR ALTERNATE FINISH

