

ZINTRA STICKS

EXTERNAL CORNER PORTRAIT ASSEMBLY INSTALLATION INSTRUCTIONS

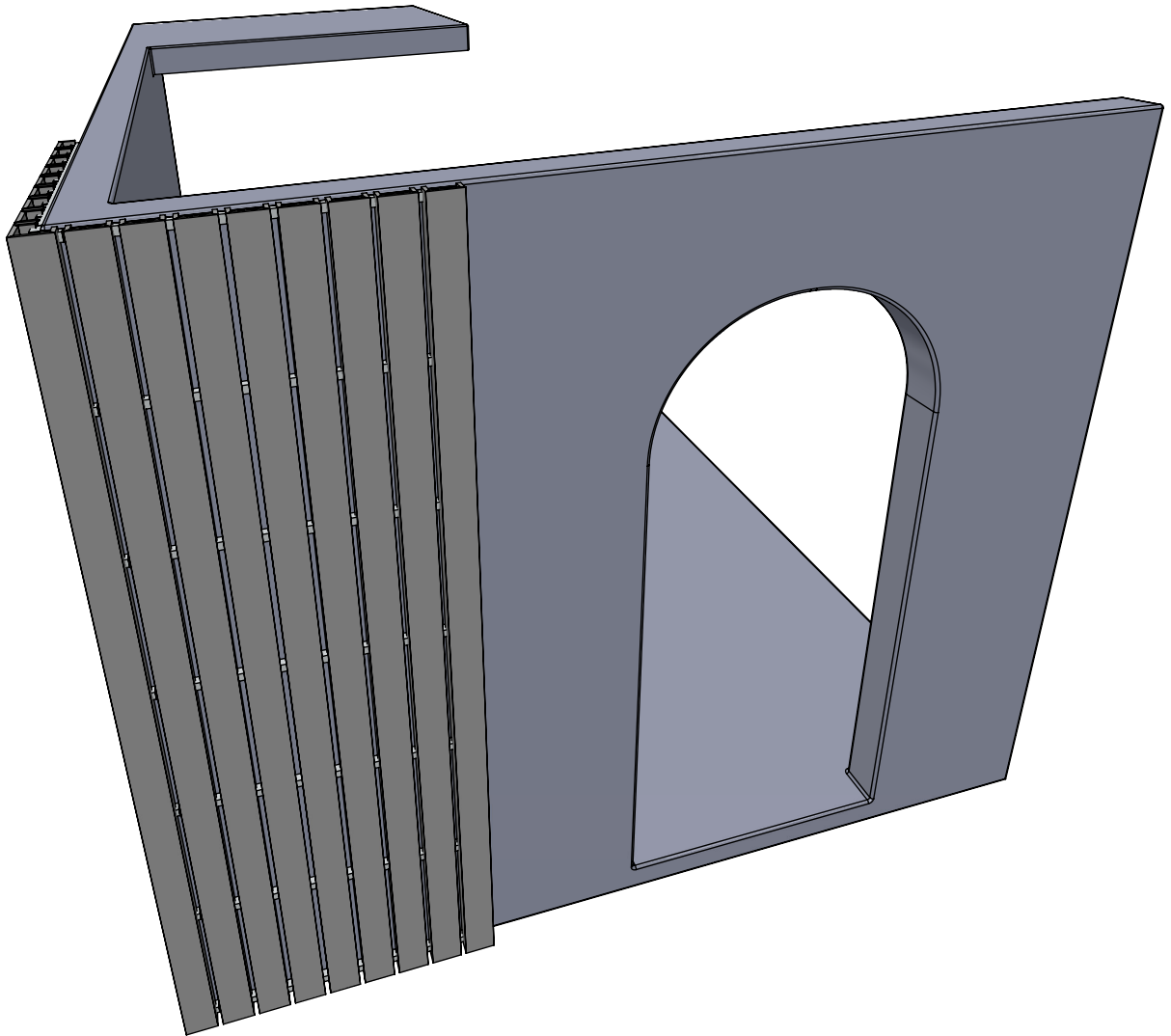

ZINTRA STICKS

EXTERNAL CORNER PORTRAIT ASSEMBLY

INSTALLATION INSTRUCTIONS

PARTS AND HARDWARE

FOR A TYPICAL ASSEMBLY

ZINTRA STICKS - (8) WIDE OR (16) NARROW

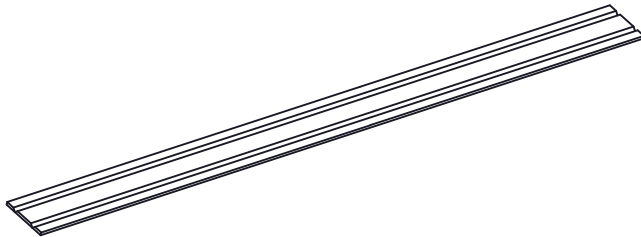

(14) STANDARD ALUMINIUM TUBE WITH NOTCHES

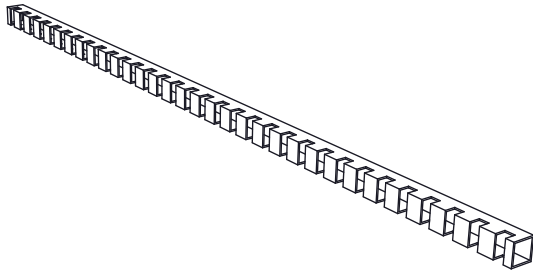

(14) STANDARD ALUMINIUM TUBE WITH NOTCHES - EXTERNAL CORNER

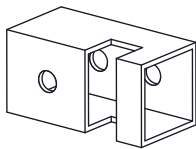

(1) ZINTRA STICK - EXTERNAL CORNER

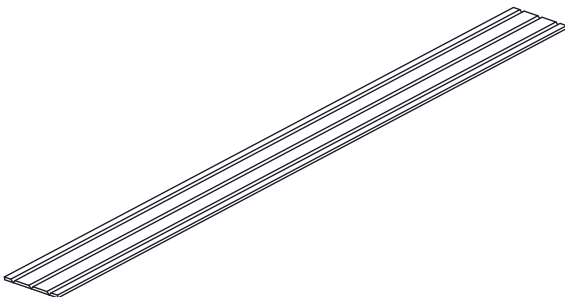

ZINTRA STICKS

EXTERNAL CORNER PORTRAIT ASSEMBLY

INSTALLATION INSTRUCTIONS

YOU WILL NEED

(56) SUITABLE SCREWS

SCREWS ARE NOT INCLUDED - INSTALLER TO SUPPLY BASED ON FIXING SUBSTRATE



SPIRIT LEVEL

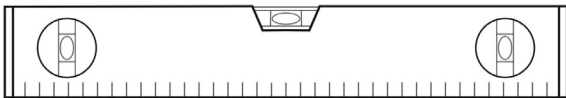

DROP SAW WITH SUITABLE BLADE FOR ALUMINIUM CUTTING

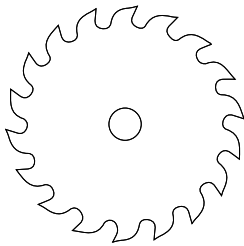

DRILL

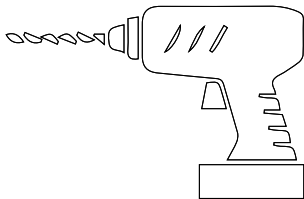

TAPE MEASURE

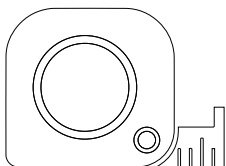

ZINTRA STICKS

EXTERNAL CORNER PORTRAIT ASSEMBLY

INSTALLATION INSTRUCTIONS

STEP 1

MEASURE THE WIDTH [X] OF THE INSTALL AND CUT THE ALUMINIUM TO SUIT

NOTE: AFTER MEASURING AND MARKING WHERE TO CUT THE ALUMINIUM TUBE, COUNT THE NUMBER OF NOTCHES TO ENSURE IT WILL SUIT THE QUANTITY OF STICKS REQUIRED. FOR EXAMPLE, A WIDE STICK USES 4 NOTCHES, THEREFORE THE NOTCHES IN THE ALUMINIUM TUBE WILL NEED TO EQUAL A MULTIPLE OF 4.

USE A LASER LEVEL OR SPIRIT LEVEL TO MARK ALUMINIUM POSITION ON THE WALL.

THESE WILL REQUIRE (2) SCREWS PER (1) ALUMINIUM EXTERNAL CORNER PIECE (28 TOTAL SCREWS)

INSTALL ALUMINIUM TUBE NOTCHES - EXTERNAL CORNER AT THE CORNER OF THE WALL SECTION AS SHOW.

MAX DISTANCE FROM TUBE CENTRES IS 450mm [17.71"]

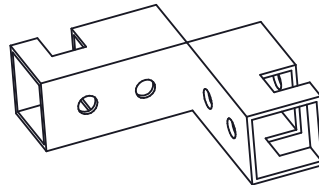

BACK PERSPECTIVE

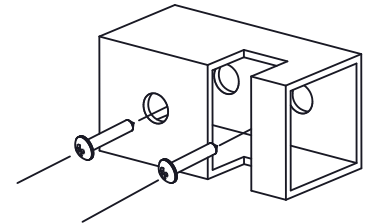

FRONT PERSPECTIVE

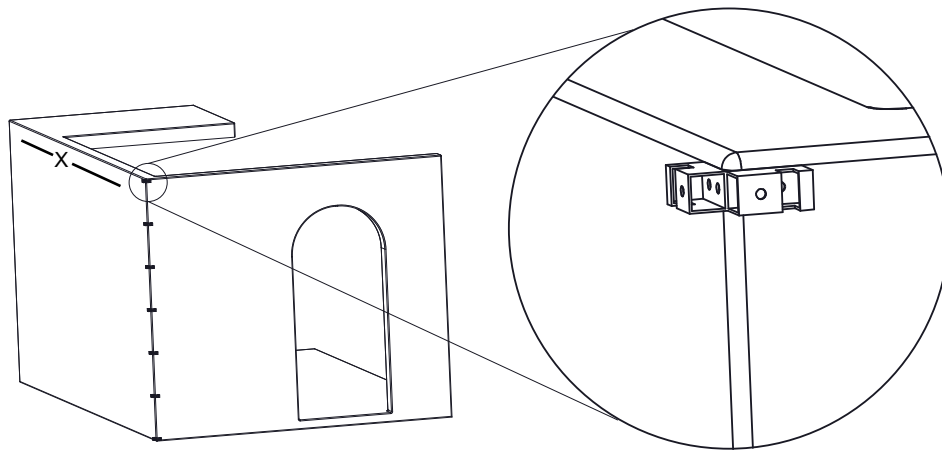

STEP 2

USE A LASER LEVEL OR SPIRIT LEVEL TO MARK ALUMINIUM POSITION ON THE WALL

MAX DISTANCE FROM TUBE CENTRES IS 450mm [17.71"]

MAX DISTANCE BETWEEN END OF STICK AND FIRST TUBE CENTRE IS 150mm [5.9"]

INSTALL (7) STANDARD ALUMINIUM TUBE WITH NOTCHES EACH SIDE OF THE EXTERNAL CORNER PIECES (14 TOTAL) MAKE SURE THESE ARE IN-LINE WITH THE CORNER PIECES

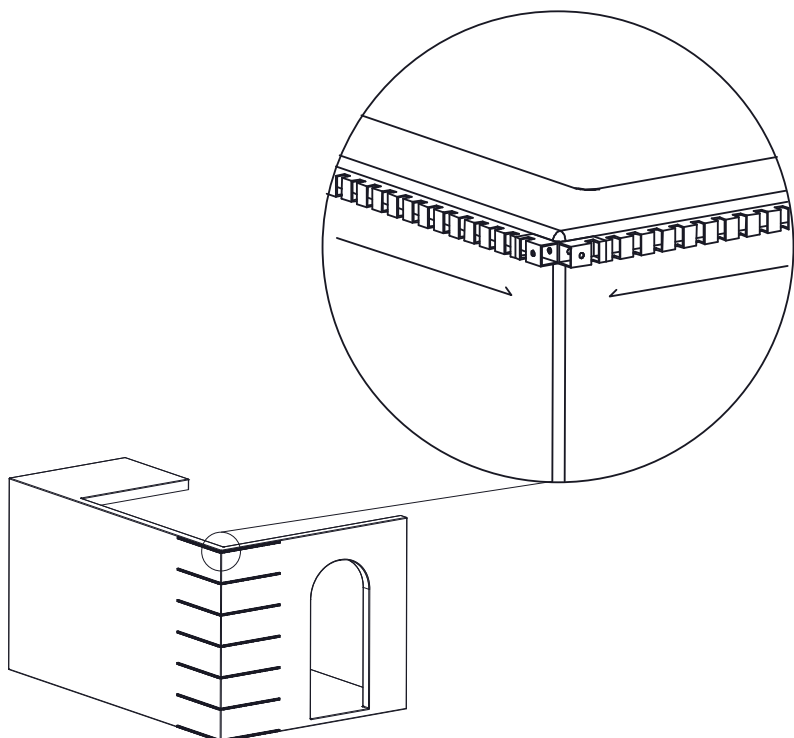

ZINTRA STICKS

EXTERNAL PORTRAIT CORNER ASSEMBLY

INSTALLATION INSTRUCTIONS

STEP 3

DRILL HOLES IN ALUMINIUM TUBES IN LOCATIONS TO SUIT SUPPORT IN WALL (STUD LOCATION ETC)

SCREW ALUMINIUM TUBES TO WALL

DRYWALL SURFACE: USE DRYWALL ANCHOR AND SUITABLE SCREW

TIMBER SURFACE: USE SELF TAPPING TIMBER SCREW

MASONARY SURFACE: USE MASONARY ANCHOR AND SUITABLE SCREW

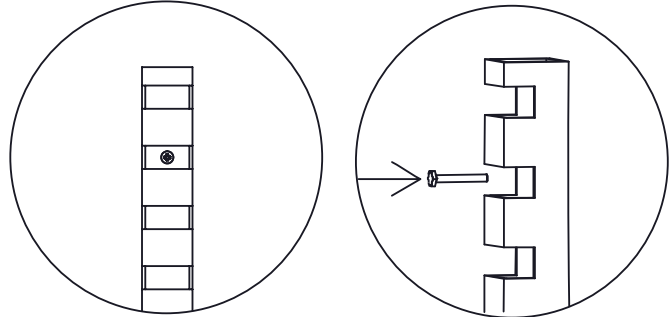

STEP 4

FOLD ZINTRA STICKS (8) FOR WIDE OR (16) FOR NARROW

FOLD (1) ZINTRA STICK - EXTERNAL CORNER

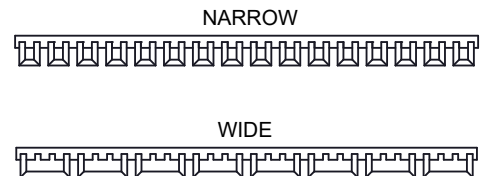
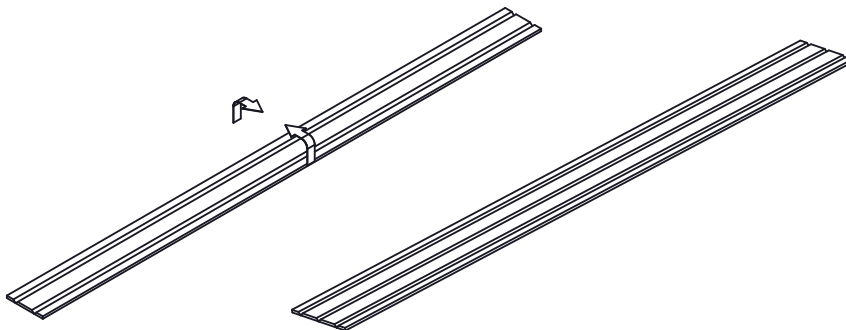

ZINTRA STICKS

EXTERNAL PORTRAIT CORNER ASSEMBLY

INSTALLATION INSTRUCTIONS

STEP 5

INSERT ZINTRA STICK - EXTERNAL CORNER INTO
TUBE NOTCHES - EXTERNAL CORNER

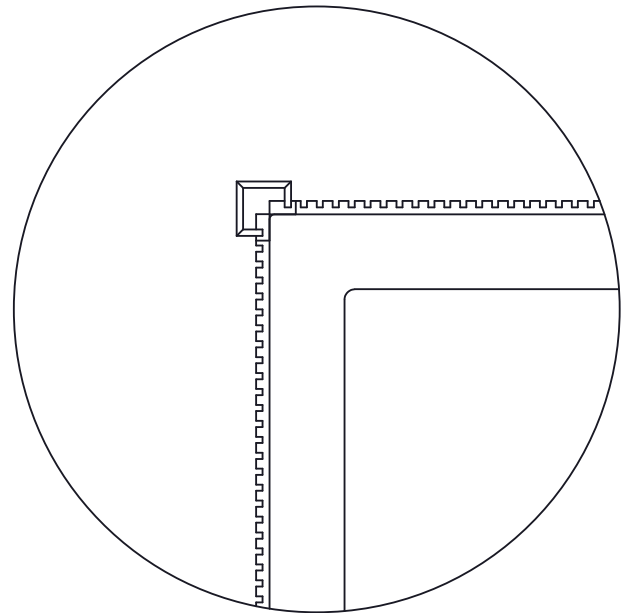

TOP VIEW OF EXTERNAL CORNER STICK
ATTACHED TO CORNER OF THE WALL

ZINTRA STICKS

EXTERNAL PORTRAIT CORNER ASSEMBLY

INSTALLATION INSTRUCTIONS

STEP 6

INSERT ALL STICKS INTO ALUMINIUM TUBES
AS SHOWN BELOW

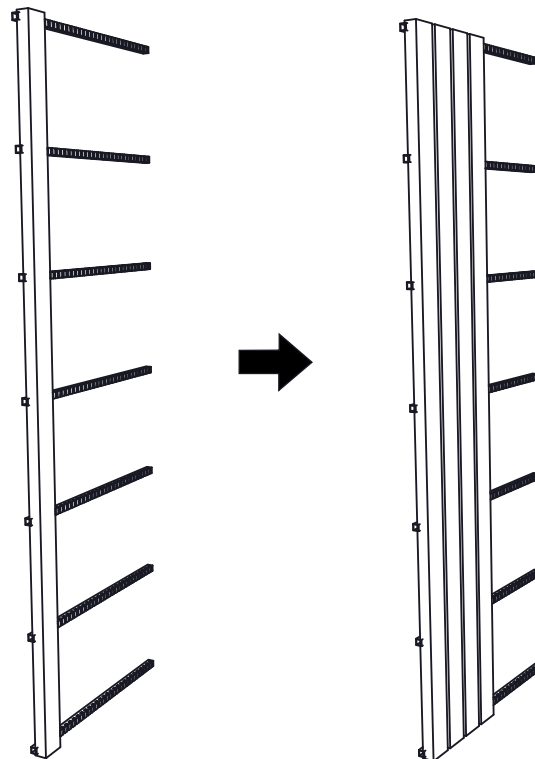
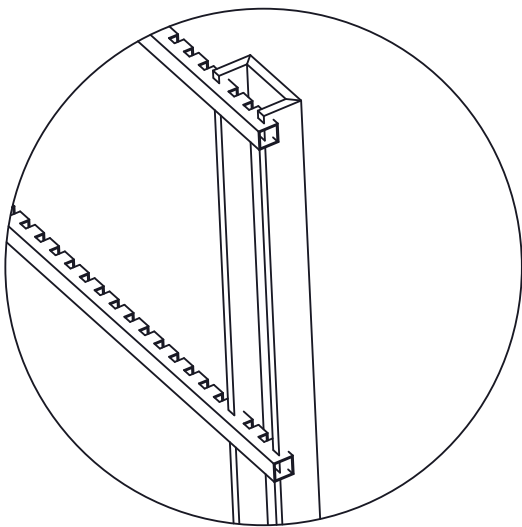
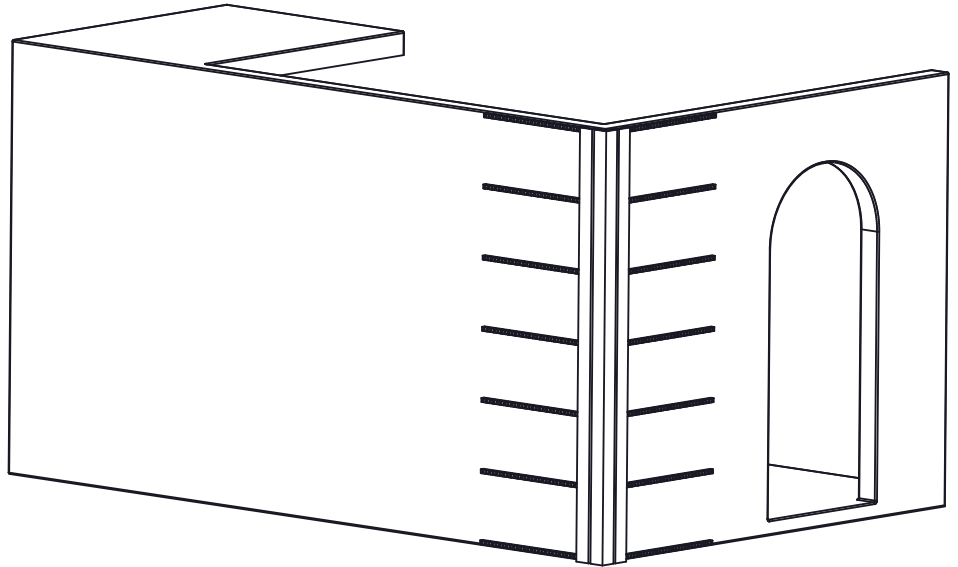

ZINTRA STICKS

EXTERNAL PORTRAIT CORNER ASSEMBLY

INSTALLATION INSTRUCTIONS

FINISHED INSTALL

