

# ZINTRA CLOUDS

## LONG DOME - CONVEX

### INSTALLATION INSTRUCTIONS

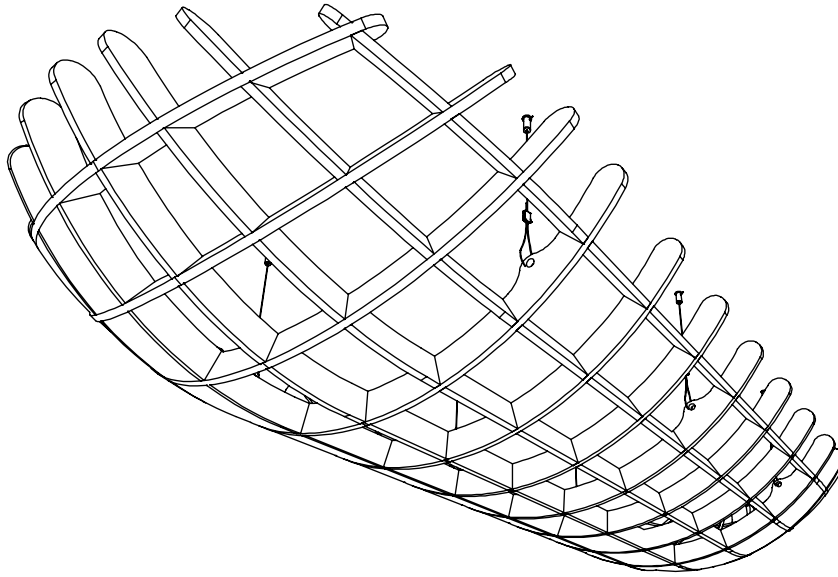

BOTTOM PERSPECTIVE

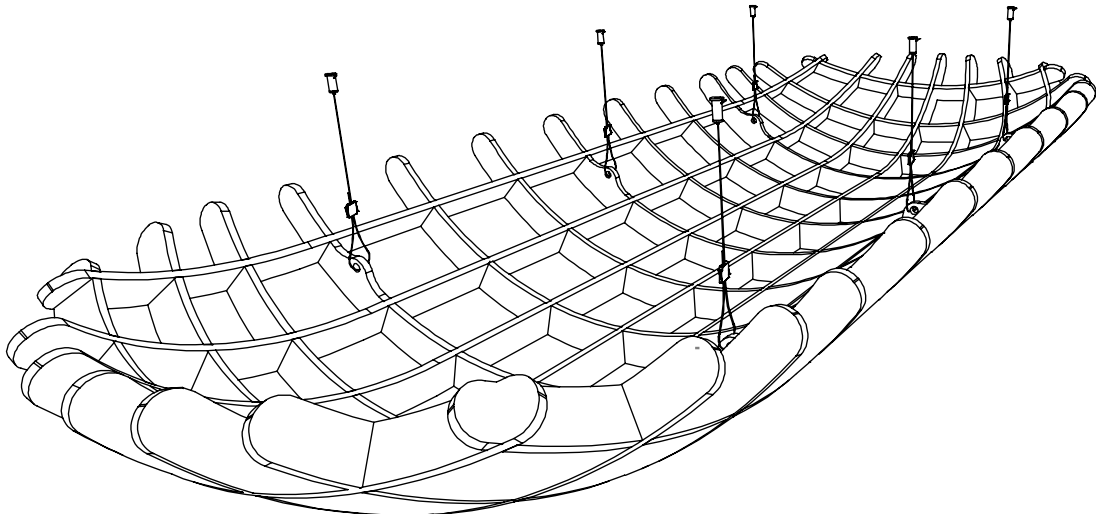

TOP PERSPECTIVE

# ZINTRA CLOUDS

## LONG DOME - CONVEX

### INSTALLATION INSTRUCTIONS

## PARTS AND HARDWARE

ZINTRA CLOUDS - CONVEX

PARTS WILL COME FLAT PACKED WITH A TOTAL OF 14 PARTS

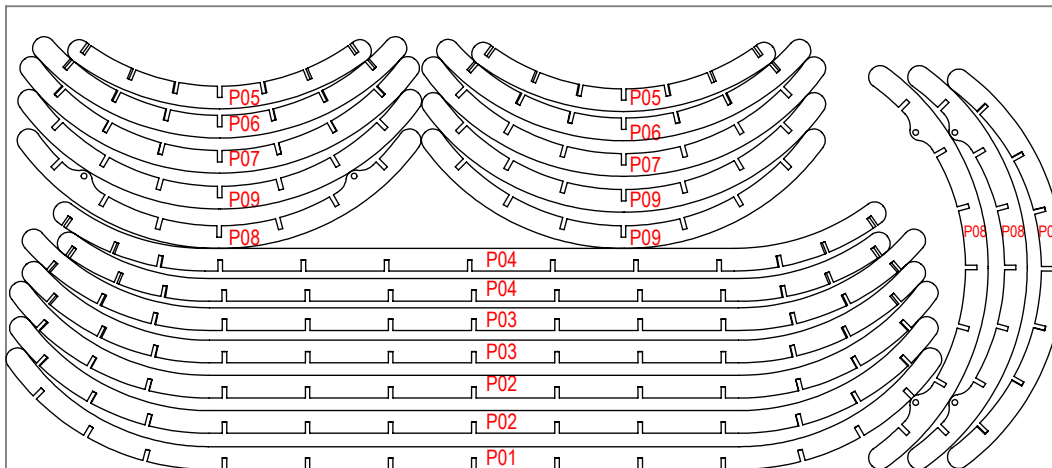

TOTAL PARTS: 20

P01: 1  
P02: 2  
P03: 2  
P04: 2  
P05: 2  
P06: 2  
P07: 2  
P08: 3  
P09: 4

(6) 1/4" - 20 HANGER BOLT (FOR USE WITH WOOD SUBSTRATE ONLY)



(6) ADJUSTABLE FASTENER



(6) CABLE WITH SWAGE END, AND BARREL

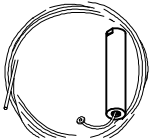

# ZINTRA CLOUDS

## LONG DOME - CONVEX

### INSTALLATION INSTRUCTIONS

## YOU WILL NEED

SPIRIT LEVEL

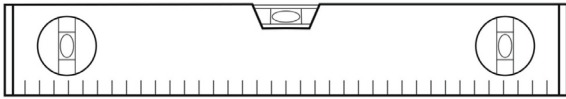

DROP SAW WITH SUITABLE BLADE FOR ALUMINIUM CUTTING

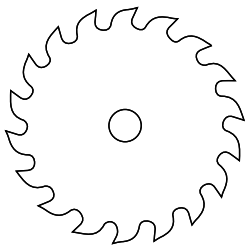

DRILL

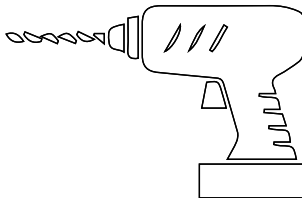

TAPE MEASURE

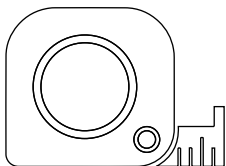

# ZINTRA CLOUDS

## LONG DOME - CONVEX

### INSTALLATION INSTRUCTIONS

#### STEP 1

CHECK TO SEE IF PACKAGE CONTAINS ALL COMPONENTS. EVERY PART WILL COME WITH A NUMBER (FROM 1-8) TO REPRESENT THE CLOUD NUMBER.

THERE WILL BE A TOTAL OF 20 CLOUD PARTS:

- P01: 1
- P02: 2
- P03: 2
- P04: 2
- P05: 2
- P06: 2
- P07: 2
- P08: 3
- P09: 4

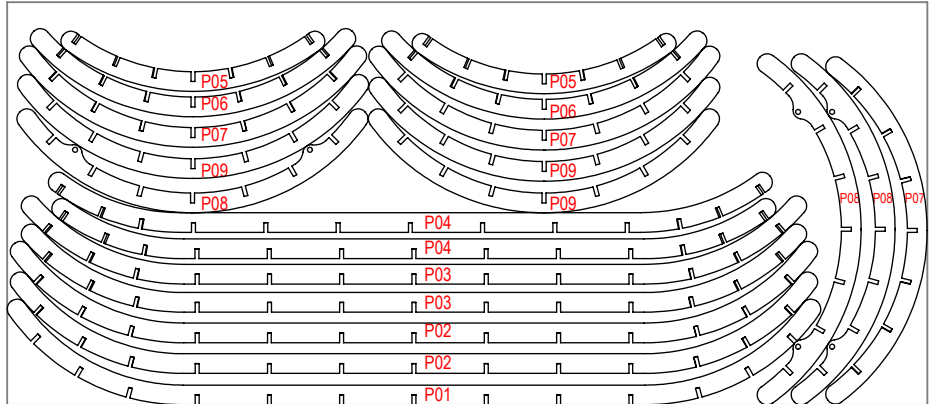

AND (6) OF EACH: HANGER BOLT, ADJUSTABLE FASTENER, CABLE WITH SWAGE END AND BARREL.



(6)



(6)

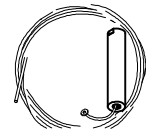

(6)

#### STEP 2

CONNECT P01 TO THE THREE HANGER PIECES (P08) AS SHOWN.

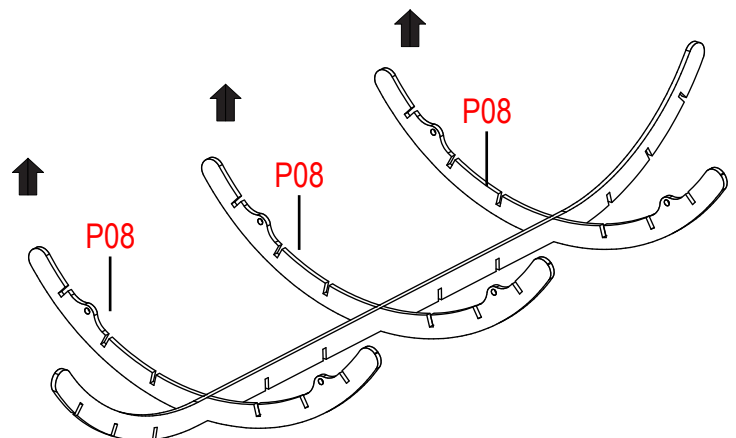
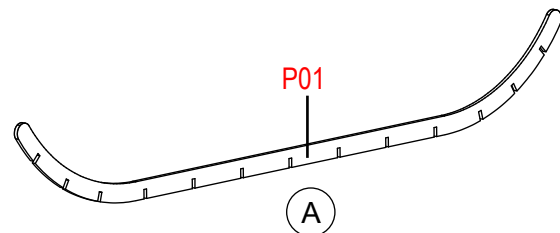

# ZINTRA CLOUDS

## LONG DOME - CONVEX

### INSTALLATION INSTRUCTIONS

#### STEP 3

ADD PORTRAIT CLOUDS (LONGER) WORKING FROM THE INNER CLOUDS TO OUTER AS SHOWN FROM STEPS A TO C.

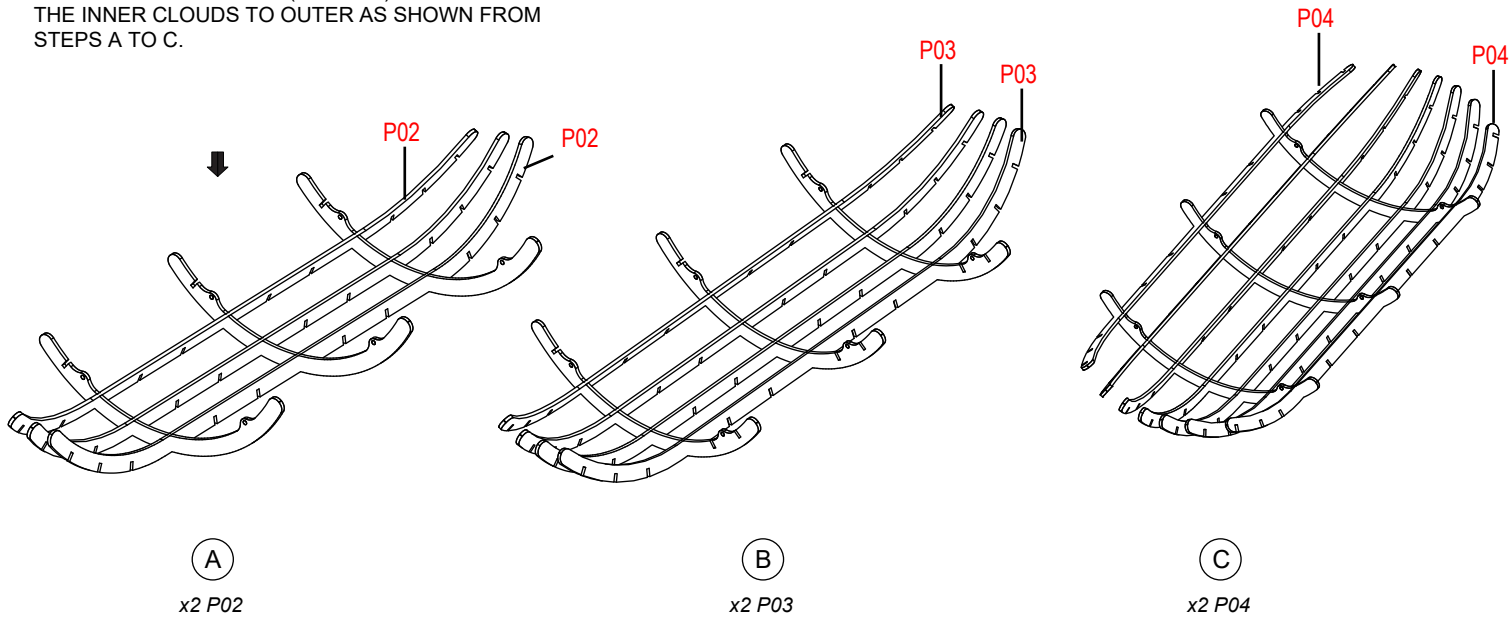

#### STEP 4

**IMPORTANT NOTE:** FOR THE FOLLOWING STEP MAKE SURE THE NOTCHES ARE FACING TOWARDS THE CENTRE. THIS IS TO ALLOW FOR THE REMANING CLOUDS TO FOLLOW THE "DOME" PROFILE.

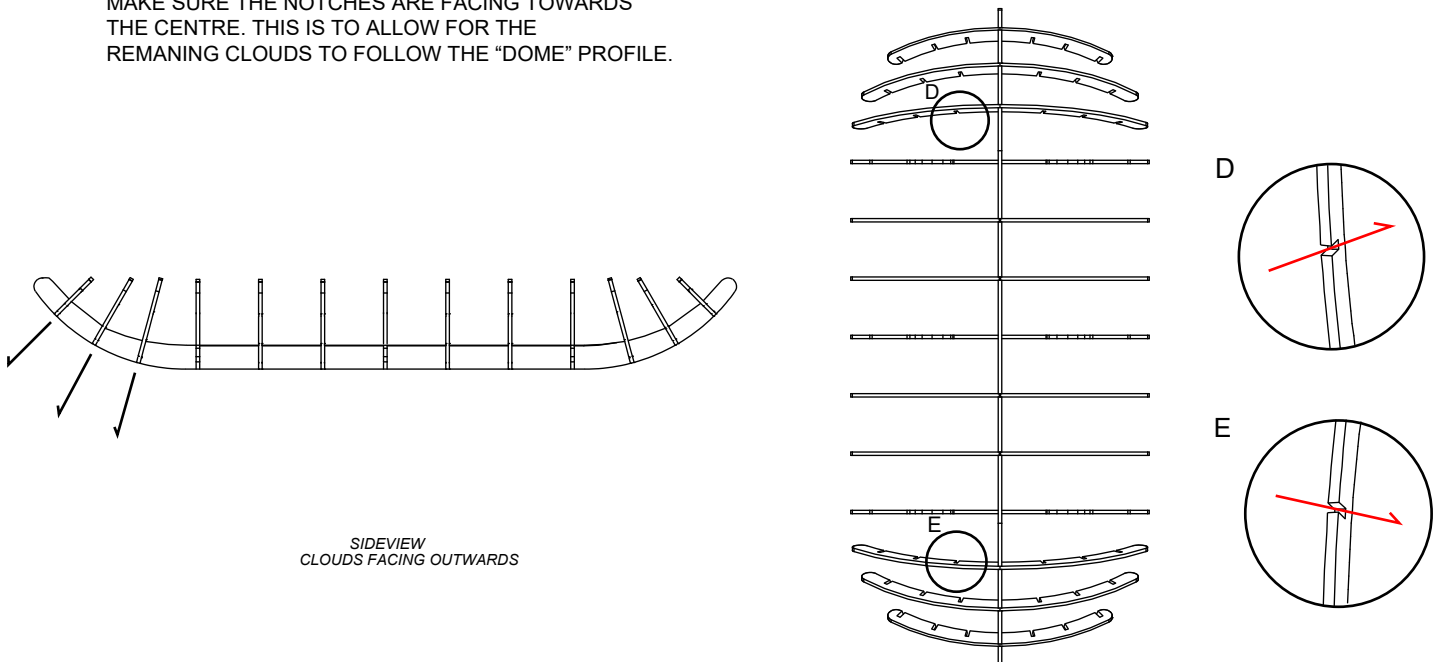

# ZINTRA CLOUDS

## LONG DOME - CONVEX

### INSTALLATION INSTRUCTIONS

#### STEP 5

ADD HORIZONTAL CLOUDS (SHORTER) TO ACT AS INTERNAL RIBBING STRUCTURE WORKING FROM THE INNER CLOUDS TO OUTER AS SHOWN FROM STEPS A TO B.

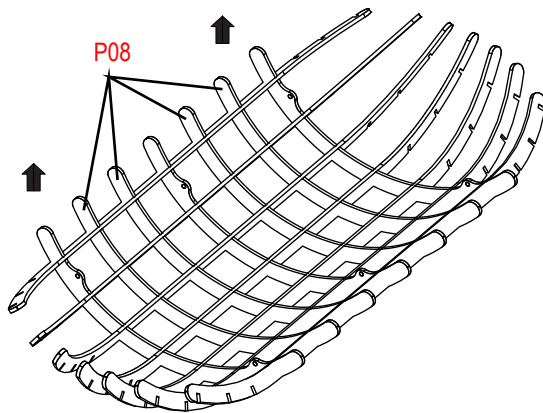

(A)

x4 P08

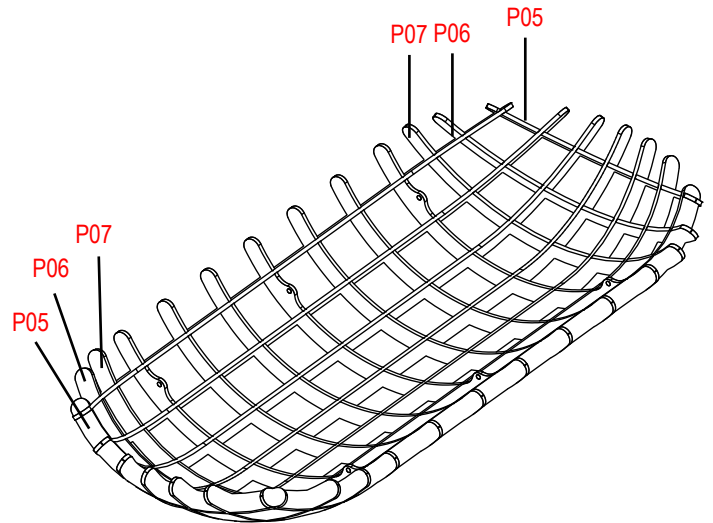

(B)

x2 P05, x2 P06, x2 P07

#### STEP 6

**IMPORTANT NOTE: (SAME AS STEP 4)**

MAKE SURE THE NOTCHES ARE FACING OUTWARDS FROM THE CENTRE. THIS IS TO ALLOW FOR THE REMAINING CLOUDS TO FOLLOW THE "DOME" PROFILE.

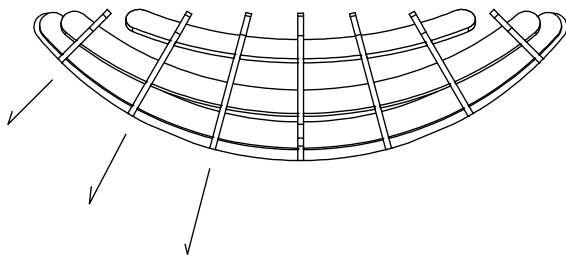

FRONT VIEW  
CLOUDS FACING OUTWARDS

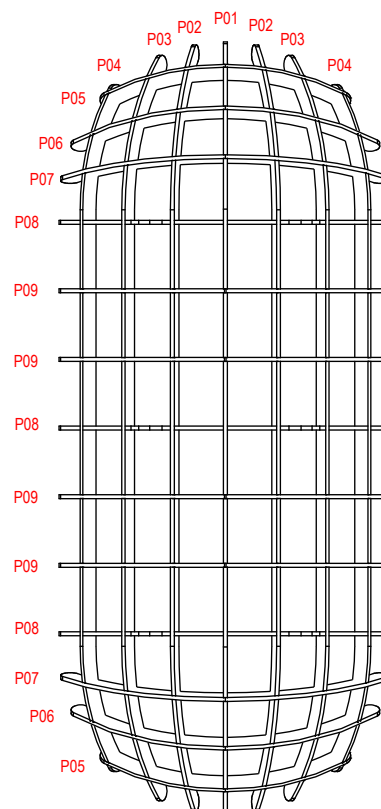

# ZINTRA CLOUDS

## LONG DOME - CONVEX

### INSTALLATION INSTRUCTIONS

#### STEP 7

A. FIND THE MIDPOINT OF EACH A.S.K (LOCATED ON P08). DIMENSION [A]

A. FIND THE MIDPOINT OF EACH A.S.K (LOCATED ON P08). DIMENSION [B]

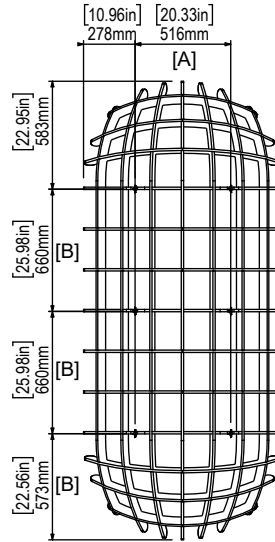

#### STEP 8

AFTER IDENTIFYING EACH CORRESPONDING POINT ON THE CEILING SUBSTRATE, TO THE POINTS MARKED ON STEP 7, DRILL AND ATTACH 1/4"-20 DOUBLE SIDED HANGER BOLT TO SUBSTRATE. REFERENCE DETAIL (SUPPLIED FOR WOOD ANCHORING ONLY). FOR ALL OTHER SUBSTRATES, STUDS/ ANCHORS MUST BE SOURCED BY THE INSTALLER.

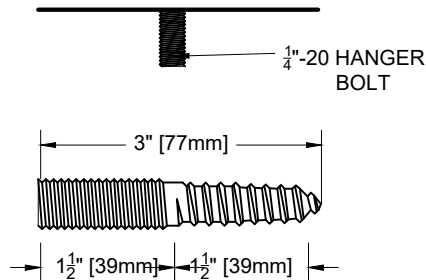

#### STEP 9

A. IDENTIFY THE THREADED END OF THE BARREL AND THE SWAGE END OF THE WIRE.

B. INSERT THE PLAIN END OF THE SUPPLIED WIRE THROUGH THE LARGE THREADED END OF THE BARREL UNTIL THE SWAGE END IS SEATED IN THE BARREL.

C. ATTACH THE THREADED END OF THE BARREL TO 1 / 4"-20 HANGER BOLT.

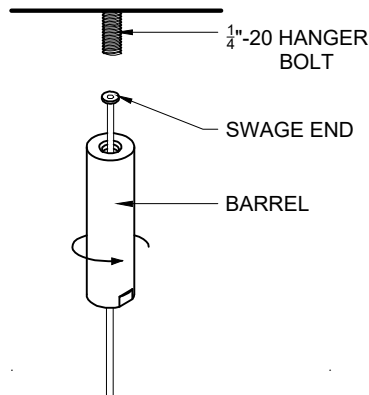

# ZINTRA CLOUDS

## LONG DOME - CONVEX

### INSTALLATION INSTRUCTIONS

#### STEP 10

A. INSERT THE PLAIN END OF THE SUPPLIED WIRE THROUGH ONE SIDE OF THE ADJUSTABLE FASTENERS.

B. LOOP THE WIRE AROUND THE CROSSRUNNER WHERE MARKED.

C. RE-INSERT THE PLAIN END OF THE WIRE INTO THE REMAINING SIDE OF THE ADJUSTABLE FASTENER UNTIL SECURE.

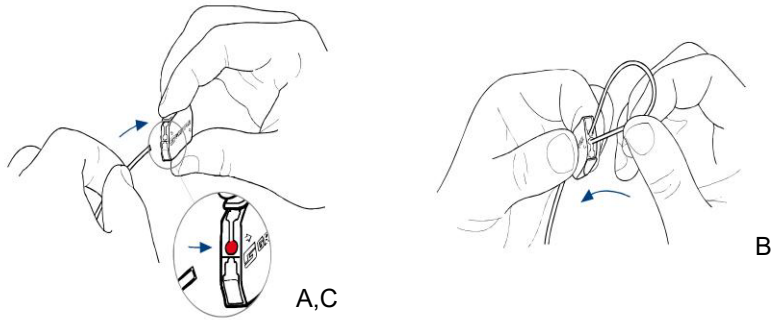

#### STEP 11

ONCE THE HANGING KIT IS PROPERLY SUSPENDED, TRIM THE EXCESS WIRE (IF NECESSARY) WITH WIRE CUTTERS.

**NOTE: WIRE IS INFINITELY ADJUSTABLE BY DEPRESSING TAB ON APPROPRIATE SIDE.**

