

**zintra**  
zintraacoustic.com

**CONNECT**  
**Cirrus**  
INSTALL GUIDE

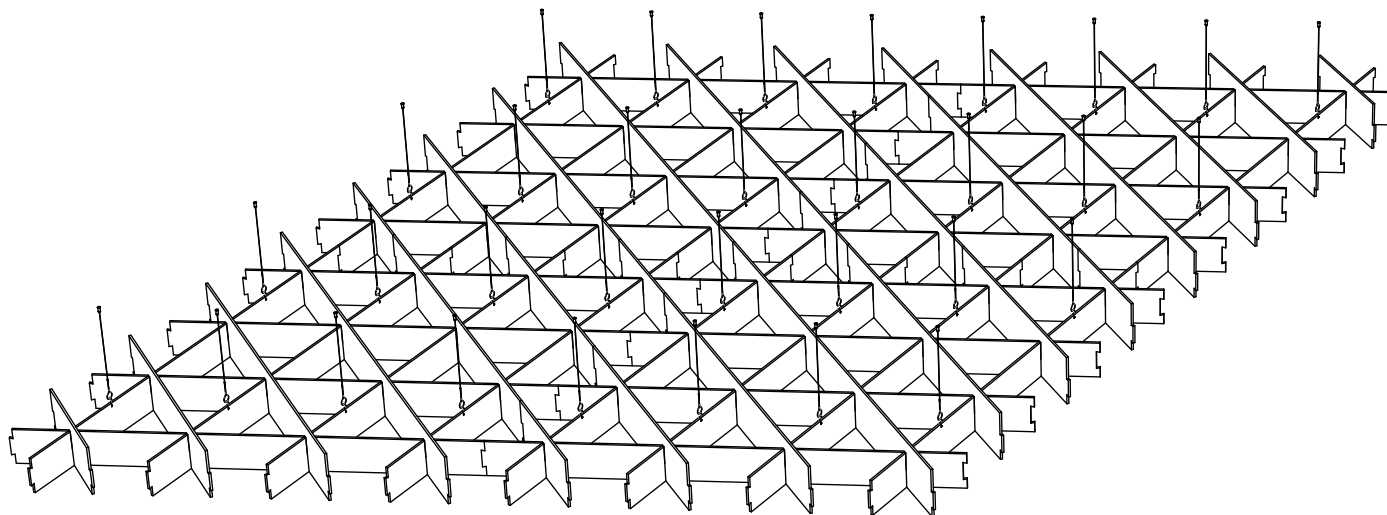

\*NOTE\* Assembly of multiple Systems shown

## CONNECT

### MAKE SITE READY

#### Tips for Installation:

1. We recommend using a laser level for easy marking out and aligning systems
2. Check and count package components to be sure all parts are supplied before beginning
3. We would recommend a rendered print out of the layout to aid install
4. Check for low hanging services and lighting as the system will need to fit around or below these.  
Some site modification may be required on site by installer if obstruction present.

**Note:** *this install guide is a recommendation only. Installer is responsible for site assesment to determine whether install guide is suitable for the application*

#### You Will Need:

1. Measuring tape
2. Pencil
3. Wide field laser level
4. Utility Knife
5. Straight edge/Combination square
6. Ladder or work platform/scaffold
7. Drill and driver
8. Suitable countersunk screws for ceiling type
9. Highly recommend using a panel lifter for easy install



# CONNECT

## ASSEMBLY METHOD - CIRRUS

### STEP 1

1) Interlock blades 1 and 2 as shown below. This will be a loose fit until step 2 is complete.

**\*NOTE\*** keep all male and female dovetail joints on the same side

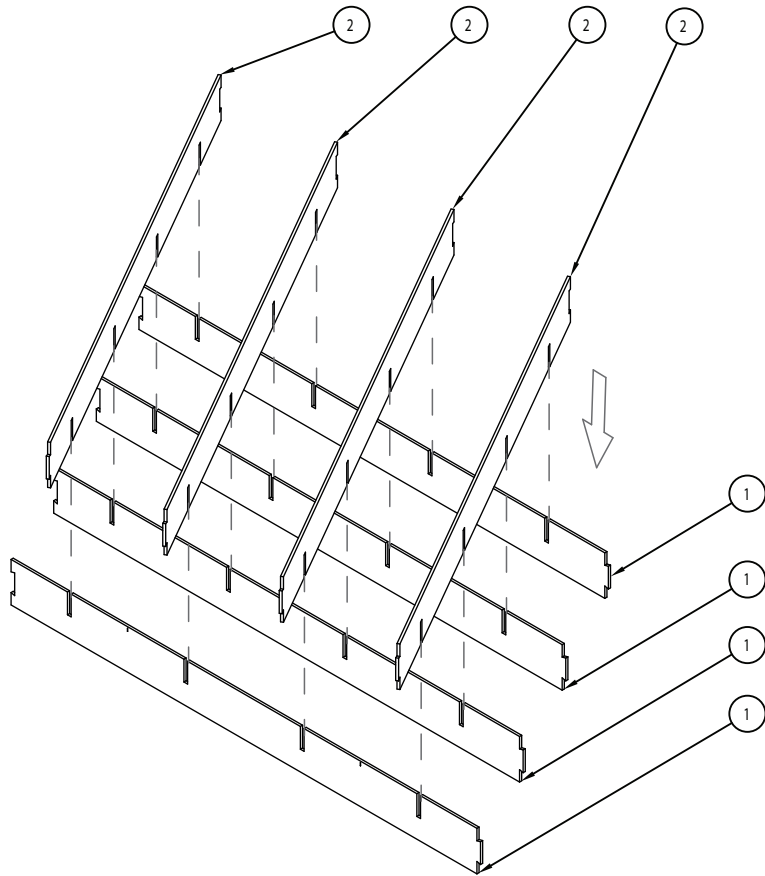

### STEP 2

2) Interlock blades 3-6 into assembly as shown. Slot will slide over intersection of blades 1 and 2. This will lock in any lateral movement.

**\*NOTE\*** again note direction of dovetail joins

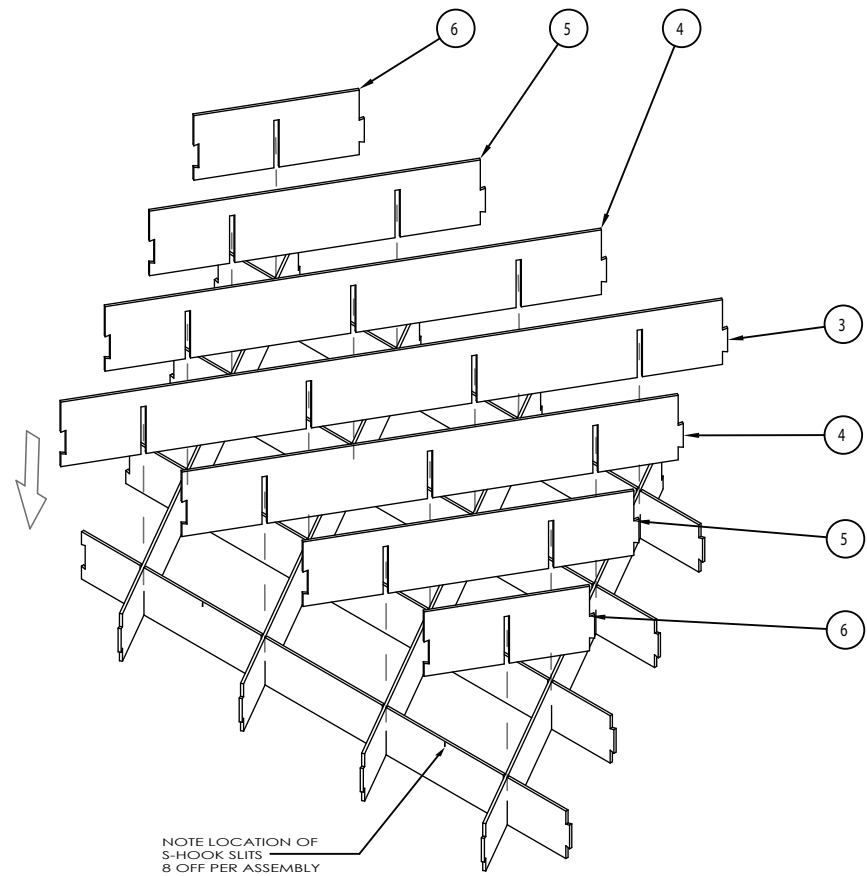

# CONNECT INSTALL METHOD

## STEP 3

3) Mark fixing points on ceiling starting from one corner of room as per layout below. Dimensions include allowance for end caps. If offset from wall is specified, add this distance to first rows below. We would recommend leaving an offset/express gap of .25"-.75" [10-20mm] to minimise the impact of any bowing in the wall. *This is not included in measurements below.*

Continue with this until you reach terminating walls or assembly end.

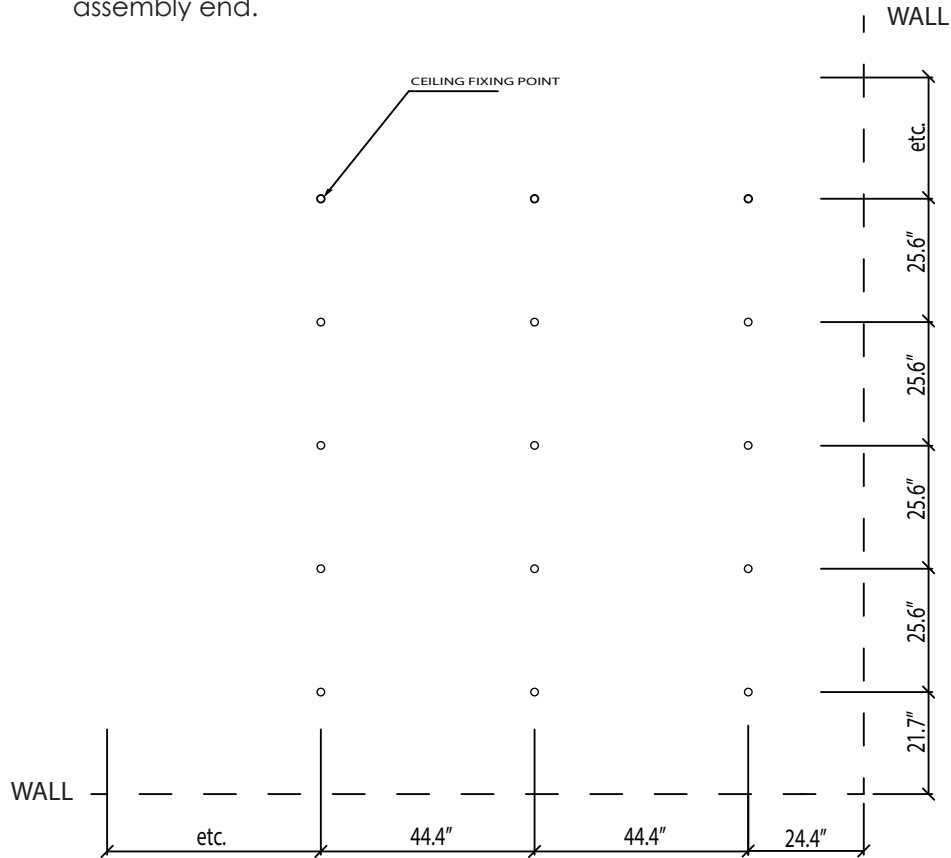

**TIP: A wide field laser level will help with marking out**

## STEP 4

3) Install the 1/4"-20 hanger bolts to the substrate. The supplied hanger bolts are intended for use in wood only. For other substrates the installer will need to source the appropriate hardware.

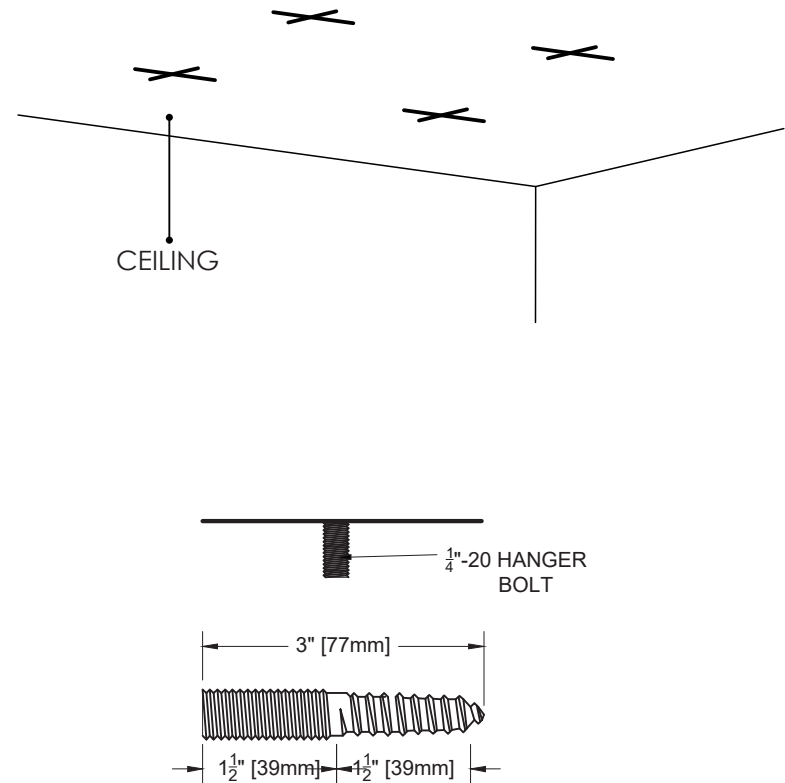

# CONNECT INSTALL METHOD

## STEP 5

Identify the threaded end of the barrel and the swage end of the cable. Insert the plain end of the supplied wire through the large threaded end of the barrel until it is fully seated. Attach the threaded end of the barrel to the 1/4"-20 hanger bolt.

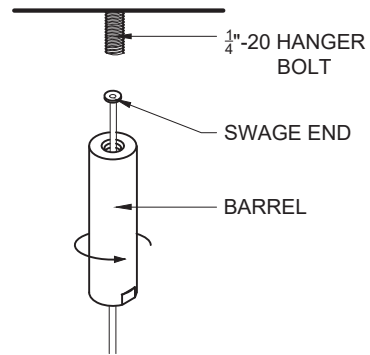

## STEP 6

Insert the plain end of the cable through one side of the adjustable fastener. Re-insert the plain end of the cable through the remaining side of the adjustable fastener to create a loop in the cable.

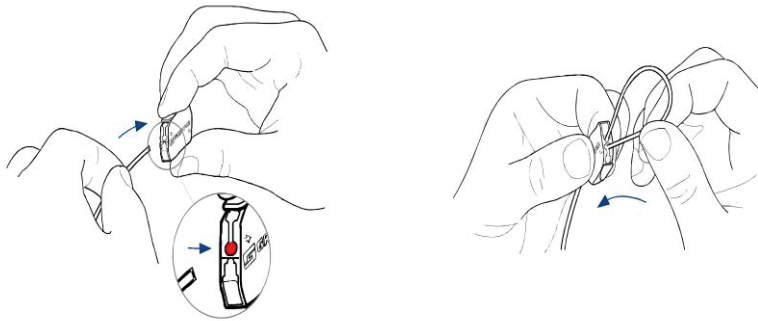

## STEP 7

7a) Fit end caps to dovetail joints that will be exposed or against walls. All other joints, leave open to connect sets together.

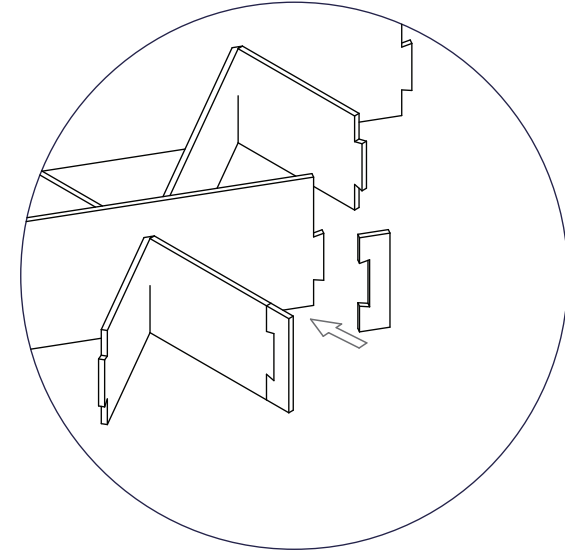

## OR

7b) If site conditions would better suit no end caps, the dovetail joints can be trimmed off the ends of the zintra by following cutting process in step 11

# CONNECT INSTALL METHOD

## STEP 8

8) Fit S-Hooks into precut slits in zintra profiles

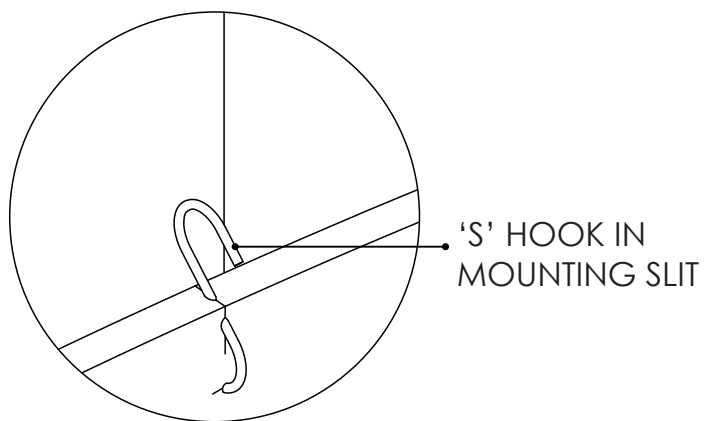

## STEP 9

9) Suspend assembly by looping 'S' hooks through look created in wire

First assembly to start in corner of room as per below.

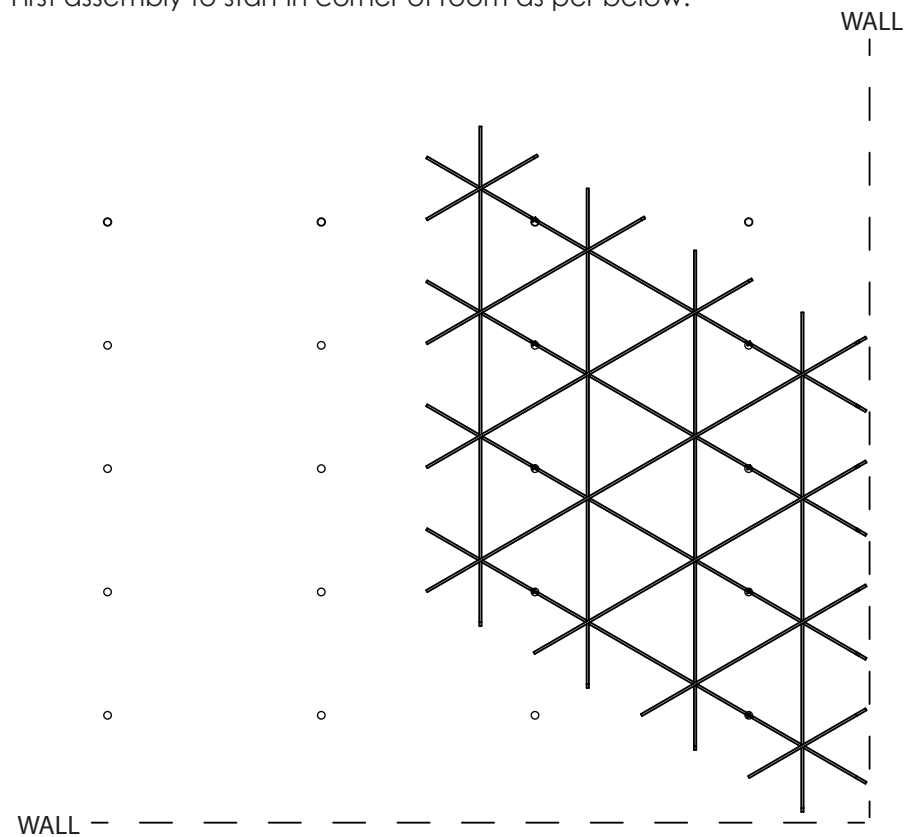

**TIP: We recommend a panel lifter for lifting assembly safely and accurately**

# CONNECT

## ASSEMBLY METHOD - CIRRUS 1A

### STEP 10

10) Measure distance between set 1 and the wall. Be sure to measure both ends of the system to be sure walls are square to assembly. We would recommend leaving a gap of .25-.75" [10-20mm] to minimise the impact of any bowing in the wall.

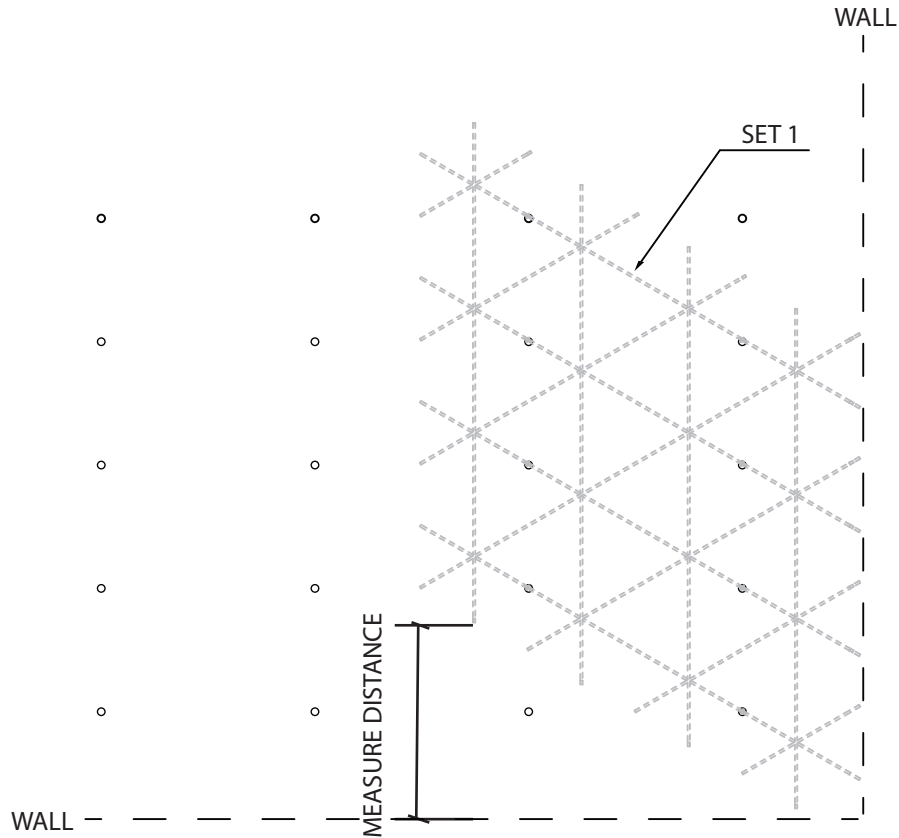

**\*NOTE\*** Always measure from shoulders of dovetail joint.

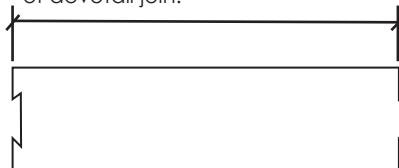

### STEP 11

11) Assemble set 2 and mark where to be cut. Using a sharp blade and square, cut each each piece to length based on measurements from step 10,. A downward angle and pressure on the blade will make cutting easier.

**\*NOTE\*** note direction of dovetail joins  
The rest of the set will be used later - do not throw away

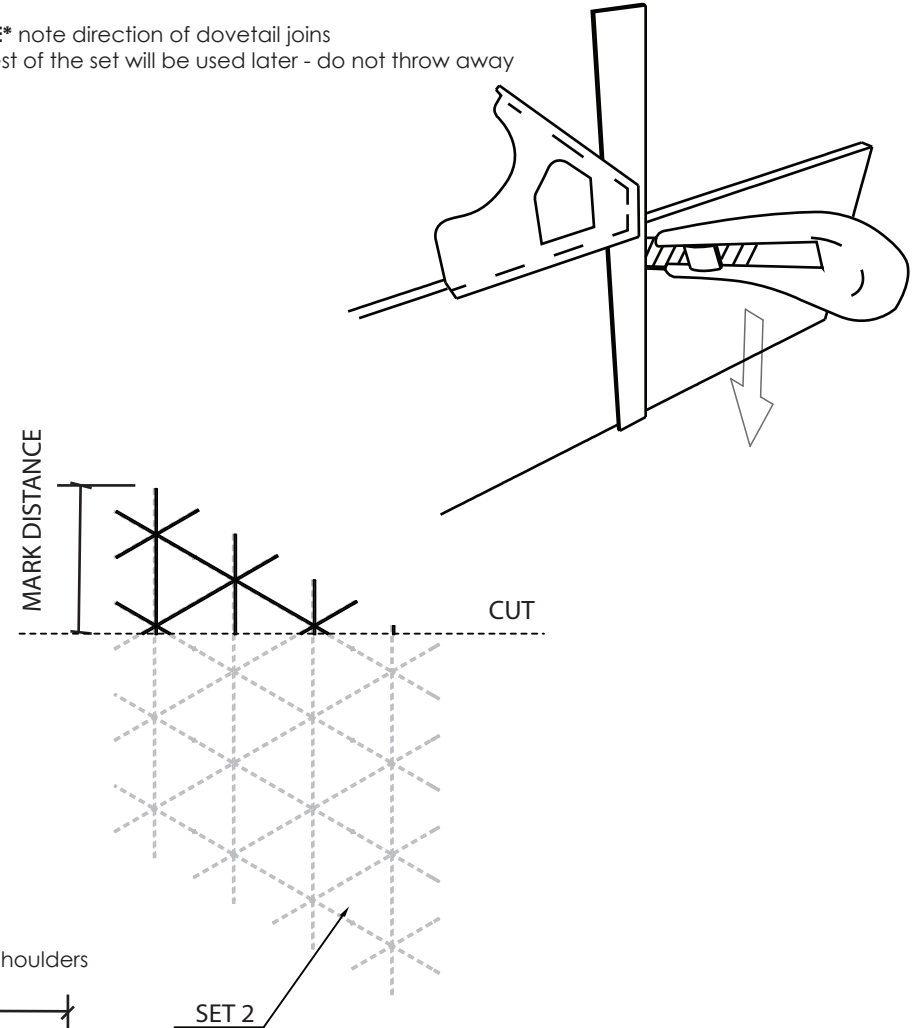

# CONNECT INSTALL METHOD

## STEP 12

12) Suspend set 2 by looping 'S' hooks through loop created in wire

Fit assembly to adjacent system installed in step 9.  
Locate dovetail joins and press fit together

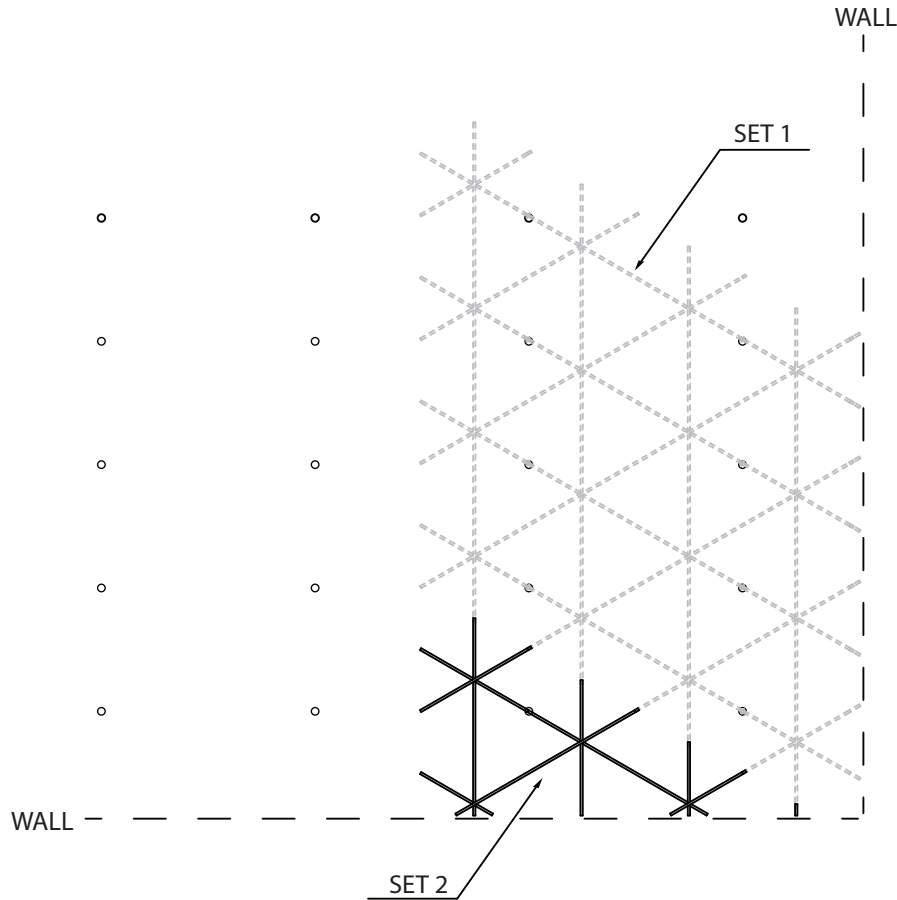

## STEP 13

13) Suspend next full assembly by looping 'S' hooks through loop created in wire

Fit assembly to adjacent system installed in step 9.  
Locate dovetail joins and press fit together

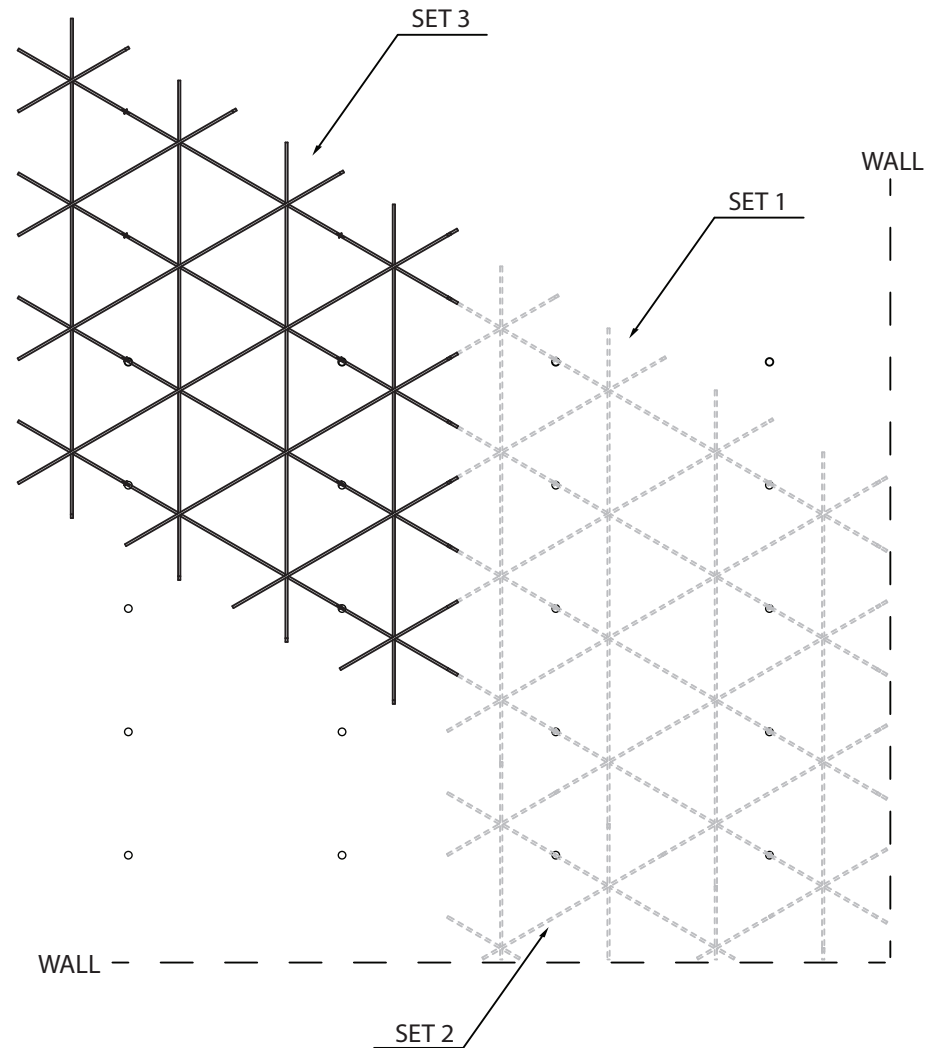



# CONNECT INSTALL METHOD

## STEP 14

14) measure distance from set 3 to the wall. Be sure to measure both ends of the system to be sure walls are square to assembly. We would recommend leaving a gap of .25-.75" [10-20mm] to minimise the impact of any bowing in the wall.

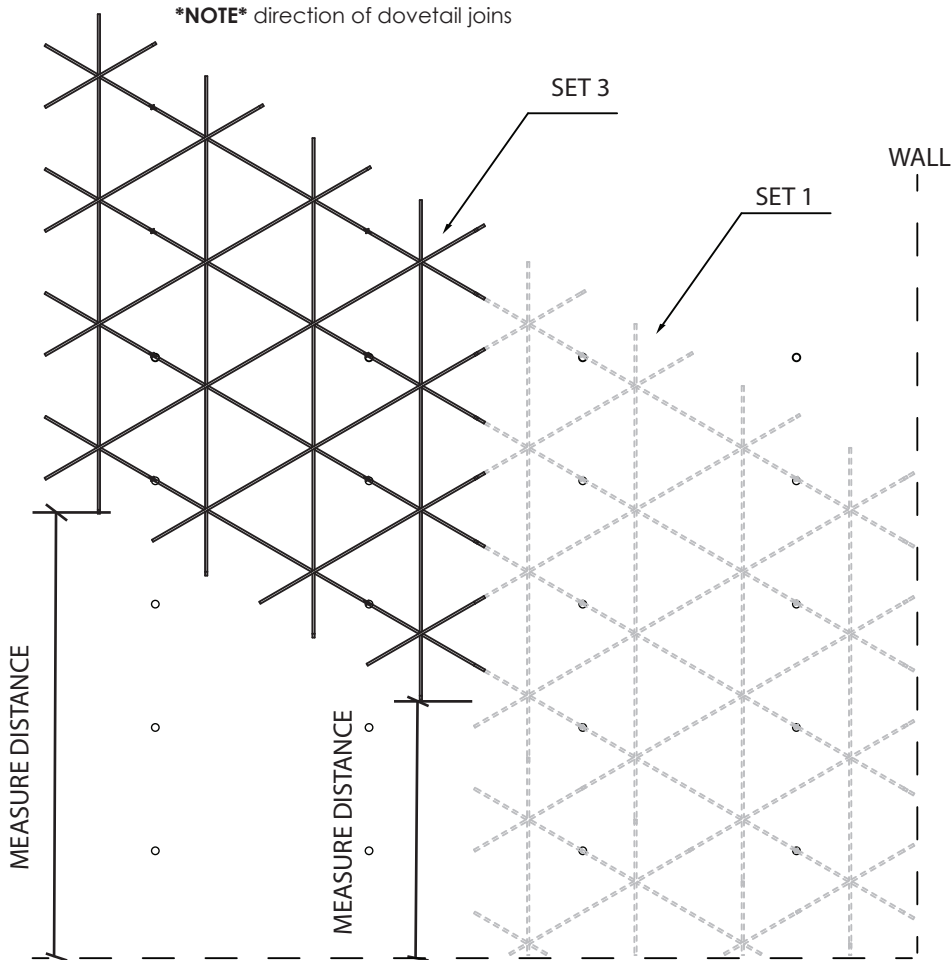

## STEP 15

15) mark as per measurements from step 14 and cut Set 4 to size. Again do not throw away offcut, this can be used elsewhere

**\*NOTE\*** note direction of dovetail joints

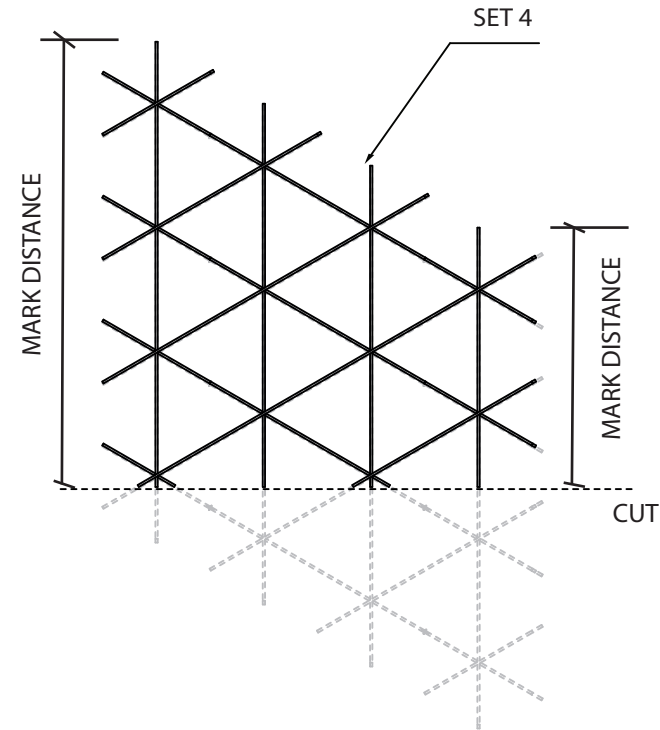

**\*NOTE\*** Always measure from shoulders of dovetail joint.

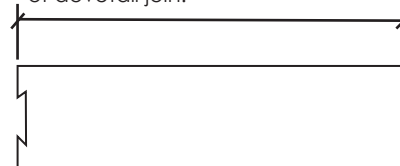

# CONNECT

## INSTALL METHOD

### STEP 16

16) Suspend assembly by looping 'S' hooks through look created in wire. Locate dovetail joints and press fit together

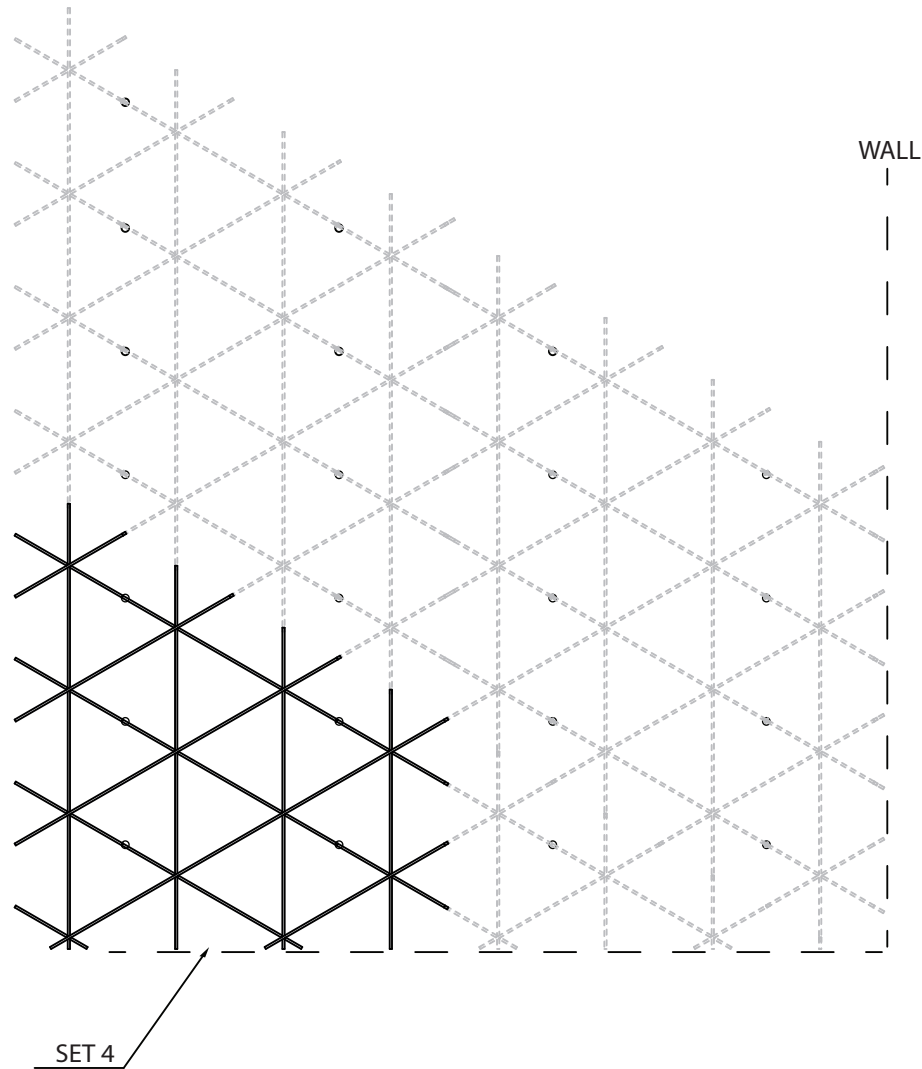

### STEP 17

17) Repeat steps 9 - 16 and install in both directions across room until meeting opposite walls or terminating system

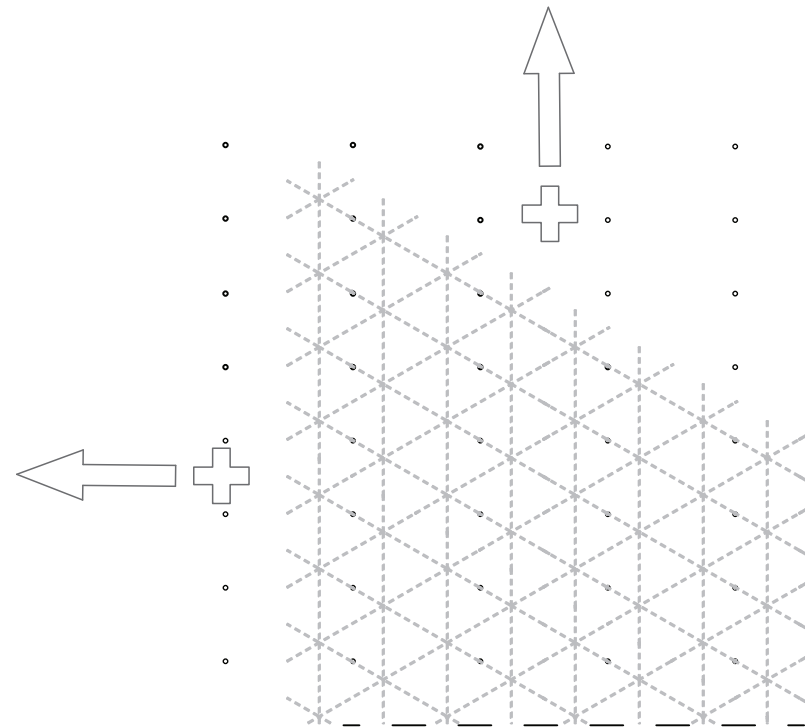

# CONNECT INSTALL METHOD

## STEP 18

18) Measure distance from end of installed system to terminating wall (or terminating location if not butting up against a wall). Be sure to measure both ends of the system to be sure walls are square to assembly. We would recommend leaving a gap of .25-.75" [10-20mm] to minimise the impact of any bowing in the wall.

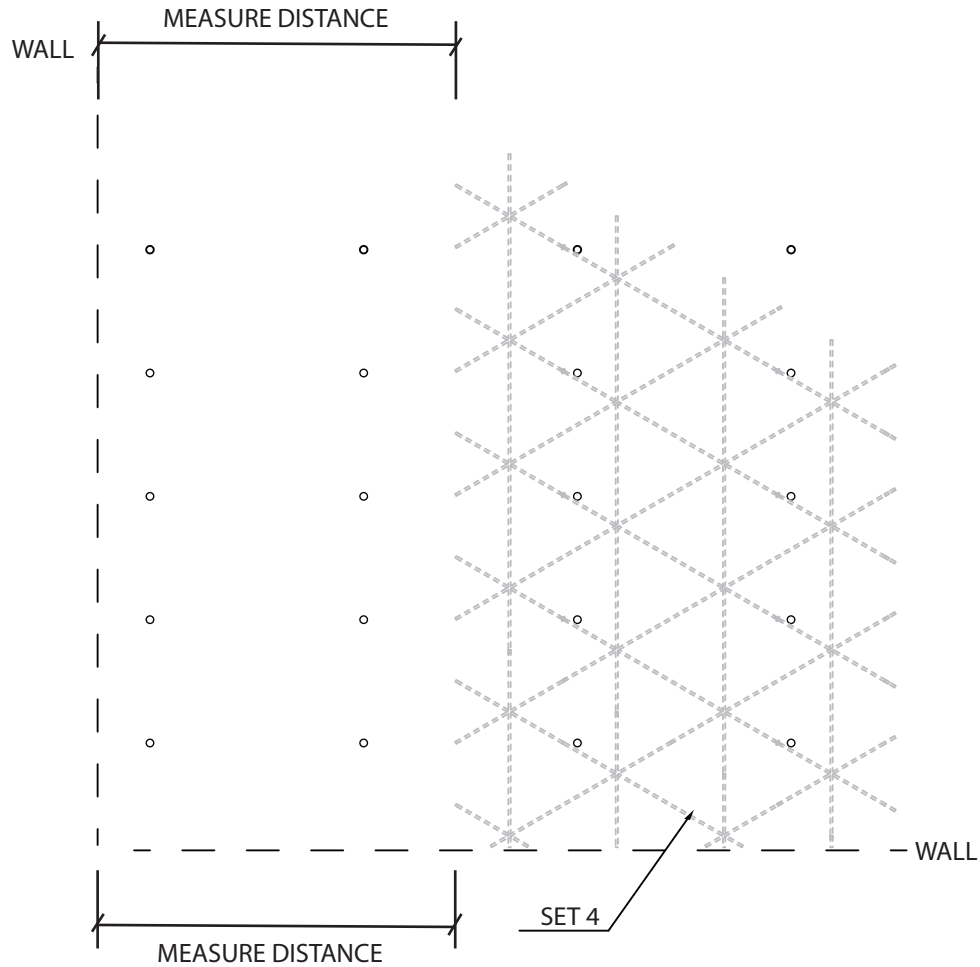

## STEP 19

19) Mark distance on terminating assembly top edge. A laser will help to keep markings in a straight line. cut as per step 11

**\*NOTE\*** measure and mark from shoulders of dovetail

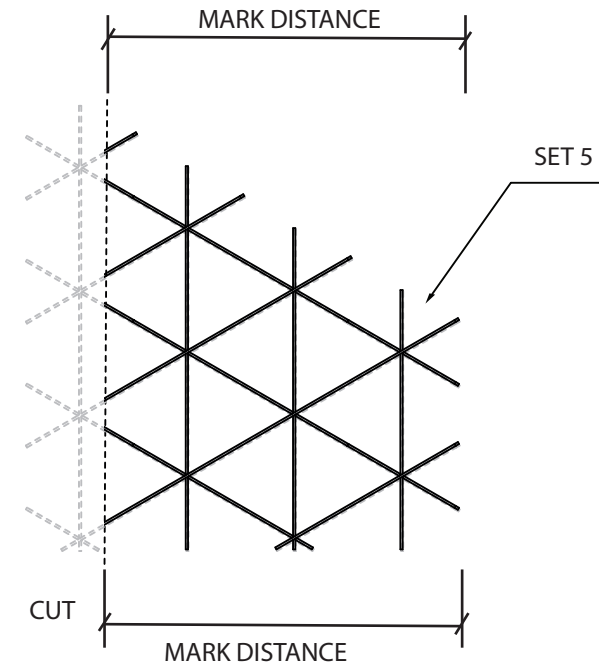

**\*NOTE\*** Always measure from shoulders of dovetail join.

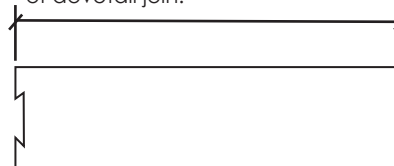

# CONNECT INSTALL METHOD

## STEP 20

20) Suspend set 5 by looping 'S' hooks through swaged wire.

Fit assembly to adjacent system installed in step 9.  
Locate dovetail joins and press fit together

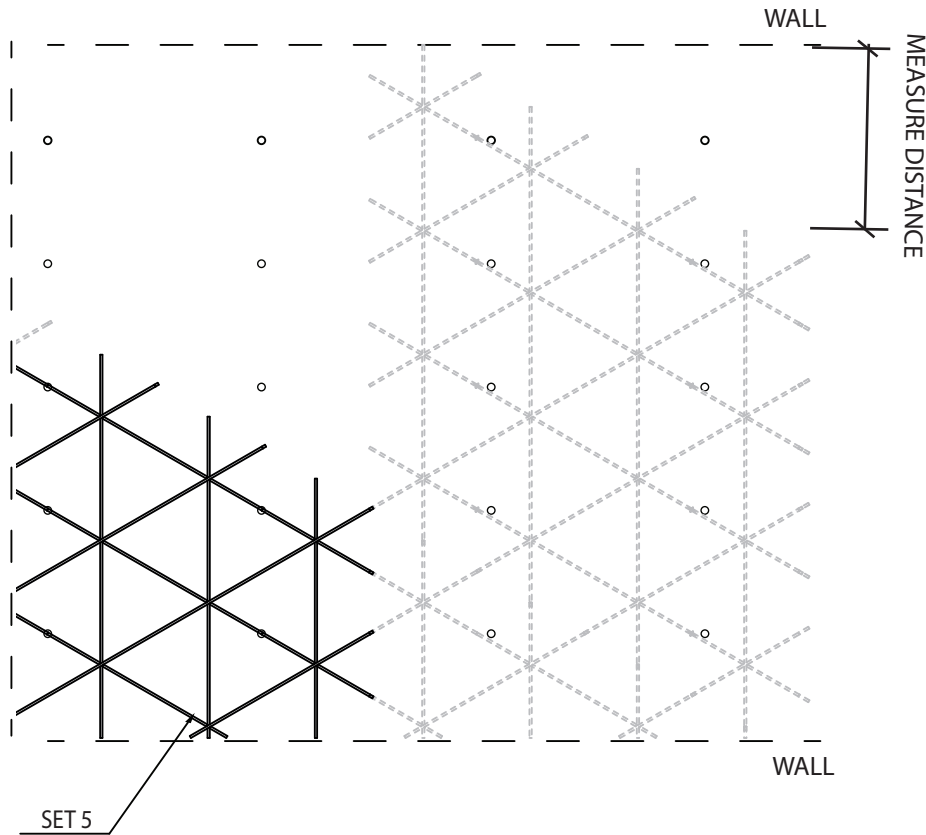

## STEP 21

21) Suspend corner terminating system.

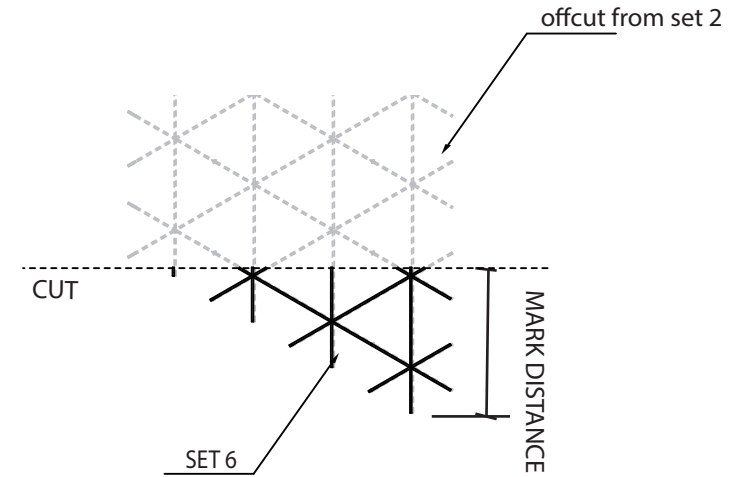

**\*NOTE\*** Always measure from shoulders of dovetail join.

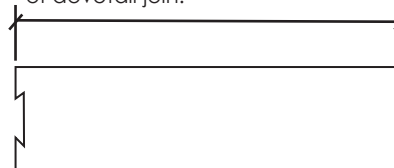

# CONNECT INSTALL METHOD

## STEP 22

22) Measure distance from end of installed system to terminating wall (or terminating location if not butting up against a wall). Be sure to measure both ends of the system to be sure walls are square to assembly. We would recommend leaving an express gap of .25"-.75" [10-20mm] to minimize the impact of any bowing in the wall.

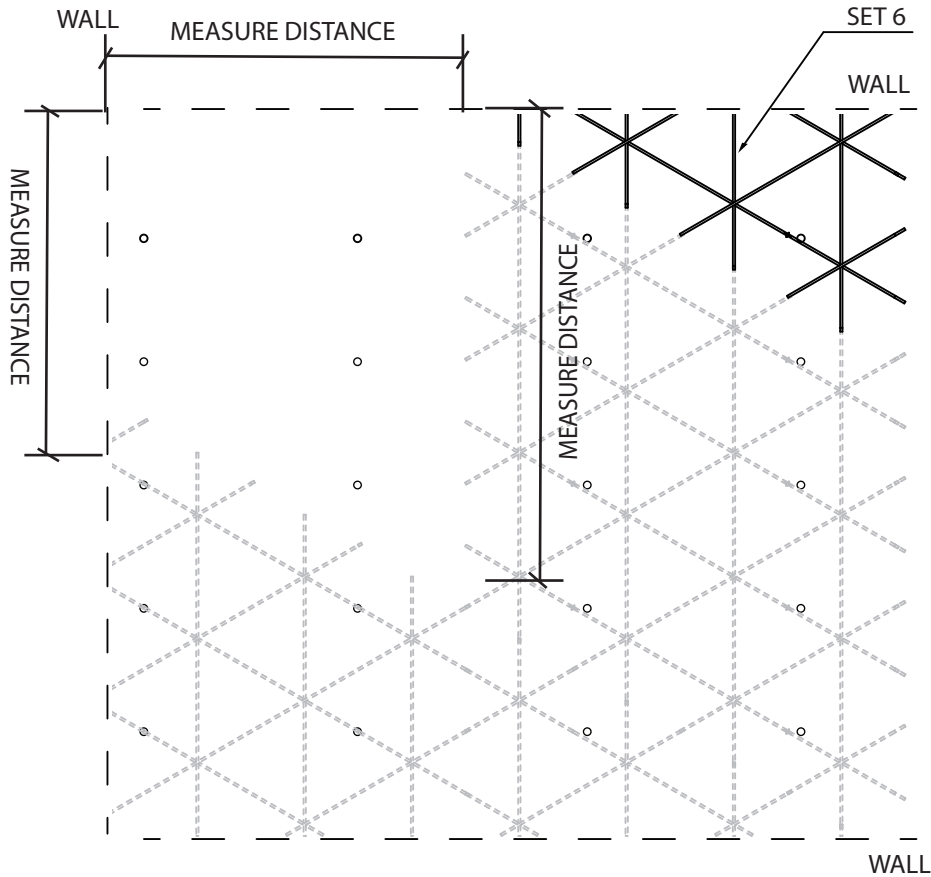

## STEP 23

23) Mark distance on terminating assembly top edge. A laser will help to keep markings in a straight line.

Cut to size as per step 11.

**\*NOTE\*** Mark and measure from the shoulders of dovetail

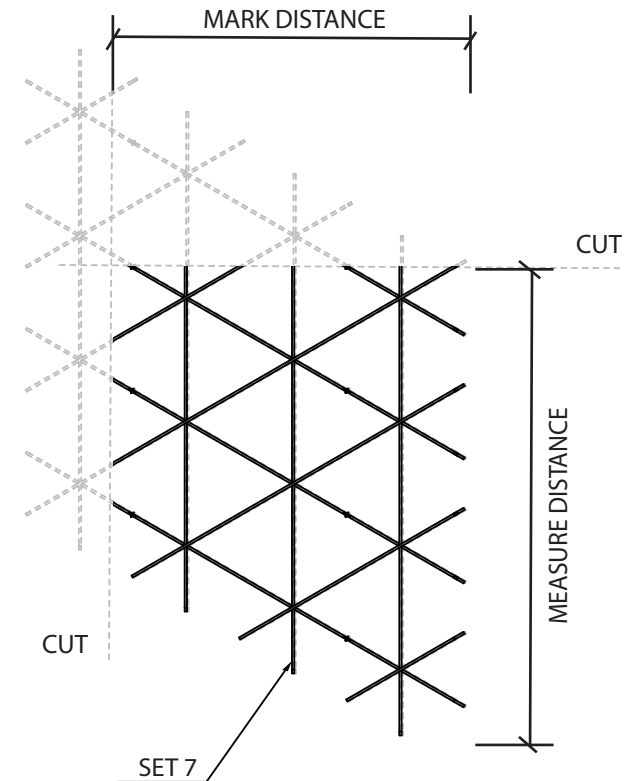

**\*NOTE\*** Always measure from shoulders of dovetail join.

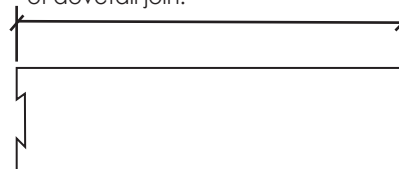

# CONNECT

## INSTALL METHOD

### STEP 24

24) Suspend middle terminating system

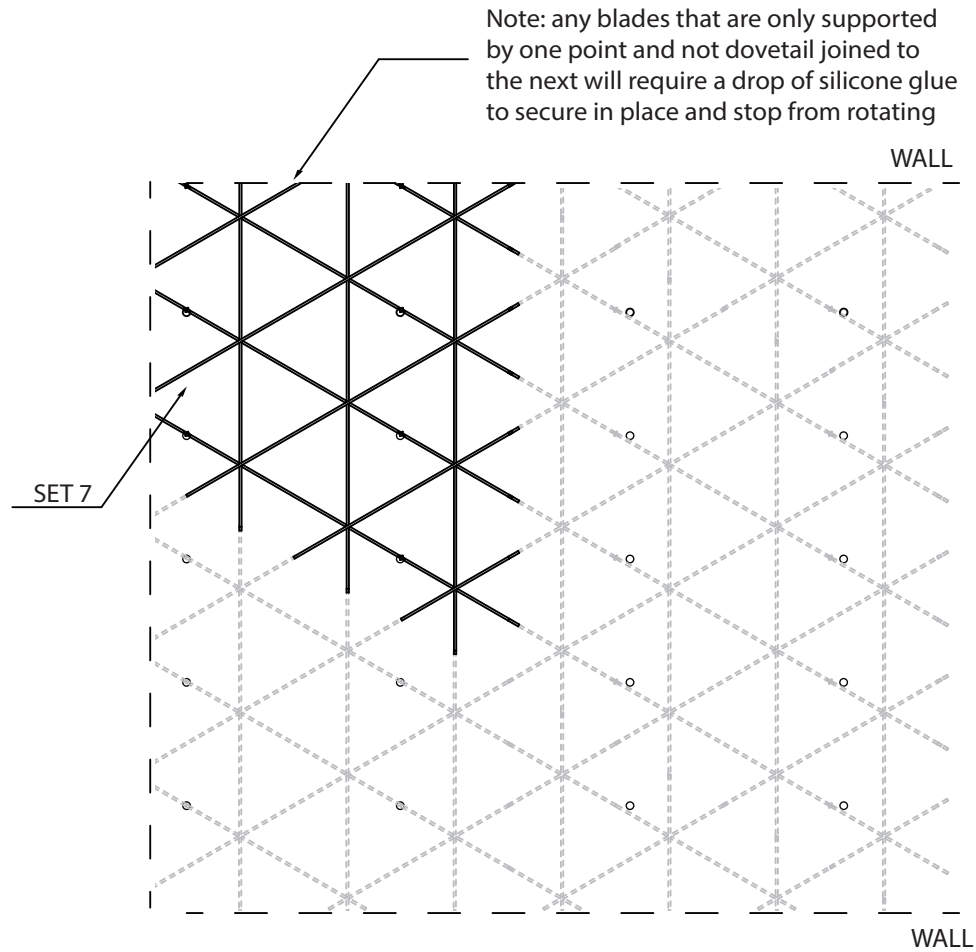

# CONNECT

## INSTALL METHOD

### STEP 26

26) Re-adjust wire length as explained in STEP 6 until entire assembly hangs level. Trim excess wire for a neat finish.

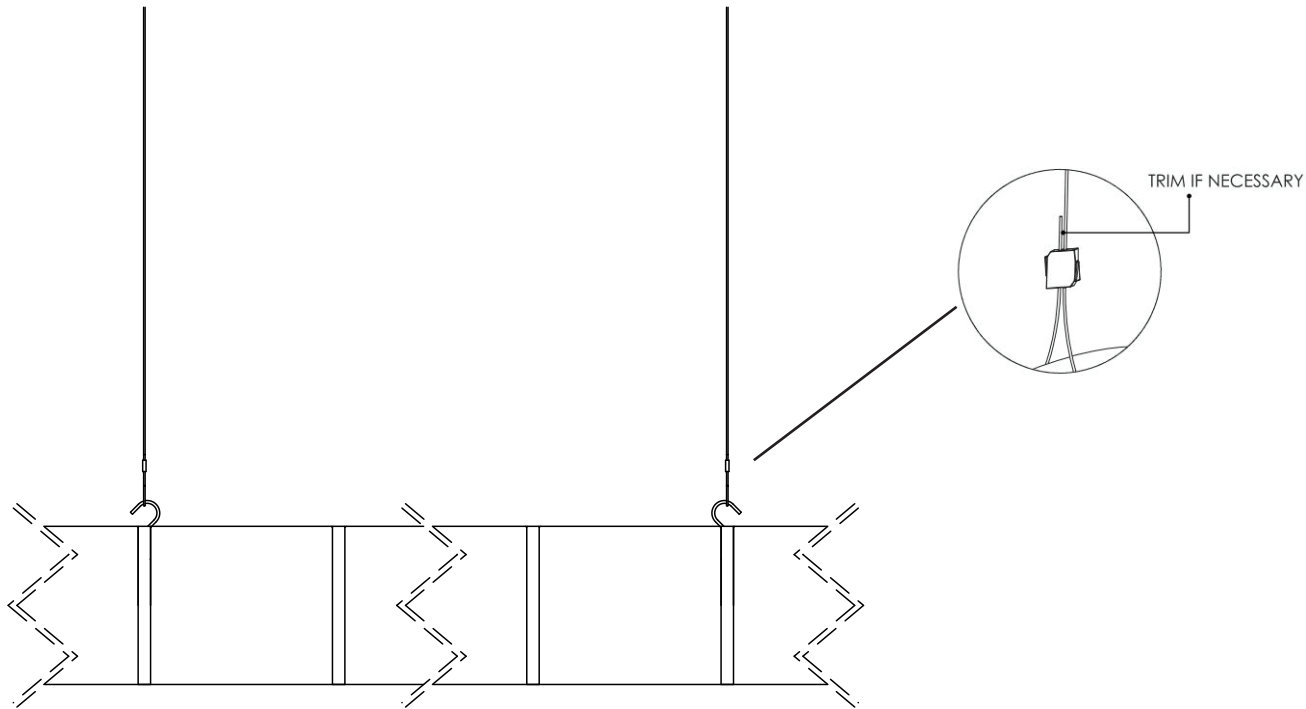

**CONNECT**  
INSTALL COMPLETE

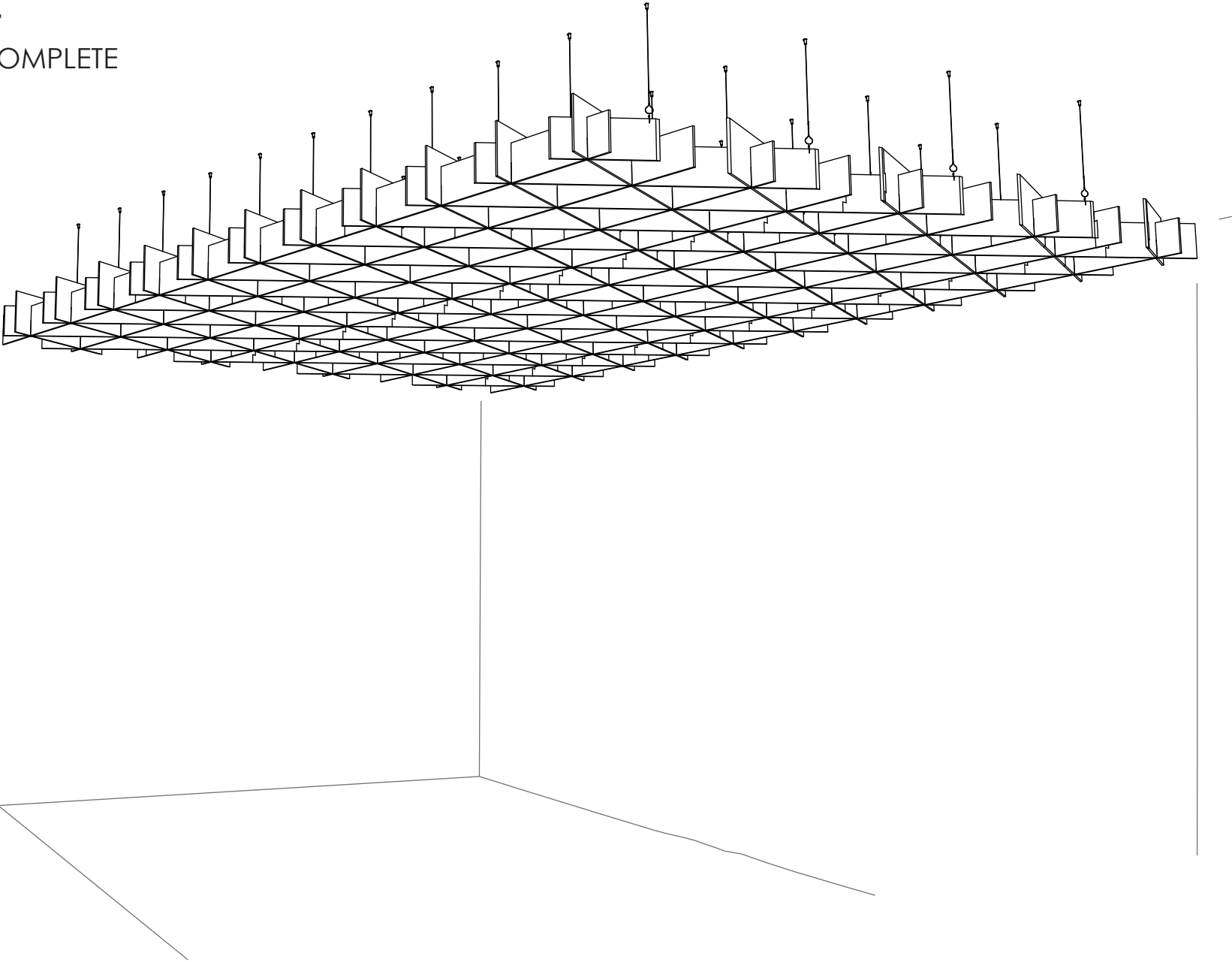



**CONNECT -  
CIRRUS**  
PARTS (PER SYSTEM)



**ADJUSTABLE FASTENER**  
CIRRUS - 8 OFF

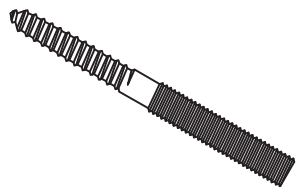

**HANGER BOLT**  
CIRRUS - 8 OFF

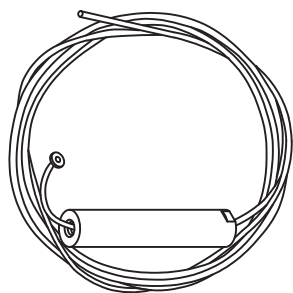

**CABLE WITH  
BARREL FIXING**  
CIRRUS - 8 OFF



**'S' HOOK**  
CIRRUS - 8 OFF

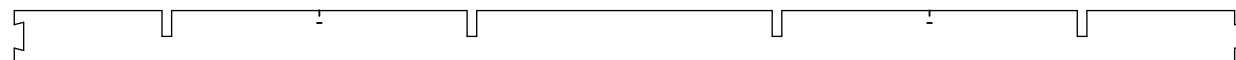

**PROFILE 1**  
4 OFF

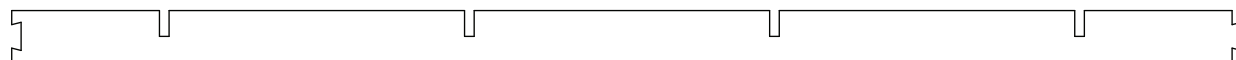

**PROFILE 2**  
4 OFF



**PROFILE 3**  
1 OFF

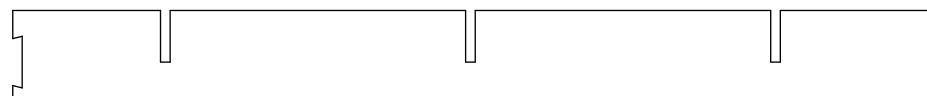

**PROFILE 4**  
2 OFF



**PROFILE 5**  
2 OFF

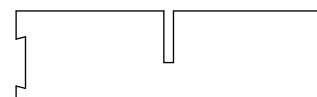

**PROFILE 6**  
2 OFF



**SHORT CAP**  
8 OFF



**TALL CAP**  
7 OFF