

# ZINTRA

## BOLT BAFFLE SYSTEM (V2)

### INSTALLATION INSTRUCTIONS

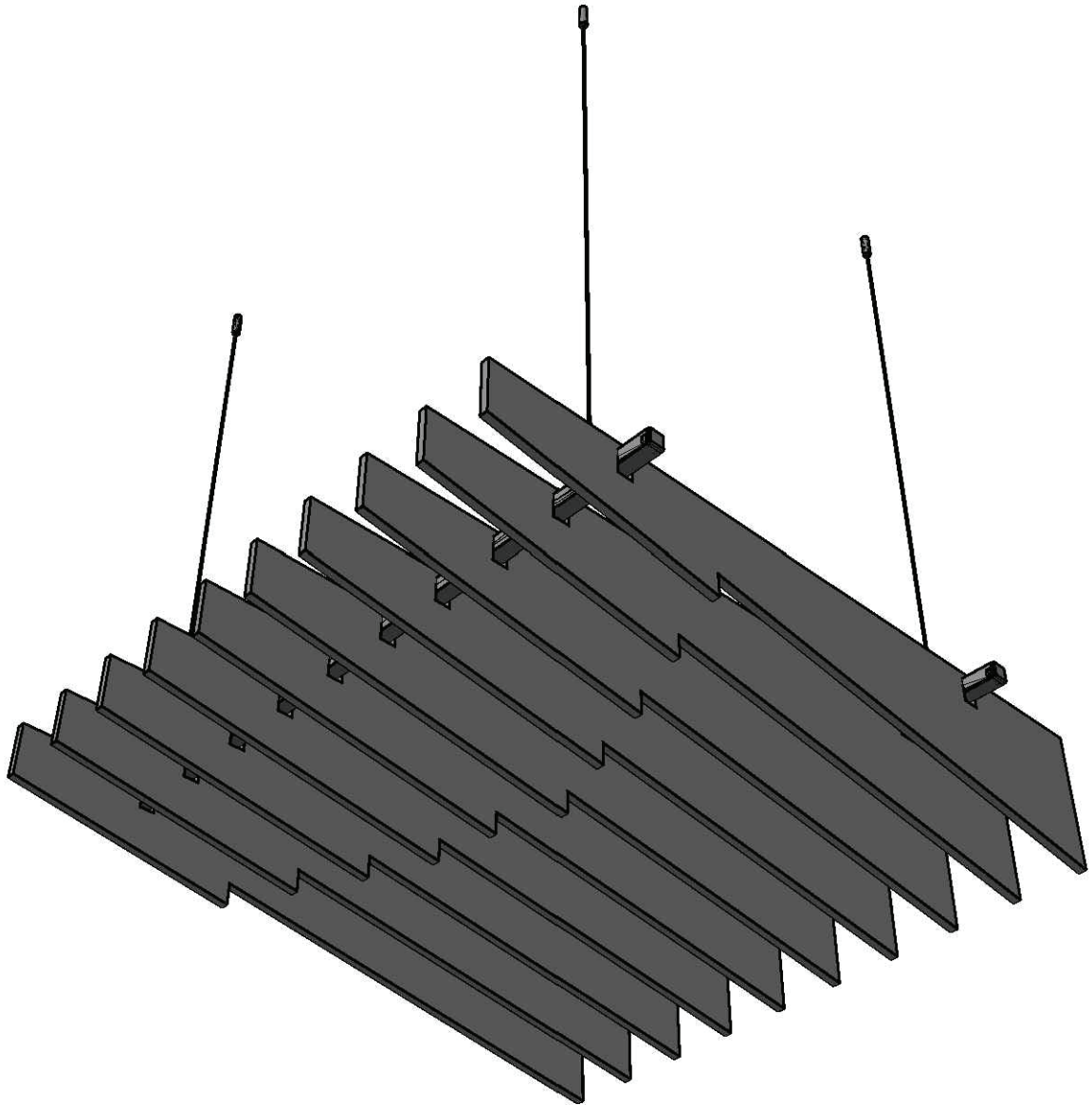

## PARTS AND HARDWARE

(4) CABLE WITH SWAGE END, AND BARREL



(4) 1/4" - 20 HANGER BOLT (FOR USE WITH WOOD SUBSTRATE ONLY)



(4) ADJUSTABLE FASTENER



(4) END CAP



(2) ZINTRA CONNECTOR

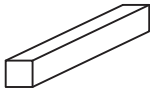

(2) CROSSRUNNER WITH NOTCHES

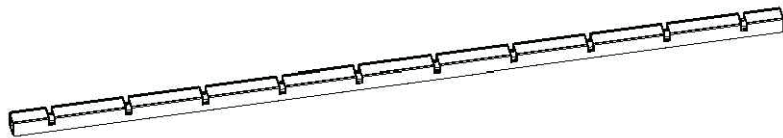

(10) ZINTRA BLADES MARKED 1-6

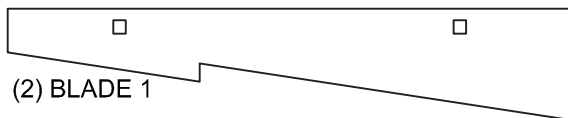

(2) BLADE 1

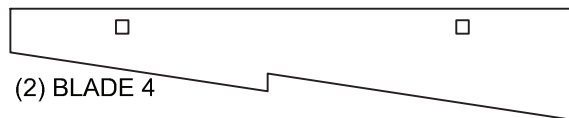

(2) BLADE 4

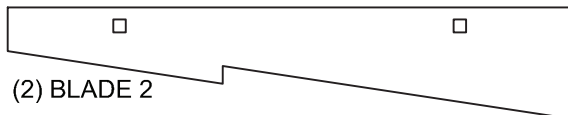

(2) BLADE 2

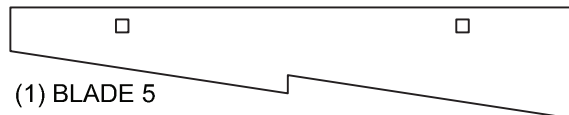

(1) BLADE 5

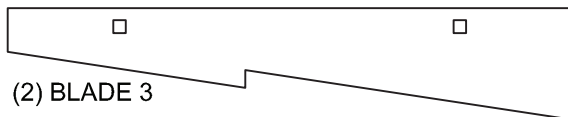

(2) BLADE 3

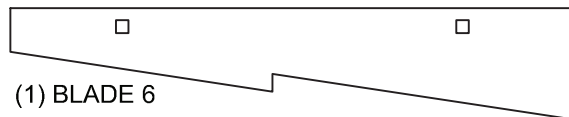

(1) BLADE 6

## BAFFLE ASSEMBLY

### STEP 1

BEGIN WITH FIRST BAFFLE #1

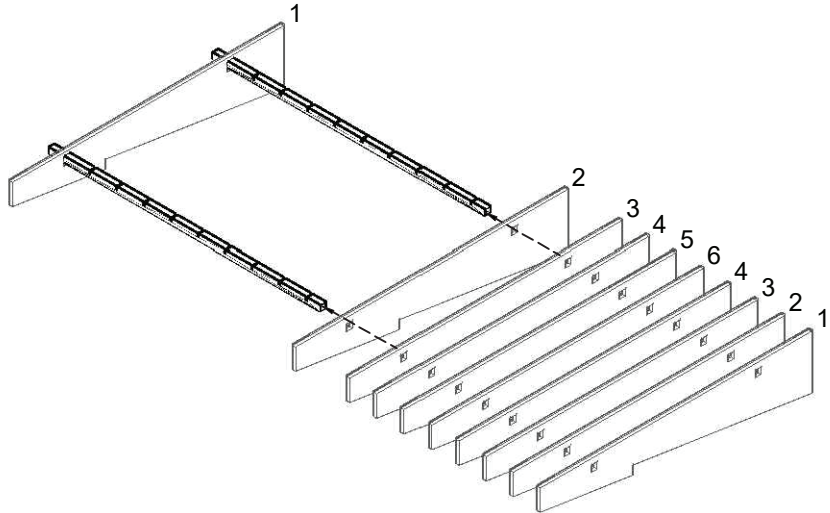

### STEP 2

A. INSERT EACH OF THE CROSSRUNNERS INTO THE CORRESPONDING PRE-CUT RECTANGULAR HOLES IN THE BAFFLE.

B. WITH THE BAFFLE ALIGNED-PRESS BAFFLE DOWN INTO NOTCH UNTIL FULLY SEATED.

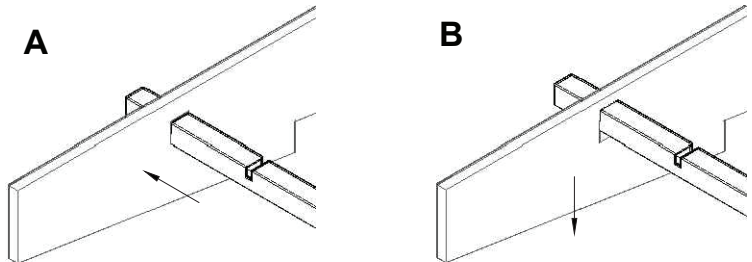

### STEP 3

REPEAT STEPS 1-2 FOR EACH SEQUENTIAL BAFFLE UNTIL THE ENTIRE ASSEMBLY HAS BEEN COMPLETED.

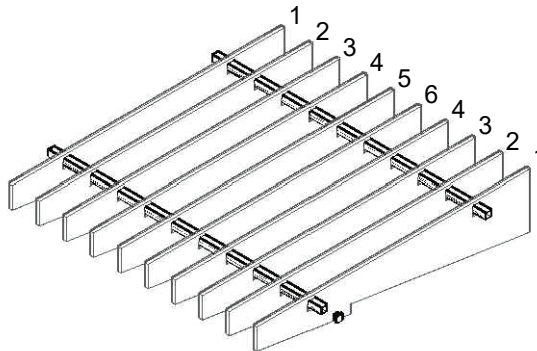

## INSTALLATION INSTRUCTIONS

### STEP 4

A. FIND THE MIDPOINT BETWEEN BAFFLE #1 AND BAFFLE #2. MARK THE TOP SIDE OF THE CROSSRUNNER AT THIS POINT (REFER TO X ON THE DETAIL).

B. ON THE OPPOSITE END OF THE SAME CROSSRUNNER AND MARK THE MIDPOINT BETWEEN THE LAST BAFFLE AND THE SECOND TO LAST BAFFLE.

C. REPEAT THIS PROCESS FOR EACH CROSSRUNNER.

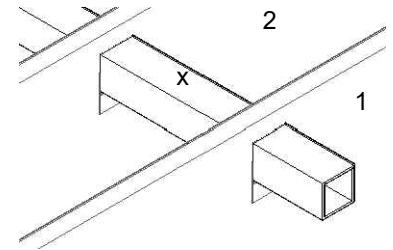
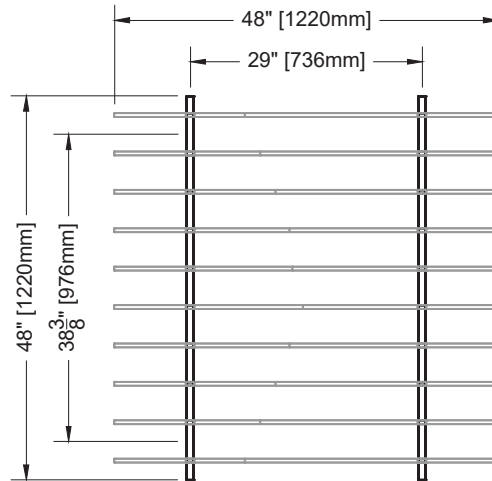

### STEP 5

AFTER IDENTIFYING EACH CORRESPONDING POINT ON THE CEILING SUBSTRATE, TO THE POINTS MARKED ON STEP 4, DRILL AND ATTACH 1/4"-20 DOUBLE SIDED HANGER BOLT TO SUBSTRATE. REFERENCE DETAIL (SUPPLIED FOR WOOD ANCHORING ONLY). FOR ALL OTHER SUBSTRATES, STUDS/ ANCHORS MUST BE SOURCED BY THE INSTALLER.

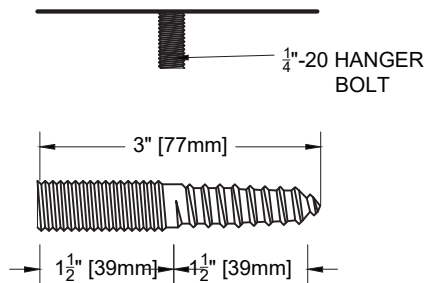

### STEP 6

A. IDENTIFY THE THREADED END OF THE BARREL AND THE SWAGE END OF THE WIRE.

B. INSERT THE PLAIN END OF THE SUPPLIED WIRE THROUGH THE LARGE THREADED END OF THE BARREL UNTIL THE SWAGE END IS SEATED IN THE BARREL.

C. ATTACH THE THREADED END OF THE BARREL TO 1 / 4"-20 HANGER BOLT.

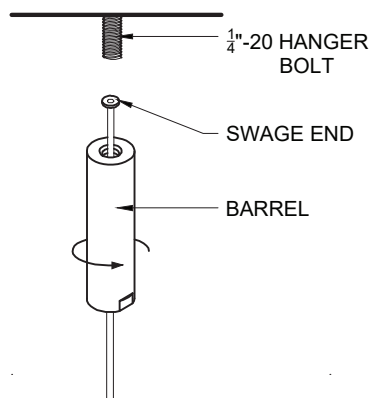

# ZINTRA BOLT BAFFLE SYSTEM (V2) INSTALLATION INSTRUCTIONS

## STEP 7

A. INSERT THE PLAIN END OF THE SUPPLIED WIRE THROUGH ONE SIDE OF THE ADJUSTABLE FASTENERS.

B. LOOP THE WIRE AROUND THE CROSSRUNNER WHERE MARKED.

C. RE-INSERT THE PLAIN END OF THE WIRE INTO THE REMAINING SIDE OF THE ADJUSTABLE FASTENER UNTIL SECURE.

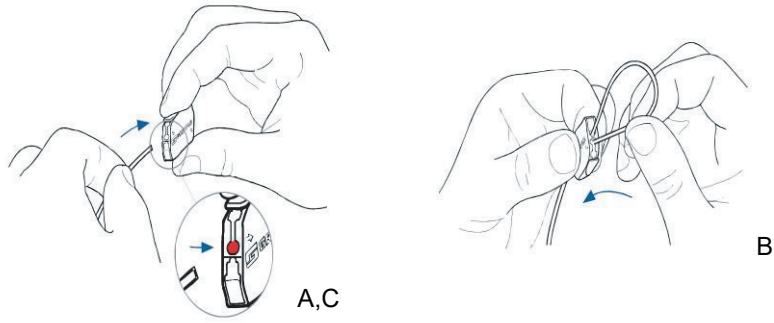

## STEP 8

ONCE THE BAFFLE IS PROPERLY SUSPENDED, TRIM THE EXCESS WIRE (IF NECESSARY) WITH WIRE CUTTERS.

**NOTE: WIRE IS INFINITELY ADJUSTABLE BY DEPRESSING TAB ON APPROPRIATE SIDE.**

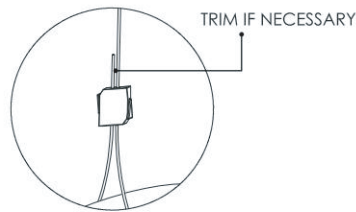

## STEP 9

A. CAP THE END OF THE SUSPENSION RODS BY PRESSING THE SUPPLIED PVC CAPS UNTIL SECURE.

B. TO CONNECT MULTIPLE BAFFLE SYSTEMS TOGETHER USE THE SUPPLIED ZINTRA CONNECTORS. INSERT ONE OF THEM HALF WAY INTO THE CROSSRUNNER, AND THE OTHER HALF INTO THE ADJACENT CROSSRUNNER. ADJUST AS NEEDED FOR ALIGNMENT.

