

ZINTRA

INDIVIDUAL CUP HOOK BAFFLE INSTALLATION INSTRUCTIONS

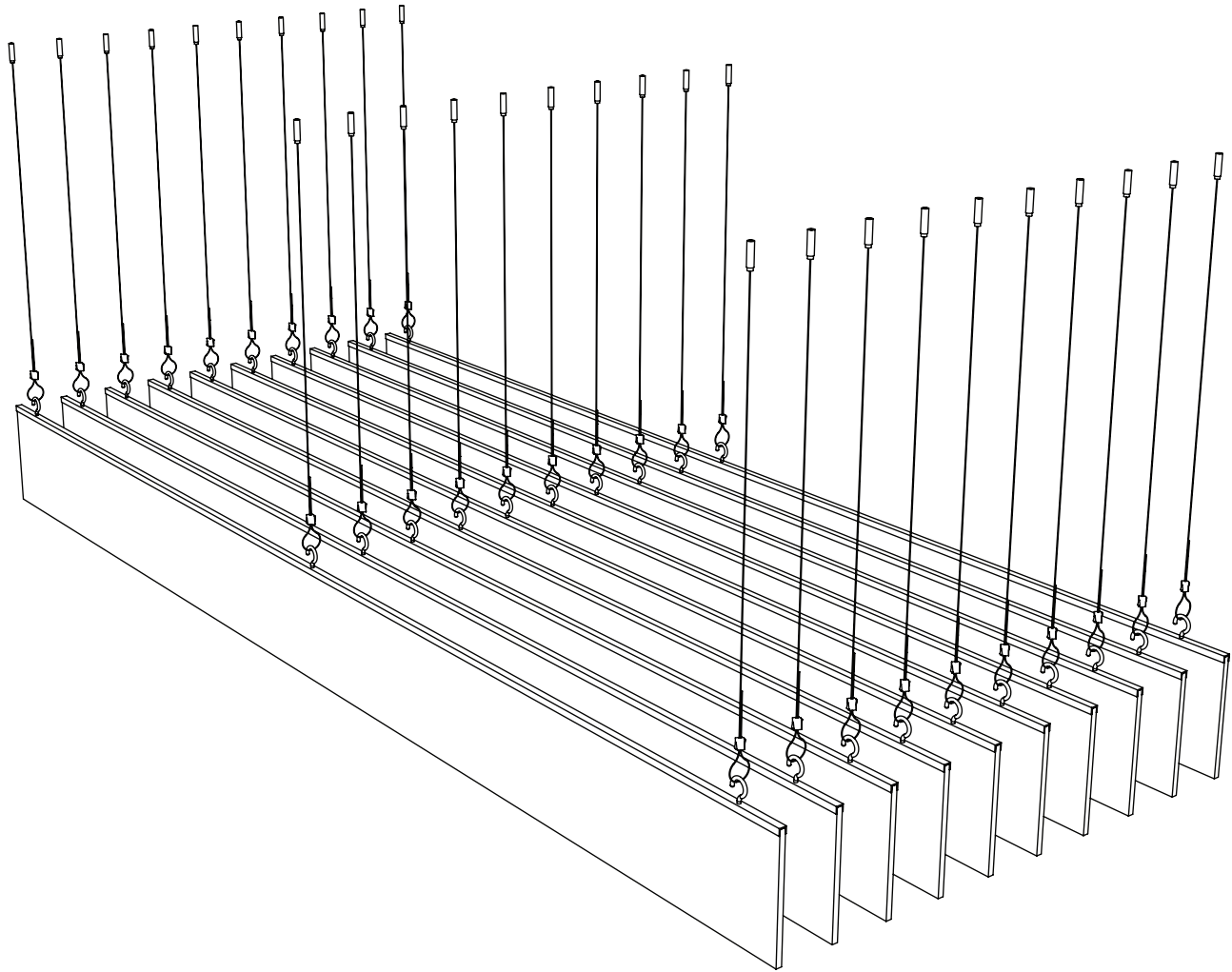



ZINTRA

INDIVIDUAL CUP HOOK BAFFLE

INSTALLATION INSTRUCTIONS

PARTS AND HARDWARE

(3 PER BAFFLE) CABLES WITH SWAGED END, AND BARREL



(3 PER BAFFLE) 1/4" - 20 HANGER BOLT (FOR USE WITH WOOD SUBSTRATE ONLY)

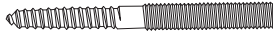

(3 PER BAFFLE) ADJUSTABLE FASTENER



(QTY AS PER ORDER) ZINTRA BAFFLE



(3 PER BAFFLE) CUP HOOK



(1 PER BAFFLE) PVC EXTRUSION

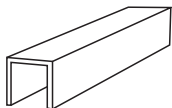

INSTALLATION INSTRUCTIONS

STEP 1

STARTING FROM ONE END PUSH THE PVC CHANNEL ONTO THE TOP EDGE OF THE BAFFLE.

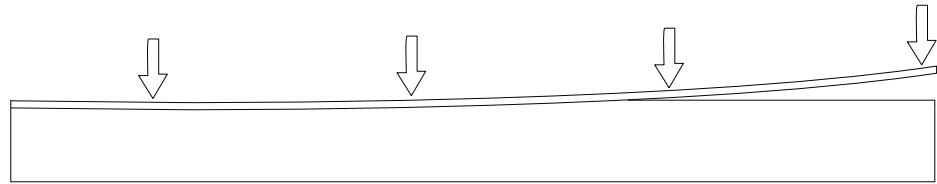

STEP 2

MARK HANGER LOCATION ON CHANNEL CORRESPONDING TO AVAILABLE HANGING LOCATIONS IN CEILING.

NOTE: CABLES MUST HANG PLUMB.

PREDRILL AND SCREW CUP HOOKS INTO CHANNEL AT THESE LOCATIONS

Recommended
Spacing

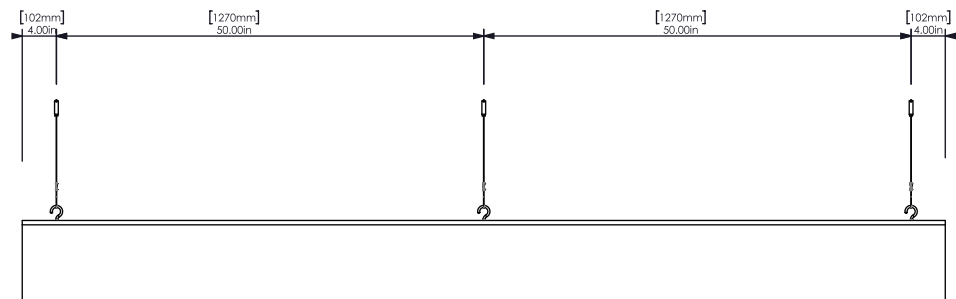

STEP 3

AFTER IDENTIFYING EACH CORRESPONDING POINT ON THE CEILING SUBSTRATE TO THE POINTS MARKED IN STEP 2, DRILL AND ATTACH 1/4"-20 DOUBLE SIDED HANGER BOLT TO SUBSTRATE (SUPPLIED FOR WOOD ANCHORING ONLY). FOR ALL OTHER SUBSTRATES, STUDS/ANCHORS MUST BE SOURCED BY THE INSTALLER.

REFER TO WORKSHOP DRAWING FOR CORRECT BAFFLE SPACING.

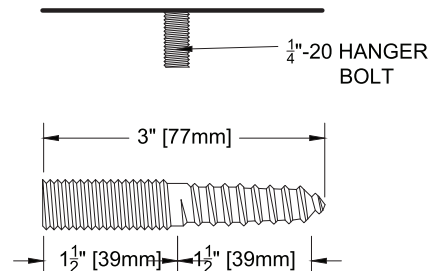

ZINTRA

INDIVIDUAL CUP HOOK BAFFLE INSTALLATION INSTRUCTIONS

STEP 3

A. IDENTIFY THE THREADED END OF THE BARREL AND THE SWAGE END OF THE WIRE.

B. INSERT THE PLAIN END OF THE SUPPLIED WIRE THROUGH THE LARGE THREADED END OF THE BARREL UNTIL THE SWAGE END IS SEATED IN THE BARREL.

C. ATTACH THE THREADED END OF THE BARREL TO 1 / 4"-20 HANGER BOLT.

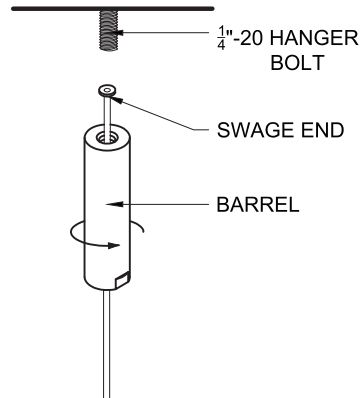

STEP 4

A. INSERT THE PLAIN END OF THE SUPPLIED WIRE THROUGH ONE SIDE OF THE ADJUSTABLE FASTENER

B. REINSERT THE PLAIN END OF THE WIRE INTO THE REMAINING SIDE OF THE ADJUSTABLE FASTENER AND ADJUST TO MAKE A LOOP

C. HANG THE BAFFLES BY THE CUP HOOKS THROUGH THE LOOPS CREATED

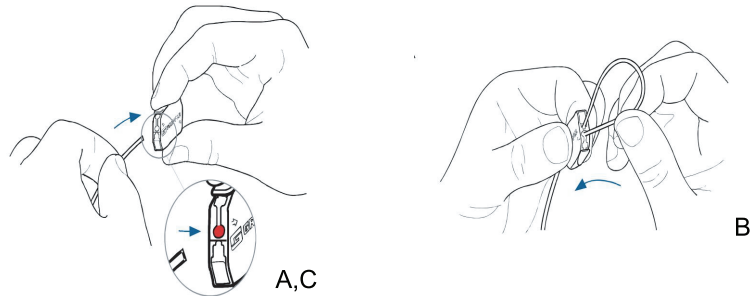

STEP 5

ONCE THE BAFFLE IS PROPERLY SUSPENDED AND LEVEL IS CHECKED USING A SPIRIT LEVEL, ENSURE THE CABLE TENSION IS ALL EQUAL AND NO BOWING IS OCCURRING

TRIM THE EXCESS WIRE WITH WIRE CUTTERS

NOTE: WIRE IS INDEFINITELY ADJUST-ABLE BY DEPRESSING TAB ON APPROPRIATE SIDE

