

# Handbremsventil

## Hand Brake Valve

961 723



Technische Daten / Technical Data:	
Betriebsdruck Operating pressure	max. 10 bar
Zulässiges Medium Permissible medium	Luft / air
Therm. Anwendungsbereich Operating temperature range	-40°C bis/to +80°C

Erläuterung / Explan: R = Raststellung / Locked Position

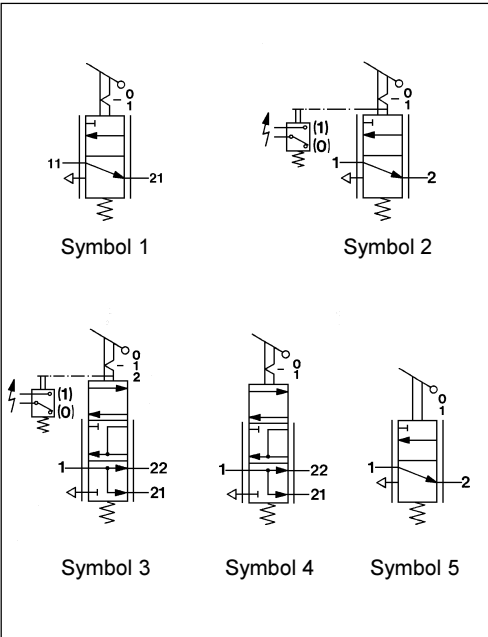

### Einbaumaße / Installation:

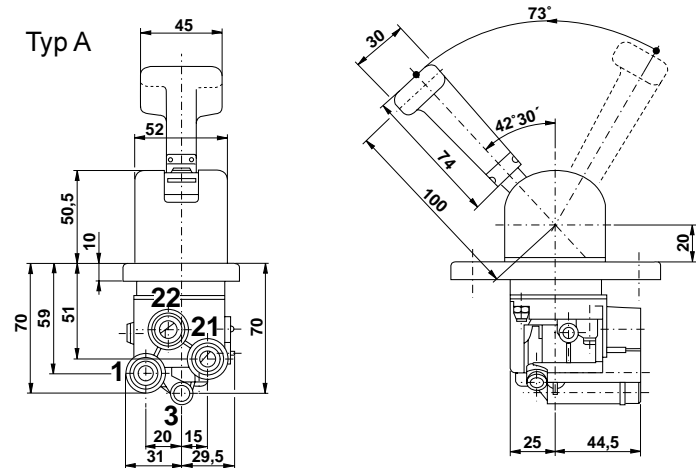

### Anschlüsse / Ports:

- (1) 1 = Energiezufuß  
Energy supply
- (2) 2 = Federspeicherzylinder  
Spring brake actuator
- 22 = Anhänger-Steuerventil  
Trailer control valve
- 3 = Entlüftung / Exhaust

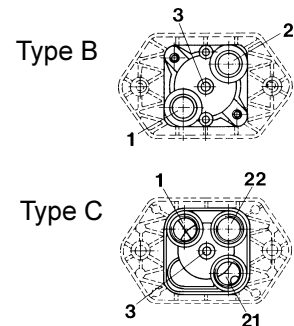

### Entlüftungsstutzen / Venting nipple :

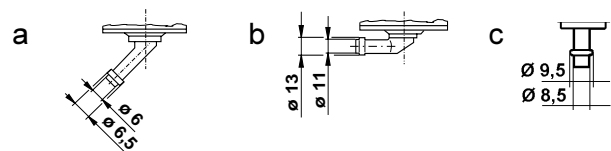

### Zweck:

Feinfühlig abstufbare Betätigung der Hilfsbremsanlage sowie der Feststellbremsanlage in Verbindung mit Federspeicherzylinder.

### Einbauempfehlung:

Das Handbremsventil ist mit 2 Schrauben M6 bzw M8 im Armaturen Brett zu befestigen.

### Purpose:

Sensitive graduated operation of the auxiliary brake and operation of the parking brake in conjunction with spring brake actuator.

### Installation Requirement:

The hand brake valve should be mounted on a panel with two M6 or M8 screws.

### Trägerplatten / Carrier plates:

Typ der Trägerplatten Type of Carrier plate	Maß B	Maß A
I	M 6	80
II	M 8	90
III	Ø 6	80
IV	M8	80

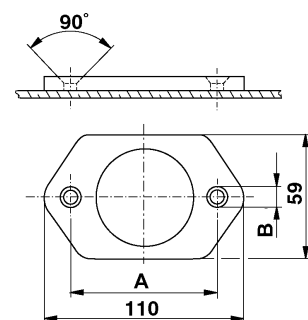

# Handbremsventil

## Hand Brake Valve

961 723

Bestellnummer Part Number	Charakteristik Characteristic	Type	Symbol	Entlüftungs- stutzen Venting nipple	Trägerplatte Carrier plate	Griffform Handle	Bemerkungen Comments
961 723 001 0		B	1	a	I		
		2x M16x1,5 Parker 					
961 723 002 0		B	2	a	I		mit Elektroschalter with electrical switch
		2x M16x1,5 Parker 					
961 723 003 0		B	1	c	I		
		2x M16x1,5 Parker 					
961 723 004 0		B	1	c	I		
		2x M16x1,5 Parker 					
961 723 005 0		A	1	b	II		
		2x M16x1,5 Voss 					
961 723 007 0		A	2	b	I		mit Elektroschalter with electrical switch
		2x M16x1,5 Parker 					
961 723 009 0		A	2	b	II		mit Elektroschalter with electrical switch
		2x M16x1 5 Voss 					

# Handbremsventil

## Hand Brake Valve

# 961 723

Bestellnummer Part Number	Charakteristik Characteristic	Type	Symbol	Entlüftungs- stutzen Venting nipple	Trägerplatte Carrier plate	Griffform Handle	Bemerkungen Comments
961 723 010 0		B	1	a	I		
				2x M16x1,5 Parker			
961 723 012 0		B	2	a	I		
				2x M16x1,5 Parker			
961 723 016 0		B	1	c	I		
				2x M16x1,5 Parker			
961 723 017 0		A	1	a	I		
				2x M16x1,5 Voss			
961 723 022 0		B	1	a	I		
				2x M16x1,5 Parker			
961 723 028 0		A	1	d	IV		Anschluß 3 / Port 3 = M16x1,5 Voss
				2x M16x1,5 Voss			
961 723 030 0		A	1	a	I		
				2x M16x1,5 Voss			

# Handbremsventil

## Hand Brake Valve







# 961 723

Bestellnummer Part Number	Charakteristik Characteristic	Type	Symbol	Entlüftungs- stutzen Venting nipple	Trägerplatte Carrier plate	Griffform Handle	Bemerkungen Comments
961 723 100 0		C	4	c	III		
		3x M16x1,5 Parker					
961 723 102 0		C	4	a	I		
		3x M16x1,5 Parker					
961 723 104 0		A	4	b	II		
		3x M16x1,5 Voss					
961 723 106 0		A	3	b	I		mit Elektroschalter with electrical switch
		3x M16x1,5 Parker					
961 723 107 0		A	3	b	II		mit Elektroschalter with electrical switch
		3x M16x1,5 Voss					
961 723 108 0		C	4	a	I		
		3x M16x1,5 Parker					
961 723 109 0		C	4	a	I		
		3x M16x1,5 Parker					

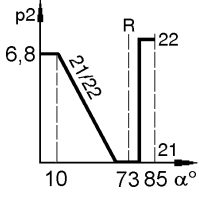
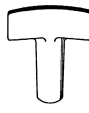
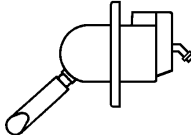
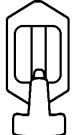
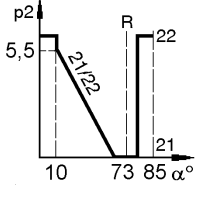
# Handbremsventil

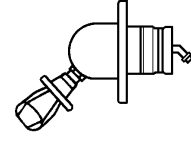
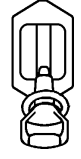
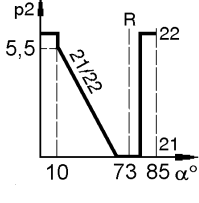
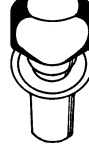
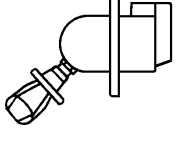
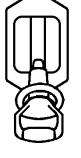
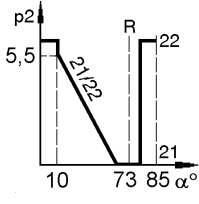
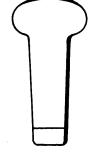
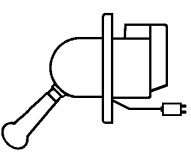
## Hand Brake Valve

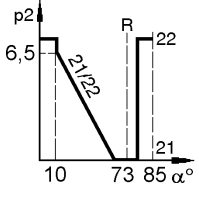
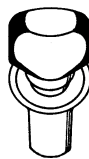
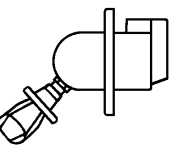
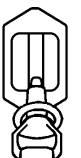
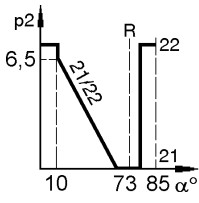
961 723

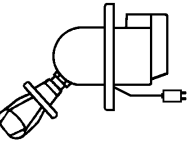
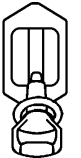
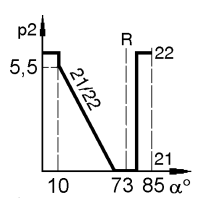
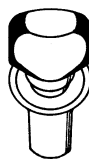
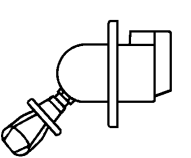
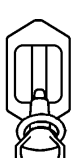
Bestellnummer Part Number	Charakteristik Characteristic	Type	Symbol	Entlüftungs- stutzen Venting nipple	Trägerplatte Carrier plate	Griffform Handle	Bemerkungen Comments
961 723 110 0		A	4	a	I		
		3x M16x1,5 Voss					
961 723 111 0		C	4	a	I		
		3x M16x1,5 Parker					
961 723 112 0		A	4	b	II		
		3x M16x1,5 Voss					
961 723 117 0		A	3	b	I		mit Elektroschalter with electrical switch
		3x M16x1,5 Parker					
961 723 118 0		A	4	b	II		
		3x M16x1,5 Voss					
961 723 120 0		A	3	b	II		mit Elektroschalter with electrical switch
		3x M16x1,5 Voss					
961 723 124 0		A	4	b	IV		
		3x M16x1,5 Parker					

# Handbremsventil

## Hand Brake Valve







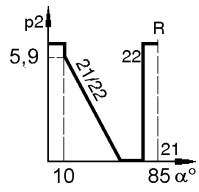
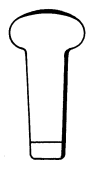
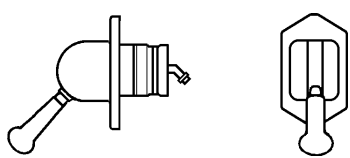
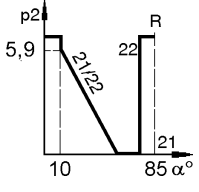
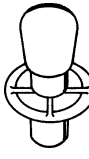
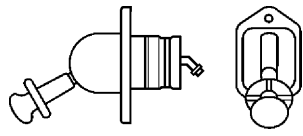
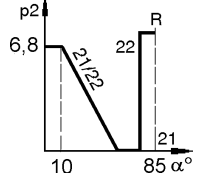

# 961 723

Bestellnummer Part Number	Charakteristik Characteristic	Type	Symbol	Entlüftungs- stutzen Venting nipple	Trägerplatte Carrier plate	Griffform Handle	Bemerkungen Comments
961 723 125 0		A	4	d	IV		Anschluß 3 / Port 3 = M16x1,5 Voss
		3x M16x1,5 Voss					
961 723 126 0		A	4	a	I		
		3x M16x1,5 Voss					
961 723 127 0		A	4	a	I		
		3x M16x1,5 Voss					
961 723 130 0		A	4	a	I		
		3x M16x1,5 Voss					
961 723 200 0		C	4	a	I		
		3x M16x1,5 Parker					
961 723 201 0		A	4	b	II		
		3x M16x1,5 Voss					
961 723 203 0		C	4	a	I		
		3x M16x1,5 Parker					

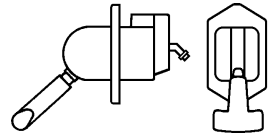
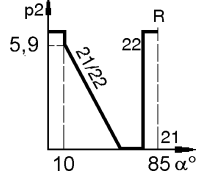
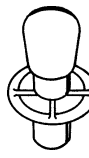
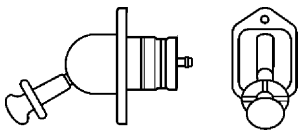
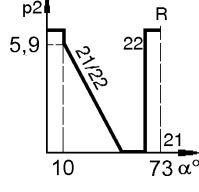
# Handbremsventil

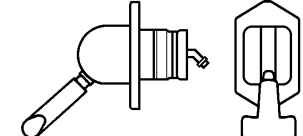
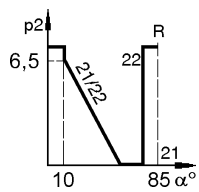
## Hand Brake Valve

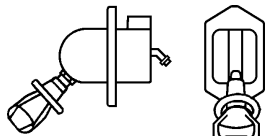
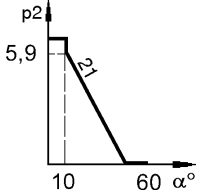
961 723

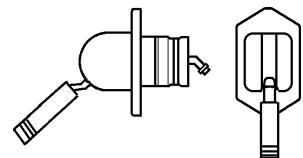
Bestellnummer Part Number	Charakteristik Characteristic	Type	Symbol	Entlüftungs- stutzen Venting nipple	Trägerplatte Carrier plate	Griffform Handle	Bemerkungen Comments	
961 723 204 0		C	4	a	l			
		3x M16x1,5 Parker						
961 723 208 0		C	4	a	l			
		3x M16x1,5 Parker						
961 723 209 0		A	4	a	l			
		3x M16x1,5 Voss						
961 723 212 0		C	4	a	l			
		3x M16x1,5 Parker						
961 723 215 0		C	4	a	l			
		3x M16x1,5 Parker						
961 723 216 0		A	4	a	l			
		3x M16x1,5 Voss						
961 723 402 0		B	5	a	l			
		3x M16x1,5 Parker						

# Handbremsventil

## Hand Brake Valve

961 723

Bestellnummer Part Number	Charakteristik Characteristic	Type	Symbol	Entlüftungs- stutzen Venting nipple	Trägerplatte Carrier plate	Griffform Handle	Bemerkungen Comments
961 723 405 0		B	5	a	I		
		2x M16x1,5 Parker					
961 723 410 0		B	5	a	I		
		2x M16x1,5 Parker					
961 723 414 0		B	5	a	I		
		2x M16x1,5 Parker					
961 723 421 0		A	1	b	IV		
		2x M16x1,5 Voss					
961 723 423 0		A	1	b	II		
		2x M16x1,5 Voss					