



rolly toys Kundendienst Deutschland:

Tel: +49 (0) 95 68 / 856-142

Fax: +49 (0) 95 68 / 856-183

e-mail: service@rollytoys.de



2021/04

700.000.803.00

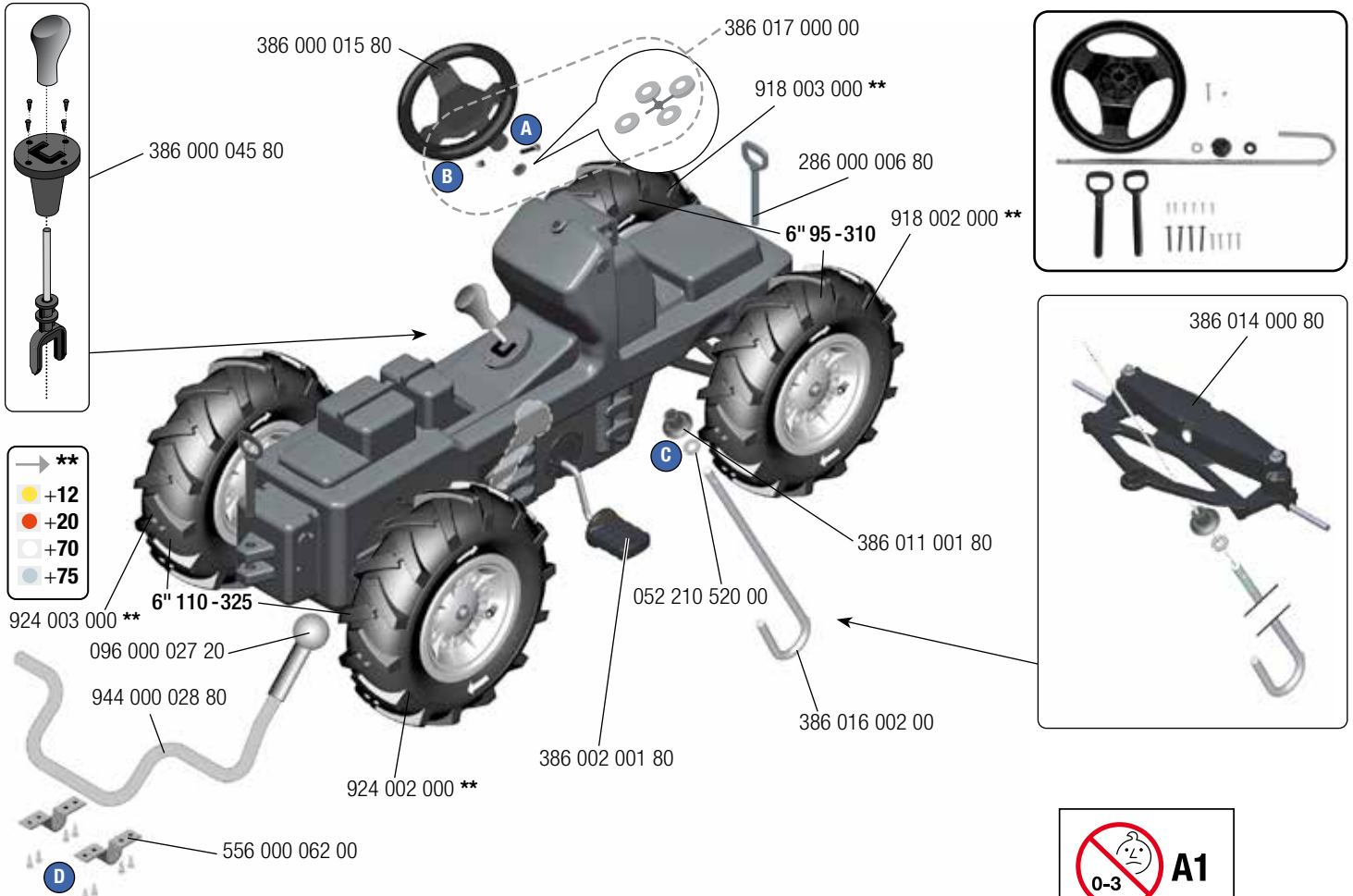

- **
- +12
- +20
- +70
- +75

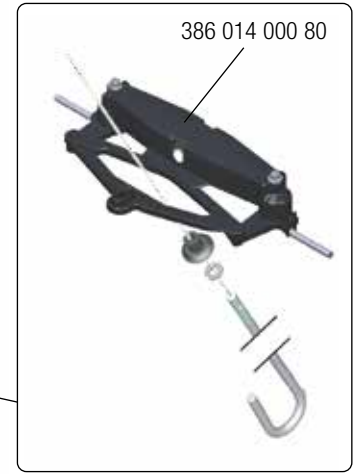

A M5 x 30
1x

B M5
1x

C Ø20 x Ø10,5 x 1
1x

D Ø5 x 20
8x

0 10 20 30 40 50 mm
(metrisch • metric)

BG Предупреждение!	LT Įspėjimas!
CZ Varování!	LV Uzmanību!
D Achtung!	M Avvis!
DK Advarsel!	MK Внимание!
E Aviso!	N OBS!
EST Hoiatus!	NL Waarschuwing!
F Attention!	P Aviso!
FIN Varoitus!	PL Ostrożnie!
GB Warning!	RO Avertisment!
GR Προσοχή!	RUS Внимание!
H Figyelmeztetés!	S Varning!
HR Pažnja!	SK Varovanie!
I Avviso!	SLO Opozorilo!
IRL Rabhán!	TR Dikkat!

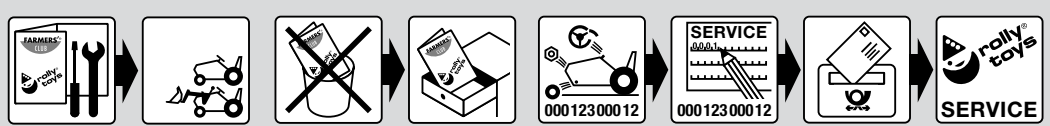

WARNING:
CHOKING HAZARD – Small parts.
Not for children under 3 years.



Franz Schneider GmbH & Co KG
P.O.Box 1460
D-96459 · Neustadt bei Coburg · Germany
Tel.: +49 (0) 95 68 / 856-0
Fax.: +49 (0) 95 68 / 856-180
www.rollytoys.com

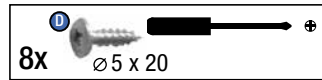
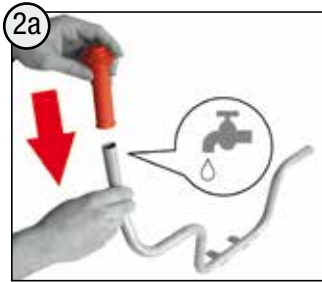
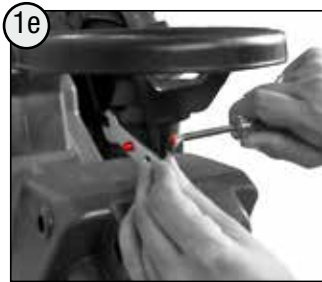
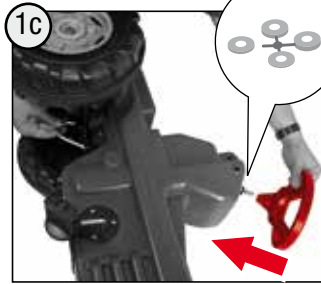
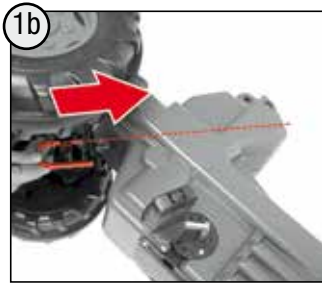
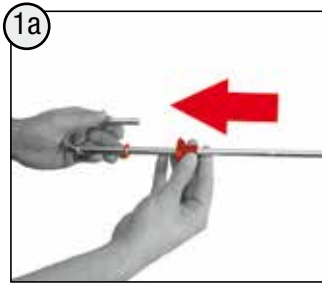

---NORTH & SOUTH AMERICA only---

180 days warranty

From the date of purchase + guaranteed spare part service

The warranty does not cover damages caused by improper use or neglect

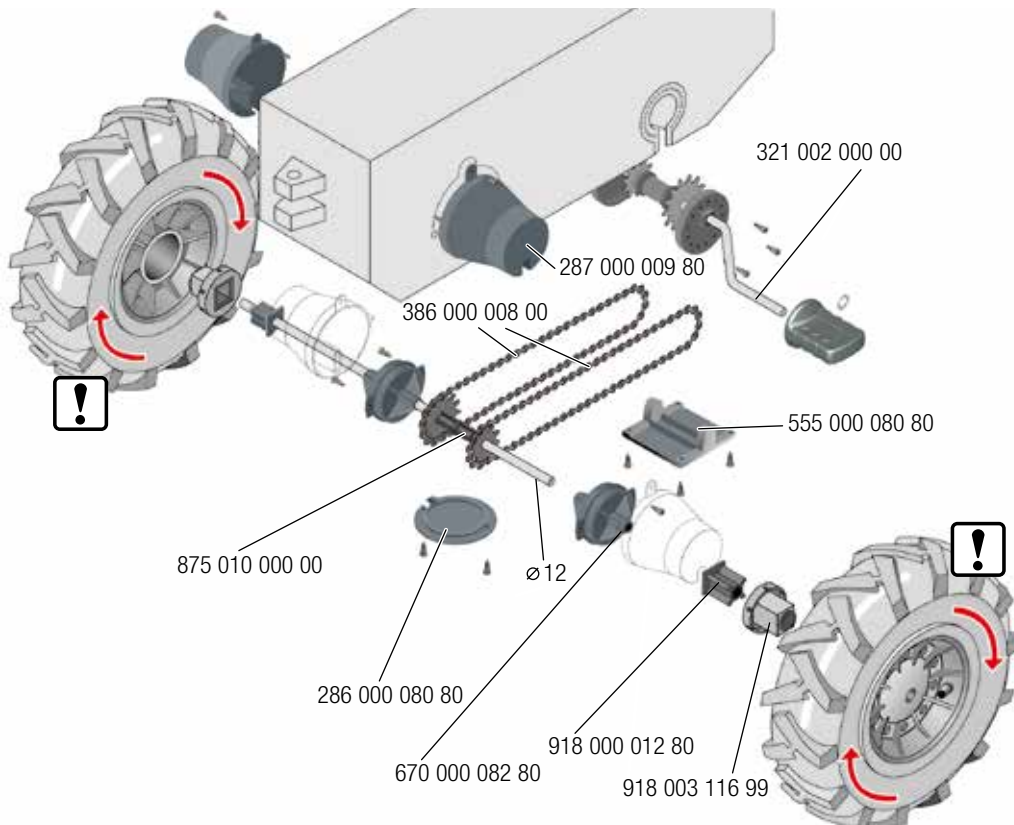

WARNING

- **CHOKING HAZARD:** Small parts. Danger of being swallowed. Contains small parts in non assembled state. Must be assembled by adults.
- Adult supervision required.
- Never use near steps, slopes, driveways, hills, roadways, alleys or swimming pool areas.
- Always wear shoes.
- Never allow more than one rider.
- The use of protective gear and a safety helmet is highly recommended.
- Conforms to the requirements of ASTM Standard Consumer Safety Specification on Toy Safety, F 963
- Not suitable for children under 3 years.