



# Montageanleitung Kabeldurchführung

- D** Kabeldurchführung für Akku-Lagerschrank FMplus – Montageanleitung Original – **Best.-Nr. 11660**
- GB** Cable transit device for battery storage cabinet FMplus **Order No. 11660**
- F** Presse-étoupe pour armoire anti-feu FMplus **réf. 11660**



①

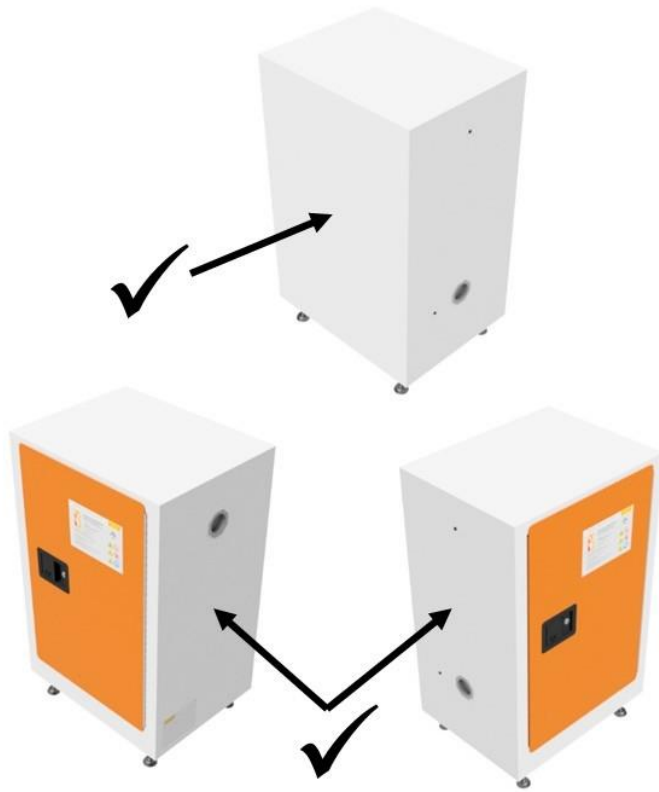

②

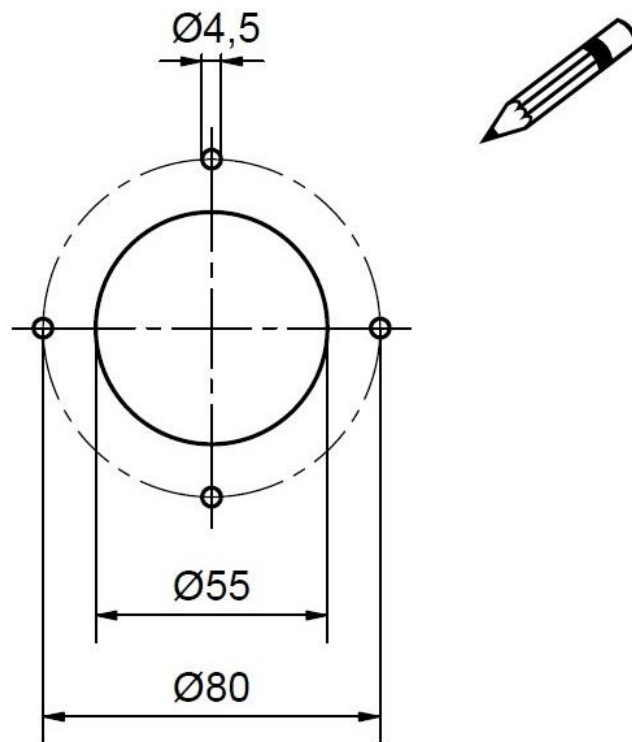

③

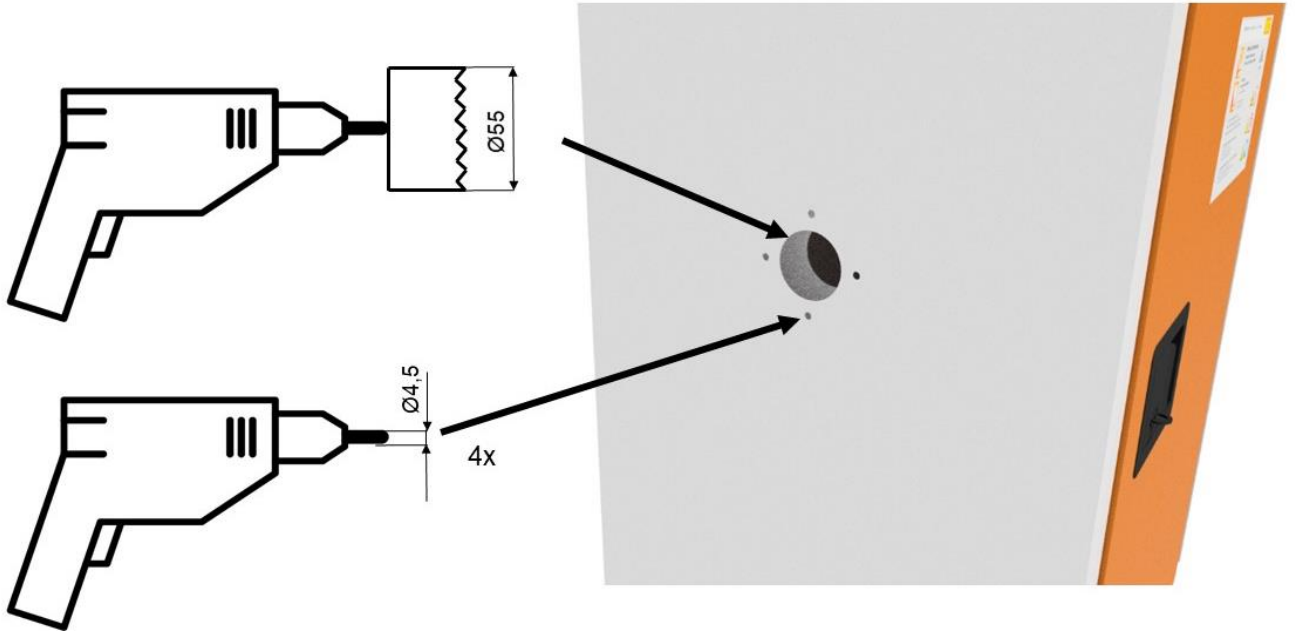

④



⑤

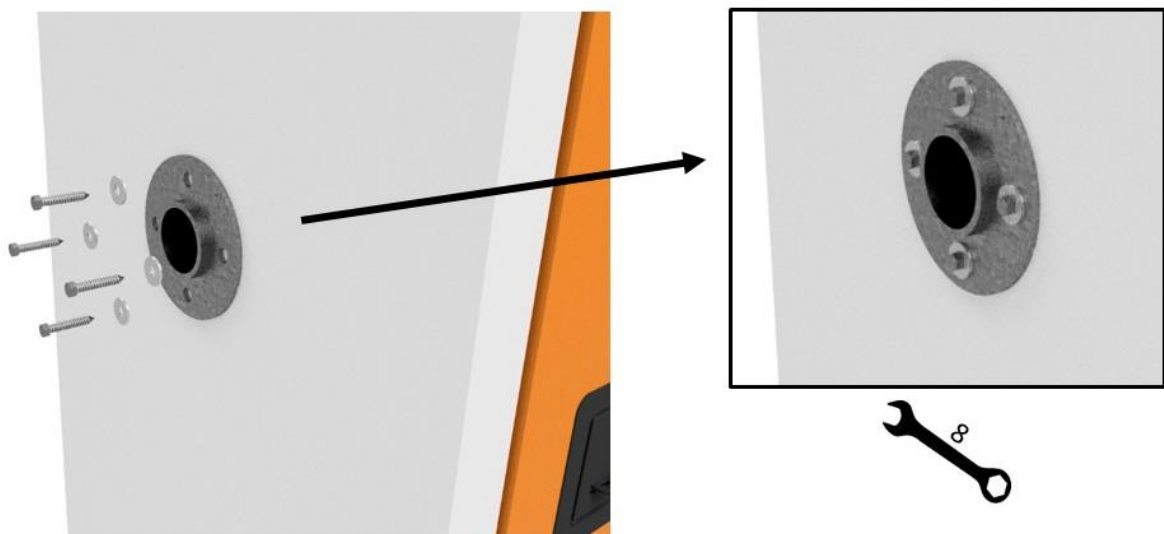

⑥

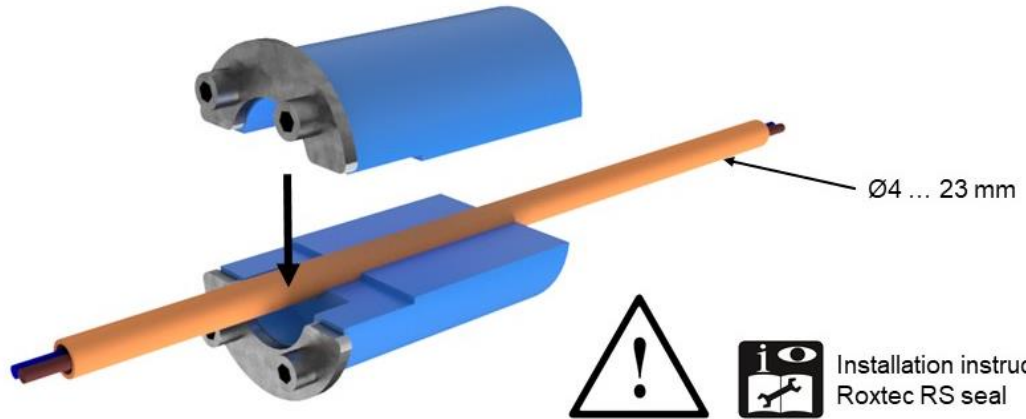

⑦



⑧

