

ELPARTS

**Blitz-Kennleuchte
Bedienhinweis**

**Flashing beacon
Operating Instruction**

**Feu à éclats
Notice d'emploi**

DE

EN

FR

DE

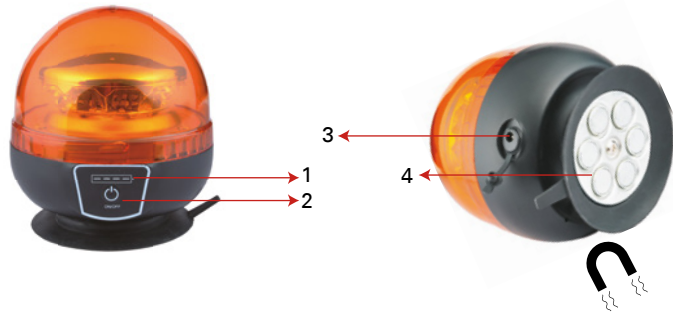

1. Akku-Statusanzeige
2. EIN/AUS-Schalter/Funktionsschalter
3. Ladeanschluss
4. Magnetfuß

WICHTIG

- vor Gebrauch sorgfältig lesen
- Aufbewahren für späteres Nachschlagen
- eine aktuelle Version des Bedien-/Einbauhinweises steht Ihnen auch in unserem Online-Katalog zur Verfügung: herthundbuss.com/Online-Katalog



Technische Daten:

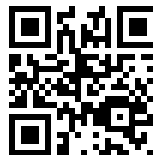

DE

Spannung	12-24 V DC oder 220 V AC	Kabellänge	4000mm
Watt	8,4/36/40	Höhe	140mm
Muster	3 (einfach, doppelt, Rundumleuchte)	Durchmesser	128mm
IP-Schutzklasse	IP65	E-Zulassung	ECE R65
Farbe Lichtscheibe	gelb	EMV-Zertifikat	ECE R10
Farbe LED	gelb		

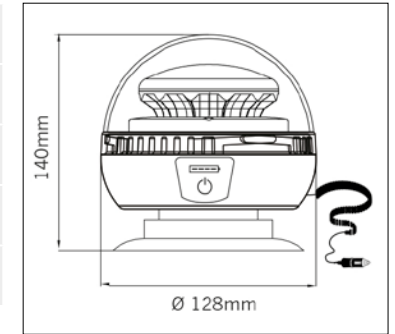

Leuchte einschalten

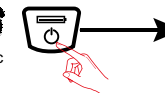

Battery 100% 25%
Akkustatusprüfung



Leuchte ausschalten

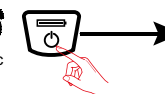

Funktion ändern

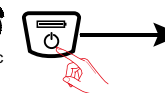

DE

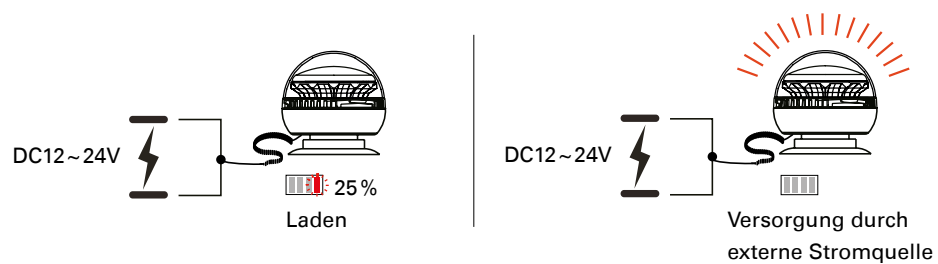
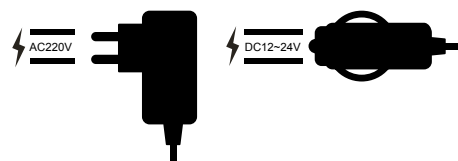

1. Vor dem Gebrauch Akku vollständig laden
2. Akkulaufzeit vor Gebrauch prüfen
3. Leuchte vor Gebrauch auf ordnungsgemäße Funktion prüfen
4. Akku alle 6 Monate laden, wenn nicht in Gebrauch
5. Leuchte regelmäßig überprüfen, wenn sie für längere Zeit nicht in Gebrauch ist

- Ladezeit: 6-8 Stunden
- Entladezeit: einfach blinkend - 4 Stunden
doppelt blinkend - 4 Stunden
Rundumleuchte - 6 Stunden

DE

EN

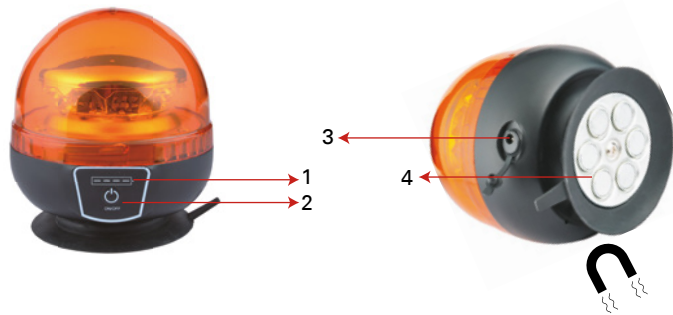

- 1. Battery Status Display
- 2. ON/OFF Switch /Function Switch
- 3. Charging Port
- 4. Magnetic Base

IMPORTANT

- Read carefully before use
- Keep for later reference
- The latest version of the Operating/ Fitting instructions is also available in our online catalogue: herthundbuss.com/online catalogue



EN

Voltage	12-24V DC or 220V AC	Cable length	4000mm
Watt	8,4/36/40	Height	140mm
Patterns	3 (Single, dual, rotating)	Diameter	128mm
IP-class	IP65	E-approved	ECE R65
Color lens	Amber	EMC-certificate	ECE R10
Color LED	Amber		

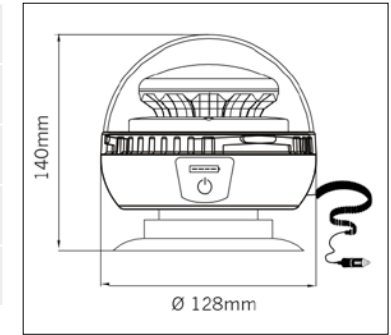

Turn ON Light

1Sec

Battery Status Checking

100% 25%

Turn OFF Light

1Sec

Change Function

5Sec

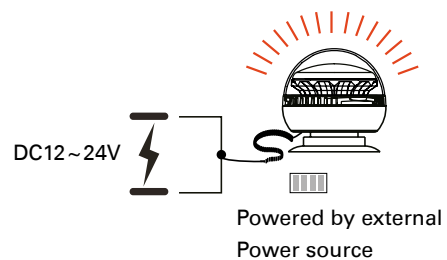
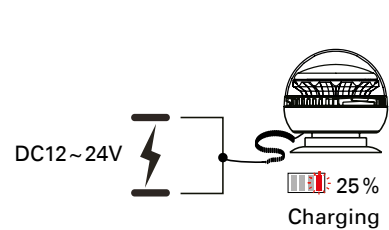
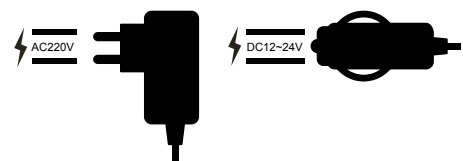

1. Fully charge battery before use
2. Check the battery life before use
3. Check light if working correctly before use
4. Charge the battery every 6 months if not in use
5. Check light regularly when use for long hours

- Charging time: 6-8 hours
- Discharging time: Single Flashing –4 hours
Dual Flashing –4 hours
Rotating –6 hours

FR

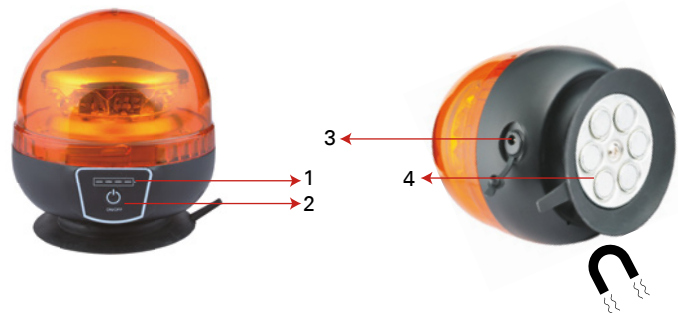

1. Affichage de l'état de la batterie
2. Bouton ON/OFF / Bouton de fonction
3. Port de recharge
4. Embase magnétique

IMPORTANT

- Lire attentivement avant utilisation
- Conserver pour consultation ultérieure
- Vous trouverez également une version actuelle des consignes d'utilisation / d'installation dans notre catalogue en ligne : herthundbuss.com/catalogue en ligne



Caractéristiques techniques :



FR

Tension	12-24V DC or 220V AC	Longueur du câble	4000mm
Puissance	8,4/36/40	Hauteur	140mm
Motifs	3 (Single, dual, rotating)	Diamètre	128mm
Classe IP	IP65	Marquage E selon	ECE R65
Couleur du disperseur	ambre	Certificat CEM selon	ECE R10
Couleur des LED	ambre		

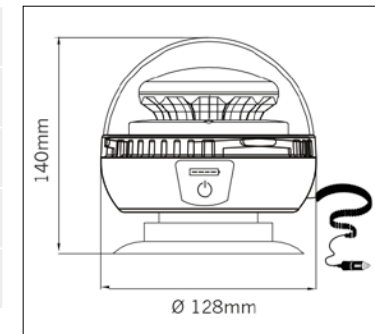

Allumage avertisseur

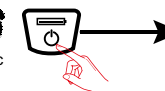

Battery 100% 25%
Vérification de l'état de la batterie



Extinction avertisseur

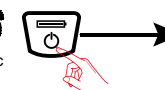

Commutation

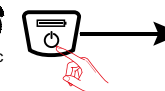

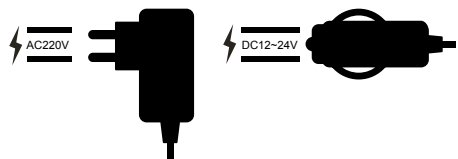

FR



FR

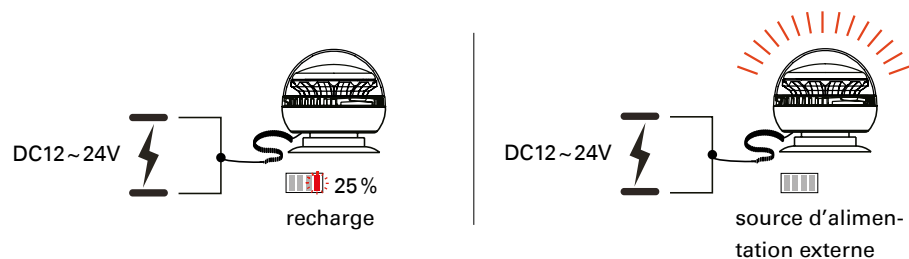

1. Recharger la batterie entièrement avant utilisation
2. Vérifier l'autonomie de la batterie avant utilisation
3. Vérifier que le témoin fonctionne correctement avant utilisation
4. Recharger la batterie tous les 6 mois en l'absence d'utilisation
5. Vérifier le témoin régulièrement pendant les longues périodes de fonctionnement

Recharge : 6-8 heures
 Décharge : clignotement simple 4 heures
 clignotement double 4 heures
 giratoire 6 heures

Herth+Buss Fahrzeugteile GmbH & Co. KG
Dieselstraße 2-4 | DE-63150 Heusenstamm

Herth+Buss France SAS
ZA Portes du Vercors, 270 Rue Col de La Chau
FR-26300 Châteauneuf-sur-Isère

Herth+Buss Belgium Sprl
Rue de Fisine 9 | BE-5590 Achêne

Herth+Buss UK Ltd.
Unit 1 Andyfreight Business Pk
Folkes Road, Lye | GB-DY9 8RB Stourbridge

Herth+Buss Iberica
C/A 44 Polígono de Areta
31620 Huarte Navarra | España