

# Schnellöseventil

## Quick Release Valve

973 500



Type 1

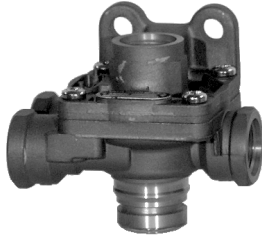

Type 2



Type 3

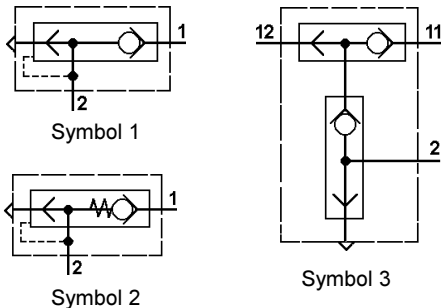

### Zweck:

Schnelle Entlüftung von längeren Steuerleitungen oder Bremsleitungen und Bremszylindern.

### Einbauempfehlung:

Das Ventil wird mit zwei Schrauben M8 so nah wie möglich an die Bremszylinder montiert. Die Entlüftung zeigt nach dem Einbau nach unten.

### Purpose:

Rapid exhausting of long control and brake lines and cylinder.

### Installation Requirement:

The valve should be mounted with two M8 screws, preferably as close to the brake chambers as possible. The exhaust must point downwards when installed.

### Technische Daten / Technical Data:

Betriebsdruck Operating Pressure	siehe Tabelle see table
Zulässiges Medium Permissible Medium	Luft / air
Thermischer Anwendungsbereich Operating temperature range	-40°C bis/to +80°C
Nennweite Nominal diameter	Ø 14 mm

### Einbaumaße / Installation:

Type 1

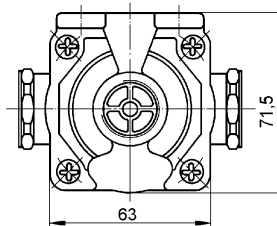
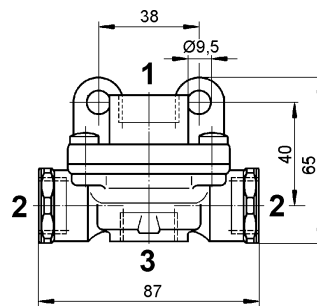

Type 2

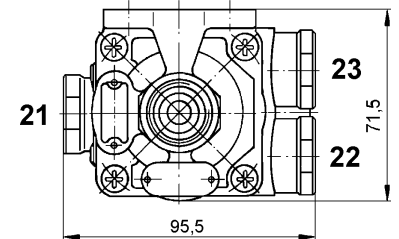
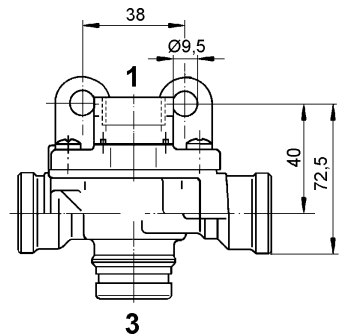

Type 3

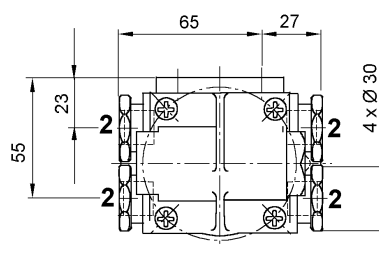
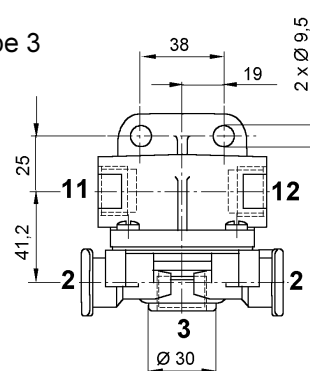

# Schnellöseventil

# 973 500

## Quick Release Valve

Bestellnummer Part Number	Type	Symbol	Betr. Druck Oper. Pressure	Anschlüsse / Ports				Bemerkungen Comments
				1	Ausgesteuert Delivery	2	3	
973 500 000 0	1	1	12	M 22x1,5	M 22x1,5	2x	M 22x1,5	
973 500 003 0	1	1	10	G 3/8"	G 3/8"	2x	G 3/8"	3 = Mit Entlüftungsventil 3 = with venting valve
973 500 005 0	1	1	10	M 22x1,5	M 22x1,5	2x	M 22x1,5	
973 500 006 0	1	1	10	M 16x1,5 Parker	M 16x1,5 Parker	2x	M 16x1,5 Parker	
973 500 028 0	2	1	12	M 22x1,5 Voss	21/22= M 22x1,5 Voss 23= M16x1,5 Voss	3x	Schnapp	
973 500 031 0	2	1	12	M 22x1,5 Voss	21/23= M 22x1,5 Voss 22= M16x1,5 Voss	3x	Schnapp	Unterteil um 90° gedreht Lower part turned by 180°
973 500 034 0	2	1	12,5	M 22x1,5 Voss	M 22x1,5 Voss	2x	Schnapp	23 = nicht gebohrt 23 = not bored
973 500 042 0	2	2	12,5	M 22x1,5 Voss	M 22x1,5 Voss	2x	M 22x1,5	23 = nicht gebohrt 23 = not bored
973 500 051 0	3	3	12	11/12 = M 22x1,5	M 22x1,5	4x	M 22x1,5	