

Dreiwegeventil

3-Way Valve

463 013



Technische Daten / Technical Data:	
Betriebsdruck Operating Pressure	max. 10 bar
Zulässiges Medium Permissible Medium	Luft / air
Therm. Anwendungsbereich Operating temperature range	-40°C bis/to +80°C
Nennweite Nominal diameter	Ø 4 mm

Einbaumaße / Installation:

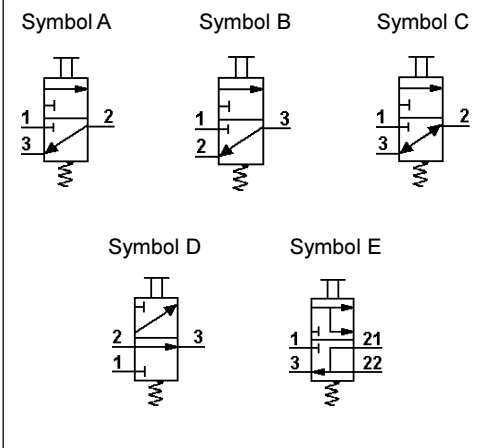

Type 1

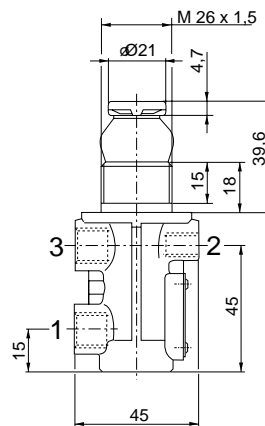

Type 2

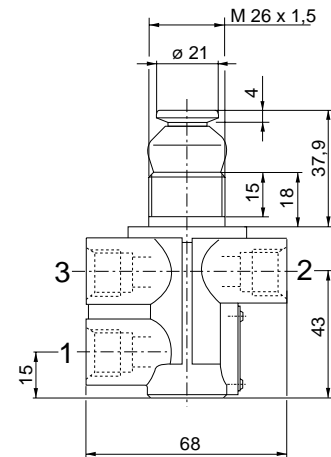

Zweck:

Be- und Entlüften von Arbeitszylindern, z.B. der Motorstaudruckbremsanlage.

Einbauempfehlung:

Das Ventil wird mit der Befestigungsmutter M 26x1,5 im Fahrerhaus installiert.

Purpose:

To pressurize and exhaust operating cylinders e. g. exhaust braking system.

Installation Requirement:

The valve should be installed in the cab with threaded nut M 26x1,5.

Type 3

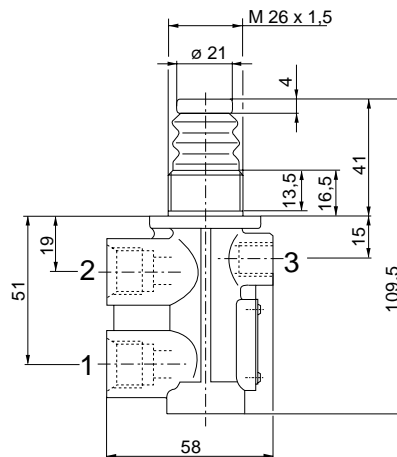

Type 4

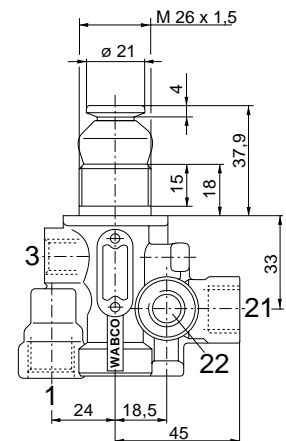

Type a

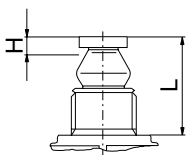

Type b

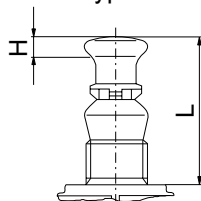

Type c

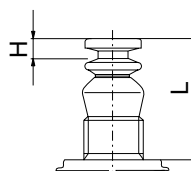

Type d

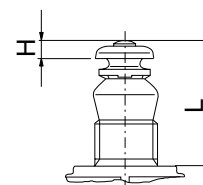

Type e

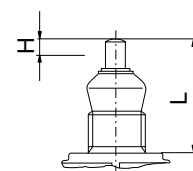

Dreiwegeventil

3-Way Valve

463 013

Bestellnummer Part Number	Type	Maß Dimension "L"	Hub Stroke "H"	Betätigungs-kraft Actuating force		Haltekraft Holding force		Symbol	Anschlüsse / Ports		
				bei Vorratsdruck at supply pressure					1	2	3
				pe 5bar	pe 7bar	pe 5bar	pe 7bar				
463 013 110 0	1/d	46,9	5,7	72 1	90 1	45 1	48 1	A	VorrDt 6 upply M 12x1,5	AEfluß Delivery M 12x1,5	Entlüftung ExhDuMt M 12x1,5
463 013 111 0	1/D	39,6	7,5	80 1	94 1	46 1	50 1	B		Entlüftung ExhDuMt M 12x1,5	AEfluß Delivery M 12x1,5
463 013 112 0	1/D	37,9	5,7	72 1	90 1	45 1	48 1	A		AEfluß Delivery M 12x1,5	Entlüftung ExhDuMt M 12x1,5
463 013 114 0	1/D	95,6	5,7	72 1	90 1	45 1	48 1	A			
463 013 116 0	1/d*	46,9	5,7	72 1	90 1	45 1	48 1	A		Energie DurFhfluß Flow of energy	
463 013 118 0	1/E	130,4	7,5	70 1	80 1	44 1	48 1	D			
463 013 120 0	1/d*	46,9	5,7	72 1	90 1	45 1	48 1	A		AEfluß Delivery M 12x1,5	Entlüftung ExhDuMt M 12x1,5
463 013 121 0	1/D	75,6	5,7	72 1	90 1	45 1	48 1	A			
463 013 124 0	1/D*	37,9	5,7	76 1	90 1	60 1	65 1	C		Energie DurFhfluß Flow of energy	
463 013 126 0	1/E	57	7,5	80 1	94 1	46 1	50 1	D			
463 013 127 0	1/e*	57	8,3	80 1	94 1	46 1	50 1	A	AEfluß Delivery M 12x1,5	Entlüftung ExhDuMt M 12x1,5	
463 013 128 0	1/D*	39,9	7,5	80 1	94 1	46 1	50 1	B	VorrDt 6 upply M16x1,5 VoW	Entlüftung ExhDuMt M 12x1,5	AEfluß Delivery M 12x1,5
463 013 130 0	2/D	37,9	5,7	72 1	90 1	45 1	48 1	A		AEfluß Delivery M16x1,5 VoW	Entlüftung ExhDuMt M16x1,5 VoW
463 013 131 0	2/d	37,9	5,7	72 1	90 1	45 1	48 1	A			
463 013 150 0	1/d	46,9	5,7	60 1	70 1	45 1	50 1	A	VorrDt 6 upply M 12x1,5	AEfluß Delivery M 12x1,5	Entlüftung ExhDuMt M 12x1,5
463 013 200 0	3	41	10	82 1	91 1	74 1	83 1	A	VorrDt 6 upply M16x1,5 VoW	AEfluß Delivery M16x1,5 VoW	Entlüftung ExhDuMt M 12x1,5
463 013 210 0	4	37,9	5,7	72 1	90 1	45 1	48 1	E		AEfluß Delivery 21 M16x1,5 VoW 22 M12x1,5	

*) mit Befestigungsmutter M 26x1,5 (891 500 464 4)

*) with mounting nut M 26x1,5 (891 500 464 4)