

# Automatischer Bremskraftregler

## Load Sensing Valve

475 714



### Technische Daten / Technical Data:

Betriebsdruck Operating Pressure	Bremsteil Braking part	max. 10 bar
	Steuerteil Control part	max. 12 bar
Zulässiges Medium Permissible Medium	Luft / air	
Therm. Anwendungsbereich Operating temperature range	-40°C bis/to +80°C	

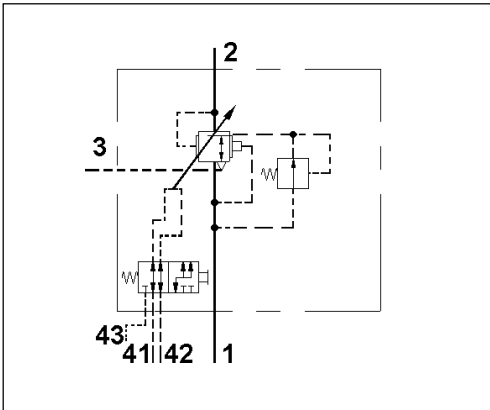

### Einbaumaße / Installation:

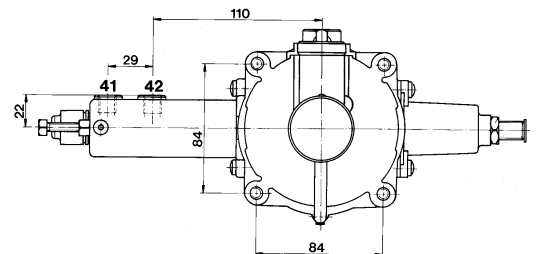
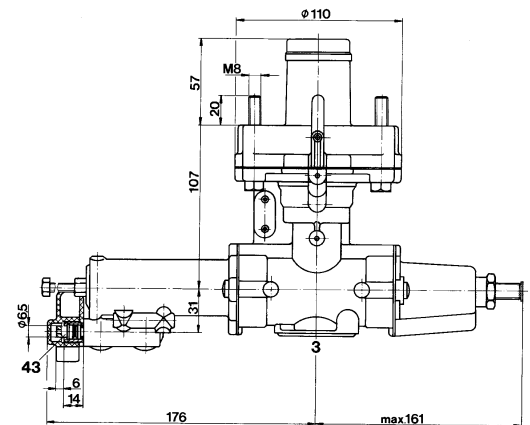
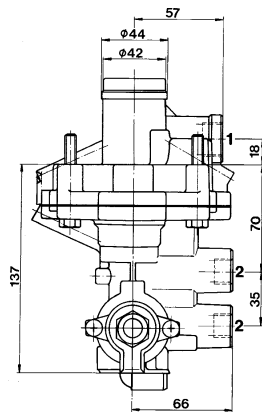

### Zweck:

Automatische Regelung der Bremskraft von Druckluftbremszylindern an luftgefederten Achsen in Abhängigkeit vom Luftfederbalgdruck und damit vom Beladungszustand des Fahrzeuges.

### Einbauempfehlung:

Das Gerät ist senkrecht einzubauen. Zur Befestigung dienen zwei der vier Verbindungsschrauben der Gehäuseteile.

### Purpose:

The automatically control braking force on the air brake chambers of vehicles with air suspended axles. Automatic control is dependent upon the air bag pressure which corresponds to the vehicle load.

### Installation Requirement:

The valve must be installed vertically. Mounting is accomplished using at least two of the four assembling screws provided.

4

# Automatischer Bremskraftregler

## Load Sensing Valve

# 475 714

Bestellnummer Part Number	Charakteristik / Characteristic	Anschlüsse Ports
475 714 500 0		<p>1/4= M 22x1,5                  2 = M 16x1,5                  3 = -                  41 = M 12x1,5                  42 = M 12x1,5                  43 = M 16x1,5</p>
475 714 501 0		<p>1/4= M 22x1,5                  2 = M 16x1,5                  3 = -                  41 = M 12x1,5                  42 = M 12x1,5                  43 = M 16x1,5</p>
475 714 502 0		<p>1/4=M 22x1,5 Parker                  2= M 16x1,5 Parker                  3 = -                  41= M 12x1,5 Parker                  42= M 12x1,5 Parker                  43 = M 16x1,5</p>
475 714 503 0		<p>1/4= M 22x1,5                  2 = M 16x1,5                  3 = Schnapp                  41 = M 12x1,5                  42 = M 12x1,5                  43 = M 16x1,5</p>
475 714 504 0		<p>1/4= M 22x1,5                  2 = M 16x1,5                  3 = Schnapp                  41 = M 12x1,5                  42 = M 12x1,5                  43 = M 16x1,5</p>
475 714 505 0		<p>1/4= M 22x1,5                  2 = M 16x1,5                  3 = -                  41 = M 12x1,5                  42 = M 12x1,5                  43 = M 16x1,5</p>

# Automatischer Bremskraftregler

## Load Sensing Valve

# 475 714

Bestellnummer Part Number	Charakteristik / Characteristic	Anschlüsse Ports
475 714 509 0		<p>1/4= M 22x1,5                  2 = M 16x1,5                  3 = -                  41 = M 12x1,5                  42 = M 12x1,5                  43 = M 16x1,5</p>
475 714 510 0		<p>1/4= M 22x1,5                  2 = M 16x1,5                  3 = -                  41 = M 12x1,5                  42 = M 12x1,5                  43 = M 16x1,5</p>
475 714 511 0		<p>1/4= M 22x1,5                  2 = M 16x1,5                  3 = -                  41 = M 12x1,5                  42 = M 12x1,5                  43 = M 16x1,5</p>
475 714 512 0		<p>1/4= M 22x1,5                  2 = M 16x1,5                  3 = Schnapp                  41 = M 12x1,5                  42 = M 12x1,5                  43 = M 16x1,5</p>

# 4