

# beurer

# IH 61



**EN** Nebuliser  
Instructions for use

**CE** 0483

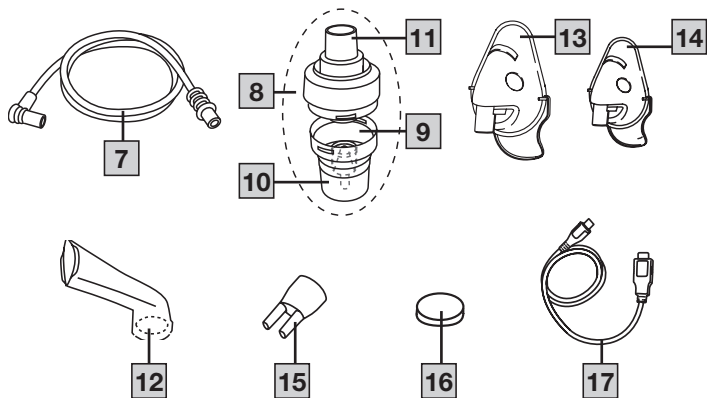
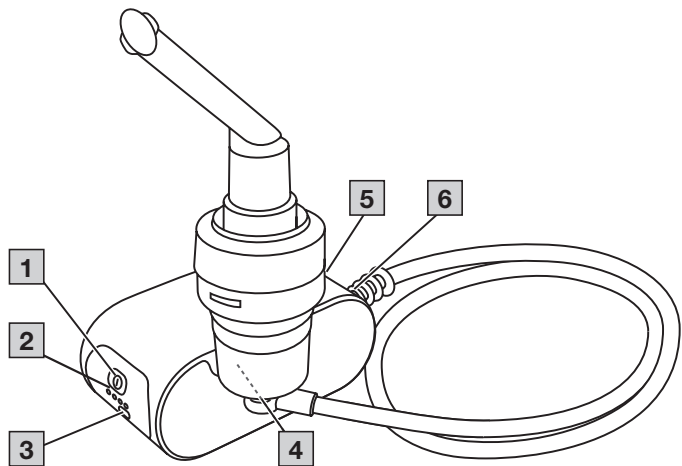

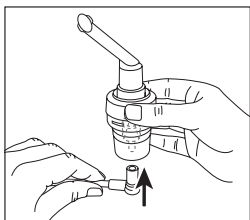
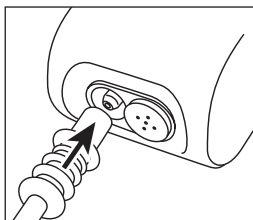
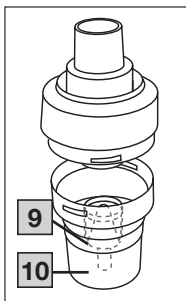
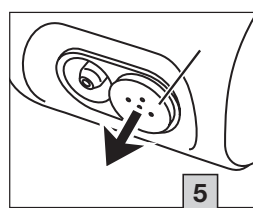
**A****B****C****D****E**



Read these instructions for use carefully and keep them for later use. Make them accessible to other users and note the information they contain.

## Table of contents

1. Included in delivery .....	4
2. Getting to know your device .....	4
3. Signs and symbols .....	4
4. Intended Purpose .....	5
5. Warnings and safety notes .....	6
6. Device and atomiser set description .....	9
7. Initial use .....	10
8. Usage .....	10
9. Changing the filter .....	12
10. Cleaning and maintenance .....	13
11. Accessories and/or replacement parts .....	15
12. What if there are problems? .....	15
13. Disposal .....	16
14. Technical specifications .....	17
15. Guarantee / Service .....	19

## 1. INCLUDED IN DELIVERY

Check that the exterior of the cardboard delivery packaging is intact and make sure that all contents are present. Before use, ensure that there is no visible damage to the device or atomiser set (= year pack) and that all packaging material has been removed. If you have any doubts, do not use the device and contact your retailer or the specified Customer Services address.

- Nebuliser
- Atomiser
- Compressed air hose
- Mouthpiece
- Adult mask
- Children's mask
- Nosepiece
- Replacement filter
- USB-C cable
- Storage bag

- Instructions for use

## 2. GETTING TO KNOW YOUR DEVICE

Please read these instructions for use carefully and keep them for later use, make them accessible to other users, and observe the information they contain.

## 3. SIGNS AND SYMBOLS

The following symbols are used on the packaging and on the type plate for the device and accessories.

### WARNING

Indicates a potentially impending danger. If it is not avoided, there is a risk of death or serious injury.

### CAUTION

Indicates a potentially impending danger. If it is not avoided, slight or minor injuries may result.

### NOTICE

Indicates a potentially harmful situation. If it is not avoided, the system or something in its vicinity may be damaged.





















Applied part, type BF



### Follow the instructions

Read the instructions before starting work and/or operating devices or machines

	Protection class 2 device
	Manufacturer
I	On
O	Off
	Serial number
30 ON/ 30 OFF	30 minutes of operation, then 30 minutes break before operating again.
	Device protected against foreign objects $\geq 12.5$ mm and against water dripping at an angle
	<b>CE labelling</b> This product satisfies the requirements of the applicable European and national directives.
	Marking to identify the packaging material. A = material abbreviation, B = material number: 1-7 = plastics, 20-22 = paper and cardboard
	Separate the product and packaging elements and dispose of them in accordance with local regulations.
	The electronic device must not be disposed of with household waste
	Temperature limit
	Humidity limitation
	Medical device
	Unique device identifier (UDI) Identifier for unique product identification
	Article number

	Reuse on a single patient
	Date of manufacture
	Do not dispose of batteries containing harmful substances with household waste
	Swiss authorised representative
	Battery
	Type number

## 4. INTENDED PURPOSE

### Intended use

Nebulisers (including compressor, ultrasonic and mesh nebulisers) are medical devices for the nebulisation of liquids and liquid medication (aerosols). This device produces aerosols by combining compressed air and liquid medication.

The aerosol treatment is suitable for treating the upper and lower airways.

By nebulising and inhaling the medication prescribed/recommended by your doctor, you can prevent diseases affecting the airways, or in the case that you contract such an illness, you can alleviate symptoms and speed up your recovery.

### Intended users

The nebuliser is intended for use in the home healthcare environment, not in professional healthcare facilities. The nebuliser can be used on anyone over 2 years of age under supervision; it can be used for self-treatment by anyone over 12 years of age. The shape and size of the person's face determines whether or not the device can be used under supervision. As such, it may not be possible to use the device under supervision until a person gets older. When using a mask to inhale, take care to ensure the mask fits well and the eyes are unobstructed.

## Clinical benefits

Inhalation is the most effective way to administer medication for most respiratory system conditions.

The benefits are:

- The medication is carried directly to the target organs
- The local bioavailability of the medication is significantly increased
- Systemic diffusion is reduced substantially
- Only very low doses of the medication are required
- Quick and effective therapeutic effect
- Side effects are significantly reduced compared to systemic administration
- Humidifying the airways
- Loosening and making (bronchial) secretions more liquid
- Releasing bronchospasms (spasmolysis)
- Relieving swollen and inflamed bronchial mucosa
- Coughing up secretions
- Counteracting pathogens of respiratory infections

## Indication

The nebuliser can be used for diseases of the upper and/or lower airways. Examples of upper respiratory system diseases include:

- Nasal mucosal inflammation
- Allergic nasal mucosal inflammation
- Nasal sinus infection
- Pharyngitis
- Laryngitis

Examples of lower respiratory system diseases include:

- Bronchial asthma
- Bronchitis
- COPD (chronic obstructive pulmonary disease)
- Bronchiectasis
- Acute tracheobronchitis
- Cystic fibrosis
- Pneumonia

## Contraindications

- The atomiser is not intended for the treatment of life-threatening conditions.
- This device must not be used by children under the age of 12 and by people with reduced physical, sensory (e.g. reduced sensitivity to pain) or mental skills or a lack of experience or knowledge, unless they are supervised or have been instructed on how to use the device safely, and are fully aware of the consequent risks of use.
- Do not use the device on persons who are ventilated and/or unconscious.
- Check whether there are contraindications for use with the usual systems for aerosol treatment on the medication instruction leaflet.
- If the device does not work properly, or if you feel unwell or experience pain, stop using it immediately.

## 5. WARNINGS AND SAFETY NOTES

### WARNING

- The atomiser has no significant effect on the efficacy and safety of the medication administered and is not intended for the treatment of life-threatening conditions.
- Once it has been properly prepared, the device can be used again. Preparation involves replacing all the components, including the atomiser and air filter, and disinfecting the surface of the device using a standard disinfectant. We recommend replacing the atomiser and other components after one year. For hygiene reasons, it is essential that each user uses their own components.
- You should always follow the instructions of your doctor or pharmacist regarding the type of medication to use, the dosage, and the frequency and duration of inhalation.

- If medication is used/nebulised, the conditions and restrictions applicable to such medication must be adhered to.  
Please note: For treatment, only use parts indicated by your doctor according to the particular diagnosis.
- The device is not a substitute for medical consultation and treatment. Always consult your doctor first in the event of pain or illness.
- If you have health concerns of any kind, consult your GP!
- The particle size distribution curve, MMAD, aerosol delivery and/or aerosol delivery rate may change if a different medication, suspension, emulsion or highly viscous solution is used than the one referenced in the technical specifications for the aerosol values.
- If the liquid you wish to use is not compatible with PP, PC, silicone and PVC, do not use this liquid with our nebuliser. If the information provided with the liquid does not indicate whether the liquid is compatible with these materials, please contact the liquid manufacturer. Sodium fluoride is an example of a compatible substance.
- Please note the general hygiene measures when using the nebuliser.
- Before use, ensure that there is no visible damage to the device or components. If you have any doubts, do not use the device and contact your retailer or the specified Customer Services address.
- Do not use any additional parts that are not recommended by the manufacturer.
- The nebuliser may only be operated with compatible Beurer atomisers and with the appropriate Beurer components. The use of atomisers and components made by other companies may result in less efficient treatment and could damage the device.
- Keep the device away from your eyes when it is in use, as the mist of medication could be harmful.
- Never use the device near flammable gases, oxygen or nitrogen oxide.
- Store the device and components out of the reach of children and pets.
- Keep packaging material away from children (risk of suffocation).
- The device must be switched off and the plug pulled out before every cleaning and/or maintenance procedure.
- Never submerge the device in water and do not use it in the bathroom. Under no circumstances may liquid enter the device.
- If the device is dropped, exposed to high levels of moisture or suffers any other damage, it must no longer be used. If in doubt, contact Customer Services or the retailer.
- Power cuts, sudden interference or other unfavourable conditions could lead to the device becoming inoperable. We therefore recommend that you obtain a replacement device or medication (the latter should be agreed with your doctor).
- To avoid the risk of entanglement and strangulation, store cables and air lines out of the reach of small children.
- The device must only be connected to the mains voltage that is specified on the type plate.
- Never touch the USB-C cable with wet hands, as you could get an electric shock.
- Do not pull the mains adapter out of the socket using the USB-C cable.
- Do not crush or bend the USB-C cable, pull it over sharp-edged objects or leave it dangling down, and protect it from sources of heat.
- If the USB-C cable or the mains adapter is damaged, it must be disposed of. Please contact Customer Services or the retailer.
- If the device is opened, there is a risk of electric shock. Disconnection from the power supply network is only guaranteed if the adapter is unplugged and the

USB-C cable has no other power connection.

## **⚠ CAUTION**

- Never store the device (or the power cable) near to sources of heat.
- If you require a mains adapter, it must comply with the applicable safety requirements (EN 60601-1). The power limit and maximum power specified on the mains adapter must not be exceeded. We recommend using the mains adapter specified in the chapters “Accessories and/or replacement parts” and “Technical data”.
- Do not use the device in a room in which a spray has previously been used. Air the room before carrying out the treatment.
- Never use the device if it is making an abnormal sound.
- Store the device in a location protected from climatic effects. The device must be stored in the environmental conditions specified.
- Do not operate the device near electromagnetic transmitters.
- Protect the device from severe knocks.
- Always disconnect the device from the mains connection after use.
- Should you require an adapter or extension lead, it must meet the applicable safety requirements. The power limit and the maximum output specified on the adapter must not be exceeded.

## **Prior to initial use**

- Remove all packaging material before using the device.
- Protect the device from dust, dirt and humidity and never cover the device while it is in use.
- Do not operate the device in a very dusty area.
- Switch the device off immediately if it is faulty or not working properly.
- The manufacturer is not liable for damage resulting from improper or incorrect use.

## **Repairs**

- Only open the device to replace the battery. Only replace the battery according to the instructions in the chapter “Disposal”, and do not make any further changes. Failure to comply will invalidate the guarantee.
- The device is maintenance-free.
- For repairs, please contact Customer Services or an authorised retailer.

## **Notes on handling batteries**

### **⚠ WARNING**

- **Risk of explosion! Risk of fire!** Failure to comply with the points mentioned can result in personal injury, overheating, leakage, venting, breakage, explosion, or fire.
- Always use the correct or supplied charging cable/charger/mains adapter for charging.
- Avoid continuous charging or overcharging. Unplug the charger when charging is complete.
- Charge the device under supervision, paying attention to any heat generated, deformation, or release of gases. If in doubt, stop charging.
- Dispose of defective batteries/charging cables/chargers immediately and properly (see chapter on disposal).
- Do not use modified or damaged batteries/charging cables/chargers.
- Always select the correct battery type. Contact Customer Services for information on whether a battery replacement part can be replaced.
- Do not throw batteries into a fire.
- Never forcibly discharge, heat, disassemble, open, crush, deform, encapsulate, modify, or knock batteries.
- Never short-circuit batteries or battery compartment contacts.
- Protect the batteries from direct sunlight, rain, heat, and water.

- Exposure of batteries to an environment with extremely high temperatures or an extremely low air pressure may result in explosion or leakage of flammable liquids and gases.
- Always insert the batteries correctly, taking into account the polarity (+ / -).
- If a battery has leaked, put on protective gloves and clean the battery compartment with a dry cloth.
- If fluid from a battery comes into contact with your skin or eyes, wash the affected areas with water and seek medical assistance.
- **Choking hazard!** Keep batteries out of the reach of children. Seek medical attention immediately if swallowed. Swallowing them may cause severe internal burns and death.
- Never allow children to replace batteries without adult supervision.
- The use of an atomiser set other than that specified or provided by the manufacturer of this device can lead to an increase in electromagnetic emissions or a decrease in the device's electromagnetic immunity; this can result in faulty operation.
- Keep portable RF communication devices (including peripheral equipment, such as antenna cables or external antennas) at least 30 cm away from all device parts, including all cables included in delivery.
- Failure to comply with the above could impair the performance of the device.

### **⚠ CAUTION**

- Store battery replacement parts away from metal objects in a well-ventilated, dry, and cool place.
- Keep batteries clean and dry.
- Keep batteries away from water.

### **Notes on electromagnetic compatibility**

- The device is suitable for use in all environments listed in these instructions for use, including domestic environments.
- The device may not be fully usable in the presence of electromagnetic disturbances. This could result in issues such as error messages or the failure of the display/device.
- Avoid using this device directly next to other devices or stacked on top of other devices, as this could lead to faulty operation. If, however, it is necessary to use the device in the manner outlined above, this device as well as the other devices must be monitored to ensure they are working properly.

## **6. DEVICE AND ATOMISER SET DESCRIPTION**

The related illustrations are on page 3.

### **Overview of nebuliser**

- 1 On/Off control
- 2 Battery level display
- 3 USB-C port
- 4 Holder for atomiser
- 5 Filter cap with filter
- 6 Hose connection

### **Overview of atomiser and accessories**

- 7 Compressed air hose
- 8 Atomiser
- 9 Medication container
- 10 Atomiser insert
- 11 Atomiser attachment
- 12 Mouthpiece
- 13 Adult mask

- 14 Children's mask
- 15 Nosepiece
- 16 Replacement filter
- 17 USB-C cable

## 7. INITIAL USE

### Setting up the device

Take the device out of the packaging.  
Place the device on a flat surface.

### Before using the device for the first time

#### NOTICE

- Clean and disinfect the atomiser and atomiser set before using them for the first time. See section "Cleaning and maintenance".
- Connect the compressed air hose **7** to the bottom of the medication container **9**. **A**
- Connect the other end of the compressed air hose **7** to the nebuliser hose connection **6** by turning it slightly. **B**

### Charging the nebuliser battery

To charge the nebuliser battery, proceed as follows:

- Plug the USB-C cable included in delivery into the USB-C port on the nebuliser as shown.
- Plug the other end of the USB C cable into the USB port on the mains adapter (not included in the delivery) and insert the mains adapter into the socket.

#### NOTICE

During the charging procedure, between one (battery almost empty) and four (battery fully charged) LEDs on the battery level indicator **2** flash according to the battery charge lev-

el. As soon as the battery is fully charged, all four LEDs are permanently illuminated. After each use, fully charge the battery of the nebuliser again.

### Switching on the nebuliser

To switch on the nebuliser, proceed as follows:

- Press the ON/OFF button on the nebuliser. The ON/OFF button illuminates blue. The nebuliser is now operational. The battery must be sufficiently charged for the nebuliser to function correctly.

The blue LEDs on the battery level indicator show the current battery level.

1 blue LED flashes	=	Battery is almost flat, nebuliser will soon switch off.
1 blue LED lights up	=	Battery capacity 25%
2 blue LEDs light up	=	Battery capacity 50%
3 blue LEDs light up	=	Battery capacity 75%
4 blue LEDs light up	=	Battery capacity 100%

## 8. USAGE

#### CAUTION

- For hygiene reasons, it is essential to clean the atomiser **8** and the atomiser set after each treatment and to disinfect them after the last treatment of the day.
- The atomiser set parts may only be used by one person; use by several people is not recommended.
- If the therapy involves inhaling several different medications one after the other, please be aware that the atomiser **8** must be rinsed under warm tap water following every usage. See section "Cleaning and maintenance".

- Observe the notes on changing the filter in these instructions for use.
- Check that the hose connectors are firmly attached to the nebuliser **6** and the atomiser **8** before each use of the device.
- Before use, check the device is working correctly by briefly switching on the nebuliser (together with the connected atomiser, but without medication). If air comes out of the atomiser **8**, the device is working.

## 8.1 Inserting the atomiser insert

- Open the atomiser **8** by twisting the top anticlockwise against the medication container **9**. Place the atomiser insert **10** in the medication container **9**.
- Ensure that the cone for administering medication fits well on the cone for channelling the air inside the atomiser **8**.

## 8.2 Filling the atomiser **C**

- Pour an isotonic saline solution or the medication directly into the medication container **9**. Avoid overfilling. The maximum recommended filling quantity is 6 ml.
- Use medication only as instructed by your doctor and ask about the appropriate inhalation period and quantity for you.
- If the prescribed quantity of medication is less than 2 ml, top this up to at least 2 ml with isotonic saline solution. Dilution is also necessary with viscous medications. Please observe the instructions of your doctor in this case, too.

## 8.3 Closing the atomiser

- Close the atomiser **8** by twisting the top clockwise against the medication container **9**. Ensure that the connection is correct.

## 8.4 Connecting the atomiser set to the atomiser

- Connect the atomiser **8** to the desired atomiser set (mouthpiece **12**, adult mask **13**, children's mask **14** or nosepiece **15**).

You can find an overview of all replacement items in the "Accessories and/or replacement parts" section.

### NOTICE

The most effective form of nebulisation is by using the mouthpiece. Nebulisation using a mask is only recommended if it is not possible to use a mouthpiece (e.g. for children who are not yet able to inhale using a mouthpiece).

If you are using the adult mask **13**, you can secure it to your head with the adult mask strap. There is also a strap for the children's mask **14**.

When using a mask to inhale, take care to ensure the mask fits well and the eyes are unobstructed.

- Before the treatment, pull the atomiser upwards out of the holder **4**.
- Start the nebuliser using the On/Off control **1**.
- Spray mist pouring out of the atomiser indicates that the device is operating correctly.

## 8.5 Treatment

- When inhaling, sit upright and relaxed at a table and not in an armchair to avoid compressing the airways and therefore impairing the effectiveness of the treatment.
- Breathe in the atomised medication deeply.

## **⚠ CAUTION**

The device is not suitable for continuous operation; after 30 minutes of operation it must be switched off for 30 minutes.

## **NOTICE**

During the treatment, hold the atomiser straight (vertically), otherwise the atomisation will not work and faultless functionality is not guaranteed.

Depending on the battery charge level and atomiser set used, the inhalation time stated may vary.

## **⚠ CAUTION**

Essential oils, cough syrups, gargling solutions and drops to be used as a rub or in a steam bath are wholly unsuitable for inhalation using a nebuliser. These additives are often viscous and can impair the correct functioning of the device and therefore the effectiveness of the application in the long term. For individuals with a hypersensitive bronchial system, medications containing essential oils may under certain conditions cause an acute bronchospasm (a sudden cramp-like restriction of the bronchi with shortness of breath). Talk to your doctor or pharmacist about this.

## **8.6 Stopping the inhalation**

Once the mist is only coming out in an irregular flow or if the sound changes when inhaling, you can stop the treatment.

- Switch off the nebuliser after treatment using the On/Off control **1** and disconnect it from the mains.
- Place the atomiser **8** back in its holder **4** after the treatment.

## **8.7 Cleaning**

See section "Cleaning and maintenance".

## **9. CHANGING THE FILTER**

In normal operating conditions, the air filter must be replaced after approx. 200 operating hours or one year. Please check the air filter regularly (after 10-12 nebulisation procedures). Replace the used filter if it is very dirty or clogged. If the filter has become damp, it must also be exchanged for a new filter.

## **⚠ CAUTION**

- Do not attempt to clean the used filter and reuse it.
- Only use the manufacturer's original filter, otherwise your nebuliser may become damaged and sufficiently effective treatment cannot be guaranteed.
- Do not repair or maintain the air filter while it is in use.
- Never operate the device without a filter.

To replace the filter, proceed as follows:

## **⚠ CAUTION**

- First switch the device off and disconnect it from the mains.
- Allow the device to cool down.

1. Pull off the filter cap **5** towards the front.  
**D**

## **NOTICE**

If the filter remains in the device after the cap has been removed, take the filter out of the device, e.g. with tweezers or similar.

2. Re-insert the filter cap **5** with a new filter.
3. Ensure that it is securely in place.

## 10. CLEANING AND MAINTENANCE

### Atomiser and atomiser set

#### **⚠ WARNING**

Follow these hygiene instructions to avoid health risks.

- The atomiser **8** and atomiser set are intended for multiple use. Please note that different areas of application involve different requirements in terms of cleaning and hygienic preparation.

#### **NOTICE**

- Do not clean the atomiser or the atomiser set mechanically using a brush or similar device, as this could cause irreparable damage and it will mean that the best treatment results can no longer be guaranteed.
- Please consult your doctor about the additional requirements in terms of the hygienic preparation needed (hand care, handling of medication/inhalation solutions) for high-risk groups (e.g. patients with cystic fibrosis).
- Ensure thorough drying after each cleaning or disinfection process. Residual moisture or wetness can represent an increased risk of bacterial growth.

#### **Preparation **C****

- Immediately after each treatment, all parts of the atomiser **8** and the atomiser set used must be cleaned of residual medication and contamination.
- To do this, dismantle the atomiser **8** into its individual parts.
- Remove the mouthpiece **12**, mask **13 14** or nosepiece **15** from the atomiser.
- Disassemble the nosepiece if you have used it with the comfort attachment.
- Dismantle the atomiser by twisting the top anticlockwise against the medication container **9**.

- Remove the atomiser insert **10** from the medication container **9**.
- Proceed in reverse order to subsequently reassemble the parts.

### Cleaning

#### **⚠ CAUTION**

The device must be switched off, disconnected from the mains and allowed to cool down each time before cleaning.

The **atomiser** and the **atomiser set** used such as the mouthpiece, mask, etc. must be washed with hot but not boiling water after each use. Dry the parts carefully using a soft cloth. Put the parts together again when they are completely dry and place them in a dry, sealed container or disinfect them.

When cleaning, ensure that any residue is removed. Never use any substances for cleaning that could potentially be toxic if they came into contact with the skin or mucous membranes, or if they were swallowed or inhaled.

Use a soft, dry cloth and non-abrasive cleaning products to clean the **device**.

Do not use any abrasive cleaning products and never submerge the device in water.

### Disinfection

#### **⚠ CAUTION**

Please observe the following points when disinfecting your atomiser **8** and the atomiser set. We recommend disinfecting the individual parts after the last treatment of the day as a minimum measure.

First, clean the atomiser **8** and atomiser set as described in the "Cleaning" section. The details of the disinfection method are listed below.

Parts	Boiling	Vinegar essence mixture
Atomiser	✓	✓
Mouthpiece	✓	✓
Nosepiece	✓	✓

Parts	Boiling	Vinegar essence mixture
Compressed air hose		✓
Masks		✓

Use only the method specified for each component.

Method of disinfection	Instructions
Boiling	Place the parts in question in boiling water for 5 minutes. Ideally, distilled water should be used to avoid contamination and limescale formation. The parts should not touch the hot base of the pan; you can use a heat-resistant sieve for this purpose.
Vinegar essence mixture	Place the parts in question in a container. Cover everything with a vinegar solution consisting of ½ vinegar essence (25% acidity) and ½ distilled water. Leave it to take effect for 30 minutes. Finally, clean all parts again with water.

### CAUTION

- Make sure that no water gets inside the device!
- Do not clean the device or atomiser set in the dishwasher!
- Do not touch the device with wet hands when it is plugged in and do not allow water to spray on the device. Only operate the device if it is completely dry.
- If liquid penetrates the device this could cause damage to the electronics or other nebuliser parts and lead to a malfunction.

## Condensation, hose care

Condensation may form in the hose depending on the ambient conditions. It is essential to remove the moisture to prevent bacterial growth and ensure proper treatment. To do so, proceed as follows:

- Disconnect the compressed air hose **7** from the atomiser **8**.
- The hose must remain in the nebuliser **6**.
- Operate the nebuliser until the moisture is removed by the air passing through.
- In the event of heavy contamination, replace the hose.

### CAUTION

- Do not boil or autoclave the compressed air hose or the masks.
- Put the parts together again when they are completely dry and place them in a dry, sealed container.

### NOTICE

- Please ensure that the parts are completely dried after cleaning, otherwise the risk of bacterial growth is increased.
- Use a cold disinfection solution in accordance with the manufacturer's instructions.

## Drying

- Place the individual parts on a clean, dry and absorbent surface and leave them to dry completely (at least 4 hours).

## Durability of materials

- As with any plastic parts, the atomiser and atomiser set are affected by a certain amount of wear and tear when used and hygienically prepared on a frequent basis. Over time, this can lead to a change in the aerosol, which can reduce the effectiveness of the treatment. We therefore recommend that you replace the atomiser and any atomiser set after a year.
- Observe the following when selecting the cleaning product or disinfectant: Only use

a mild cleaning product or disinfectant in the concentration and volume prescribed by the manufacturer.

## 12. WHAT IF THERE ARE PROBLEMS?

### Storage

- Do not store in damp conditions (such as in a bathroom) and do not transport with any damp items.
- When storing and transporting, protect from prolonged direct sunlight.
- The parts of the atomiser set can be securely stored in the storage bag for the atomiser set. Store the device in a dry place, ideally in the original packaging.

## 11. ACCESSORIES AND/OR REPLACEMENT PARTS

To purchase accessories and/or replacement parts, visit [www.beurer.com](http://www.beurer.com) or contact the corresponding service address (as per the service address list) for your country. Accessories and/or replacement parts are also available from retailers.

Designation (Material)	REF
Atomiser set (= year pack) (contains mouthpiece (PP), nosepiece (PP), adult mask (PVC), children's mask (PVC), atomiser (PC, PP), compressed air hose (PVC), filter (polyester cotton))	110.125
Mains adapter (5V/2A)	110.247

Problems/questions	Possible cause/remedy
The atomiser produces no or too little aerosol.	1. Too much or too little medication in the atomiser. Minimum: 2 ml, Maximum: 6 ml.
	2. Check nozzle for blockages. Clean nozzle if necessary (e.g. by rinsing out). Then start using the atomiser again. <b>IMPORTANT:</b> Carefully pierce the fine holes only from the underside of the nozzle.
	3. Atomiser not held vertically.
	4. Unsuitable medication fluid added for nebulisation (e.g. too viscous). The medication fluid should be prescribed by a doctor.
The output is too low.	Kinked hose, clogged filter, too much inhalation solution.
What medications are suitable for inhaling?	<b>Please consult your doctor in relation to this matter.</b> As a rule, all medication that is suitable and approved for device inhalation can be inhaled.
There is inhalation solution residue in the atomiser.	This is normal and is due to technical reasons. Stop inhalation once the atomiser starts to make a notably different sound.

Problems/questions	Possible cause/remedy
What should be taken into account when using the device with infants and children?	1. On infants and children, the mask should cover the mouth and nose to ensure effective inhalation.
	2. For children, the mask should also cover both the nose and mouth. It is not very useful to carry out nebulisation next to someone who is sleeping, as in this case not enough of the medication will reach the lungs.
	<b>Notice:</b> Inhalation should only be carried out under the supervision of an adult and with their assistance, and the child should not be left alone.
Inhalation using the mask takes longer.	This is due to technical reasons. You breathe in less medication per breath through the holes of the mask than via the mouthpiece. The aerosol is mixed with ambient air via the holes.

Problems/questions	Possible cause/remedy
Why should the atomiser be replaced regularly?	There are two reasons for this: <ol style="list-style-type: none"> <li>1. To ensure an appropriate particle spectrum for providing an effective treatment, the nozzle hole must not exceed a specific diameter. Due to mechanical and thermal stresses, the plastic is subject to a certain degree of wear. The atomiser insert <b>10</b> is particularly delicate. This can also alter the composition of the aerosol droplets, which directly affects the effectiveness of the treatment.</li> <li>2. Regularly changing the atomiser is also recommended for hygiene reasons.</li> </ol>
Should each person have their own atomiser?	Yes, this is absolutely essential for hygiene reasons.

## 13. DISPOSAL

### Disposal of the device

For environmental reasons, do not dispose of the device in household waste at the end of its service life.



Dispose of the device at a suitable local collection or recycling point in your country. Observe the local regulations for material disposal. Dispose of the device in accordance with EC Directive – WEEE (Waste Electrical and Electronic Equipment). If you have any questions, please contact the local authorities responsible for waste disposal. You can obtain the location of collection points for old devices from the local or municipal author-

ities, local waste disposal company or your dealer, for example.

## Battery replacement and disposal

1. To open the device, loosen the four screws on the underside of the device. **E1**
2. After removing the four screws on the underside, position the device so that you can read the Beurer lettering correctly on the side. In this position, remove the upper half of the housing. **E2**
3. After opening the device, you should see a plug connection into which the three cables enter. In the illustration, it is the left-hand, circled plug connection. This plug connection is connected to the battery via the cables. In the illustration, the battery is the elongated part on the left, on your device with a golden yellow top. **E3**
4. Disconnect this plug connection by pressing down on the front housing component (with the on/off switch) and pulling the plug connection upwards. **E4**
5. Remove the battery from the device. Dispose of the component properly, as described below. **E5**
6. To insert the new battery, carry out steps 1-5 in reverse order.
  - Insert the battery into the side of the device in the designated compartment. Contact Customer Service in order to purchase the battery to be installed.
  - Connect the new battery to the plug connection.
  - Place the upper housing part on the lower housing.
  - If the two housing parts are joined without a gap, turn the device over.
  - Refit the 4 screws on the underside.

The codes below are printed on batteries containing harmful substances:

Pb = battery contains lead

Cd = battery contains cadmium

Hg = battery contains mercury



## 14. TECHNICAL SPECIFICATIONS

Type	IH 60
Model	IH 61
Dimensions (W x H x D)	110 x 62 x 47 mm
Weight	0.222 kg
Operating pressure	Approx. 0.25 to 0.55 bar
Atomiser filling volume	Min. 2 ml Max. 6 ml
Medication flow rate	Approx. 0.25 ml/min
Sound pressure	Max. 48 dBA
Mains adapter power supply (not included in the delivery)	Input: 100–240 V~; 50–60 Hz; 0.5 A Output: 5 V  ; 2 A <input type="checkbox"/> Insulated/protection class 2
Mains adapter model no.	LXCP12X-050200BG
Manufacturer Mains adapter	Shenzhen Longxc Power Supply Co., Ltd.
Expected service life of the device	Information on the service life of the product can be found on the homepage

Empty, completely flat batteries must be disposed of in specially designated collection boxes, at recycling points or at electronics retailers. You are legally required to dispose of the batteries.

<p>Aerosol values according to EN ISO 27427: 2023 based on adult breathing patterns with sodium fluoride (NaF)</p>	<ul style="list-style-type: none"> <li>• Aerosol delivery: 0.15 ml</li> <li>• Aerosol delivery rate: 0.03 ml/min</li> <li>• Fill volume dispensed in percent per min.: 1.49%</li> <li>• Residual volume: 1.66 ml</li> <li>• Particle size (MMAD): <math>4.12 \pm 0.09 \mu\text{m}</math></li> <li>• GSD (geometrical standard deviation): <math>2.07 \pm 0.03</math></li> <li>• RF (respirable fraction &lt; 5 <math>\mu\text{m}</math>): <math>59.8 \pm 1.29\%</math></li> <li>• Large particle range (&gt;5 <math>\mu\text{m}</math>): 40.2%</li> <li>• Medium particle range (2 to 5 <math>\mu\text{m}</math>): <math>43.8 \pm 0.84\%</math></li> <li>• Small particle range (&lt;2 <math>\mu\text{m}</math>): <math>15.9 \pm 0.80\%</math></li> </ul>
<p>Operating conditions</p>	<p>Temperature: +10°C to +40°C          Relative humidity: 10% to 95%          Ambient pressure: 700 to 1060 hPa</p>
<p>Storage and transportation conditions</p>	<p>Temperature: -20°C to +60°C          Relative humidity: 10% to 95%</p>
<p><b>Battery:</b>          Capacity          Nominal voltage          Type designation</p>	<p>2570 mAh          3.7 V          Lithium-ion</p>

The serial number is located on the device or in the battery compartment.  
 Subject to technical changes.

## Particle size diagram

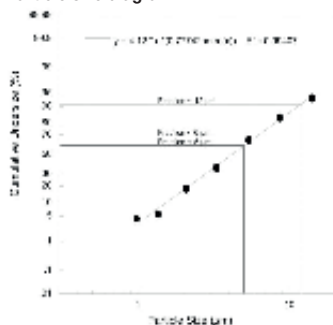

Measurements were performed using a sodium fluoride solution with a “Next Generation Impactor” (NGI). The diagram may, therefore, not be applicable to suspensions or highly viscous medications. You can obtain more detailed information from the manufacturer of your medication.

Aerosol values are based on adult breathing patterns and are likely to vary for paediatric or infant populations.

## NOTICE

If the device is not used according to the specifications, it may not work correctly! We reserve the right to make technical changes to improve and develop the product. This device and its atomiser set conform with the European standard EN 60601-1-2 (Group 1, class B, in accordance with CIS-PR 11, IEC 61000-3-2, IEC 61000-3-3, IEC 61000-4-2, IEC 61000-4-3, IEC 61000-4-4, IEC 61000-4-5, IEC 61000-4-6, IEC 61000-4-7, IEC 61000-4-8, IEC 61000-4-11) and are subject to particular precautions with regard to electromagnetic compatibility. Please note that portable and mobile HF communication systems may interfere with this device. For more details, please contact our Customer Services at the address indicated.

## **15. GUARANTEE / SERVICE**

More information on the guarantee and guarantee conditions can be found in the guarantee leaflet supplied.

### **Notification of incidents**

For users/patients in the European Union and identical regulation systems, the following applies: If a major incident occurs during or through use of the product, notify the manufacturer and/or their representative of this as well as the respective national authority of the member state in which you are located.



---

UK Importer: Beurer UK Ltd., Suite 16, Stonecross Place, Stonecross Lane  
North, WA3 2SH Lowton, United Kingdom



---

Beurer GmbH • Söflinger Str. 218 • 89077 Ulm, Germany  
[www.beurer.com](http://www.beurer.com) • [www.beurer-healthguide.com](http://www.beurer-healthguide.com)  
[www.beurer-gesundheitsratgeber.com](http://www.beurer-gesundheitsratgeber.com)

