

## GD655-5



Photos may show equipments not available in your area

### Motor grader

**Engine power**  
165 kW / 221 HP @ 2100 rpm

**Operating weight**  
15495 kg (with ripper 17425 kg)

**Blade length**  
3.71 m

# Walk-around



Engine power

**165 kW / 221 HP @ 2100 rpm**

Operating weight

**15495 kg (with ripper 17425 kg)**

Blade length

**3.71 m**

# High productivity, low fuel consumption and outstanding reliability

## Productivity

- Long wheelbase & short turning radius
- Optimized hydraulic & cooling system

## Control

- Outstanding power transmitting system

## Comfort

- Excellent visibility
- Spacious interior

## Serviceability

- Machine monitoring system
- Easy maintenance design

## Komtrax

- Energy saving operation report
- Equipment management support
- Optimal strategy for efficient work

## Ecology & economy

- Engine power mode selection system
- Circumference dynamic noise



# Dash 5 series motor graders



## The perfect fit for the jobsite

Most of motor grader applications requires accuracy and versatility. For that, motor graders should be easy to operate in any situations of work. To realize this ease of operation, Komatsu Dash 5 series motor graders are totally improved from overview design down to each element. Our design philosophy contributes to our motor graders fitting in every jobsites from road construction to snow removal, and brings more productivity to every operators from beginner to expert.

## Get more versatility

The GD655-5 attempts to get more versatility in the middle class graders which are used in various jobsites. With variety of work equipments and stretched wheelbase that is easier to accommodate longer blade, all elements are enhance job efficiency. Moreover, the torque converter transmission provides easy control, resulting in more precise operation in any application.



# Productivity



## Long wheelbase & short turning radius

The long wheelbase enables high leveling performance with a long blade and easier to set the blade position. Long wheelbase also contributes to expanding blade reach in combination with large articulation angle. Additionally the minimum turning radius still short with wide steering angle, serves high maneuverability.

## Optimized hydraulic & cooling system

### Control valve

Komatsu multifunctional control valve with Closed Load Sensing System (CLSS) Hydraulic System enable the constant cylinder speed, excellent multifunctional operation ability and fine control.

### 1) Low operating effort

Implement controls are designed to reduce operator fatigue. They feature short lever throws and effort in both directions. Properly spaced control levers and short lever throws allow the operator to use multiple controls with one hand.

### 2) Balanced flow

When the operator uses several controls at the same time, flow is proportional to ensure several implements can operate simultaneously.

### 3) Constant implement speed

Implement speed is constant regardless of engine speed because of the large pump output and proportional flow control function.

### Power on demand

Normally, the variable displacement pump idles at low output. When it senses a load requirement, the pump supplies quick flow and pressure to match the demand. The result is less hydraulic system heat, quick response and lower fuel consumption.

### Hydraulic cooling fan

The newly designed cooling fan eliminates excessive cooling capacity by controlling air flow rate according to work load.

# Control



## Outstanding power transmitting system

The GD655-5 features lock-up torque converter transmission for pursuing ease of operation. This unique system provides both efficiency of direct drive and controllability of torque converter drive. With this outstanding power transmitting system, the GD655-5 delivers advanced productivity in any applications from fine grading to heavy grading.

## Torque converter features

### High controllability

- Eliminates engine stalling and inching pedal operation
- Smooth starting, good controllability in fine grading
- Easy travelling, automatic gear shifting
- Reduce excessive tire slipping

### Torque multiplication

- Multiply over twice torque, provides much torque in heavy grading, ditching and ripping
- Stable engine speed, reduce shift changing during road maintenance and snow removal

### Lock-up function

- Prevents loss of efficiency

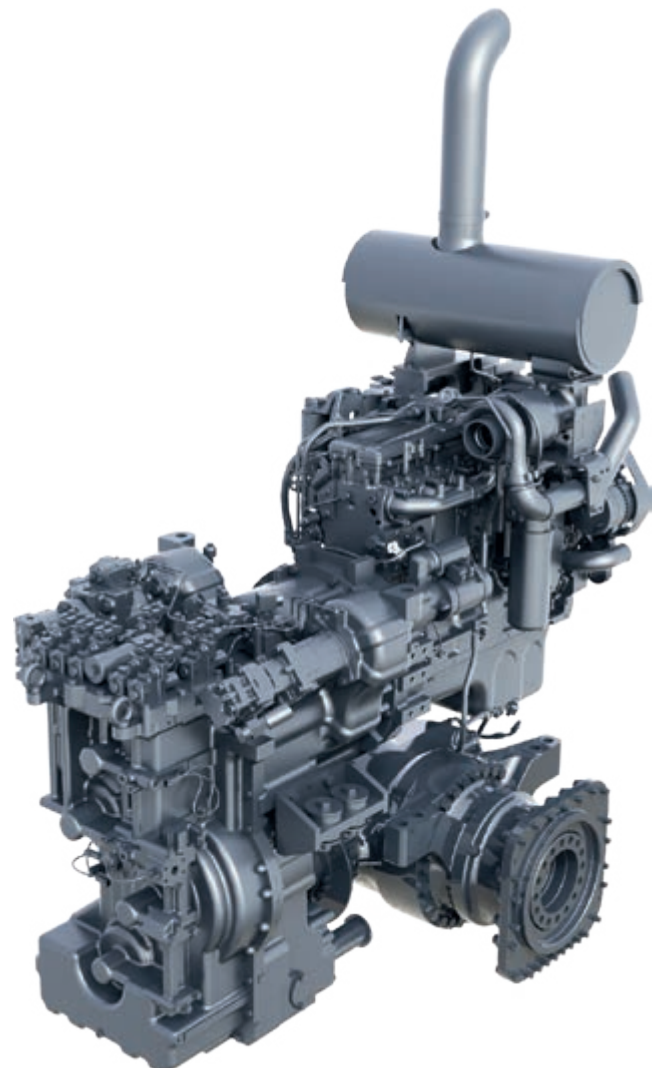

## Transmission mode selection

There are two transmission modes to enhance productivity. With the push of a button, transmission mode is selected to fit in working condition and preference of operators.

### Auto mode

Drive with torque converter in all shift position. This mode maximizes torque converter benefits. Lock-up will work in F5-F8 and R3-R4 position. Shifting F8 position serves automatic shifting through F4-F8 in response to machine speed.

### Manual mode

Works like the same way as conventional power shift, by engaging lock up clutch with all gears. This mode maximizes efficiency of direct shifting. In reverse travelling, works same way as Auto mode, serves less shift lever operation frequency.

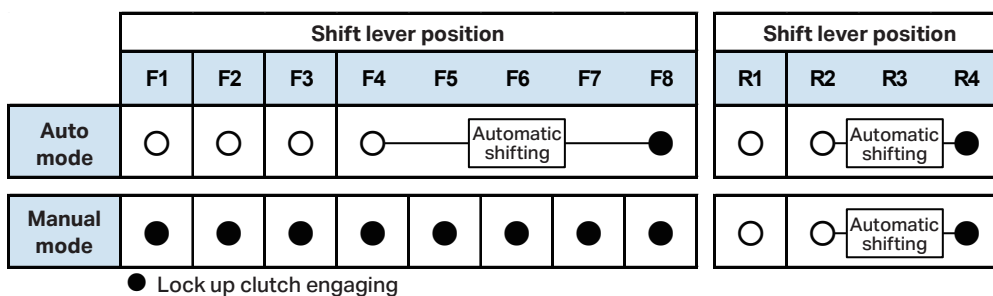

## Anti stall

Prevents engine stalling while lock up by automatically disengaging the lock up clutch and shifting to torque converter state. Torque converter provides much torque to continue to work as it is, never needs to restart the engine and shift the gear.

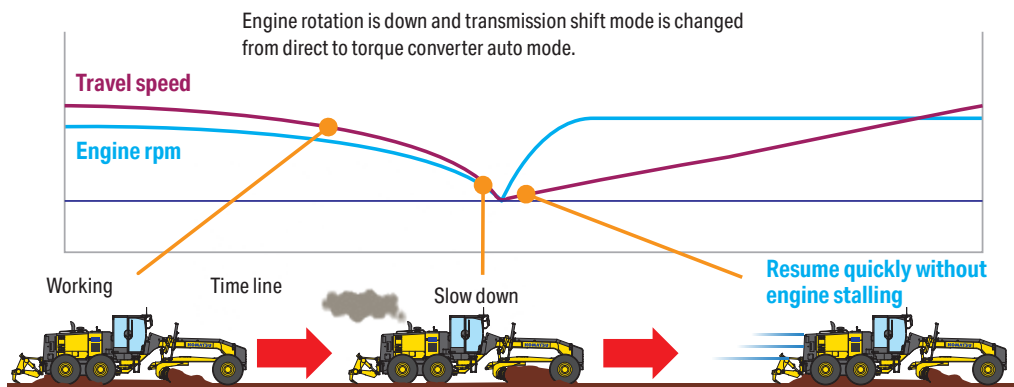

## Creep mode

Torque converter transmission introduces creep mode which provides constant low speed without acceleration and brake control. Optimized machine speed and great stability of torque converter boosts up precise control during fine grading.

## Power train protection

Electronic over-speed protection prevents downshifting until reducing the travel speed to the safe range of shift changing. FR inhibitor restricts excessive shuttle shifting at high traveling speed.

## Reduce shift shock for driving comfort

Torque converter allows to absorb torque fluctuation of the engine. Even in shifting the gear during lock up, torque converter temporarily absorb shift shock and contributes high driving comfort.

# Comfort



## Excellent visibility

Excellent visibility by hexangular cab with front Y shape pillar and rear layout side pillar boost operator's confidence and productivity in all grader applications. Well-positioned blade linkage provides an unobstructed view of the moldboard and front tires. The tapered engine hood provides good visibility to the rear of the machine, especially the rear ripper.

## ROPS cab



Low profile cab is designed to ensure ROPS/FOPS (ISO 3471/ISO 3449) certification.



Rear (ripper) view from the cab



## Spacious interior

### Low noise

New hydraulically driven fan and redesigned layout of the cooling system achieve a low noise level.

**Operator's ear dynamic noise level (ISO 6396) 74 dB(A)**

### Suspension seat

The suspension, fabric covered seat which is adjustable to the operator's weight is provided as standard. The suspension seat dampens vibrations transmitted from the machine and reduces operator fatigue. The seat features fold-up armrests and a retractable seat belt.



### Air conditioner

Well-positioned air conditioning vents keep the operator comfortable through a wide range of outside conditions.



### Electric throttle control

The RPM mode select switch allows the operator to perfectly match the working condition by selecting between three modes: Auto, Off and Manual. The engine speed set by throttle switch is temporarily cancelled when operating the brake/acceleration pedal at Auto mode.



### Storage space

The cab includes built-in storage space for personal items such as a lunch box, coffee cup, and a coat hook.



### Adopted DC 12 V electrical outlet (Optional)

12 V DC outlets is included in the operator's cab.

### Adjustable control console

The control console is adjustable backward and forward to facilitate entry and exit from the cab. The steering wheel also tilts to the operators preference.

# Serviceability

## Machine monitoring system

The machine monitor displays various machine information and allows for various settings of the machine. Displays maintenance information, operation records, etc. By using the switch panel, you can display various user menus on the Liquid Crystal Display (LCD) unit screen and perform the settings of the machine.

## Clear character display

During normal operation, the service meter/odometer is displayed in this area. If an abnormality or machine overload occurs, or if machine maintenance and inspection are required, action codes appear on the display to allow the operator to take appropriate action.

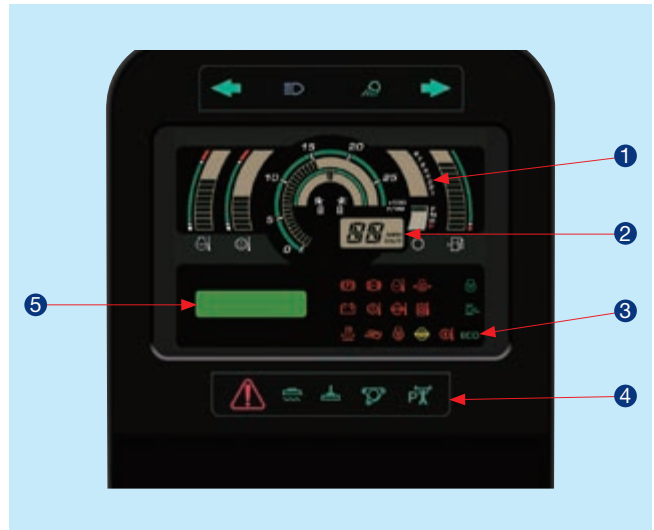

- ① Gear position
- ② Speed meter
- ③ ECO indicator
- ④ Power mode indicator
- ⑤ Character display
  - Service meter
  - Odometer
  - Maintenance information
  - Error code
  - Fuel consumption information

## Easy maintenance design

### Accessibility to service areas

- Easy and more safety refueling from the ground
- Large hinged service door serves wide inspection area
- Service meter is integrated with the machine monitor
- Distinguishable fuse panel in the cab
- Tandem oil check points is easy to access
- Spin-on filters for quick replacing
- Oil drains located near ground

### Power train components

With a modular design, you can remove the engine, transmission or final drives independently for quick service.

### Disconnect switch

For inspection and maintenance, the batteries can be disconnected with this switch when repairing the machine or checking batteries.



Ground refueling



Tool box

# Komtrax



The Komatsu remote monitoring and management technology provides insightful data about your equipment and fleet in user-friendly format.

## Energy saving operation report

Komtrax delivers the energy-saving operation report based on the operating information such as fuel consumption, load summary and idling time, which helps you efficiently run a business.



This report image is an example of hydraulic excavator

## Equipment management support

Through the web application, a variety of search parameters are available to quickly find information about specific machines based on key factors. Moreover, Komtrax finds out machines with problems from your fleet and shows you through an optimal interface.

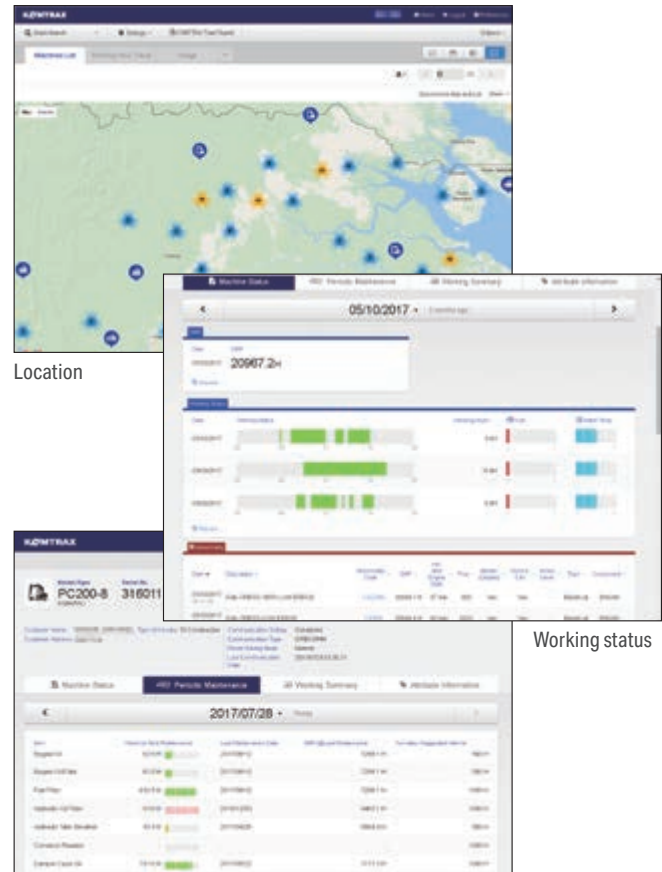

Location

Working status

Periodic maintenance

The report contents and data depend on the machine model.

## Optimal strategy for efficient work

The detailed information that Komtrax puts at your fingertips helps you manage your fleet conveniently on the web anytime, anywhere. It gives you the power to make better daily and long-term strategic decisions.

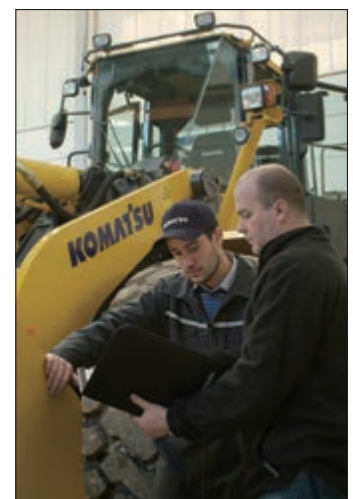

# Ecology & economy



## Engine power mode selection system

The system allows selection of the appropriate mode between two modes E or P mode according to each working condition. The mode is easily selected with a switch in the operator's cab.

### • P mode

Greater productivity can be attained by taking full advantage of high output power. It is appropriate for job sites where the motor grader meets high resistance.

### • E mode

This mode is selected for maximum economy and lighter work applications. This feature provides the appropriate power and better fuel consumption.

## Komatsu technology



Komatsu uniquely develops all major components including total control system, like engines, electronics, and hydraulic components. With this "Komatsu technology" and continuous customer feedback, Komatsu has been achieving great advancements of technology. This resulted in new generation of high performance and environmentally friendly products.



## High performance engine

Powerful turbocharged and air-to-air aftercooled Komatsu SAA6D107E-1 engine provides 163 kW 218 HP. This engine realizes high power with low fuel consumption by Common Rail Injection system (CRI), and thus it delivers higher work speeds with high horsepower. In addition, high torque at low speed, impressive acceleration, and low fuel consumption ensure maximum productivity. This engine is U.S. EPA Tier 3 and EU Stage 3A emissions certified.

unit: kW(HP)

	P mode		E mode	
	AUTO	MANU.	AUTO	MANU.
F1	134 (180)	134 (180)	108 (145)	108 (145)
F2				
F3	149 (200)	149 (200)	134 (180)	134 (180)
F4				
F5				
F6				
F7	163 (218)	163 (218)	149 (200)	149 (200)
F8				
R1	134 (180)	134 (180)	108 (145)	108 (145)
R2				
R3	149 (200)	149 (200)	134 (180)	134 (180)
R4				

### Circumference dynamic noise

The dynamic circumference noise is lowered by various kind of countermeasures like the hydraulic driven cooling fan, the variable displacement pump and etc.

---



---

**Circumference dynamic noise level (ISO 6395) 111.4 dB(A)**

---



---



Hydraulic driven cooling fan

### Double seal cylinder (Blade side shift cylinder)

A double-seal design is used for the blade side shift cylinder, which is installed near the ground, and thus susceptible to damage by dirt. Environmentally friendly by preventing oil leakage from the cylinder.

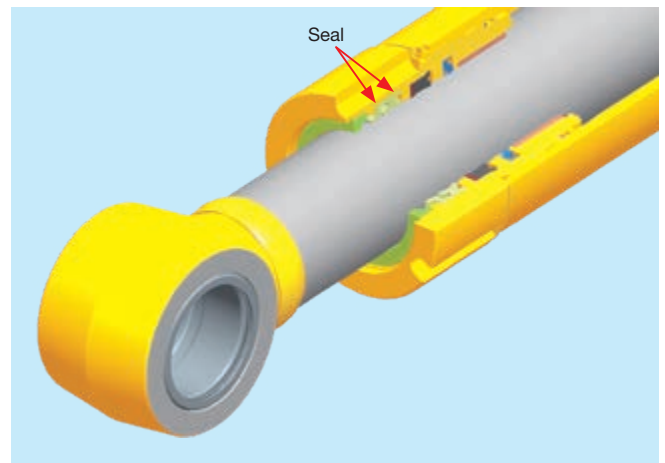

# Work equipment



## Komatsu genuine work equipment

### Moldboard options

Available both 3.7 m (12 ft) and 4.3 m (14 ft) moldboards. Optional thicker blades are also available for heavy duty application.

### Front blade

The front blade is a front mounted equipment used for spreading materials such as gravel piles or blading at the front of the machine where is difficult to access with the moldboard.

### Ripper and scarifier

Digs up hard material cannot be removed by the moldboard. The scarifier can accommodate up to 11 teeth, the ripper also accommodate up to 5 shanks and 9 scarifier teeth.



# Komatsu total support



## Komatsu total support

To keep your machine available and minimize operation cost when you need it, the Komatsu distributor is ready to provide variety of support before and after procuring the machine.

### Fleet recommendation

The Komatsu distributor can study customer job site and provide the most optimum fleet recommendation with detailed information to meet all of your application needs when you are considering to buy new machines or to replace the existing ones from Komatsu.



### Product support

The Komatsu distributor secure the certain quality of machine will be delivered.

### Parts availability

The Komatsu distributor is available for emergency inquiry by the customers for genuine, quality guaranteed Komatsu parts.

### Technical support

Komatsu product support service (technical support) are designed to help customer. Komatsu distributor offers a variety of effective services how much Komatsu is dedicated to the maintenance and support of Komatsu machine.

- Preventive Maintenance (PM) clinic
- Oil & wear analysis program

### Repair & maintenance service

The Komatsu distributor offers quality repair service, periodical maintenance, and maintenance service to the customer, utilizing and promoting Komatsu developed programs.

### Komatsu Reman (Remanufactured) components

Komatsu Reman products are the result of the implementation of the Komatsu global Reman policy which establishes and agrees to reduce the owning, operating and total Life Cycle Costs (LCC) to Komatsu's customer through prompt delivery, high quality and competitively priced in own remanufactured products (QDC).



# Specifications



## Engine

Model ..... KOMATSU SAA6D107E-1  
 Type ..... Water-cooled, 4-cycle, direct injection  
 Aspiration ..... Turbocharged and air to air aftercooled  
 Number of cylinders ..... 6  
 Bore ..... 107 mm  
 Stroke ..... 124 mm  
 Piston displacement ..... 6.69 l  
 Gross horsepower (Manual mode)  
 P-mode  
 Gear 1-3 ..... 136 kW / 183 HP / 2000 rpm  
 Gear 4-6 ..... 151 kW / 203 HP / 2000 rpm  
 Gear 7-8 ..... 165 kW / 221 HP / 2000 rpm  
 E-mode  
 Gear 1-3 ..... 110 kW / 148 HP / 2000 rpm  
 Gear 4-6 ..... 136 kW / 183 HP / 2000 rpm  
 Gear 7-8 ..... 151 kW / 203 HP / 2000 rpm  
 Net flywheel horsepower\* (Manual mode)  
 P-mode  
 Gear 1-3 ..... 134 kW / 180 HP / 2000 rpm  
 Gear 4-6 ..... 149 kW / 200 HP / 2000 rpm  
 Gear 7-8 ..... 163 kW / 218 HP / 2000 rpm  
 E-mode  
 Gear 1-3 ..... 108 kW / 145 HP / 2000 rpm  
 Gear 4-6 ..... 134 kW / 180 HP / 2000 rpm  
 Gear 7-8 ..... 149 kW / 200 HP / 2000 rpm  
 Maximum torque ..... 941 Nm / 96.0 kgfm / 1450 rpm  
 Torque rise ..... 31%  
 Fan speed ..... Max. 1500 rpm  
 Air cleaner ..... 2-stage, dry-type  
 Electrical ..... 24 V with 60 A alternator  
 Battery ..... 2, low maintenance plus, 12 V, 1146 cca

\*: Net horsepower output for standard (SAE J1349) including air cleaner, alternator (not charging), water pump, lubricating oil, fuel pump, muffler and fan running at minimum speed. EPA Tier 3 and EU Stage 3A emissions certified.



## Transmission and torque converter

Full power shift transmission with integral free wheeling stator torque converter and lock-up.

### Speeds (at rated engine speed)

Gear	Forward	Reverse
1st	3.4 km/h	4.5 km/h
2nd	5.0 km/h	9.2 km/h
3rd	7.0 km/h	20.3 km/h
4th	10.2 km/h	40.3 km/h
5th	15.4 km/h	—
6th	22.3 km/h	—
7th	30.6 km/h	—
8th	44.3 km/h	—



## Tandem drive

Oscillating welded box section ..... 520 mm × 202 mm  
 Side wall thickness: Inner ..... 22 mm  
 Outer ..... 19 mm  
 Wheel axle spacing ..... 1525 mm  
 Tandem oscillation ..... 11° forward, 13° reverse



## Front axle

Type ..... Solid bar construction welded steel sections  
 Ground clearance at pivot ..... 620 mm  
 Wheel lean angle, right or left ..... 16°  
 Oscillation, total ..... 32°



## Rear axle

Alloy steel, heat treated, full floating axle with lock/unlock differential.



## Steering

Hydraulic power steering providing stopped engine steering meeting ISO 5010.  
 Minimum turning radius ..... 7.4 m  
 Maximum steering range, right or left ..... 49°  
 Articulation ..... 25°



## Brakes

Service brake ..... Foot operated, sealed oil disc brakes, hydraulically actuated on four tandem wheels, 13691 cm<sup>2</sup> total braking surface.  
 Parking brake ..... Manually actuated, spring applied, hydraulically released caliper.



## Frame

Front frame structure  
 Height ..... 300 mm  
 Width ..... 300 mm  
 Side ..... 14 mm  
 Upper, lower ..... 25 mm



## Drawbar

A-shaped, u-section press formed and welded construction for maximum strength with a replaceable drawbar ball.  
 Drawbar frame ..... 210 mm × 25 mm



## Circle

Single piece rolled ring forging. Four circle support shoes with replaceable wear surface. Circle teeth hardened on front 180° of circle.  
 Diameter (outside) ..... 1530 mm  
 Circle reversing control hydraulic rotation ..... 360°





## Moldboard

Hydraulic power shift fabricated from high carbon steel. Includes replaceable metal wear inserts, cutting edge and end bits.

Cutting edge and end bits are hardened.

Dimensions . . . . . 3710 mm × 645 mm × 19 mm

Arc radius . . . . . 329 mm

Cutting edge . . . . . 152 mm × 16 mm

Blade pull

Base GVW . . . . . 9030 kgf

With scarifier GVW . . . . . 9095 kgf

With ripper GVW . . . . . 9910 kgf

Blade down pressure

Base GVW . . . . . 6985 kgf

With scarifier GVW . . . . . 7925 kgf

With ripper GVW . . . . . 8375 kgf



## Blade range

Circle center shift:

Right . . . . . 590 mm

Left . . . . . 550 mm

Moldboard side shift:

Right . . . . . 820 mm

Left . . . . . 820 mm

Maximum shoulder reach outside rear tires (frame straight)

Right . . . . . 2000 mm

Left . . . . . 2000 mm

Maximum lift above ground . . . . . 505 mm

Maximum cutting depth . . . . . 815 mm

Maximum blade angle, right or left . . . . . 90°

Blade tip angle . . . . . 40° forward, 5° backward



## Hydraulics

Load-sensing closed center hydraulics with variable displacement piston pump. Short stroke/low effort direct acting control valves with preselected maximum flow setting to each function. Double acting anti-drift check valves on blade lift, tip, circle shift, articulation, and leaning wheels.

Output (at engine rated rpm) . . . . . 200 l/min

Standby pressure . . . . . 3.4 MPa / 35 kgf/cm<sup>2</sup>

Maximum system pressure . . . . . 20.6 MPa / 250 kgf/cm<sup>2</sup>



## Instruments

Electric monitoring system with diagnostics:

Gauges:

Standard . . . . . Articulation, engine coolant temperature, fuel level, speed meter, T/M shift indicator, engine tachometer torque converter oil temperature

Warning lights/Indicator:

Standard . . . . . Battery charge, brake oil pressure, inching temperature, directional indicator, engine oil pressure, hydraulic oil temperature, heater signal, lift arm lock, parking brake, differential lock, torque converter oil temperature, ECO, P mode, rpm set, high beam, working lights

Optional . . . . . Blade accumulator



## Capacities (refilling)

Fuel tank . . . . . 416 l

Cooling system . . . . . 24.9 l

Crank case . . . . . 23.1 l

Transmission . . . . . 45 l

Final drive . . . . . 17 l

Tandem housing (each) . . . . . 57 l

Hydraulic system . . . . . 69 l

Circle reverse housing . . . . . 7 l



## Operating weight (approx.)

Includes lubricants, coolant, full fuel tank

Total . . . . . 15495 kg

On rear wheels . . . . . 11290 kg

On front wheels . . . . . 4025 kg

With front mounted scarifier:

Total . . . . . 16140 kg

On rear wheels . . . . . 11370 kg

On front wheels . . . . . 4770 kg

With rear mounted ripper and front push plate:

Total . . . . . 17425 kg

On rear wheels . . . . . 12385 kg

On front wheels . . . . . 5040 kg



## Scarifier (optional)

Middle, V-type

Working width . . . . . 1430 mm

Scarifying depth, maximum . . . . . 210 mm

Scarifier shank holders . . . . . 11

Scarifier shank holders spacing . . . . . 138 mm

Rear

Working width . . . . . 2186 mm

Scarifying depth, maximum . . . . . 165 mm

Scarifier shank holders . . . . . 9

Scarifier shank holders spacing . . . . . 267 mm



## Ripper (optional)

Ripping depth, maximum . . . . . 425 mm

Ripper shank holders . . . . . 5

Ripper shank holder spacing . . . . . 534 mm

Penetration force . . . . . 8665 kgf

Pry out force . . . . . 13335 kgf

Machine length increase, beam raised . . . . . 765 mm



## Dimensions

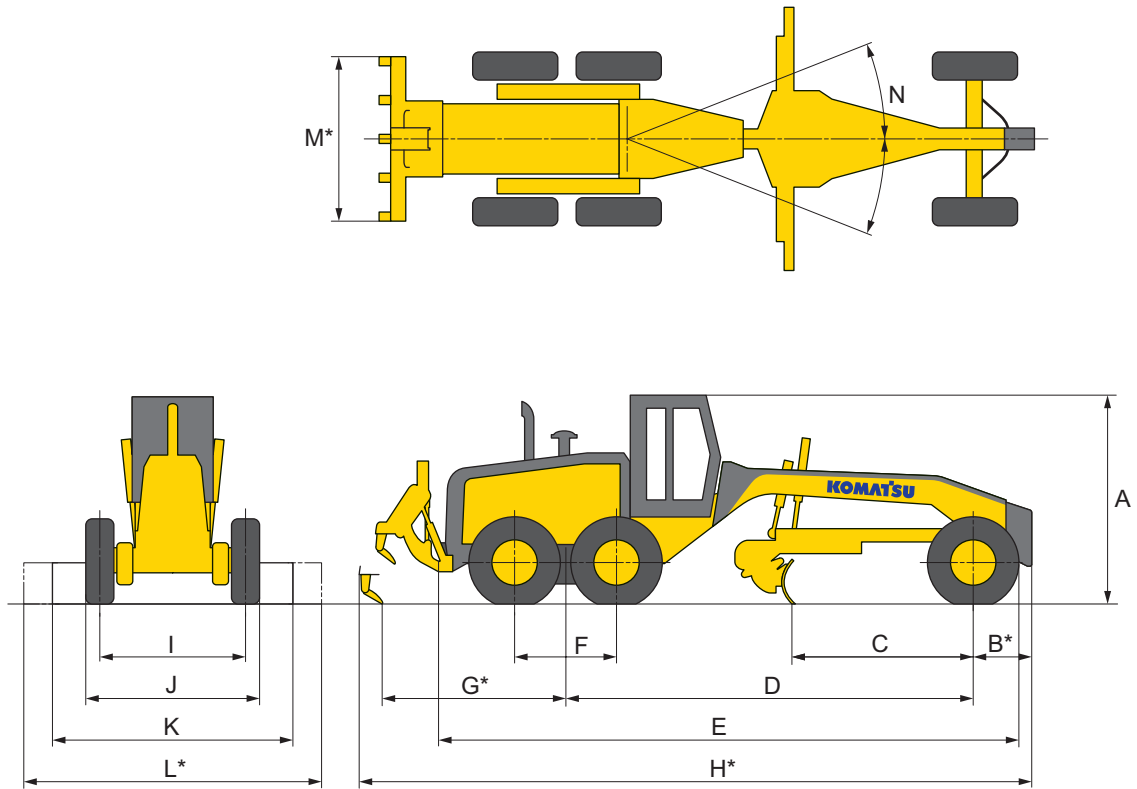

A	Height: low profile cab	3200 mm
B*	Center of front axle to counterweight (pusher)	927 mm
C	Cutting edge to center of front axle	2580 mm
D	Wheel base to center of tandem	6480 mm
E	Front tire to rear bumper	9205 mm
F	Tandem wheelbase	1525 mm
G*	Center of tandem to back of ripper	2780 mm
H*	Overall length	10575 mm
I	Track of gauge	2060 mm
J	Width of tires	2485 mm
K	Width of standard moldboard	3710 mm
L*	Width of optional moldboard	4320 mm
M*	Ripper beam width	2305 mm
N	Articulation, left or right	25°

\*optional



## Wheels, front and rear

Tire	Rim size	Rim structure
14.00-24	9"	Single-piece
14.00R24	9"	Single-piece
14.00R24	10"	Multi-piece
17.5R25	13"	Single-piece
17.5R25	14"	Multi-piece



## Standard equipment

### Engine and related items

- Double element air cleaner and dust indicator.
- Engine: Komatsu SAA6D107E-1, turbocharged and air-to-air aftercooled, standard variable horse power control, 145-218 HP net horsepower
- Cooling fan, hydraulic driven with reverse
- Fuel line pre-filter
- Hood-sides for engine compartment
- Air intake extension

### Electrical systems

- Alarm, back-up
- Alternator 24 V/60 A
- Battery, extreme duty, 1146 cca each
- Dome light, cab
- Horn, electric
- Lights: back-up, stop, tail, directional, headlights (2 halogen type, front bar mounted)
- Work lamps: front (4), rear (2)
- Speedometer
- Indicators: parking brake, differential lock, blade float, lift arm lock, high beam, ECO, engine P mode, cooling fan reverse, rpm set, engine oil pressure, battery charge, brake oil pressure, differential oil temperature

### Operator environment

- Cab: low profile enclosed ROPS/FOPS (ISO 3471/ ISO 3449) with safety tinted glass windows with wiper and washer
- Air conditioner (R134a)
- Console, adjustable with instrument panel monitoring system
- Mirrors: interior cab, right and left exterior mirrors
- Seat, deluxe adjustable cloth with retractable seat belt
- Sound suppression, cab and floor mat
- Wipers, front, doors, and rear
- 12 V (10 A) power port

### Power train

- Dual mode transmission (8F-4R) power shift, direct drive and torque converter with auto shift
- Axle, rear full floating, planetary type
- Service brakes, fully hydraulic wet disc
- Brake, parking, spring applied, hydraulic release, disc type
- Differential, lock/unlock

### Work equipment and hydraulics

- Circle, drawbar mounted, 360° rotation hydraulic blade lift and circle side shift
- Circle slip clutch
- Hydraulic system, closed center, load sensing
- Moldboard: 3710 mm × 645 mm × 19 mm with replaceable end bits, through-hardened cutting edges 152 mm × 16 mm, hydraulic blade side shift and hydraulic tilt with anti-drift check valves. Maximum moldboard angle position 90° right & left
- Steering, full hydraulic with tilt steering wheel plus leaning front wheels and frame articulation w/ anti-drift check valves
- 9 section hydraulic control valve
- Blade lift float detent style, LH and RH

### Other standard equipment

- Painting, Komatsu standard color scheme
- Steps and handrails, rear, right, and left side
- Vandalism protection includes lockable access to fuel tank, battery cover, and engine side covers
- Tool box with lock
- Fuel tank, ground level access
- Battery disconnect switch



## Optional equipment

- Accumulators, anti-shock for blade lift
- 10 section hydraulic control valve
- Cab mount work lamps (4)
- General toolkit
- Pre-cleaner, Turbo II
- Pusher plate, additional
- Additional heater
- AM/FM radio
- Moldboard, 3710 mm × 645 mm × 25 mm
- Moldboard, 4320 mm × 645 mm × 19 mm
- Moldboard, 4320 mm × 645 mm × 25 mm with replaceable end bits, through-hardened cutting edges 152 mm × 16 mm
- Front blade
- Ripper, assembly, rear mounted
- Ripper shanks and points, 2 additional
- Scarifier, assembly, 11-shank type
- Scarifier, shanks and points (9) for ripper
- Warning light, amber colored rotating beacon, cab roof mounted
- Alternator, 24 V/90 A

Standard equipment may vary for each country, and this specification sheet may contain attachments and optional equipment that are not available in your area. Up to 20% blended biodiesel fuel and paraffine fuel can be used. Please consult your Komatsu distributor for detailed information.

---

Your Komatsu partner:

**KOMATSU**

[komatsu.com](https://www.komatsu.com)