

KOMATSU

GD755-5R



Photos may show equipments not available in your area

Motor grader

Engine power
216 kW / 290 HP @ 2000 rpm

Operating weight
21650 kg (with ripper 24380 kg)

Blade length
4.32 m

Walk-around



Engine power

216 kW / 290 HP @ 2000 rpm

Operating weight

21650 kg (with ripper 24380 kg)

Blade length

4.32 m

High productivity, low fuel consumption and outstanding reliability

Productivity

- Long wheelbase & short turning radius
- Job proven Komatsu power train
- Ideal weight distribution
- Reinforced structure

Control

- Outstanding power transmitting system

Comfort

- Excellent visibility
- Spacious interior

Serviceability

- Machine monitoring system
- Easy maintenance design

Komtrax

- Energy saving operation report
- Equipment management support
- Optimal strategy for efficient work

Ecology & economy

- Engine power mode selection system
- Circumference dynamic noise



Dash 5 series motor graders



The perfect fit for the jobsite

Most of motor grader applications requires accuracy and versatility. For that, motor graders should be easy to operate in any situations of work. To realize this ease of operation, Komatsu Dash 5 series motor graders are totally improved from overview design down to each element. Our design philosophy contributes to our motor graders fitting in every jobsites from road construction to snow removal, and brings more productivity to every operators from beginner to expert.

More productivity to the large size graders

The GD755-5R is designed as pursuing high productivity in Komatsu 14 ft graders. Optimal machine balance serves great working stability even in heavy blading. By improving cooling efficiency and reducing hydraulic pressure loss, the GD755-5R delivers high production efficiency while keeping high production volumes.



Productivity

Job proven Komatsu power train

All components cooperate mutually for maximizing productivity of the motor grader. The in-house manufacturing of main components including power train optimizes entire machine system. Also, from over the years of Komatsu motor grader development, practical experience of jobsite serves solid reliability.

Ideal weight distribution

By laying out the transmission to the center of the machine, ideal weight distribution contributes great controllability to operators.



Reinforced structure

The rear frame is designed to improve reliability while ripping operation. Reinforced welded structure of circle support enhances durability for heavy load digging and spreading operation. The circle and pinion gear are increased gear module to resist wear. The circle is also surely retained with six circle guide shoe.

Long wheelbase & short turning radius

The long wheelbase enables high leveling performance with a long blade and easier to set the blade position. Long wheelbase also contributes to expanding blade reach in combination with large articulation angle. Additionally the minimum turning radius still short with wide steering angle, serves high maneuverability.

Optimized hydraulic & cooling system

Control valve

Komatsu multifunctional control valve with Closed Load Sensing System (CLSS) hydraulic system enable the constant cylinder speed, excellent multifunctional operation ability and fine control.

1) Low operating effort

Implement controls are designed to reduce operator fatigue. They feature short lever throws and effort in both directions. Properly spaced control levers and short lever throws allow the operator to use multiple controls with one hand.

2) Balanced flow

When the operator uses several controls at the same time, flow is proportional to ensure several implements can operate simultaneously.

3) Constant implement speed

Implement speed is constant regardless of engine speed because of the large pump output and proportional flow control function.

Power on demand

Normally, the variable displacement pump idles at low output. When it senses a load requirement, the pump supplies quick flow and pressure to match the demand. The result is less hydraulic system heat, quick response and lower fuel consumption.

Hydraulic cooling fan

The newly designed cooling fan eliminates excessive cooling capacity by controlling air flow rate according to work load.

Control



Outstanding power transmitting system

The GD755-5R features lock-up torque converter transmission for pursuing ease of operation. This unique system provides both efficiency of direct drive and controllability of torque converter drive. With this outstanding power transmitting system, the GD755-5R delivers advanced productivity in any applications from fine grading to heavy grading.

Torque converter features

High controllability

- Eliminates engine stalling and inching pedal operation
- Smooth starting, good controllability in fine grading
- Easy travelling, automatic gear shifting
- Reduce excessive tire slipping

Torque multiplication

- Multiply over twice torque, provides much torque in heavy grading, ditching and ripping
- Stable engine speed, reduce shift changing during road maintenance and snow removal

Lock-up function

- Prevents loss of efficiency

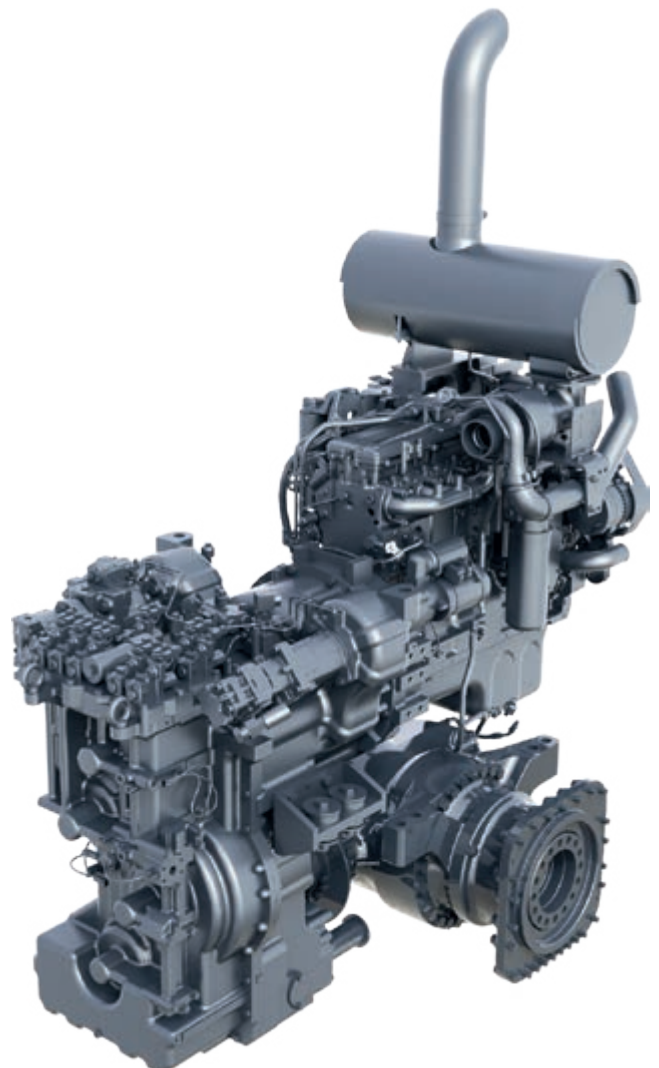

Transmission mode selection

There are two transmission modes to enhance productivity. With the push of a button, transmission mode is selected to fit in working condition and preference of operators.

Auto mode

Drive with torque converter in all shift position. This mode maximizes torque converter benefits. Lock-up will work in F5-F8 and R3-R4 position. Shifting F8 position serves automatic shifting through F4-F8 in response to machine speed.

Manual mode

Works like a same way as conventional power shift, by engaging lock up clutch with all gears. This mode maximizes efficiency of direct shifting. In reverse travelling, works same way as Auto mode, serves less shift lever operation frequency.

	Shift lever position								Shift lever position				
	F1	F2	F3	F4	F5	F6	F7	F8	R1	R2	R3	R4	
Auto mode	○	○	○	○	Automatic shifting				●	○	○	○	*
Manual mode	●	●	●	●	●	●	●	●	●	●	●	●	*

● Lock up clutch engaging * Automatic shifting up to 8th gear

Anti stall

Prevents engine stalling while lock up by automatically disengaging the lock up clutch and shifting to torque converter state. Torque converter provides much torque to continue to work as it is, never needs to restart the engine and shift the gear.

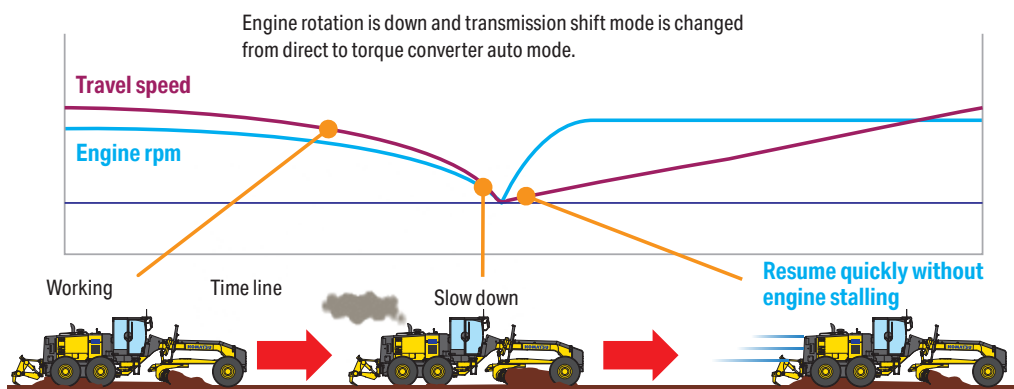

Creep mode

Torque converter transmission introduces creep mode which provides constant low speed without acceleration and brake control. Optimized machine speed and great stability of torque converter boosts up precise control during fine grading.

Power train protection

Electronic over-speed protection prevents downshifting until reducing the travel speed to the safe range of shift changing. FR inhibitor restricts excessive shuttle shifting at high traveling speed.

Reduce shift shock for driving comfort

Torque converter allows to absorb torque fluctuation of the engine. Even in shifting the gear during lock up, torque converter temporarily absorb shift shock and contributes high driving comfort.

Comfort



Excellent visibility from cab

Excellent visibility

Exceptional visibility by quadrangle cab with front pillar and rear layout side pillar boost operator's confidence and productivity in all grader applications. Well-positioned blade linkage provides an unobstructed view of the moldboard and front tires. The tapered engine hood provides good visibility to the rear of the machine, especially the rear ripper.



Spacious interior



Roomy interior

Extra leg and foot room create a spacious, open cab. The cab includes built-in storage space for personal items such as a lunch box, cup holder, and a coat hook.

Suspension seat

The seat features fold-up armrests and a retractable seat belt. The seat follows the contour of the body and can be easily adjusted for optimal support and comfort.

Electric throttle control

The RPM mode select switch allows the operator to perfectly match the working condition by selecting between three modes: Auto, Off and Manual. The engine speed set by throttle switch is temporarily cancelled when operating the brake/acceleration pedal at Auto mode.

Electronic monitoring system

Electronic monitoring system monitors important machine systems and provides the operator with a warning if an abnormality occurs.

Low operating noise

By changing the location of the equipments, the dynamic noise is lowered drastically compared with the GD705A-4.

Adjustable control console

The control console is adjustable backward and forward to facilitate entry and exit from the cab. The steering wheel also tilts to the operators preference.

Air conditioner (A/C)

Well-positioned air conditioning vents keep the operator comfortable through a wide range of outside conditions.

Safety

Cab is low profile enclosed ROPS/FOPS (ISO 3471 / ISO 3449).



ROPS (ISO 3471) cab
(Equipped with defroster and intermittent wiper)

Serviceability

Machine monitoring system

The machine monitor displays various machine information and allows for various settings of the machine. Displays maintenance information, operation records, etc. By using the switch panel, you can display various user menus on the Liquid Crystal Display (LCD) unit screen and perform the settings of the machine.

Clear character display

During normal operation, the service meter/odometer is displayed in this area. If an abnormality or machine overload occurs, or if machine maintenance and inspection are required, action codes appear on the display to allow the operator to take appropriate action.



- ① Gear position
- ② Speed meter
- ③ ECO indicator
- ④ Power mode indicator
- ⑤ Character display
 - Service meter
 - Odometer
 - Maintenance information
 - Error code
 - Fuel consumption information

Easy maintenance design

Accessibility to service areas

- Easy and more safety refueling from the ground
- Large hinged service door serves wide inspection area
- Service meter is integrated with the machine monitor
- Distinguishable fuse panel in the cab
- Tandem oil check points is easy to access
- Spin-on filters for quick replacing
- Oil drains located near ground

Power train components

With a modular design, you can remove the engine, transmission or final drives independently for quick service.

Disconnect switch (optional)

For inspection and maintenance, the batteries can be disconnected with this switch when repairing the machine or checking batteries.



Ground refueling



Tool box

Komtrax

KOMTRAX

The Komatsu remote monitoring and management technology provides insightful data about your equipment and fleet in user-friendly format.

Energy saving operation report

Komtrax delivers the energy-saving operation report based on the operating information such as fuel consumption, load summary and idling time, which helps you efficiently run a business.

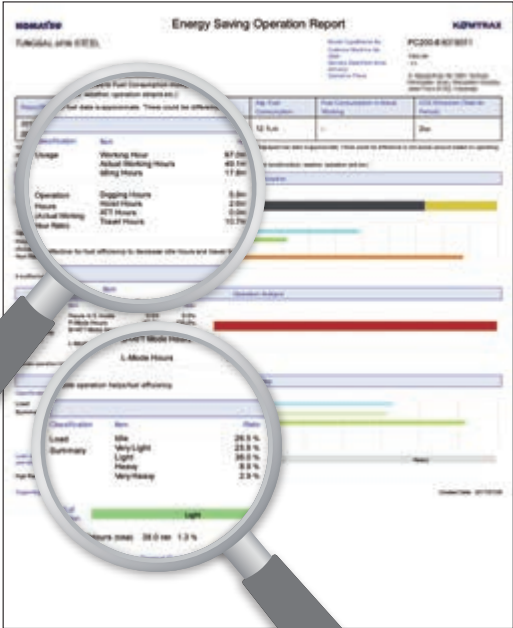

This report image is an example of hydraulic excavator

Equipment management support

Through the web application, a variety of search parameters are available to quickly find information about specific machines based on key factors. Moreover, Komtrax finds out machines with problems from your fleet and shows you through an optimal interface.

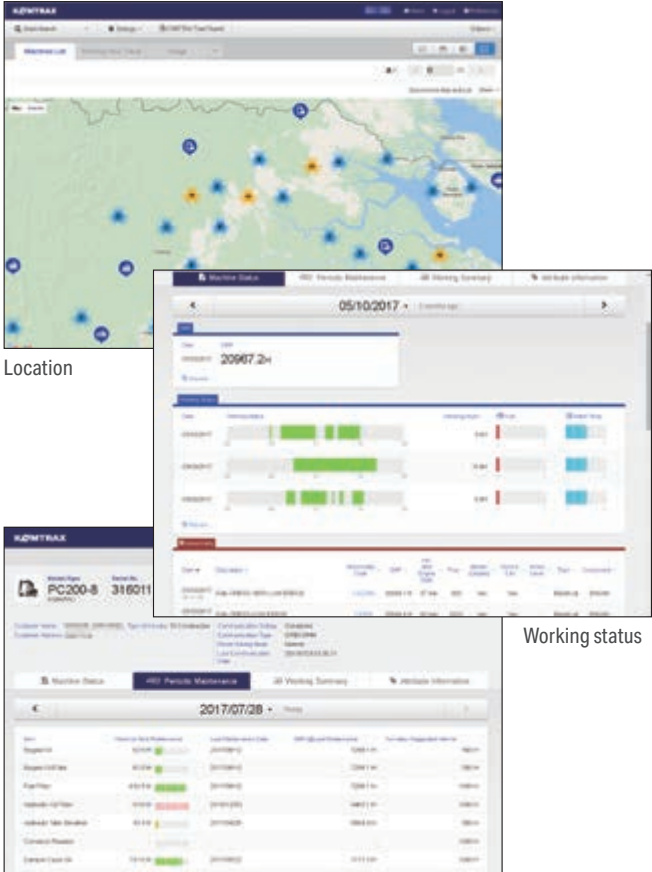

Location

Working status

Periodic maintenance

The report contents and data depend on the machine model.

Optimal strategy for efficient work

The detailed information that Komtrax puts at your fingertips helps you manage your fleet conveniently on the web anytime, anywhere. It gives you the power to make better daily and long-term strategic decisions.



Ecology & economy



Komatsu technology

Komatsu uniquely develops all major components including total control system, like engines, electronics, and hydraulic components. With this "Komatsu technology" and continuous customer feedback, Komatsu has been achieving great advancements of technology. This resulted in new generation of high performance and environmentally friendly products.

High performance and low emission SAA6D125E-5 Komatsu engine

This engine equipped with an electronically controlled high-pressure fuel injection system (common rail), air-cooled aftercooler, and high-efficiency turbocharger. This engine is U.S. EPA Tier 2 and EU Stage 2 emissions equivalent.

Net engine power: 213 kW / 286 HP

4 stage variable horsepower control

This machine is powered by the strong Komatsu SAA6D125E-5 engine. The engine features variable horsepower control that allows an extra burst of power delivery when the engine operates in medium to high speed ranges. On job-sites where the machine is allowed to operate within medium to high speeds, the machine can perform exceptionally well. In addition, since the machine can move speedily between job sites, work efficiency is improved.

unit: kW(HP)

	AUTO	MANU.		AUTO	MANU.
F1	171 (229)	171 (229)	F1		
F2			F2		
F3			F3		
F4	209 (280)	209 (280)	F4	209 (280)	209 (280)
F5			F5		
F6			F6		
F7	213 (286)	213 (286)	F7		
F8	212 (284)	212 (284)	F8	206 (276)	206 (276)

Circumference dynamic noise

The dynamic circumference noise is lowered significantly by 8 dB(A) compared with the conventional GD705A-4 by various kind of countermeasures like the hydraulic driven cooling fan, the variable displacement pump and etc.

Circumference dynamic noise level (ISO 6395) 108 dB(A)



Hydraulic driven cooling fan

Double seal cylinder (blade side shift cylinder)

A double-seal design is used for the blade side shift cylinder, which is installed near the ground, and thus susceptible to damage by dirt. Environmentally friendly by preventing oil leakage from the cylinder.

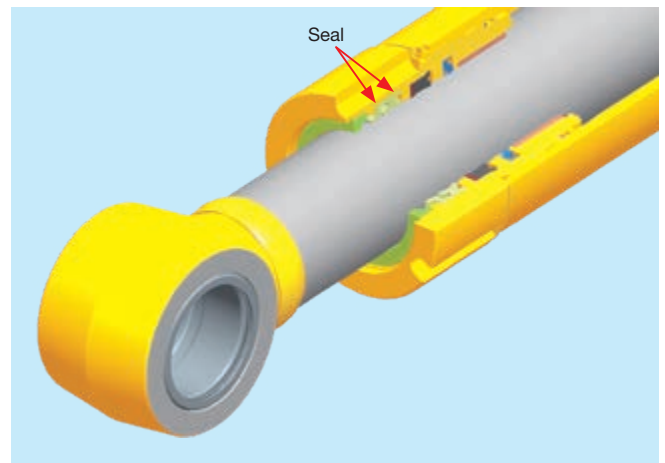

Work equipment



Komatsu genuine work equipment

Ripper

Digs up hard material cannot be removed by the moldboard. The ripper can accommodate up to 7 shanks.



Komatsu total support



Komatsu total support

To keep your machine available and minimize operation cost when you need it, the Komatsu distributor is ready to provide variety of support before and after procuring the machine.

Fleet recommendation

The Komatsu distributor can study customer job site and provide the most optimum fleet recommendation with detailed information to meet all of your application needs when you are considering to buy new machines or to replace the existing ones from Komatsu.



Product support

The Komatsu distributor secure the certain quality of machine will be delivered.

Parts availability

The Komatsu distributor is available for emergency inquiry by the customers for genuine, quality guaranteed Komatsu parts.

Technical support

Komatsu product support service (technical support) are designed to help customer. Komatsu distributor offers a variety of effective services how much Komatsu is dedicated to the maintenance and support of Komatsu machine.

- Preventive Maintenance (PM) clinic
- Oil & wear analysis program

Repair & maintenance service

The Komatsu distributor offers quality repair service, periodical maintenance, and maintenance service to the customer, utilizing and promoting Komatsu developed programs.

Komatsu Reman (Remanufactured) components

Komatsu Reman products are the result of the implementation of the Komatsu global Reman policy which establishes and agrees to reduce the owning, operating and total Life Cycle Costs (LCC) to Komatsu's customer through prompt delivery, high quality and competitively priced in own remanufactured products (QDC).



Specifications



Engine

Model	Komatsu SAA6D125E-5
Type	Water-cooled, 4-cycle, direct injection
Aspiration	Turbocharged and air to air aftercooled
Number of cylinders	6
Bore	125 mm
Stroke	150 mm
Piston displacement	11.04 l
Gross horsepower	
Gear 1	174 kW 233 HP / 2000 rpm
Gear 2-6	212 kW 284 HP / 1700 rpm
Gear 7	216 kW 290 HP / 2000 rpm
Gear 8	215 kW 288 HP / 1850 rpm
Net horsepower*	
Gear 1	171 kW 229 HP / 2000 rpm
Gear 2-6	209 kW 280 HP / 1700 rpm
Gear 7	213 kW 286 HP / 2000 rpm
Gear 8	212 kW 284 HP / 1850 rpm
Maximum torque	1298 Nm / 132 kgfm / 1400 rpm
Torque rise	28.0%
Fan speed	Max. 1650 rpm
Air cleaner	2-stage, dry-type
Electrical	24 V with 75 A alternator
Battery	2, low maintenance plus, 12 V, 930 cca

*: Net horsepower output for standard (SAE J1349) including air cleaner, alternator (Not charging), water lubricating oil, fuel pump, muffler and fan running at minimum speed. U.S. EPA Tier 2 and EU Stage 2 emissions equivalent.



Transmission and torque converter

Full power shift transmission with torque converter and lock-up.

Speeds (at rated engine speed)

Gear	Forward	Reverse
1st	5.1 km/h	5.7 km/h
2nd	7.9 km/h	8.9 km/h
3rd	9.5 km/h	10.7 km/h
4th	12.1 km/h	13.6 km/h
5th	14.9 km/h	Auto
6th	19.1 km/h	Auto
7th	29.2 km/h	Auto
8th	45.0 km/h	43.6 km/h

Maximum travel speed at engine high idle is 47.9 km/h.



Tandem drive

Oscillating welded box section	.658 mm × 258 mm
Side wall thickness: Inner	.22 mm
Outer	.19 mm
Wheel axle spacing	1653 mm
Tandem oscillation	15° forward, 15° reverse



Front axle

Type	Solid bar construction welded steel sections
Ground clearance at pivot	.625 mm
Wheel lean angle, right or left	16°
Oscillation, total	32°



Rear axle

Alloy steel, heat treated, full floating axle with lock/unlock differential.



Steering

Hydraulic power steering providing stopped engine steering meeting ISO 5010.	
Minimum turning radius	7.7 m
Maximum steering range, right or left	50°
Articulation	27°



Brakes

Service brake	Foot operated, sealed oil disc brakes, hydraulically actuated on four tandem wheels.
Parking brake	Manually actuated, spring applied, hydraulically released caliper.



Frame

Front frame structure	
Height	.350 mm
Width	.300 mm
Side	.14 mm
Upper, lower	.25 mm



Drawbar

A-shaped, u-section press formed and welded construction for maximum strength with a replaceable drawbar ball.	
Drawbar frame	235 mm × 25 mm



Circle

Single piece rolled ring forging. Six circle support shoes with replaceable wear surface. Circle teeth hardened on front 180° of circle.	
Diameter (outside)	1614 mm
Circle reversing control hydraulic rotation	360°



Moldboard

Hydraulic power shift fabricated from high carbon steel. Includes replaceable metal wear inserts, cutting edge and end bits.

Cutting edge and end bits are hardened.

Dimensions 4320 mm × 700 mm × 25 mm

Arc radius 414 mm

Cutting edge 203 mm × 16 mm

Replaceable/Reversible side edges 280 mm × 620 mm × 13 mm

Blade pull

Base GVW 12130 kgf

With ripper GVW 14210 kgf

Blade down pressure

Base GVW 11250 kgf

With ripper GVW 11480 kgf



Blade range

Circle center shift:

Right 590 mm

Left 545 mm

Moldboard side shift:

Right 965 mm

Left 966 mm

Maximum shoulder reach outside rear tires (frame straight)

Right 2360 mm

Left 2290 mm

Maximum lift above ground 450 mm

Maximum cutting depth 720 mm

Maximum blade angle, right or left 90°

Blade tip angle 45° forward, 7° backward



Hydraulics

Load-sensing closed center hydraulics with variable displacement piston pump. Short stroke/low effort direct acting control valves with preselected maximum flow setting to each function. Double acting anti-drift check valves on blade lift, tip, circle shift, articulation, and leaning wheels.

Output (at engine rated rpm) 193 l/min

Standby pressure 3.4 MPa / 35 kgf/cm²

Maximum system pressure 20.6 MPa / 250 kgf/cm²



Instruments

Electric monitoring system with diagnostics:

Gauges:

Standard Articulation, engine coolant temperature, fuel level, speed meter, T/M shift indicator, engine tachometer torque converter oil temperature

Warning lights/Indicator:

Standard Battery charge, brake oil pressure, inching temperature, directional indicator, engine oil pressure, hydraulic oil temperature, heater signal, lift arm lock, parking brake, differential lock, torque converter oil temperature, ECO, P mode, rpm set, high beam, working lights

Optional Blade accumulator



Capacities (refilling)

Fuel tank 400 l

Cooling system 38 l

Crank case 38 l

Transmission 50 l

Final drive 21 l

Tandem housing (each) 107 l

Hydraulic system 51 l

Circle reverse housing 10 l



Operating weight (approx.)

Includes lubricants, coolant, full fuel tank

Total 21650 kg

On rear wheels 15165 kg

On front wheels 6485 kg

With rear mounted ripper and front push plate:

Total 24380 kg

On rear wheels 17765 kg

On front wheels 6615 kg



Ripper (optional)

Ripping depth, maximum 390 mm

Ripper shank holders 7

Ripper shank holder spacing 415 mm

Penetration force 12360 kgf

Pry out force 28260 kgf

Machine length increase, beam raised 850 mm



Dimensions

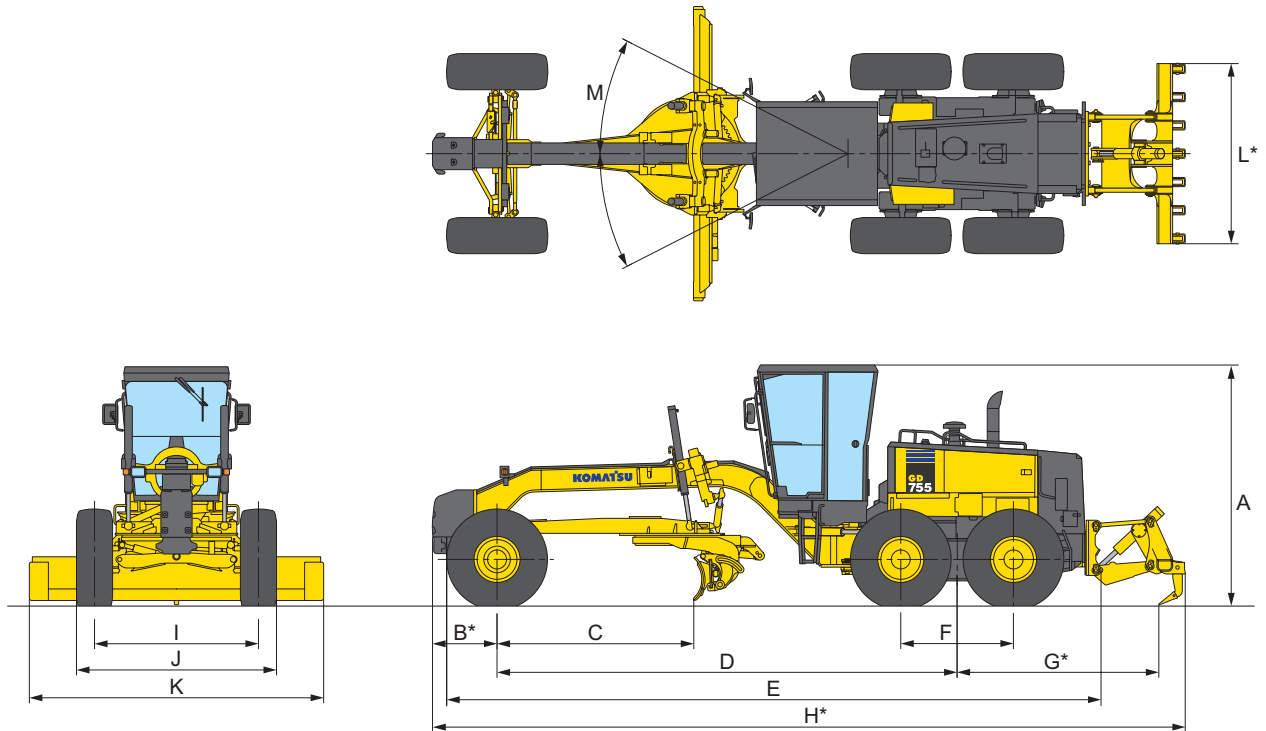

A	Height: low profile cab	3535 mm
B*	Center of front axle to counterweight (pusher)	945 mm
C	Cutting edge to center of front axle	2860 mm
D	Wheel base to center of tandem	6750 mm
E	Front tire to rear bumper (rear hook)	9450 mm
F	Tandem wheelbase	1653 mm
G*	Center of tandem to back of ripper	2955 mm
H*	Overall length	11045 mm
I	Track of gauge	2300 mm
J	Width of tires	2800 mm
K	Width of standard moldboard	4320 mm
L*	Ripper beam width	2645 mm
M	Articulation, left or right	27°

*optional



Wheels, front and rear

Tire	Rim size	Rim structure
20.5R25	17"	Multi-piece



Standard equipment

Engine and related items

- Air intake extension
- Double element air cleaner and dust indicator
- Engine: Komatsu SAA6D125E-5, turbocharged and air-to-air aftercooled, standard Variable Horse Power Control, 229-286 net horsepower
- Fuel line pre-filter
- Hood-sides for engine compartment

Electrical systems

- Alarm, back-up
- Alternator, 24 V/75 A
- Battery, extreme duty, 930 cca each
- Dome light, cab
- Horn, electric
- Indicators: parking brake, differential
- High beam, rpm set, engine oil pressure, battery charge, brake oil pressure, transmission system electric circuit
- Monitor, differential oil temperature
- Lights: back-up, stop, tail, directional, headlights
- Speedometer

Operator environment

- A/C (R134a) with heater
- Cab: low profile enclosed ROPS/FOPS (ISO 3471 / ISO 3449) with safety tinted glass windows with wiper and washer, electric defroster rear window
- Console, adjustable with instrument panel monitoring system
- Mirrors: interior cab, right and left exterior mirrors
- Seat, deluxe adjustable cloth with retractable seat belt
- Sound suppression, cab and floor mat
- Wipers, front, upper

Power train

- Axle, rear full floating, planetary type
- Brake, parking, spring applied, hydraulic release, disc type
- Differential, lock/unlock
- Dual mode transmission (8F-8R) power shift, direct drive and torque converter with auto shift
- Service brakes, fully hydraulic wet disc

Work equipment and hydraulics

- Circle, drawbar mounted, 360° rotation hydraulic blade lift and circle side shift
- Circle slip clutch
- Hydraulic system, closed center, load sensing
- Moldboard: 4320 mm × 700 mm × 25 mm with replaceable side edge, through hardened cutting edges
- 280 mm × 620 mm × 13 mm, hydraulic blade side shift and hydraulic tilt with anti-drift check valves. Maximum moldboard angle position 90° right & left
- Overlay end bits
- Steering, full hydraulic with tilt steering wheel plus leaning front wheels and frame articulation w/anti-drift check valves
- 8 section hydraulic control valve

Other standard equipment

- Fuel tank, ground level access
- Painting, Komatsu standard color scheme
- Steps and handrails, rear, right, and left side
- Tool box with lock
- Vandalism protection includes lockable access to fuel tank, hydraulic tank, and engine side covers



Optional equipment

- Accumulators, anti-shock for blade lift
- AM/FM radio
- Battery disconnect switch
- Fire extinguisher
- General toolkit
- Komtrax wireless monitoring system

- Pre-cleaner, Turbo II
- Pusher plate, additional
- Ripper, assembly, rear mounted
- Ripper shanks and points, 4 additional
- Warning light, amber colored rotating beacon, cab roof mounted

- Water separator
- Wipers, front lower, and rear
- Work lamps: front (2), rear (2)
- 9 section hydraulic control valve

Standard equipment may vary for each country, and this specification sheet may contain attachments and optional equipment that are not available in your area. Up to 20% blended biodiesel fuel and paraffine fuel can be used. Please consult your Komatsu distributor for detailed information.

Your Komatsu partner:

KOMATSU

[komatsu.com](https://www.komatsu.com)