

KOMATSU

PC350-8M0 PC350LC-8M0



Photos may show equipments not available in your area

Hydraulic excavator

Engine power

194 kW / 260 HP @ 1950 rpm

Operating weight

PC350-8M0: 32600 - 32960 kg
PC350LC-8M0: 33660 - 34040 kg

Bucket capacity

0.52 - 2.30 m³

Walk-around



Heavy-duty boom

Heavy-duty arm

Quarry bucket

Engine power

194 kW / 260 HP @ 1950 rpm

Operating weight

PC350-8M0: 32600 - 32960 kg

PC350LC-8M0: 33660 - 34040 kg

Bucket capacity

0.52 - 2.30 m³

Gives you higher returns and peace of mind

Productivity, ecology & economy

- High production and low fuel consumption by total control of the engine, hydraulic and electronic system
- Low emission engine & low operation noise
- Large drawbar pull and digging force
- Two-mode setting for boom

Comfort & safety

- Large comfortable cab
- ROPS cab (ISO 12117-2)
- Rear view monitor system (optional)

ICT* & Komtrax

- Large multi-lingual high resolution Liquid Crystal Display (LCD) monitor
- Equipment Management Monitoring System
- Komtrax

Maintenance & reliability

- Easy maintenance
- High rigidity work equipment



* Information and Communication Technology

Productivity, ecology & economy

Low fuel consumption

The newly-developed Komatsu SAA6D114E-3 engine enables NOx emissions to be significantly reduced with the accurate multi-staged fuel injection by the engine controller. It improves total engine durability using the high-pressure fuel injection system developed specifically for construction machinery. This excavator significantly reduces hourly fuel consumption using the highly-efficient matching techniques of the engine and hydraulic unit and also provides features that promote energy-saving operations such as the E mode and ECO gauge.

Fuel consumption

3% reduced

Vs. PC350-8
Based on typical work pattern collected via Komtrax.
Fuel consumption varies depending on job conditions.

Komatsu technology

Komatsu develops and produces all major components, such as engines, electronics and hydraulic components, in house. With this "Komatsu technology" and adding customer feedback, Komatsu is achieving great advancements in technology. To achieve both high levels of productivity and economical performance, Komatsu has developed the main components with a total control system. The result is a new generation of high performance and environment-friendly excavators.

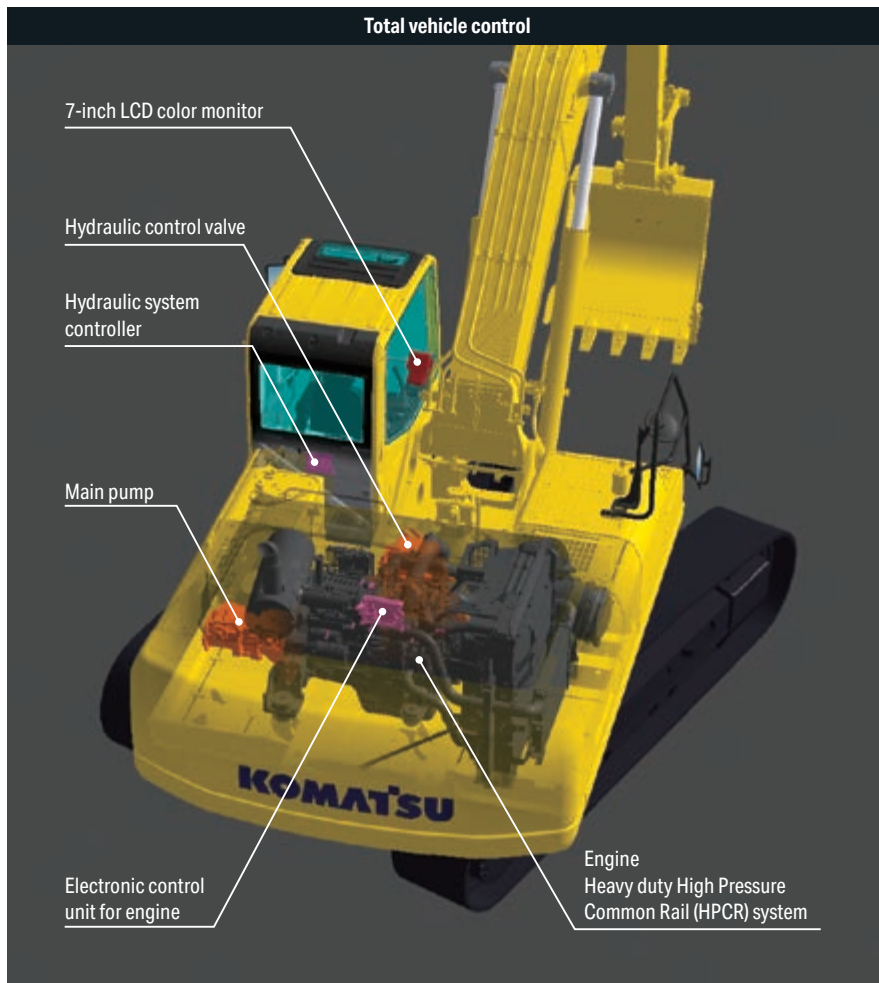

Low emission engine

Komatsu SAA6D114E-3 reduced NOx emission by 33% compared with the PC350-7. This engine is U.S. EPA Tier 3 and EU Stage 3A emissions equivalent.



Low operation noise

Enables a low noise operation using the low-noise engine and methods to cut noise at source.

Idling caution

To prevent unnecessary fuel consumption, an idling caution is displayed on the monitor, if the engine idles for 5 minutes or more.



ECO gauge that assists energy-saving operations

Equipped with the ECO gauge that can be recognized at a glance on the right of the multi-function color monitor for environment-friendly energy-saving operations. Allows focus on operation in the green range with reduced CO₂ emissions and efficient fuel consumption.



ECO gauge

Working modes selectable

The PC350-8M0 excavator is equipped with six working modes (P, E, L, B, ATT/P and ATT/E mode). Each mode is designed to match engine speed and pump output to the application. This provides the flexibility to match equipment performance to the job at hand.



Working mode	Application	Advantage
P	Power mode	<ul style="list-style-type: none"> Maximum production/power Fast cycle times
E	Economy mode	<ul style="list-style-type: none"> Good cycle times Better fuel economy
L	Lifting mode	<ul style="list-style-type: none"> Suitable attachment speed Lifting capacity is increased 7% by raising hydraulic pressure.
B	Breaker mode	<ul style="list-style-type: none"> Optimum engine rpm, hydraulic flow
ATT/P	Attachment Power mode	<ul style="list-style-type: none"> Optimum engine rpm, hydraulic flow, 2 way Power mode
ATT/E	Attachment Economy mode	<ul style="list-style-type: none"> Optimum engine rpm, hydraulic flow, 2 way Economy mode

Larger maximum drawbar pull

Larger maximum drawbar pull provides superb steering and slope climbing performance.

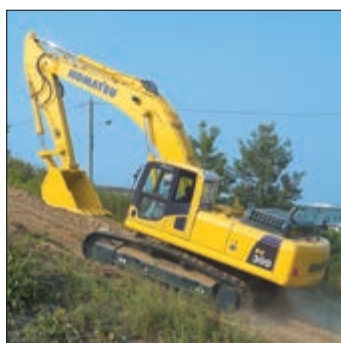

Maximum drawbar pull:
264 kN (26900 kgf)

Large digging force

When press the left knob switch which is called the one-touch Power max. switch and when it is kept pressed, this function temporarily increases digging force for 8.5 seconds of operation.

Maximum arm crowd force (ISO 6015):

160 kN (16.3 t) ➔ **171 kN (17.4 t)** **7% UP**
(with Power max.)

Maximum bucket digging force (ISO 6015):

213 kN (21.7 t) ➔ **228 kN (23.2 t)** **7% UP**
(with Power max.)

Measured with Power max. function, 3185 mm arm and ISO 6015 rating.



One-touch Power max. switch

Smooth loading operation

Two return hoses improve hydraulic performance. In the arm out function, a portion of the oil is returned directly to the tank providing smooth operation.

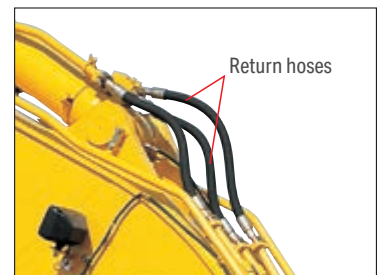

Return hoses

Two-mode setting for boom

Smooth mode provides easy operation for gathering blasted rock or scraping down operation. When maximum digging force is needed, switch to Power mode for more effective excavating.

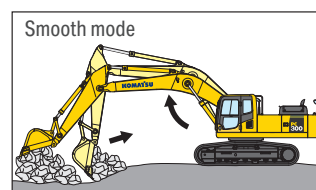

Smooth mode
Boom floats upward, reducing lifting of machine front. This facilitates gathering blasted rock and scraping down operations.

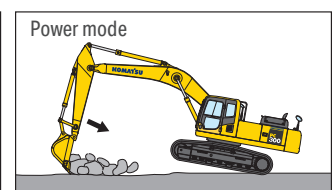

Power mode
Boom pushing force is increased, ditch digging and box digging operation on hard ground are improved.

Comfort



Low cab noise

The newly-designed cab is highly rigid and has excellent sound absorption ability. Thorough improvement of noise source reduction and use of low noise engine, hydraulic equipment, and air conditioner allows this machine to generate a low level of noise.

Low vibration with cab damper mounting

PC350-8M0 uses viscous damper mounting for cab that incorporates longer stroke and the addition of a spring. The new cab damper mounting combined with high rigidity deck aids vibration reduction at operator seat.

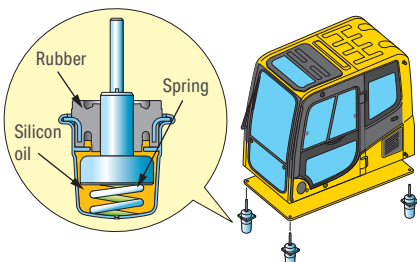

Wide newly-designed cab

Newly-designed wide spacious cab includes seat with reclining backrest. The seat height and longitudinal inclination are easily adjusted using a pull-up lever. You can set the appropriate operational posture of armrest together with the console. Reclining the seat further enables you to place it into the fully flat state with the headrest attached.



Pressurized cab

Optional air conditioner (A/C), air filter and a higher internal air pressure (+6.0 mm Aq) prevent external dust from entering the cab.

Automatic air conditioner (A/C)

Enables you to easily and precisely set cab atmosphere with the



instruments on the large LCD. The bi-level control function keeps the operator's head and feet cool and warm respectively. This improved air flow function keeps the inside of the cab comfortable throughout the year. Defroster function keeps front glass clear.

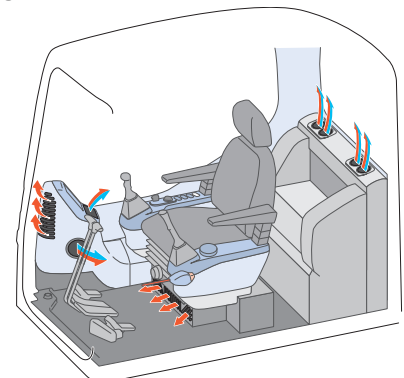

Safety

ROPS cab

The machine is equipped with a ROPS cab that conforms to ISO 12117-2 for excavators as standard equipment. The ROPS cab has high shock-absorption performance, featuring excellent durability and impact strength. It also satisfies the requirements of OPG top guard level 1 (ISO 10262) for falling objects. Combined with the retractable seat belt, the ROPS cab protects the operator in case of tipping over and against falling objects.



Slip-resistant plates

Highly durable slip-resistant plates maintain superior traction performance for the long term.



Pump/engine room partition

Pump/engine room partition prevents oil from spraying onto the engine if a hydraulic hose should burst.

Lock lever

Locks the hydraulic pressure to prevent unintentional movement. Neutral start function allows machine to be started only in lock position.



Large side-view, rear and sidewise mirrors

Enlarged left-side mirror and addition of rear and side mirror allow the PC350-8M0 to meet the visibility requirements (ISO 5006).

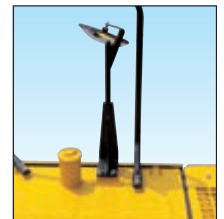

Rear view monitor system (optional)

The operator can view the rear of the machine with a color monitor screen.



Rear view image on monitor

Thermal and fan guards

Thermal and fan guards are placed around high-temperature parts of the engine and fan drive.



ICT & Komtrax



Large multi-lingual high resolution LCD monitor

A large user-friendly high resolution LCD color monitor enables safe, accurate and smooth work. Visibility and resolution are further improved compared with current 7-inch large LCD. Simple and easy to operate switches. Function keys facilitate multi-function operations. Displays data in 13 languages to globally support operators around the world.

Indicators

- 1 Auto-decelator
- 2 Working mode
- 3 Travel speed
- 4 Engine water
- 5 Hydraulic oil temperature gauge
- 6 Fuel gauge
- 7 ECO gauge
- 8 Fuel consumption gauge
- 9 Function switches menu

Basic operation switches

- 1 Auto-decelator
- 2 Working mode selector
- 3 Traveling selector
- 4 Buzzer cancel
- 5 Wiper
- 6 Windshield washer

Supports efficiency improvement

The main screen displays advices for promoting energy-saving operations as needed. The operator can use the ECO guidance menu to check the operation records, ECO guidance records, average fuel consumption logs, etc.



ECO guidance



ECO guidance menu

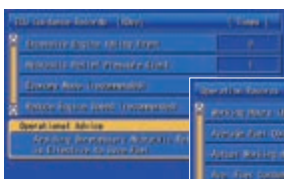

ECO guidance records

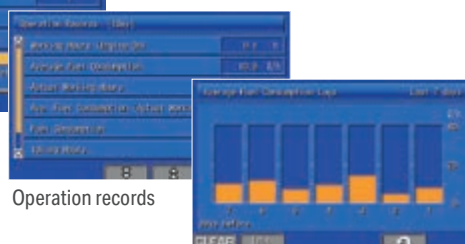

Operation records

Average fuel consumption logs

Equipment management monitoring system

Monitor function

Controller monitors engine oil level, coolant temperature, battery charge air clogging, etc. If the controller finds any abnormality, it is displayed on the LCD.



Maintenance function

The monitor informs replacement time of oil and filters on the LCD when the replacement interval is reached.



Trouble data memory function

Monitor stores abnormalities for effective troubleshooting.



The Komatsu remote monitoring and management technology provides insightful data about your equipment and fleet in user-friendly format.

Energy saving operation report

Komtrax delivers the energy-saving operation report based on the operating information such as fuel consumption, load summary and idling time, which helps you efficiently run a business.

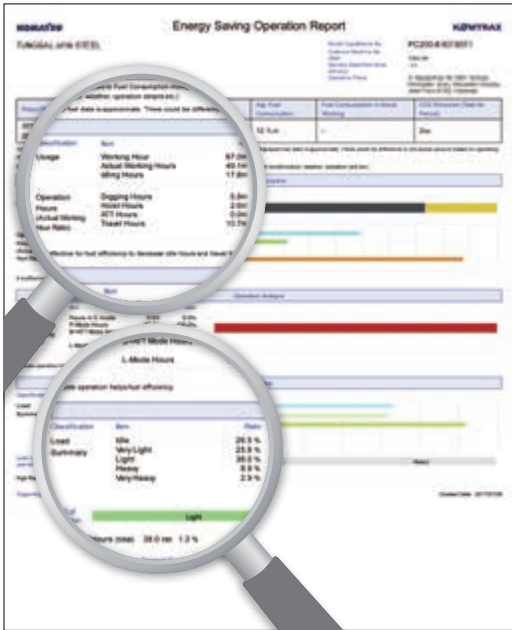

This report image is an example of hydraulic excavator

Equipment management support

Through the web application, a variety of search parameters are available to quickly find information about specific machines based on key factors. Moreover, Komtrax finds out machines with problems from your fleet and shows you through an optimal interface.

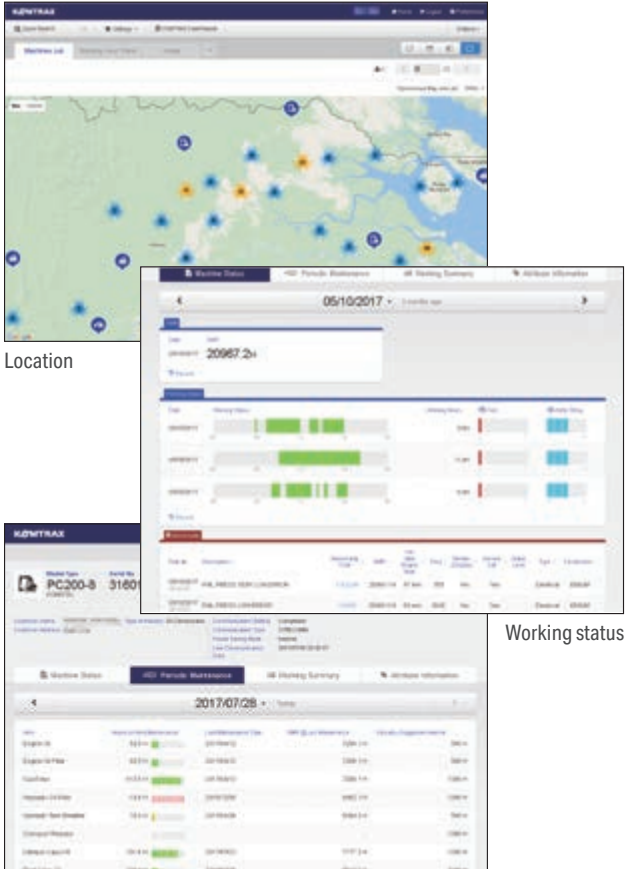

Location

Working status

Periodic maintenance

The report contents and data depend on the machine model.

Optimal strategy for efficient work

The detailed information that Komtrax puts at your fingertips helps you manage your fleet conveniently on the web anytime, anywhere. It gives you the power to make better daily and long-term strategic decisions.



Maintenance

Side-by-side cooling

Since radiator and oil cooler are arranged in parallel, it is easy to clean, remove and install them.



Equipped with the drain valve as standard

Prevents clothes and the ground from becoming contaminated due to oil leakage when replacing the engine oil.



High-capacity air cleaner

High capacity air cleaner is comparable to that of larger machines. The larger air cleaner can extend air cleaner life during long-term operation and prevents early clogging and resulting power decrease. Reliability is improved by a new seal design.



Easy access to engine oil filter and fuel drain valve

Engine oil level gauge, and fuel filter are one side mounted to improve accessibility. Engine oil filter and fuel drain valve are remotely mounted to improve accessibility.



Engine oil filter



Fuel drain valve

Long work equipment greasing interval (optional)

High quality bushings and resin shims are optionally available for work equipment pins excluding bucket, extending greasing interval to 500 hours.

Equipped with the fuel pre-filter (with water separator)

Removes water and contaminants in the fuel to prevent fuel problems.



Long-life oil, filter

Uses high-performance filtering materials and long-life oil. Extends the oil and filter replacement interval.

Engine oil & Engine oil filter	every 500 hours
Hydraulic oil	every 5000 hours
Hydraulic oil filter	every 1000 hours



Large fuel tank capacity

Large fuel tank capacity extends operating hours before refueling. Fuel tank is treated for rust prevention.

Reliability

High rigidity work equipment

Boom and arms are constructed of thick plates of high tensile strength steel. In addition, these structures are designed with large cross-sectional areas and generous use of castings. The result is working attachments that exhibit long term durability and high resistance to bending and torsional stress.

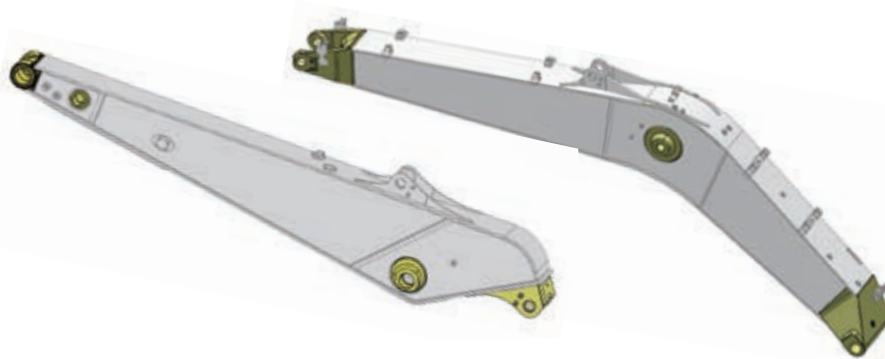

Sturdy frame structure

The revolving frame, center frame and undercarriage are designed by using the most advanced three-dimensional CAD and Finite Element Method (FEM) analysis technology.

Highly reliable electronic devices

Exclusively designed electronic devices have passed severe testing.

- Controller
- Sensors
- Connectors
- Heat resistant wiring

Grease sealed track

PC350-8M0 uses grease sealed tracks for extended under-carriage life.

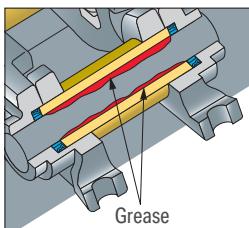

Track link with strut

PC350-8M0 uses track links with strut, providing superb durability.

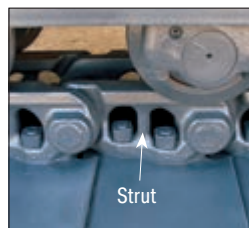

Reliable components

All of the major machine components, such as engine, hydraulic pumps, hydraulic motors and control valves are exclusively designed and manufactured by Komatsu.

Options

- Cab front full height guard level 1 (ISO 10262)



- Cab front full height guard level 2 (ISO 10262)



- Additional front lights
- Rain visor



- Air pre-cleaner



- OPG top guard level 2 (ISO 10262)



- Strengthened track frame undercover



- Sun visor



- Seat, suspension



Komatsu brand bucket

Komatsu brand bucket for general purpose with wide bucket width

Me bucket

- Low resistant excavation
- High productivity
- High durability
- High fuel efficiency

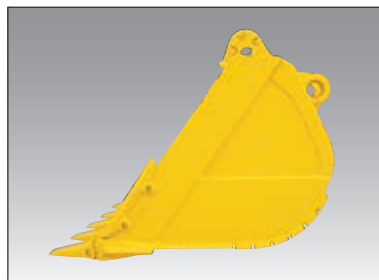

Conventional



Me bucket

Category and feature

Category	Load / Wear / Soil (application)	Image
Light Duty LD	<p>Load Machine power remains low during the majority of the work. No impact load.</p> <p>Wear Material is not abrasive.</p> <p>Soil Dirt, loam and clay.</p>	
General Purpose GP	<p>Load Machine power is mostly medium, but occasionally high. Bucket movements are smooth with minor shock load. Bucket penetrates easily.</p> <p>Wear Material is lightly abrasive. Some sand may be medium abrasive.</p> <p>Soil Mostly loose sand, gravel and finely broken materials.</p>	
Heavy Duty HD	<p>Load Machine power is high during majority of the work. Medium, but continuous shock load.</p> <p>Wear Material is abrasive. Light scratch marks can be seen at the bucket.</p> <p>Soil Limestone, shot rock, compact mix of sand, gravel and clay.</p>	
Extra Heavy Duty XHD	<p>Load Machine power is high during most of the work, often at maximum. Dynamic shock loads are frequent and machine may shake.</p> <p>Wear Material is very abrasive. Large scratch marks are visible and, or deform metal. Works within heaps of rock with occasional un-shot rock and rock boulders.</p> <p>Soil Granite, basalt, quartz sand, compact and sticky clay.</p>	

Bucket line-up

Category	Bucket type	Capacity (m³)	Width*1 (mm)	Weight*2 (kg)	Tooth quantity	Boom + arm (m)			Tooth type			
						6.47+3.19	6.00+2.22 SE Spec.	6.00+2.55 SE Spec.	Vertical	Horizontal	PAB*3	KMAX
LD	Conventional	1.80	<> <1700>	940	5	●	—	—	✓	✓	✓	✓
GP	Conventional	0.52	740<610>	664	3	○	—	—	✓			
		1.14	1275<1145>	900	5	○	—	—	✓	✓	✓	
		1.40	1445<1340>	1015	5	○	—	—	✓	✓	✓	
		1.60	1645<1515>	1102	5	○	—	—	✓	✓	✓	✓
HD	Conventional	1.40	1445<1340>	1508	5	○	—	—		✓	✓	✓
		1.40	1445<1340>	1430	5	○	—	—		✓	✓	✓
		1.60	1645<1515>	1610	5	○	—	—		✓	✓	✓
	Me bucket	1.90	1445<1340>	1830	5	×	—	○		✓	✓	✓
		2.10	1620<1560>	2090	5	×	○	□				✓
		2.30	1750<1690>	2200	5	×	□	●				✓
XHD	Me bucket	1.40	1445<1340>	1585	5	○	—	—		✓	✓	
		1.60	1645<1515>	2165	5	○	—	—		✓	✓	

*1 With side cutters or side shrouds, <> without side cutters or side shrouds *2 With side cutters *3 PAB: Pin And Bushing system

○: General purpose use, density up to 1.8 t/m³ □: General purpose use, density up to 1.5 t/m³ ●: Light duty work, density up to 1.2 t/m³ ×: Not usable ✓: Selectable

Feature of [Me bucket] (More suitable shape and effectiveness bucket)

High productivity by low-resistant excavation

The new ideal bucket profile produces lower resistance at inside & outside bucket and production will be greatly increased.

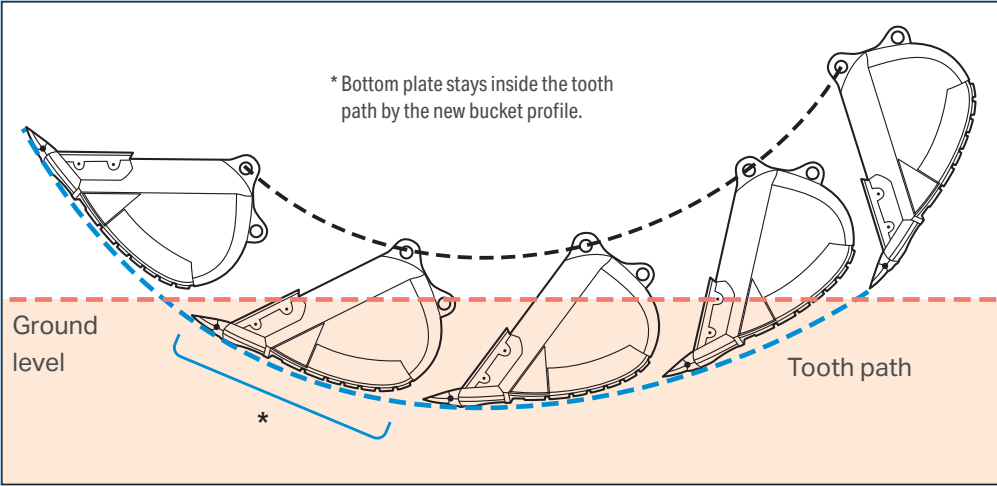

Feature of [PAB tooth] (Pin And Bushing system tooth)

- Able to fit on the bucket with horizontal pin type adapter
- Easy change-out only with a ratchet wrench
- Longer tooth life by easy rotation and turnover
- Durable and reusable PAB pin with flat surface

Limited to where horizontal pin type tooth is mainly used.

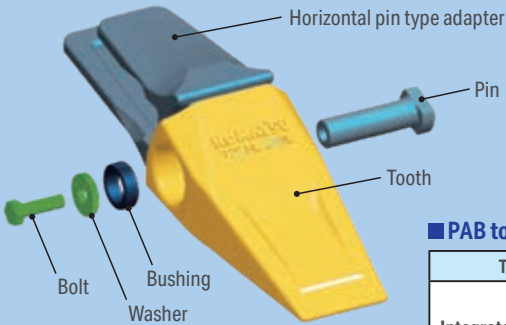

PAB tooth line-up

Type	Style
Integrated Long Life IL	
Heavy Standard HS	
Heavy Rock HR	



Set PAB tooth to horizontal pin type adapter



Insert exclusive pin to the adapter pin hole



Set bushing, washer and bolt and tighten by a ratchet wrench

Special purpose bucket & ripper

■ Feature and specifications

Type	Feature	Bucket capacity (ISO 7451 heaped)	Width	Image
Ripper bucket	Suitable for digging rock bed or hard clayey soil when normal buckets cannot penetrate deep enough. Loading is also possible.	0.90 m ³	1200 mm	



Hensley brand bucket

Diverse bucket capacity by application featuring "KMAX" tooth system



- Wide range selection for each application
- Larger profile and capacity to maximize production
- Multiple width options to meet specific job requirements and reduce backfill

Category and recommended applications

Category	Recommended applications	Image
Trenching and loading TL	Dirt, loam, sand, gravel, loose clay, abrasive soils with limited rock mixture.	
Heavy Duty plate lip bucket with wear plate HP	Abrasive soils, compact or dense clay, loose rock and gravel.	
Heavy Duty plate lip bucket with wear plate & wear strips HPS	Abrasive soils, compact or dense clay, loose rock and gravel.	
Extreme Duty plate lip bucket with special features HPX	Shot rock, stratified materials, quarry or tough, highly abrasive applications.	

Bucket line-up

Category	Capacity (m³)	Width (mm)	Weight (kg)	Tooth quantity	Boom + arm (m)			Tooth type
					6.47+3.19	6.00+2.22 SESpec.	6.00+2.55 SESpec.	
TL	0.68	610	962	3	☆	☆	☆	✓
	0.93	762	1108	4	☆	☆	☆	✓
	1.18	914	1209	4	☆	☆	☆	✓
	1.44	1067	1336	5	○	☆	☆	✓
	1.70	1219	1437	5	●	☆	☆	✓
	1.96	1372	1582	6	●	☆	○	✓
HP	0.68	610	1051	3	☆	☆	☆	✓
	0.93	762	1173	4	☆	☆	☆	✓
	1.18	914	1315	4	☆	☆	☆	✓
	1.44	1067	1451	5	□	☆	☆	✓
	1.70	1219	1573	5	●	☆	☆	✓
	1.96	1372	1716	6	■	☆	○	✓
HPS	0.68	610	1121	3	☆	☆	☆	✓
	0.93	762	1281	4	☆	☆	☆	✓
	1.18	914	1398	4	☆	☆	☆	✓
	1.44	1067	1561	5	□	☆	☆	✓
	1.70	1219	1696	5	●	☆	☆	✓
	1.96	1372	1857	6	■	○	○	✓
HPX	0.68	610	1184	3	☆	☆	☆	✓
	0.93	762	1359	4	☆	☆	☆	✓
	1.18	914	1501	4	○	☆	☆	✓
	1.44	1067	1696	5	□	☆	☆	✓
	1.70	1219	1838	5	●	○	○	✓
	1.96	1372	1980	6	■	○	□	✓
2.22	1524	2119	6	×	□	□	✓	

☆: Heavy duty work, density up to 2.1 t/m³ ○: General purpose use, density up to 1.8 t/m³
 □: General purpose use, density up to 1.5 t/m³ ●: Light duty work, density up to 1.2 t/m³
 ■: Light duty work, density up to 0.9 t/m³ ×: Not usable ✓: Selectable

Feature of KMAX tooth system

- Better penetration and cycle times
- Hardness throughout the tooth
- Unique high strength design
- Unique reusable fastener
- Less "throw away" waste
- Fast tooth changeover



Tooth



477-532 Brinell level of hardness throughout the tooth.

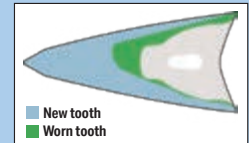

The KMAX RC style tooth shown here offers a consumption ratio of 60%.

Fastener

Simple, reusable fastener system saves time and money by unlocking with a simple 90-degree turn.



To lock, use the correct size socket, rotate the pin locking shaft 90-degree clockwise to finish the installation.



When removing the fastener, use the correct size socket to rotate the pin-locking shaft 90-degree counter-clockwise.

KMAX tooth line-up

Feature	Style
F Flare: Loose material for clean bottom and greater fill	
SYL Standard: General applications	
SD Chisel: General purpose tooth designed for penetration	
RC Rock Chisel: Designed for penetration and long wear life	
T Tiger: Designed for good penetration with ribs for strength	
TV Tiger: Offers best penetration in tight material	
UT Twin Tiger: Offers longer life penetration for corners	
WT Twin Tiger: Designed for penetration for corners	

Some application may not have been available in your country or region. If you are interested in such application, please contact a Komatsu office near you.

Quarry hydraulic excavator

The PC350-8M0 is a specially designed heavy-duty machine. The PC350-8M0 has strengthened work equipment and various machine body parts for use in severe job sites such as quarry and gravel gathering, etc.

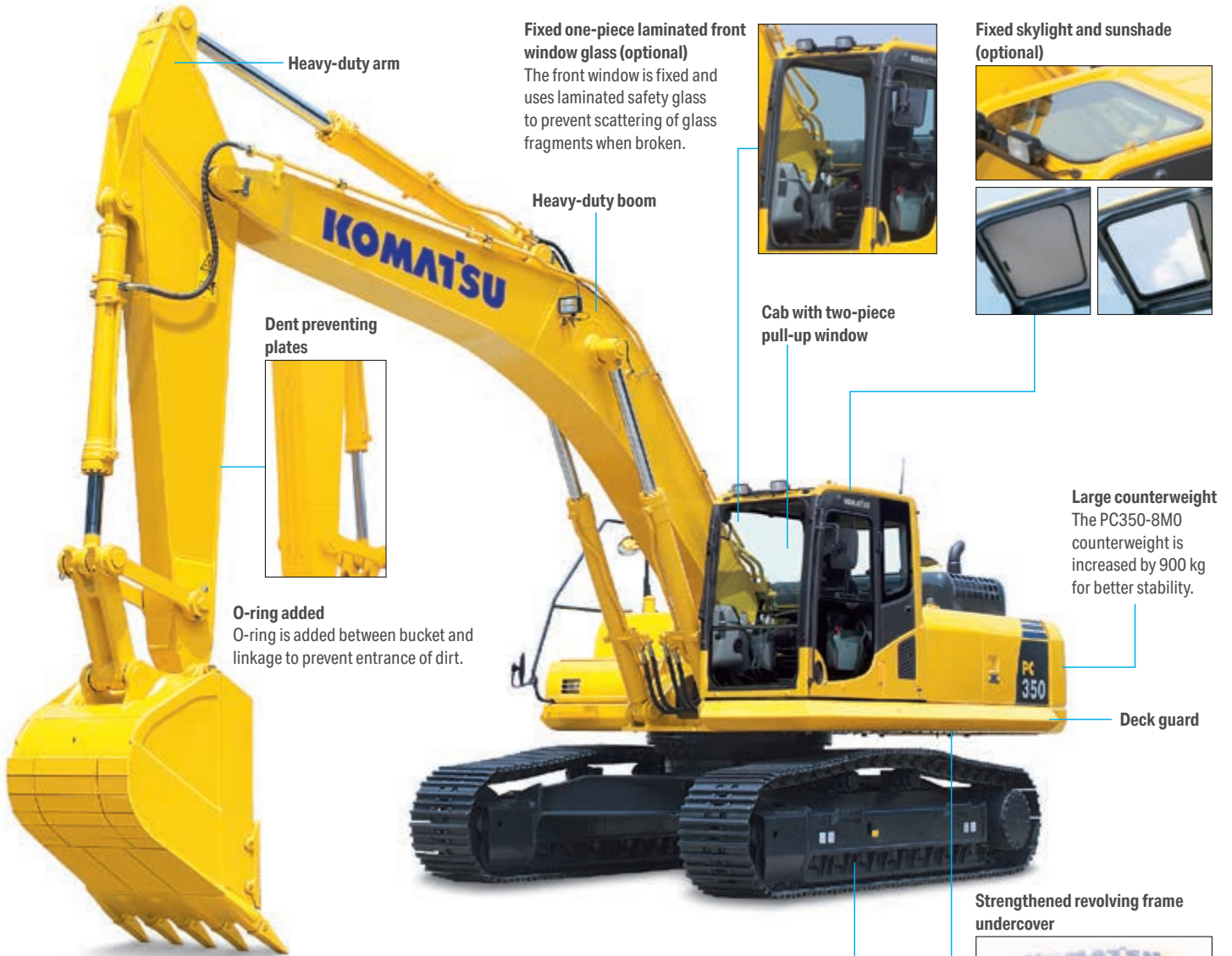

Heavy-duty arm

Fixed one-piece laminated front window glass (optional)
The front window is fixed and uses laminated safety glass to prevent scattering of glass fragments when broken.

Fixed skylight and sunshade (optional)

Heavy-duty boom



Dent preventing plates



Cab with two-piece pull-up window

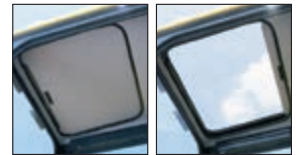

O-ring added
O-ring is added between bucket and linkage to prevent entrance of dirt.

Large counterweight
The PC350-8M0 counterweight is increased by 900 kg for better stability.

Deck guard

Quarry bucket and work equipment

PC350-8M0 bucket is designed exclusively for quarry use and is higher strength for impact and wear. Various parts of work equipment are also strengthened.

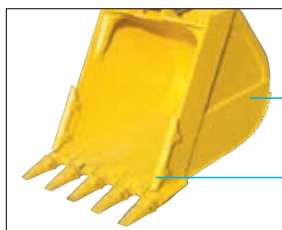

Side reinforcement plates
16 mm thickness high-tensile strength steel used.
Side shrouds

Full roller guard

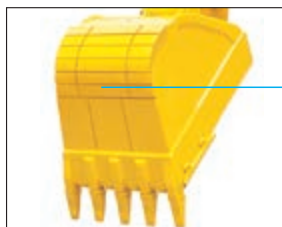

Bottom wear plate
19 mm thickness high-tensile strength steel used.

Corner tooth adapters

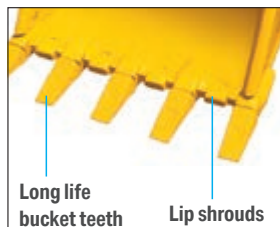

Long life bucket teeth **Lip shrouds**

Strengthened revolving frame undercover

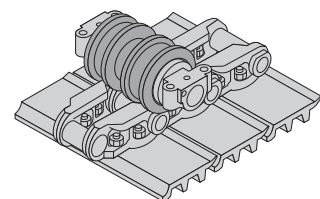

Double-flange track roller

Double-flange roller guides track link correctly and extends life of undercarriage.

Number of double-flange track rollers

PC350-8M0	3 each side
PC350LC-8M0	4 each side

SE spec.

PC350/350LC-8M0 SE spec. is equipped with a large reinforced Me bucket for quarrying work. It increases the efficiency of loading a dump truck with large amounts of loose materials such as blasted rock.



Attachments

Komatsu genuine attachment tool

Komatsu-recommended attachment tools for hydraulic excavators

A wide range of attachment tools are provided to suit customers' specific applications.

Hydraulic breaker

The hydraulic breaker is an attachment tool used for crushing rock beds and paved surfaces, demolishing concrete structures, etc. The large gas chamber, ideal gas pressure ratio, and long-stroke piston deliver a powerful impact force. Since the breaker unit does not require an accumulator, the number of parts has been reduced, resulting in lower maintenance costs.



Crusher

This attachment tool is used for demolishing concrete structures. Since it does not have a striking mechanism and features low noise and low vibration, it is suitable for work in urban areas. The open-close cylinder is equipped with a speed-up valve for increasing work speed.



Primary crusher



Pulverizer



Scrap & demolition shear

The scrap & demolition shears have multiple applications for both overhead-demolishing the steel structure (general structural steels) and cutting structural steel with required length at ground level (in foundries, dumps, scrap yards).



Applications of attachment tools

Application/ Attachment tool	Civil engineering	Quarry	Demolition	Industrial waste disposal	Iron-making	Utility construction	Rental
Hydraulic breaker	○	○	○	○	○	○	○
Crusher (primary crusher)			○				○
Crusher (pulverizer)			○	○			○
Scrap & demolition shear			○	○			○

Komatsu total support



Komatsu total support

To keep your machine available and minimize operation cost when you need it, Komatsu distributor is ready to provide a variety of supports before and after procuring the machine.

Fleet recommendation

Komatsu distributor can study the customer's job site and provide the most optimum fleet recommendation with detailed information to meet all of your application needs when you are considering to buy new machines or replace the existing ones from Komatsu.



Product support

Komatsu distributor gives the proactive support and secures the quality of the machinery that will be delivered.

Parts availability

Komatsu distributor is available for emergency inquiry by the customers for genuine, quality guaranteed Komatsu parts.

Technical support

Komatsu product support service (technical support) is designed to help customer. Komatsu distributor offers a variety of effective services to show how much Komatsu is dedicated to the maintenance and support of Komatsu machine.

- Preventive Maintenance (PM) clinic
- Oil & wear analysis program
- Undercarriage inspection service, etc.

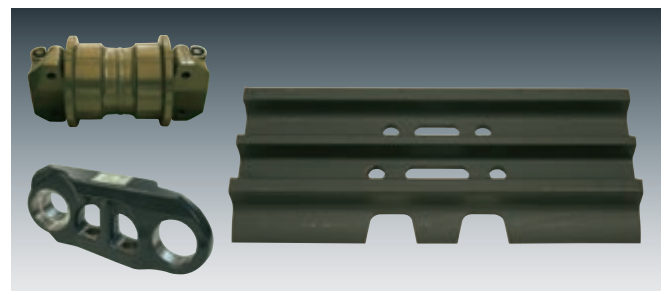

Repair & maintenance service

Komatsu distributor offers quality repair and maintenance service to the customer, utilizing and promoting Komatsu developed programs.

Komatsu Reman (remanufactured) components

Komatsu Reman products are the result of the implementation of the Komatsu global policy which establishes and agrees to reduce the owning, operating and total Life Cycle Costs (LCC) to Komatsu's customer through high quality, prompt delivery and competitively priced in own remanufactured products (QDC).



Specifications



Engine

Model Komatsu SAA6D114E-3
 Type Water-cooled, 4-cycle, direct injection
 Aspiration Turbocharged, aftercooled
 Number of cylinders 6
 Bore 114 mm
 Stroke 135 mm
 Piston displacement 8.27 l
 Horsepower:
 SAE J1995 Gross 194 kW / 260 HP
 ISO 9249 / SAE J1349 Net 187 kW / 250 HP
 Rated rpm 1950 rpm
 Fan drive method for radiator cooling Mechanical
 Governor All-speed control, electronic

U.S. EPA Tier 3 and EU Stage 3A emissions equivalent.



Hydraulics

Type HydraMind (Hydraulic Mechanical Intelligence New Design) system, closed-center system with load sensing valves and pressure compensated valves
 Number of selectable working modes 6
 Main pump:
 Type Variable displacement piston type
 Pumps for Boom, arm, bucket, swing, and travel circuits
 Maximum flow 535 l/min
 Supply for control circuit Self-reducing valve
 Hydraulic motors:
 Travel 2 × axial piston motor with parking brake
 Swing 1 × axial piston motor with swing holding brake
 Relief valve setting:
 Implement circuits 37.3 MPa / 380 kg/cm²
 Travel circuit 37.3 MPa / 380 kg/cm²
 Swing circuit 27.9 MPa / 285 kg/cm²
 Pilot circuit 3.2 MPa / 33 kg/cm²
 Hydraulic cylinders:
 (Number of cylinders – bore × stroke × rod diameter)
 Boom 2–140 mm × 1480 mm × 100 mm
 Arm 1–160 mm × 1825 mm × 110 mm
 Bucket for 3.19 m arm 1–140 mm × 1285 mm × 100 mm
 for 2.55 m and 2.20 m arm 1–150 mm × 1285 mm × 110 mm



Drives and brakes

Steering control Two levers with pedals
 Drive method Hydrostatic
 Maximum drawbar pull 264 kN / 26900 kg
 Gradeability 70%, 35°
 Maximum travel speed:
 High 5.5 km/h
 (Auto-shift) Mid 4.5 km/h
 (Auto-shift) Low 3.2 km/h
 Service brake Hydraulic lock
 Parking brake Mechanical disc brake



Swing system

Drive method Hydrostatic
 Swing reduction Planetary gear
 Swing circle lubrication Grease-bathed
 Service brake Hydraulic lock
 Holding brake/swing lock Mechanical disc brake
 Swing speed 9.5 rpm



Undercarriage

Center frame X-frame
 Track frame Box-section
 Seal of track Sealed track
 Track adjuster Hydraulic
 Number of shoes (each side):
 PC350-8M0 45
 PC350LC-8M0 48
 Number of carrier rollers (each side) 2
 Number of track rollers (each side):
 PC350-8M0 7
 PC350LC-8M0 8



Coolant and lubricant capacity (refilling)

Fuel tank 605 l
 Coolant 31.0 l
 Engine 37.0 l
 Final drive (each side) 9.0 l
 Swing drive 16.5 l
 Hydraulic tank 188 l



Operating weight (approximate)

Operating weight including 6470 mm one-piece boom, 3185 mm arm, SAE J 296 heaped 1.40 m³ backhoe bucket, rated capacity of lubricants, coolant, full fuel tank, operator, and standard equipment.

Shoes	PC350-8M0		PC350LC-8M0	
	Operating weight	Ground pressure	Operating weight	Ground pressure
600 mm	32600 kg	65.7 kPa 0.67 kg/cm ²	33660 kg	62.9 kPa 0.64 kg/cm ²
700 mm	32960 kg	57.1 kPa 0.58 kg/cm ²	34040 kg	54.5 kPa 0.56 kg/cm ²

Operating weight including 6000 mm one-piece boom, 2550 mm arm, SAE J 296 heaped 1.90 m³ backhoe bucket, rated capacity of lubricants, coolant, full fuel tank, operator, and standard equipment.

Shoes	PC350-8M0 SE Spec.		PC350LC-8M0 SE Spec.	
	Operating weight	Ground pressure	Operating weight	Ground pressure
600 mm	32900 kg	65.7 kPa 0.67 kg/cm ²	34000 kg	62.9 kPa 0.64 kg/cm ²



Dimensions & working range

Model		PC350-8M0 / PC350LC-8M0	PC350-8M0 SE Spec. / PC350LC-8M0 SE Spec.	
Boom length		6470 mm	6000 mm	
Arm length		3185 mm	2200 mm	2550 mm
A	Overall length	11140 mm	10835 mm	10710 mm
B	Length on ground	5755 mm / 5930 mm	4485 mm	3660 mm
C	Overall height (to top of boom)*	3285 mm	3710 mm	3505 mm
D	Overall width	3190 mm		
E	Overall height (to top of cab)*	3145 mm		
F	Ground clearance, counterweight	1185 mm		
G	Ground clearance (minimum)	500 mm		
H	Tail swing radius	3450 mm		
I	Track length on ground	3700 mm / 4030 mm	3700 mm / 4030 mm	
J	Track length	4625 mm / 4955 mm	4625 mm / 4955 mm	
K	Track gauge	2590 mm		
L	Width of crawler	3190 mm		
M	Shoe width	600 mm		
N	Grouser height	36 mm		
O	Machine cab height	2585 mm		
P	Machine cab width	3165 mm		
Q	Distance, swing center to rear end	3405 mm		
R	Max. digging height	10100 mm	8995 mm	9525 mm
S	Max. dumping height	7050 mm	6200 mm	6575 mm
T	Max. digging depth	7380 mm	5955 mm	6310 mm
U	Max. vertical wall digging depth	6400 mm	4640 mm	5625 mm
V	Max. digging depth of cut for 2440 mm level	7180 mm	5705 mm	6115 mm
W	Max. digging reach	11100 mm	9620 mm	10065 mm
X	Max. digging reach at ground level	10920 mm	9410 mm	9860 mm
Y	Min. swing radius	4310 mm	4080 mm	4065 mm
SAE 1179 Rating	Bucket digging force at Power max.	200 kN 20400 kg	228 kN 23300 kg	228 kN 23300 kg
	Arm crowd force at Power max.	165 kN 16800 kg	225 kN 22900 kg	193 kN 19700 kg
ISO 6015 Rating	Bucket digging force at Power max.	228 kN 23200 kg	259 kN 26400 kg	259 kN 26400 kg
	Arm crowd force at Power max.	171 kN 17400 kg	235 kN 24000 kg	201 kN 20500 kg

* Including grouser height

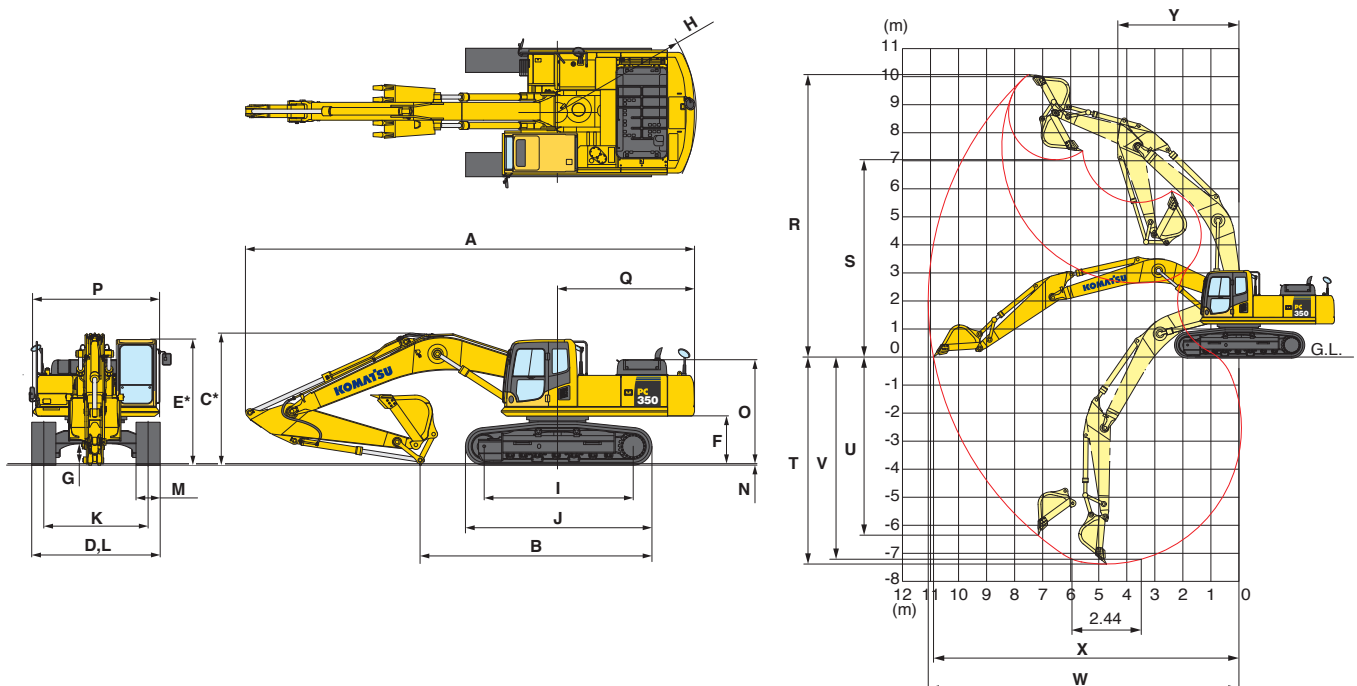



Lifting capacity with lifting mode

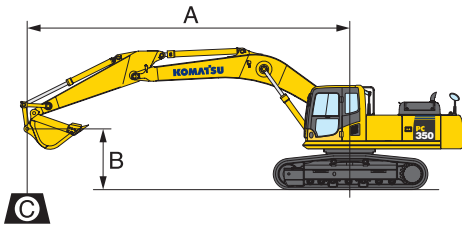

PC350-8M0 / PC350LC-8M0

- A: Reach from swing center
- B: Bucket hook height
- C: Lifting capacity
- Cf: Rating over front
- Cs: Rating over side
- ⊗: Rating at maximum reach

PC350-8M0 Boom: 6470 mm Arm: 3185 mm Bucket: 1.40 m³ SAE J 296 heaped Shoe: 600 mm triple grouser													
B	A	⊗ MAX		9.0 m		7.5 m		6.0 m		4.5 m		3.0 m	
		Cf	Cs	Cf	Cs	Cf	Cs	Cf	Cs	Cf	Cs	Cf	Cs
7.5 m		*4900 kg	*4900 kg			*6400 kg	5550 kg						
6.0 m		*4800 kg	3950 kg			*6750 kg	5500 kg						
4.5 m		*4950 kg	3350 kg	5500 kg	3600 kg	*7300 kg	5250 kg	*8700 kg	7950 kg				
3.0 m		4750 kg	3050 kg	5350 kg	3450 kg	7450 kg	4950 kg	*10100 kg	7400 kg	*14400 kg	11950 kg		
1.5 m		4600 kg	2900 kg	5150 kg	3300 kg	7150 kg	4700 kg	10400 kg	6850 kg	*16100 kg	10850 kg		
0 m		4700 kg	2950 kg	5050 kg	3200 kg	6900 kg	4450 kg	10000 kg	6500 kg	16400 kg	10300 kg		
-1.5 m		5100 kg	3200 kg	5000 kg	3150 kg	6750 kg	4350 kg	9800 kg	6300 kg	16200 kg	10150 kg	*9050 kg	*9050 kg
-3.0 m		5900 kg	3800 kg			6750 kg	4350 kg	9800 kg	6300 kg	*14900 kg	10250 kg	*17300 kg	*17300 kg
-4.5 m		*6950 kg	5050 kg					*9200 kg	6500 kg	*12250 kg	10550 kg	*15900 kg	*15900 kg
-6.0 m		*5700 kg	*5700 kg							*7550 kg	*7550 kg		

PC350LC-8M0 Boom: 6470 mm Arm: 3185 mm Bucket: 1.40 m³ SAE J 296 heaped Shoe: 600 mm triple grouser													
B	A	⊗ MAX		7.5 m		6.0 m		4.5 m		3.0 m		1.5 m	
		Cf	Cs	Cf	Cs	Cf	Cs	Cf	Cs	Cf	Cs	Cf	Cs
7.5 m		*4900 kg	*4900 kg			*6400 kg	5750 kg						
6.0 m		*4800 kg	4100 kg			*6750 kg	5650 kg						
4.5 m		*4950 kg	3500 kg	6350 kg	3750 kg	*7300 kg	5450 kg	*8700 kg	8150 kg				
3.0 m		*5300 kg	3150 kg	6200 kg	3600 kg	*8100 kg	5100 kg	*10100 kg	7600 kg	*14400 kg	12250 kg		
1.5 m		5400 kg	3050 kg	6050 kg	3450 kg	8300 kg	4850 kg	*11400 kg	7100 kg	*16100 kg	11150 kg		
0 m		5500 kg	3100 kg	5900 kg	3300 kg	8050 kg	4650 kg	11700 kg	6700 kg	*16900 kg	10600 kg		
-1.5 m		5950 kg	3350 kg	5850 kg	3250 kg	7950 kg	4500 kg	11500 kg	6500 kg	*16400 kg	10450 kg	*9050 kg	*9050 kg
-3.0 m		6950 kg	3900 kg			7950 kg	4500 kg	*11150 kg	6500 kg	*14900 kg	10600 kg	*17300 kg	*17300 kg
-4.5 m		*6950 kg	5200 kg					*9200 kg	6700 kg	*12250 kg	10850 kg	*15900 kg	*15900 kg
-6.0 m		*5700 kg	*5700 kg							*7550 kg	*7550 kg		

* Load is limited by hydraulic capacity rather than tipping. Ratings are based on SAE J1097. Rated loads do not exceed 87% of hydraulic lift capacity or 75% of tipping load.



Lifting capacity with lifting mode

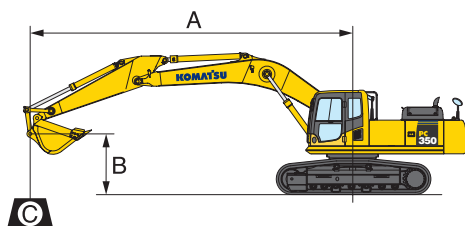

PC350-8M0 SE Spec. / PC350LC-8M0 SE Spec.

- A: Reach from swing center
- B: Bucket hook height
- C: Lifting capacity
- Cf: Rating over front
- Cs: Rating over side
- ⊗: Rating at maximum reach

PC350LC-8M0 Boom: 6000 mm Arm: 2550 mm Me Bucket: 1.90 m ³ SAE J 296 heaped Shoe: 600 mm triple grouser											
B	A	⊗ MAX		7.5 m		6.0 m		4.5 m		3.0 m	
		Cf	Cs	Cf	Cs	Cf	Cs	Cf	Cs	Cf	Cs
7.5 m		*7150 kg	*7150 kg								
6.0 m		*6950 kg	5350 kg	*7400 kg	5400 kg	*8550 kg	8400 kg				
4.5 m		*7150 kg	4400 kg	*8100 kg	5300 kg	*9500 kg	8050 kg	*12250 kg	*12250 kg		
3.0 m		6750 kg	3950 kg	8500 kg	5050 kg	*10800 kg	7500 kg	*15200 kg	12150 kg		
1.5 m		6550 kg	3750 kg	8250 kg	4800 kg	*11850 kg	7050 kg	*17050 kg	11200 kg		
0 m		6750 kg	3850 kg	8050 kg	4650 kg	11750 kg	6750 kg	*17050 kg	10750 kg	*9500 kg	*9500 kg
-1.5 m		7500 kg	4300 kg	7950 kg	4550 kg	11600 kg	6600 kg	*15950 kg	10700 kg	*11550 kg	*11550 kg
-3.0 m		*7900 kg	5350 kg			*10150 kg	6700 kg	*13650 kg	10900 kg	*17400 kg	*17400 kg
-4.5 m		*6850 kg	*6850 kg					*9500 kg	*9500 kg	*11750 kg	*11750 kg

PC350-8M0 Boom: 6000 mm Arm: 2550 mm Me Bucket: 1.90 m ³ SAE J 296 heaped Shoe: 600 mm triple grouser											
B	A	⊗ MAX		7.5 m		6.0 m		4.5 m		3.0 m	
		Cf	Cs	Cf	Cs	Cf	Cs	Cf	Cs	Cf	Cs
7.5 m		*7150 kg	7000 kg								
6.0 m		*6950 kg	5150 kg	*7400 kg	5250 kg	*8550 kg	8200 kg				
4.5 m		6400 kg	4250 kg	7600 kg	5150 kg	*9500 kg	7800 kg	*12250 kg	*12250 kg		
3.0 m		5800 kg	3800 kg	7350 kg	4900 kg	*10800 kg	7300 kg	*15200 kg	11850 kg		
1.5 m		5600 kg	3650 kg	7050 kg	4650 kg	10350 kg	6850 kg	16800 kg	10900 kg		
0 m		5800 kg	3700 kg	6900 kg	4450 kg	10000 kg	6550 kg	16500 kg	10450 kg	*9500 kg	*9500 kg
-1.5 m		6400 kg	4150 kg	6800 kg	4400 kg	9900 kg	6400 kg	*15950 kg	10400 kg	*11550 kg	*11550 kg
-3.0 m		*7900 kg	5150 kg			9950 kg	6500 kg	*13650 kg	10600 kg	*17400 kg	*17400 kg
-4.5 m		*6850 kg	*6850 kg					*9500 kg	*9500 kg	*11750 kg	*11750 kg

PC350LC-8M0 Boom: 6000 mm Arm: 2200 mm Me Bucket: 2.10 m ³ SAE J 296 heaped Shoe: 600 mm triple grouser											
B	A	⊗ MAX		7.5 m		6.0 m		4.5 m		3.0 m	
		Cf	Cs	Cf	Cs	Cf	Cs	Cf	Cs	Cf	Cs
7.5 m		*8850 kg	8600 kg								
6.0 m		*8350 kg	6000 kg			*8800 kg	8100 kg				
4.5 m		8150 kg	4800 kg	*8200 kg	5000 kg	*9650 kg	7750 kg	*12600 kg	*12600 kg	*15600 kg	*15600 kg
3.0 m		7350 kg	4200 kg	8250 kg	4800 kg	*10850 kg	7200 kg	*15100 kg	11700 kg		
1.5 m		7100 kg	4000 kg	8000 kg	4550 kg	11750 kg	6750 kg	*16750 kg	10800 kg		
0 m		7350 kg	4100 kg	7850 kg	4400 kg	11500 kg	6500 kg	*16550 kg	10500 kg		
-1.5 m		8300 kg	4650 kg	7800 kg	4400 kg	*11250 kg	6400 kg	*15150 kg	10550 kg	*16800 kg	*16800 kg
-3.0 m		*8300 kg	6050 kg			*9300 kg	6550 kg	*12550 kg	10750 kg	*15050 kg	*15050 kg
-4.5 m		*6700 kg	*6700 kg					*7800 kg	*7800 kg		

PC350-8M0 Boom: 6000 mm Arm: 2200 mm Me Bucket: 2.10 m ³ SAE J 296 heaped Shoe: 600 mm triple grouser											
B	A	⊗ MAX		7.5 m		6.0 m		4.5 m		3.0 m	
		Cf	Cs	Cf	Cs	Cf	Cs	Cf	Cs	Cf	Cs
7.5 m		*8850 kg	8400 kg								
6.0 m		*8350 kg	5800 kg			*8800 kg	7900 kg				
4.5 m		7050 kg	4650 kg	7350 kg	4850 kg	*9650 kg	7500 kg	*12600 kg	12550 kg	*15600 kg	*15600 kg
3.0 m		6300 kg	4050 kg	7100 kg	4650 kg	10550 kg	7000 kg	*15100 kg	11400 kg		
1.5 m		6050 kg	3850 kg	6850 kg	4400 kg	10100 kg	6550 kg	16600 kg	10500 kg		
0 m		6250 kg	3950 kg	6700 kg	4250 kg	9800 kg	6300 kg	16250 kg	10150 kg		
-1.5 m		7050 kg	4500 kg	6650 kg	4250 kg	9700 kg	6200 kg	*15150 kg	10250 kg	*16800 kg	*16800 kg
-3.0 m		*8300 kg	5850 kg			*9300 kg	6350 kg	*12550 kg	10450 kg	*15050 kg	*15050 kg
-4.5 m		*6700 kg	*6700 kg					*7800 kg	*7800 kg		

* Load is limited by hydraulic capacity rather than tipping. Ratings are based on SAE J1097. Rated loads do not exceed 87% of hydraulic lift capacity or 75% of tipping load.



Standard equipment

Engine

- Automatic engine warm-up system
- Dry type air cleaner, double element
- Engine, Komatsu SAA6D114E-3
- Engine overheat prevention system
- Radiator and oil cooler dust proof net
- Suction fan

Electrical system

- Alternator, 24 V/60 A
- Auto-decelerator
- Batteries, 2 × 12 V/126 Ah
- Starting motor, 24 V/7.5 kW
- Working light, 2 (boom and rh)

Hydraulic system

- Boom holding valve
- Long lubricating intervals for implement bushing
- Power maximizing system

- Pressure Proportional Control (PPC) hydraulic control system
- Two-mode settings for boom
- Working mode selection system

Guards and covers

- Fan guard structure

Undercarriage

- Hydraulic track adjusters (each side)
- Track roller
 - PC350-8M0, 7 each side
 - PC350LC-8M0, 8 each side
- Track roller guards (full length)
- Track shoe
 - PC350-8M0, 600 mm triple grouser
 - PC350LC-8M0, 600 mm triple grouser

Operator environment

- A/C with defroster
- Cab with 2-piece pull up front window
- Multi-function color monitor
- Rear view mirror, RH, LH, rear, sidewise
- ROPS cab (ISO 12117-2)
- Seat belt, retractable
- Skylight

Other equipment

- Counterweight
- Electric horn
- Rear reflector
- Slip-resistant plates
- Travel alarm



Optional equipment

Engine

- Additional filter system for poor-quality fuel (water separator)
- Large capacity fuel pre-filter



Electrical system

- Batteries, 2 × 12 V/140 Ah
- Working lights (2 on cab)

Hydraulic system

- Service valve

Undercarriage

- Shoes, triple grouser shoes
 - PC350-8M0, 700 mm
 - PC350LC-8M0, 700 mm
- Track frame undercover

Operator environment

- Bolt-on top guard, OPG top guard level 2 (ISO 10262)
- Cab accessories
 - Rain visor
 - Sun visor
- Cab front guard
 - Full height guard, OPG level 1 (ISO 10262)

- Full height guard, OPG level 2 (ISO 10262)
- Half height guard
- Cab with fixed front window
- Fixed skylight and sunshade
- Rear view monitor system
- Seat, suspension

Work equipment

- Arms
 - 2220 mm arm assembly, heavy duty
 - 2550 mm arm assembly, heavy duty
 - 3185 mm arm assembly, heavy duty
- Booms
 - 6000 mm
 - 6470 mm

Other equipment

- Electric grease gun
- Fuel refill pump

Your Komatsu partner:

KOMATSU

komatsu.com