

English for Life

---

# Meet Jesus

Ten Bible-based English lessons

---

## Volume 2 High Beginner

Written by Sarah Brown  
Illustrations by Ivan Smith

---

# Lesson 16

## **PART 1** (APPROX 1 HOUR):

**Halving things**

## **PART 2** (APPROX 1/2 HOUR):

**Jesus dies on the cross**  
**Mark 15:24–39**

 **Prepare lesson**

## Part 1. Halving things

### Print resources

- RESOURCE 16.1 – Midday or midnight strips**  
Print one copy and cut up. Attach Blu Tack or similar product to back of each strip.
- RESOURCE 16.2 – Midday or midnight worksheet**  
Print one copy per student.
- RESOURCE 16.3 – Circle**  
Print one copy, or remove this page from this book and cut out the circle.
- RESOURCE 16.4 – Find the other half**  
Print one copy and cut up.

### Additional equipment

- Blu Tack or similar reusable adhesive
- Analog clock (if available)

## Part 2. Jesus dies on the cross

### Read scripture

- Mark 15:24–39 in NIV Bible  
(or another easy-to-read translation)

### Print resources (on the next page)

## Print resources

- Heart language Bible text**  
Print one text per student in relevant languages from [bible.com](http://bible.com) or [biblegateway.com](http://biblegateway.com)
- RESOURCE 16.5 – Large sketches**  
Print one set of A4 sketches to display.
- RESOURCE 16.6 – Large sentences**  
Print one set of A4 sentences to display.
- RESOURCE 16.7 – Small sketches**  
Print one copy per pair and cut up.
- RESOURCE 16.8 – Small sentence strips**  
Print one copy per pair and cut up.
- RESOURCE 16.9 – Gap-fill worksheet**  
Print one copy per student.

## Select Variations to activities

(see pages 4–5)

## Part 1. Halving things

### Activate knowledge

**Draw** a vertical line down the centre of the board.

**Write** *midday* at the top of the left side.

**Write** *midnight* at the top of the right column.

**Ask** 'What's midday?'

**Invite** responses.

**Ask** 'What's midnight?'

**Invite** responses.

**Distribute** one strip of paper (with Blu Tack on the back) from **RESOURCE 16.1 – Midday or midnight strips** to each student. (**Note:** some of these are easier than others. If possible, consider students' abilities/levels of experience when distributing.)

**Invite** each student to place their word in the correct column on the board underneath *midday* or *midnight*.

**Remove** the paper strips from the board before the next activity.

**RESOURCE 16.1 –  
Midday or midnight  
strips**

**Print one copy and cut  
up. Attach Blu Tack or  
similar product to back  
of each strip.**

### Focus on language

#### Activity 1: Midday or midnight?

**Distribute** **RESOURCE 16.2 – Midday or midnight worksheet** to each student.

**Encourage** students to work together to complete the worksheet.

**Check** the answers together by placing the strips from **RESOURCE 16.1 – Midday or midnight strips** in the correct columns on the board again.

**RESOURCE 16.2 –  
Midday or midnight  
worksheet**

**Print one copy per  
student.**

## Activity 2: Half past the hour

**Display** an analog clock if available or draw an analog clock without hands on the board. (Depending on the level of your students, you can draw 12 dots around the clock [not numbers] or just four dots in the 3, 6, 9 and 12 positions.)

**Ask** 'What is 12 o'clock?'

**Invite** a volunteer to correctly position the hands on the clock (either physically or by drawing on the board).

**Ask** 'What is half past 12?'

**Invite** a volunteer to correctly position the hands on the clock (either physically or by drawing on the board).

**Repeat** using different times until all students are confident with indicating half past the hour. (**Note:** You can extend this activity by introducing students to the concept of quarters, including a quarter past and a quarter to the hour.)

## Activity 3: Halving things

**Display** RESOURCE 16.3 – Circle.

**Say** 'Fold the circle in half.'

**Invite** a volunteer to demonstrate.

**Say** 'The circle was halved.'

**Write** the following on the board:

- half (noun)*
- halve (verb)*

**Practise** correct pronunciation together.

### RESOURCE 16.3 – Circle

Print one copy, or  
remove this page from  
this book and cut out  
the circle.

**RESOURCE 16.4 –  
Find the other half**

Print one copy and  
cut up.

**Activity 4: Find the other half**

**Distribute** cut-up halves from **RESOURCE 16.4 – Find the other half** among students – one half per student.

**Invite** students to find the person with the other half.

**Invite** the pairs that have formed to sit together and tell the class what item they have – for example, 'I have half a band-aid'; 'We have a button'.

**Invite** pairs to brainstorm the names of items that can be halved (e.g. consider food, numbers, shapes).

## Part 2 – Jesus dies on the cross

### Mark 15:24–39

#### Read for gist

**Hold up** a hard copy of the Bible.

**Say** ‘In the Bible story, a curtain tears in half.’

**Distribute** copies of Mark 15:24–39 in your students’ heart languages and allow time for students to read silently for context, then ask them to put the text away for the rest of the lesson.

#### Read for detail

**Display** [RESOURCE 16.5 – Large sketches](#) in order.

**Read** the sentences below slowly, pointing to the corresponding sketches as you read.

#### **Sentences:**

1. Jesus was nailed to a cross.
2. It was midday.
3. The sky was dark for three hours.
4. Jesus shouted, ‘God, why have you left me?’
5. Jesus died.
6. The curtain in the temple tore in half.
7. An officer said, ‘This man was God.’

**Re-read** the sentences, placing the correct sentence from [RESOURCE 16.6 – Large sentences](#) near each sketch as you go.

**Read** the sentences again and invite students to point to the corresponding sketches as you read.

**RESOURCE 16.5 –  
Large sketches**

**Print** one set of A4 sketches to display.

**RESOURCE 16.6 –  
Large sentences**

**Print** one set of A4 sentences to display.



 **Reinforce the language**

**Divide** students into pairs.

**Distribute** **RESOURCE 16.7 – Small sketches** to pairs.

**Invite** pairs to sequence the sketches in the correct order.

**Distribute** **RESOURCE 16.8 – Small sentence strips** to pairs.

**Invite** pairs to match the sentence strips to the corresponding sketches. (More advanced students can sequence the sentence strips without looking at the sketches.)

**Invite** students to retell the story to their partners.

**Invite** confident students to retell the story to the whole class using only the sketches.

**Reinforce** the text using some of the six **Variations to activities** on pages 4–5.

**Distribute** **RESOURCE 16.9 – Gap-fill worksheet** to each student.

**Encourage** students to work together to complete the worksheet.

**Check** answers together by reading slowly through the worksheet and writing the missing words on the board.

**RESOURCE 16.7 –  
Small sketches**

Print one copy per pair  
and cut up.

**RESOURCE 16.8 –  
Small sentence strips**

Print one copy per pair  
and cut up.

**RESOURCE 16.9 –  
Gap-fill worksheet**

Print one copy per  
student.

16.1 RESOURCE – Midday or midnight strips

Lesson 16: Part 1. Halving things  
Print one copy and cut up. Attach Blu Tack  
or similar product to back of each strip.

12 o'clock	12 o'clock
day	night
lunch time	sleep time
light	dark
12pm	12am
1200 hours	2400 hours
sun	moon and stars

## 16.2 RESOURCE – Midday or midnight worksheet

Lesson 16: Part 1. Halving things  
Print one copy per student.

Write the words from the box in the correct columns in the table below.

2400 hours	12 o'clock	moon and stars
night	day	12 o'clock
12am	light	1200 hours
sun	sleep time	dark
12pm	lunch time	

Midday	Midnight

## 16.3 RESOURCE – Circle

Lesson 16: Part 1. Halving things  
Print one copy, or remove this page  
from the book and cut out the circle.

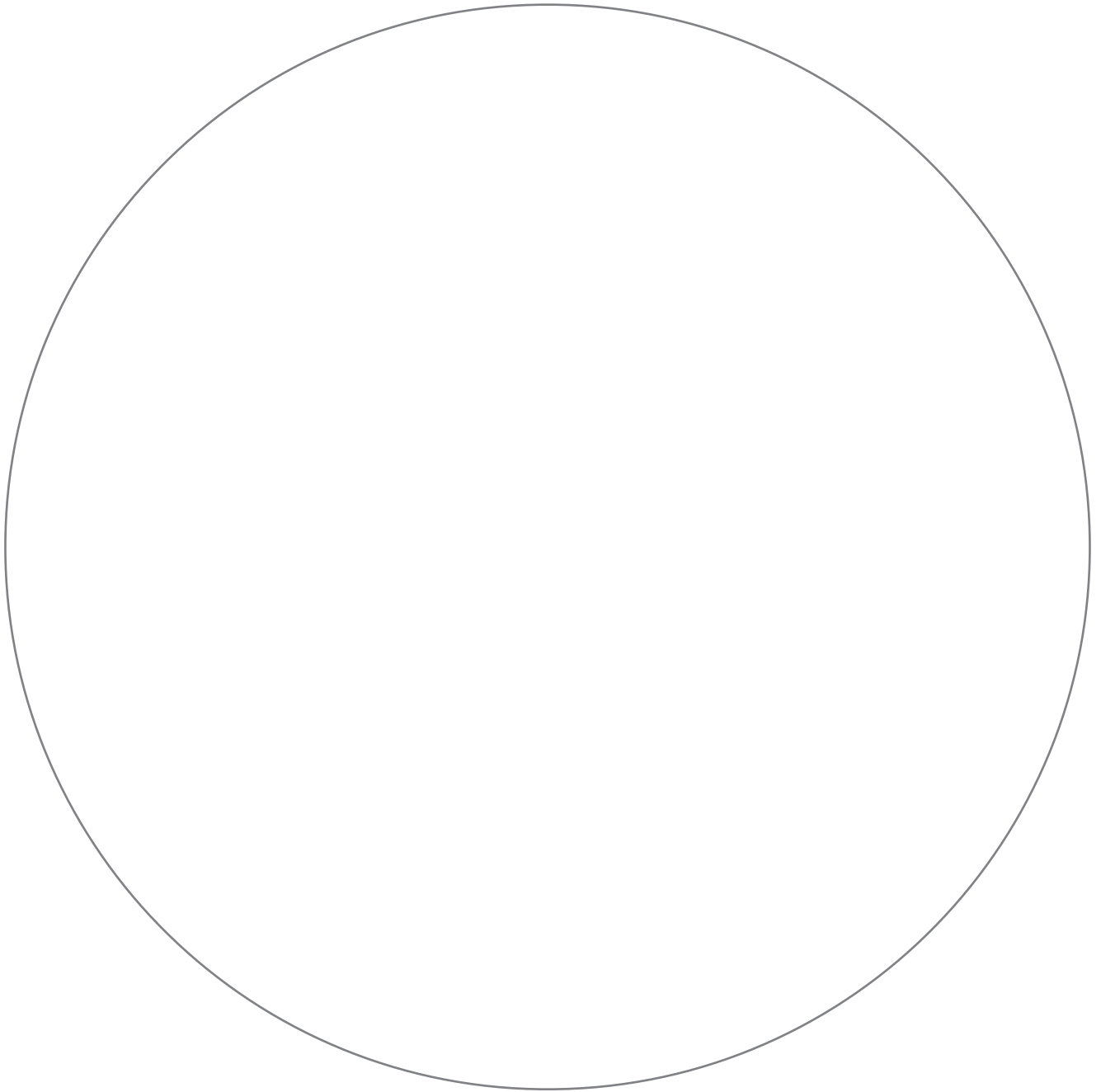

16.4 RESOURCE – Find the other half

Lesson 16: Part 1. Halving things  
Print one copy and cut up.  
(Note: resource spans three pages.)

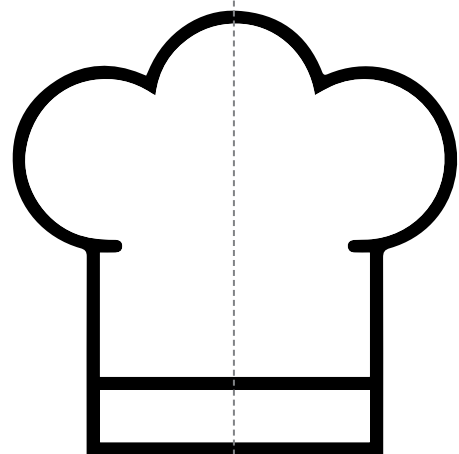
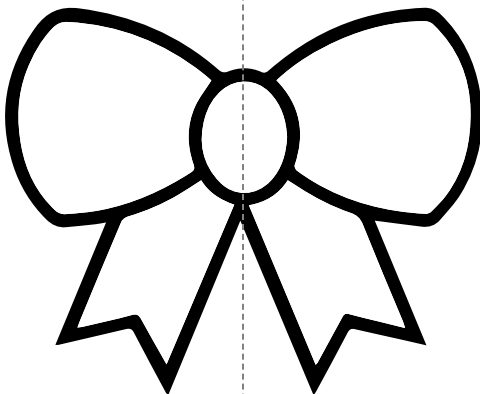
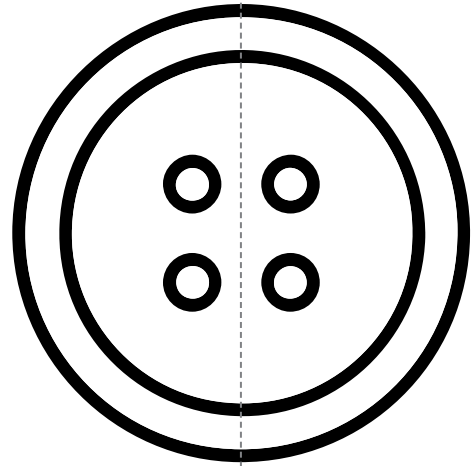
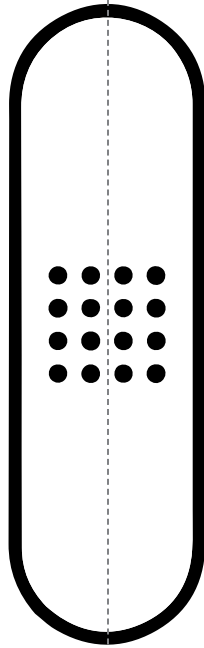

16.4 RESOURCE – Find the other half

Lesson 16: Part 1. Halving things  
Print one copy and cut up.  
(Note: resource spans three pages.)

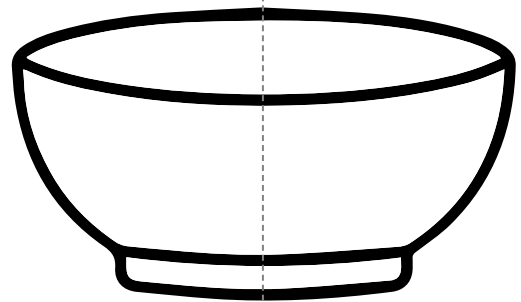
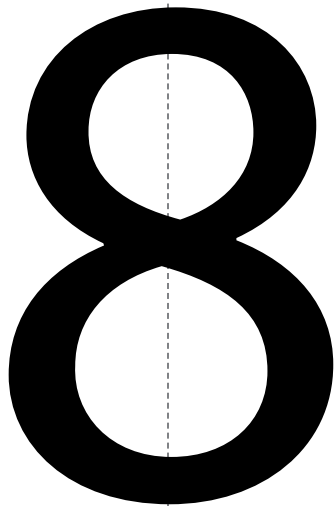
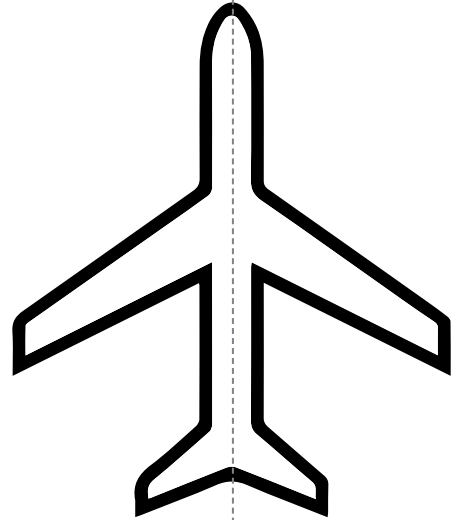
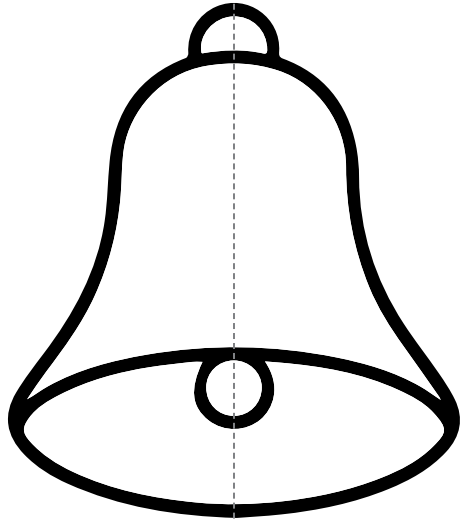

16.4 RESOURCE – Find the other half

Lesson 16: Part 1. Halving things  
Print one copy and cut up.  
(Note: resource spans three pages.)

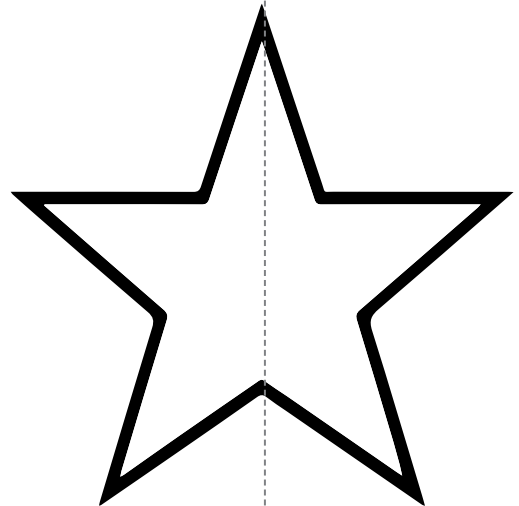
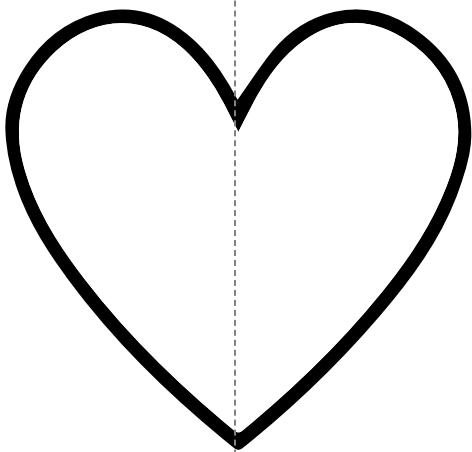
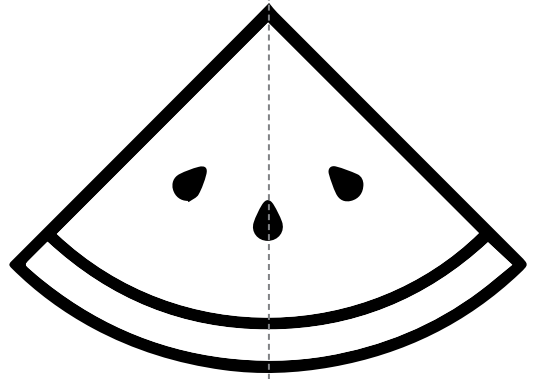
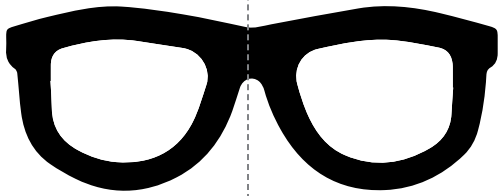





16.5 RESOURCE –  
Large sketches

Lesson 16: Part 2. Jesus dies on the cross – Mark 15:24-39  
Print one set of A4 sketches to display.

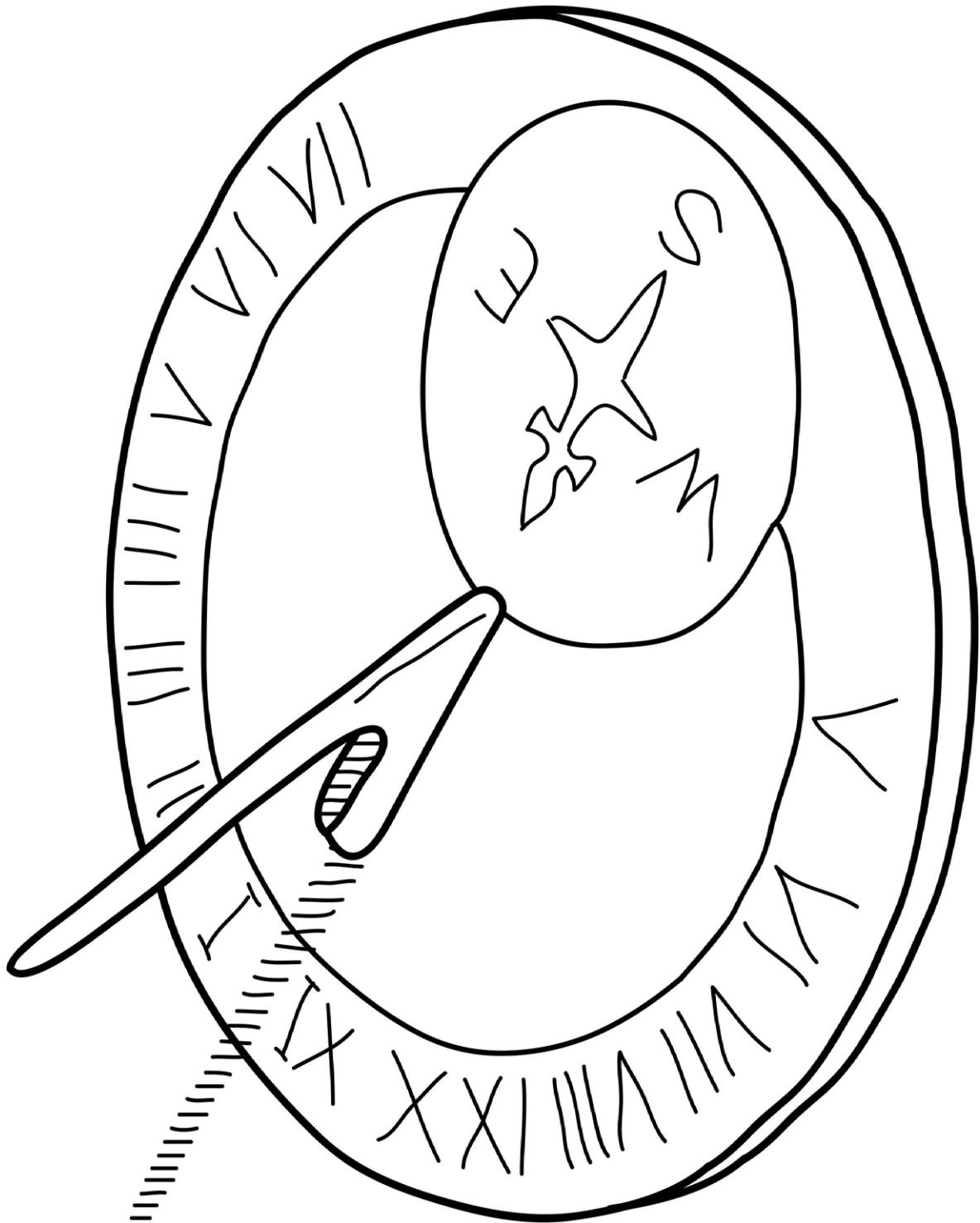

16.5 RESOURCE –  
Large sketches

Lesson 16: Part 2. Jesus dies on the cross – Mark 15:24–39  
Print one set of A4 sketches to display.

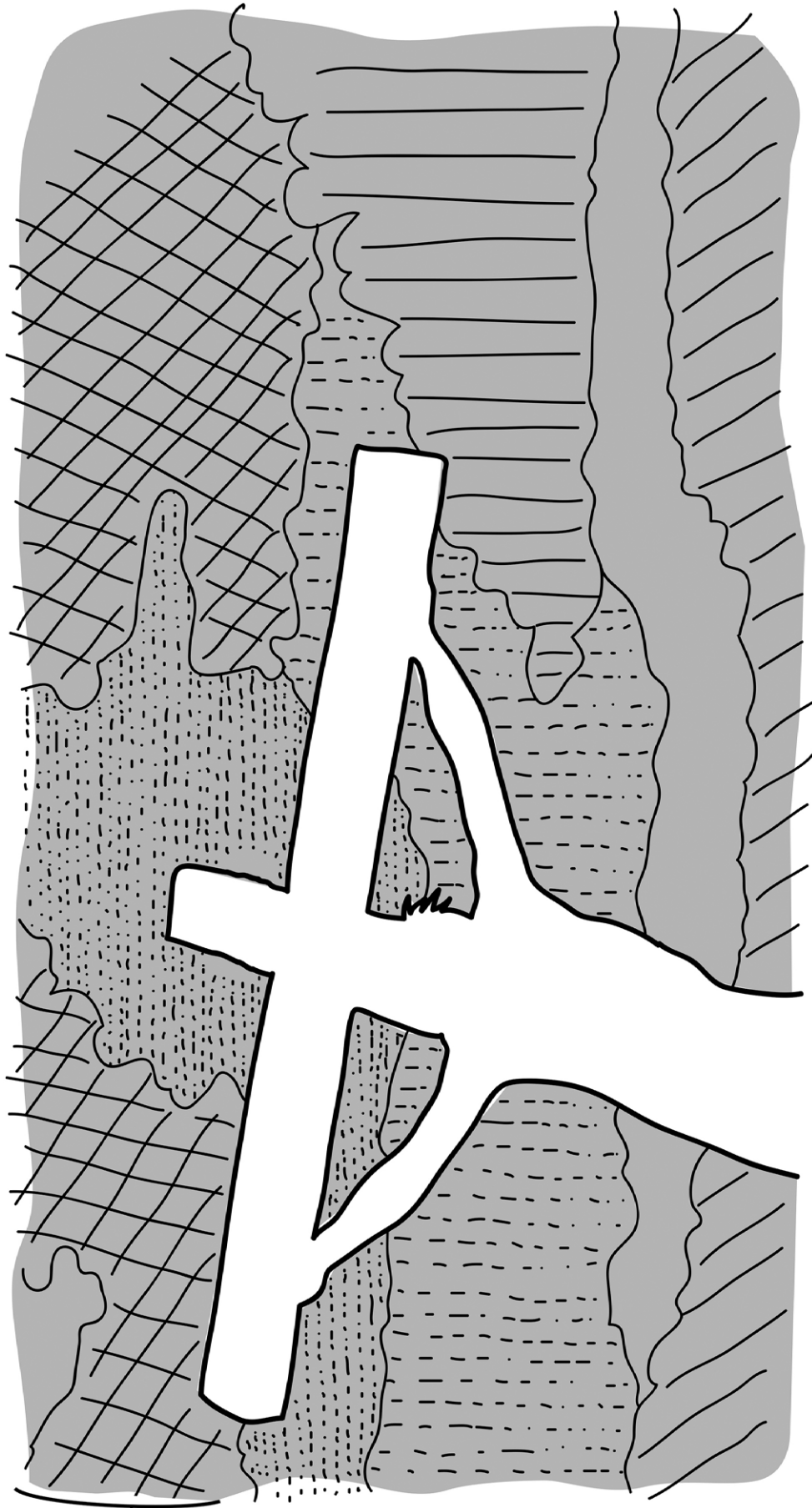

16.5 RESOURCE –  
Large sketches

Lesson 16: Part 2. Jesus dies on the cross – Mark 15:24–39  
Print one set of A4 sketches to display.

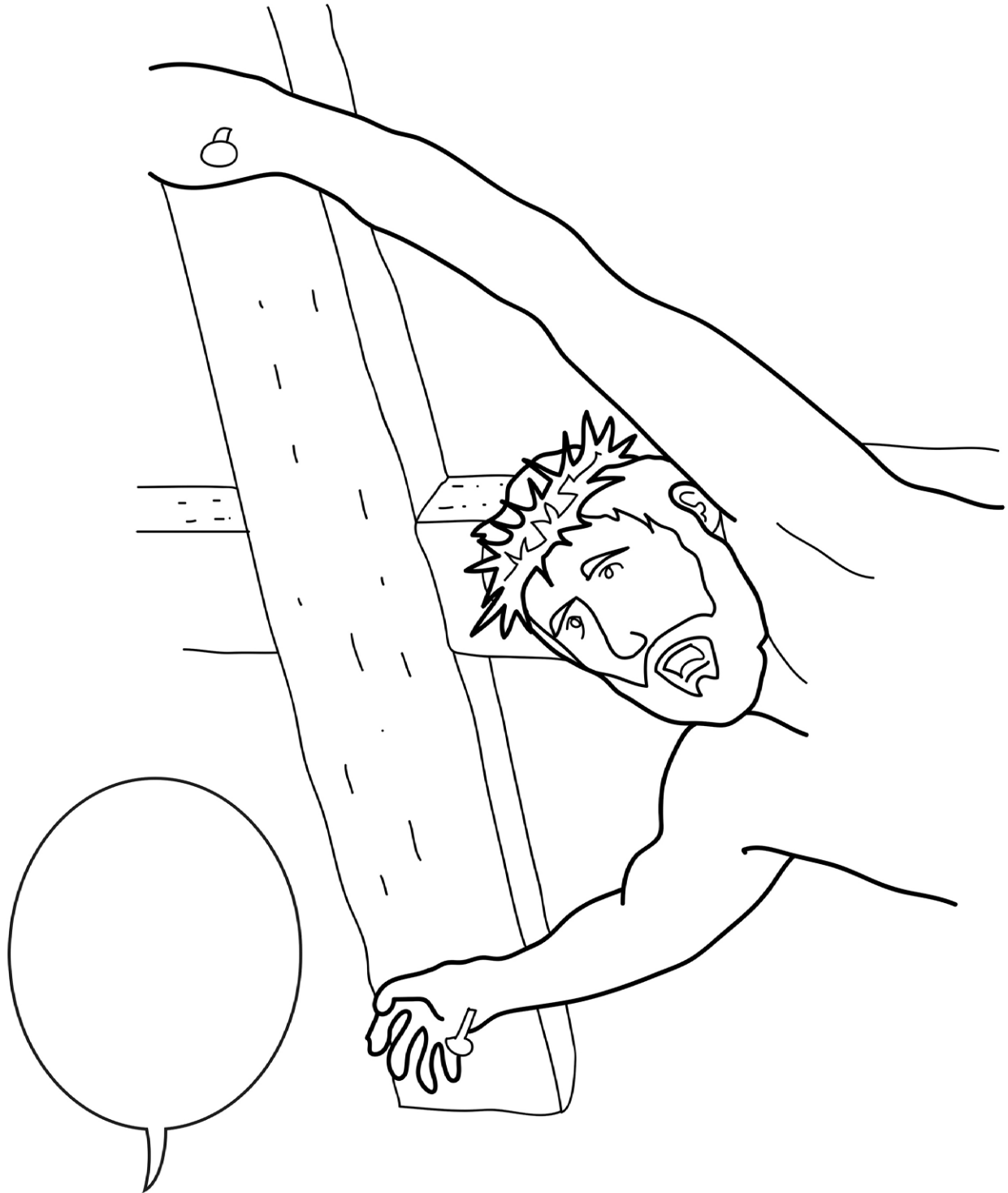

16.5 RESOURCE –  
Large sketches

Lesson 16: Part 2. Jesus dies on the cross – Mark 15:24–39  
Print one set of A4 sketches to display.

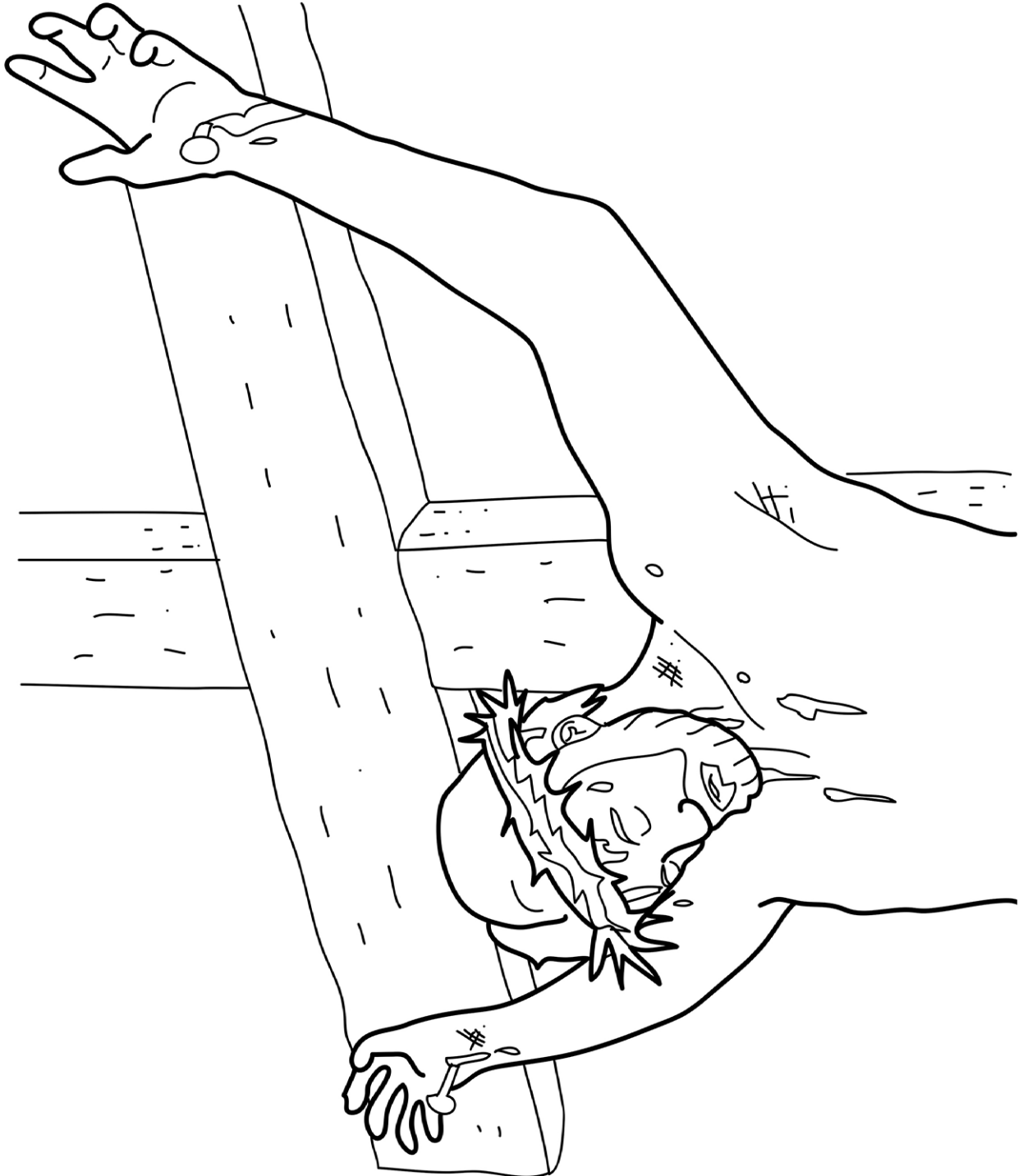

16.5 RESOURCE –  
Large sketches

Lesson 16: Part 2. Jesus dies on the cross – Mark 15:24–39  
Print one set of A4 sketches to display.

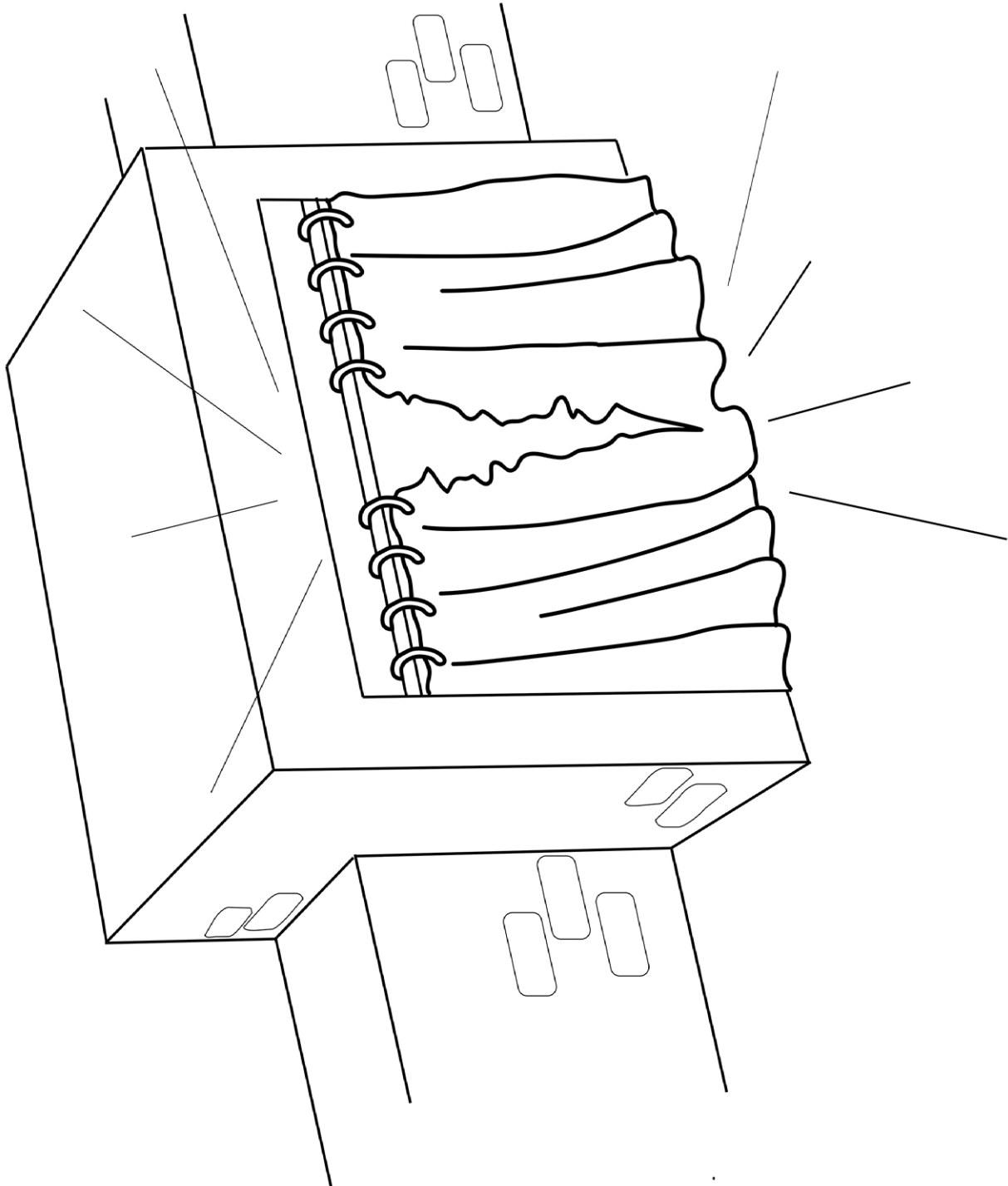

16.5 RESOURCE –  
Large sketches

Lesson 16: Part 2. Jesus dies on the cross – Mark 15:24–39  
Print one set of A4 sketches to display.



**Jesus was  
nailed to a  
cross.**

**It was midday.**



**The sky was  
dark for three  
hours.**

**Jesus shouted,  
'God, why  
have you left  
me?'**

**Jesus died.**

**The curtain in  
the temple tore  
in half.**

**An officer said,  
'This man was  
God!'**

16.7 RESOURCE –  
Small sketches

Lesson 16: Part 2. Jesus dies on the cross – Mark 15:24–39  
Print one copy per pair and cut up.



Meet Jesus.HB.16



Meet Jesus.HB.16

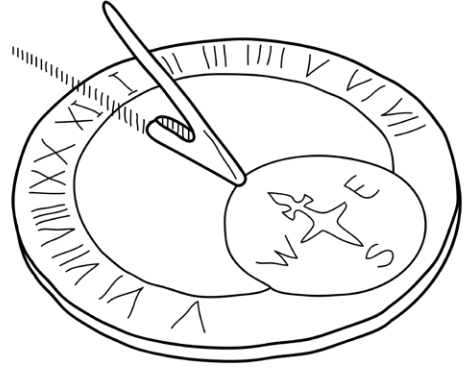

Meet Jesus.HB.16

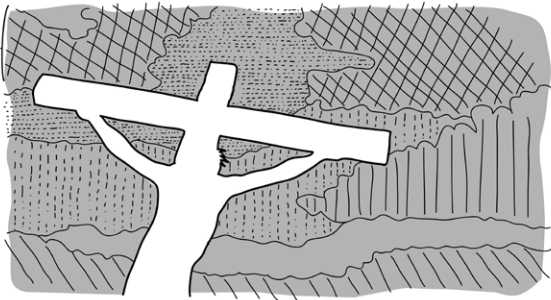

Meet Jesus.HB.16

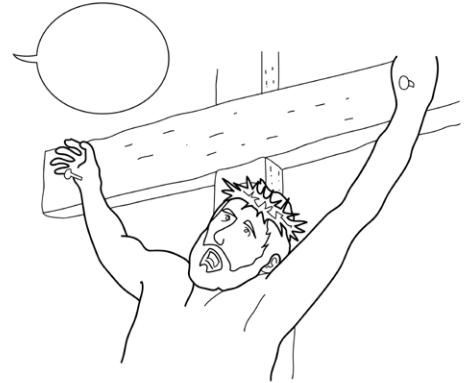

Meet Jesus.HB.16



Meet Jesus.HB.16

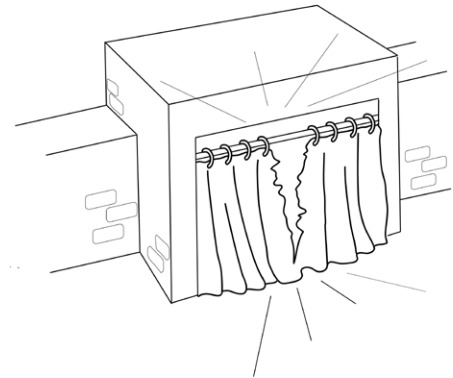

Meet Jesus.HB.16



**16.8 RESOURCE – Small sentence strips**

Lesson 16: Part 2. Jesus dies on the cross – Mark 15:24–39  
Print one copy per pair and cut up.



Meet Jesus.HB.16

Jesus was nailed to a cross.

Meet Jesus.HB.16

It was midday.

Meet Jesus.HB.16

The sky was dark for three hours.

Meet Jesus.HB.16

Jesus shouted, 'God, why have you left me?'

Meet Jesus.HB.16

Jesus died.

Meet Jesus.HB.16

The curtain in the temple tore in half.

Meet Jesus.HB.16

An officer said, 'This man was God.'

Fill in the missing words.

**Mark 15:24–39**

1. Jesus was nailed to a \_\_\_\_\_.
2. It was \_\_\_\_\_.
3. The sky was \_\_\_\_\_ for three hours.
4. Jesus \_\_\_\_\_, 'God, why have you left me?'
5. Jesus \_\_\_\_\_.
6. The curtain in the temple tore in \_\_\_\_\_.
7. An officer said, 'This man was \_\_\_\_\_.'