

DRC II Dual Recycling Compactor



*Increase Your
Return on the
Sales of Recycled
Materials*

*Two Compactors
in One*

*Neat and Attractive
Appearance*



The Flex-D-Vider® makes continuous or batch feed applications possible.

RAMJET
Stationary and self-contained compactors.



**Environmental
Solutions Group**

A DOVER COMPANY

Hospitals

Restaurants

Manufacturing Plants

Malls

Retail Stores

High-Rise Office Buildings

DRC II Dual Recycling Compactor

The DRC II is one dual-purpose compactor, occupying one space, with two separate compartments that enable you to compact a wide range of waste and recyclables all at one time.

Marathon's DRC II Offers Many Features and Benefits:

▼ **Increase Your Return**

Two separate compartments segregate waste and recyclables, which increases your return on the sale of recycled materials.

▼ **Two Compactors in One**

Separate, compact, and process two different materials, such as recyclables and garbage, at the same time in an area where space permits only one compactor.

▼ **Neat and Attractive Appearance**

Both recyclables and garbage are neatly contained after compaction, providing your building, facility, mall, or store with a neat and attractive appearance.



Compaction combinations are limitless with the DRC II:

- ▼ Garbage and Corrugated
- ▼ Corrugated and High-Grade Paper
- ▼ Paper and Aluminum Cans



The DRC II meets the challenge of state requirements for waste and recyclables at this high-rise office building where space is limited. The covered installation provides additional convenience for personnel.



At this large hospital, the DRC II averages 60% trash in one compartment and 40% cardboard in the other compartment. This provides convenience and flexibility with only one unit.



At this large urban department store, the DRC II averages a payload of 5 to 6 tons. Its lockable enclosed hopper, surrounded by a securely fenced loading area, increases employee security and confidence when depositing waste and recyclables for compaction.



Also available with an advanced system for measuring and reporting container usage and fullness. Users can input an I.D. number or insert a magnetic strip I.D. card to access the compactor.



The DRC II is also available with a Green Built® environmentally friendly 100% solar or solar-hybrid option.

A New Dimension in Recycling

Flex-D-Vider® Creates Two Variable-Capacity Compartments

The DRC II has a total capacity of 28 cubic yards (21 cubic meters). The two variable-capacity compartments are separated by a 24" (609,6mm) high solid welded barrier. This wall prevents liquid leaking from one side to the other. The DRC II accepts and compacts unequal and unpredictable volumes of two separate discardables. This is made possible by Marathon's Flex-D-Vider, a pivoting steel wall that adjusts the compartments' capacity during the loading and packing process. For easier discharge of the materials in the smaller compartment, a hydraulic cylinder enables the operator to move the Flex-D-Vider to the vertical center of the container, relieving the pressure on the remaining waste or recyclables. Each compartment when loaded can represent as little as 30% or as much as 70% of the unit's total volume. The DRC II can also be chute-fed to increase customer security and reduce labor costs.

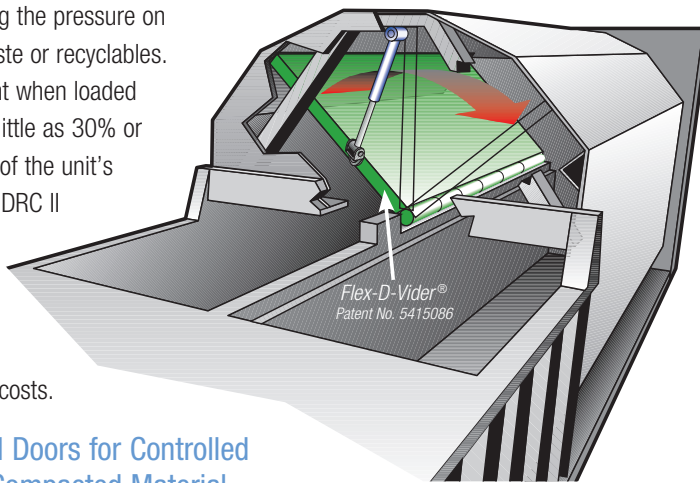

Four Individual Doors for Controlled Discharge of Compacted Material

Due to the many variable positions in which the Flex-D-Vider can be located, four individual doors are used for the discharge of materials.

- ✔ Upper doors are top hinged and have ratchet locks that enable the door to be opened independently of the lower doors.
- ✔ Lower doors are hinged in the center of the container. Each door is equipped with Marathon's standard ratchet latch and open independently for controlled discharge of compacted material.
- ✔ For wet waste applications, an optional door gasket is available with Marathon's custom designed P-shaped door seal, developed specially for self-contained compactors used for wet waste. Either or both sides may be gasketed.

Qwik Clean Tank®

The Qwik Clean Tank with exclusive Trash Check™ is a standard feature on the DRC II. It funnels any liquid seepage occurring during compaction into an enclosed area underneath the charge box floor. The liquid is automatically discharged at the disposal site, in effect flushing the container and the area behind the ram.

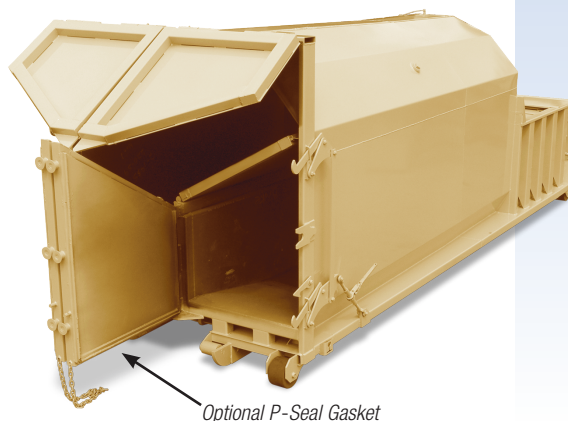

The Dual Recycling Compactor can be fitted with a variety of optional equipment such as through-the-wall security chutes and lockable doghouse hoppers. The DRC II is well suited for ground, doghouse, dock, or chute feed applications. Doghouses may be rear or side feed, or both (shown).



The DRC II features Marathon's CYCON Life-Xtender® Cyclic Control System

- ✔ Reliable, solid-state circuitry eliminates all pressure and limit switches.
- ✔ Extends wear life of cylinder and hoses — guaranteed by no-shock cycle control.
- ✔ Automatic "Container Full Assurance System" — ram dwells against the load at full pressure, resulting in better compaction.
- ✔ Smoother running, quieter operation.
- ✔ Advanced hydraulic design enables the system to operate at minimum pressure levels except when actually packing solid waste.
- ✔ Ensures more accurate "Advanced Warning" or "Container Full" options.
- ✔ Dramatically improves cold weather performance.

DRC II Dual Recycling Compactor

Dimensions and Specifications

Specifications:		
Charge Box Capacity		
Mfr. Rating (each side)	0.91 cy	0.70 m ³
Mfr. Rating (total)	1.82 cy	1.40 m ³
WASTEC Rating (total)	1.79 cy	1.37 m ³
Clear Top Opening	34½" x 48½"	876mm x 1219mm
Capacity per Hour (total)	165 cy	126 m ³
Performance Characteristics:		
Cycle Time	39 sec.	39 sec.
Total Normal Force	31,800 lbs.	141 kN
Normal Ram Face Pressure	18.7 psi	129 kPa
Ram Penetration	6½"	165mm
Electrical Equipment:		
Electrical Motor 3/60/230-480	10 HP	7.5 kW
Electrical Control Voltage	120 VAC	120 VAC
UL® Labeled Panel Box	Type NEMA 3R, All Circuits Fused	
Hydraulic Equipment:		
Hydraulic Pump Capacity	10 gpm	38 L/min.
Normal Pressure	2,000 psi	138 bar
Cylinder Bore	4½"	114mm
Cylinder Rod	2½"	64mm
Cylinder Stroke	55¼"	1403mm
Weight	16,000 lbs.	7258 kg

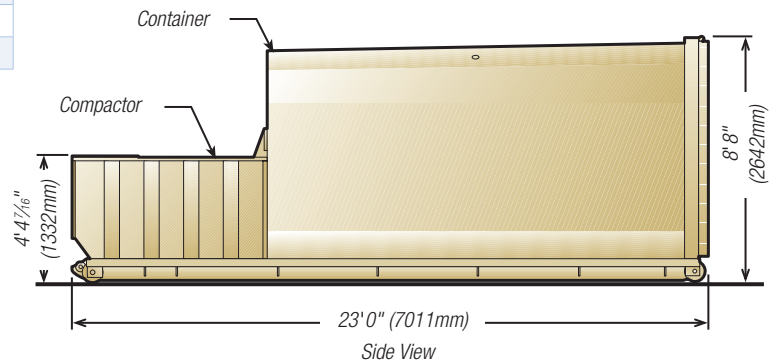
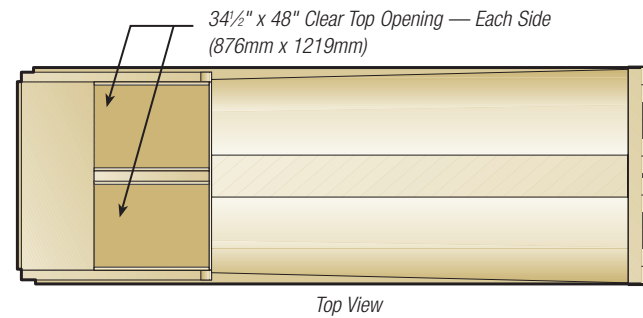
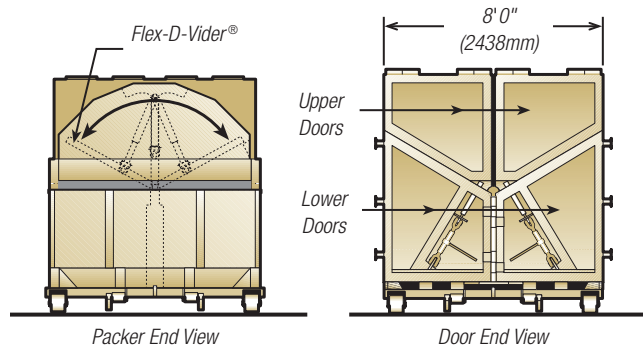

Also available as Green Built®, featuring solar and other environmentally friendly components.

Marathon's solar option is not UL and CUL Listed.



Stationary and self-contained compactors.

BIG STUFF

INC.
Waste Handling & Recycling Equipment
Trash, Linen and Temporary Debris Chutes

Sales • Service •
Installations • Rentals

301-499-3700

BIGSTUFFINC.COM

Marathon Equipment Company
P.O. Box 1798
Vernon, AL 35592-1798
800.633.8974
www.marathonequipment.com
NJPA Contract #060612-ESG

National Waste & Recycling Association
Collect. Recycle. Innovate.

ISRI
MEMBER

Environmental Solutions Group
A DOVER COMPANY
www.doveresg.com



Pictures in this literature are illustrative only. Specifications are subject to change without notice in order to accommodate improvements to the equipment. Complies with ANSI Regulation Z245.2, all OSHA standards, and certified under WASTEC's Stationary Compactor Certification Program. Products must be used with safe practice and in accordance with all applicable regulations and standards.