

Marathon CART DUMPERS



*For Plastic and
Steel Containers
from 90-96
Gallons to 4.0
Cubic Yards*

*Reliable
Performance
in Commercial
and Industrial
Applications*

*Heavy-Duty
Models Available*



RAMJET

Stationary and self-contained compactors.



**Environmental
Solutions Group**

A DOVER COMPANY

*Manufacturing
Facilities*

Malls

Large Hotels/Motels

Warehouses

Hospitals

Universities

Distribution Centers

The Smart, Cost-Effective Way to Compact

Marathon's Cart Dumpers can extend the benefits of compaction to all areas of your operation while minimizing equipment investments.

Marathon's standard Cart Dumpers are designed to handle 2- and 4-cubic-yard "trainable" steel containers or 1-cubic-yard plastic tilt carts.

Ground Level Dumpers

Ground Level Dumpers are used to dump containers at ground level into your stationary or self-contained compactor. They are ideal for park systems, shopping malls, and large or multi-building plants.

Marathon's Cart Dumpers are available in heavy-duty models that can handle gross loads up to 5,000 pounds.





Dock Level Dumpers

Dock Level Dumpers are used to dump containers that are rolled directly onto a stationary compactor from self-contained units next to a dock. They are ideal for industrial plants where waste accumulates in many locations. Standard units are powered by a separate 3-hp, 3-gpm power pack with on/off controls and a sustained manual pressure control. Heavy-duty units are powered by a 10-hp, 10-gpm power pack with electric controls. This enables the operator to effectively manage any stage of dumping.



Tilt Cart Dumpers

Tilt Cart Dumpers handle molded plastic tilt trucks. They are designed to hold the tilt truck during dumping without the need for mechanical locks.



Fork-Style Dumpers

Marathon's Cart Dumpers are available in standard or heavy-duty models. Heavy-duty cart dumpers are designed to handle gross loads up to 5,000 pounds.



In-Plant Trainable Containers

Marathon offers 2- and 4-cubic-yard capacity cart/containers ruggedly designed for in-plant use. Using a towing vehicle to "train" the carts from various locations throughout a facility to the dumper locations reduces labor to a fraction of that required to perform the same job manually. They come standard with 1,000-lb. capacity polyurethane-tired casters.



In-Plant Trainable Container options include: 1,600-lb. capacity polyurethane-tired casters; sleeves for interchangeable use with front loaders; tow bars for "trainable" containers (trains can be towed by forklift or similar unit).

DRY WASTE STATIONARY COMPACTION

In Action ...

Container is rolled into dumper arms. Marathon's 3- or 10-hp power pack is activated from outside the area of operation.

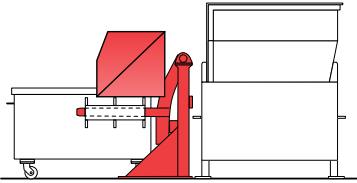

Special guards prevent spillage or leakage even in the vertical position. Operator has full control of cycle at all times.

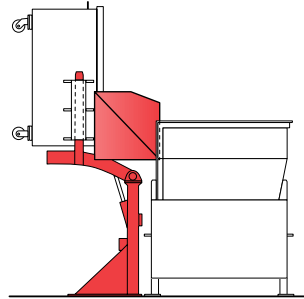

Container is tilted a full 45 degrees past vertical, assuring complete cleanout. Dumping cycle is 26 seconds for the heavy-duty and 36 seconds for standard models.

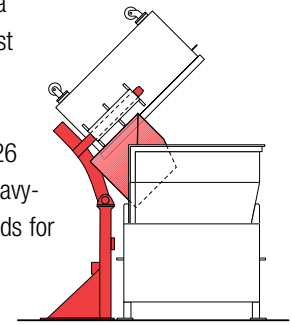

Specifications

	Standard	Heavy Duty
Cylinders (2):		
<i>Bore</i>	3" (76mm)	4½" (115mm)
<i>Rod</i>	1¼" (32mm)	2½" (64mm)
Stroke	16" (406mm)	25" (635mm)
Hydraulic Pressure	2,000 psi (13.8 MPa)	1,000 psi (6.9 MPa)
Hydraulic Pump Capacity	3 gpm (11.4 L/min.)	10 gpm (37.9 L/min.)
Motor Size	3 hp (2.2kW)	10 hp (7.5kW)
Controls	Manual	Electrical
Cycle Time	36 sec.	34 sec.
Weight Capacity	up to 2,500 lbs. (1,134 kg)	up to 5,000 lbs. (2,268 kg)
Tilt Cart Weight Capacity	up to 2,000 lbs. (907 kg)	up to 4500 lbs. (2,041 kg)

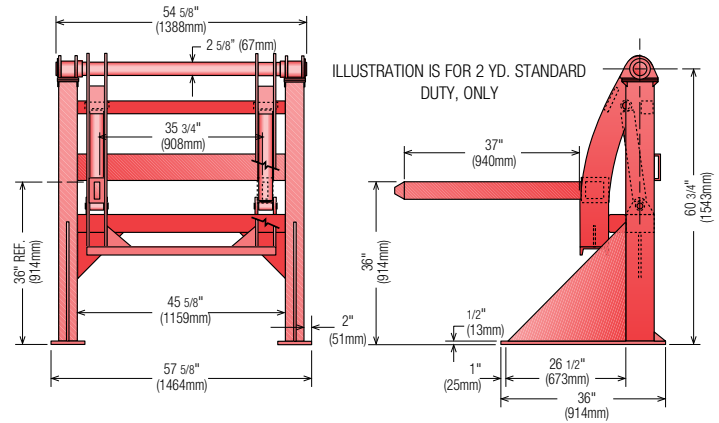

Custom-Engineered Dumpers

For applications with pre-existing or non-standard carts/containers, Marathon can design a custom dumper to meet your specifications and conform to applicable ANSI safety standards.



Other Marathon Dumpers

Integral Dumper for Self-Contained Compactors (RJ-250SC), Fork or Tilt Cart.

Cart Tipper for Stationary, Self-Contained, and Pak'ntainers Compactors to dump 90- and 96-gallon containers.



Marathon RJ-250 Compactor with Bayne Taskmaster Hi-Lift Lifter. For information on additional Bayne Lifters, contact your Marathon Sales Representative.



Marathon Equipment Company
P.O. Box 1798
Vernon, AL 35592-1798
800.633.8974
www.marathonequipment.com
NJPA Contract #060612-ESG



Environmental Solutions Group
A DOVER COMPANY

www.doveresg.com



Pictures in this literature are illustrative only. Specifications are subject to change without notice in order to accommodate improvements to the equipment. Complies with ANSI standard Z245.2, all applicable OSHA regulations, and certified under WASTEC's Stationary Compactor Certification Program. Products must be used with safe practice and in accordance with said regulations and standards.