

# Cat 328/335 DLCR Tunneling Boom

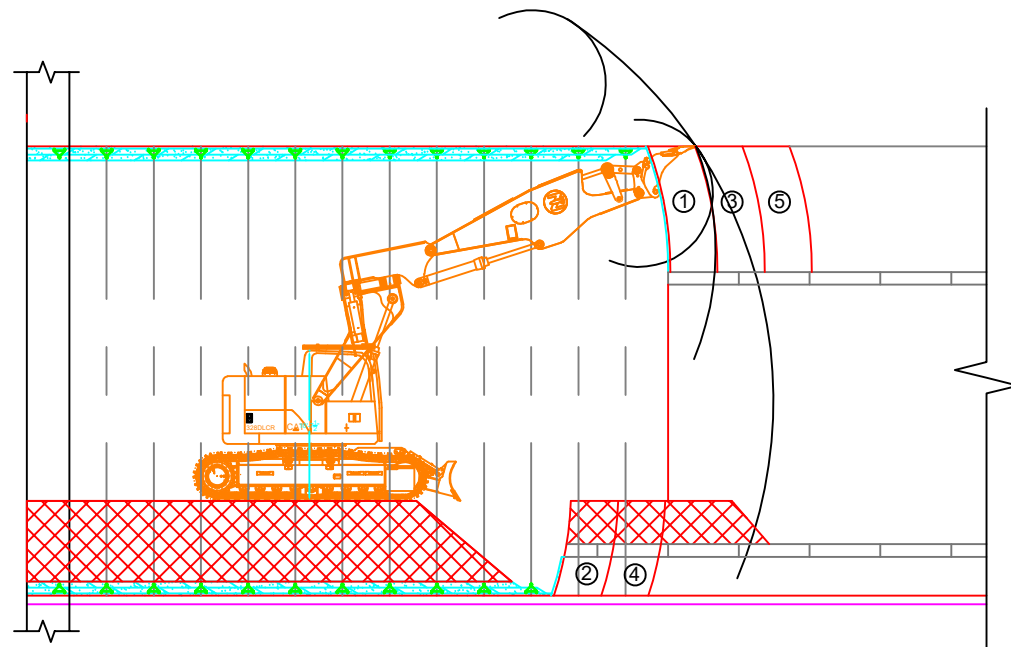

CAT 328 DLCR STANDARD TUNNELING BOOM  
SIDE DRIFT TOP HEADING

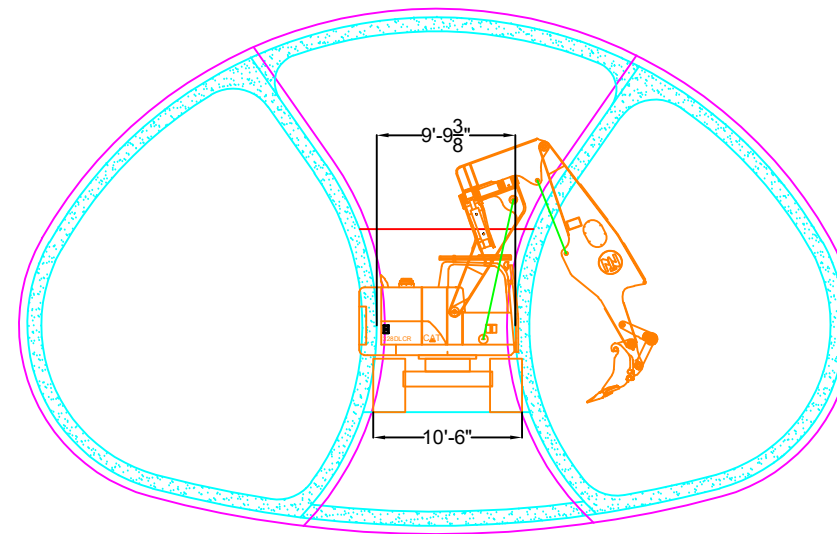

CAT 328 DLCR STANDARD TUNNELING BOOM  
CENTER DRIFT BENCH/INVERT

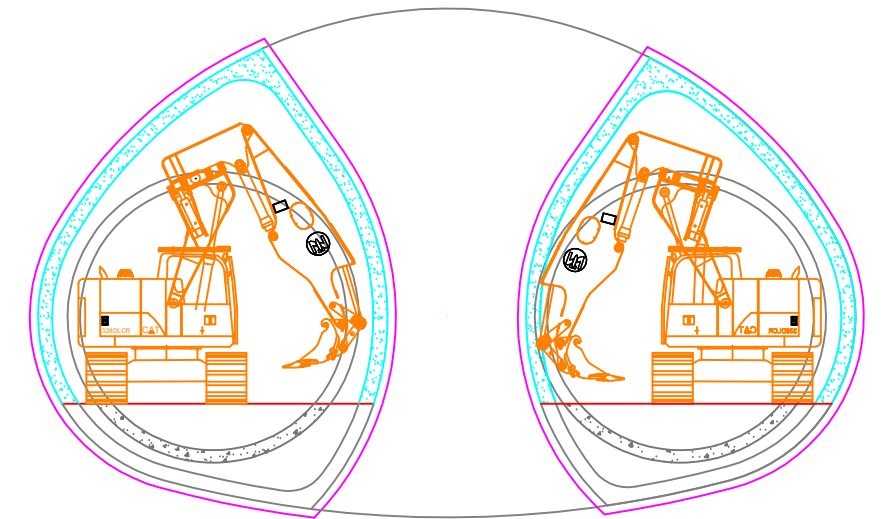

CAT 328 DLCR - STANDARD TUNNELING BOOM  
LEFT & RIGHT SIDE DRIFT  
(Track Width 11'-3")

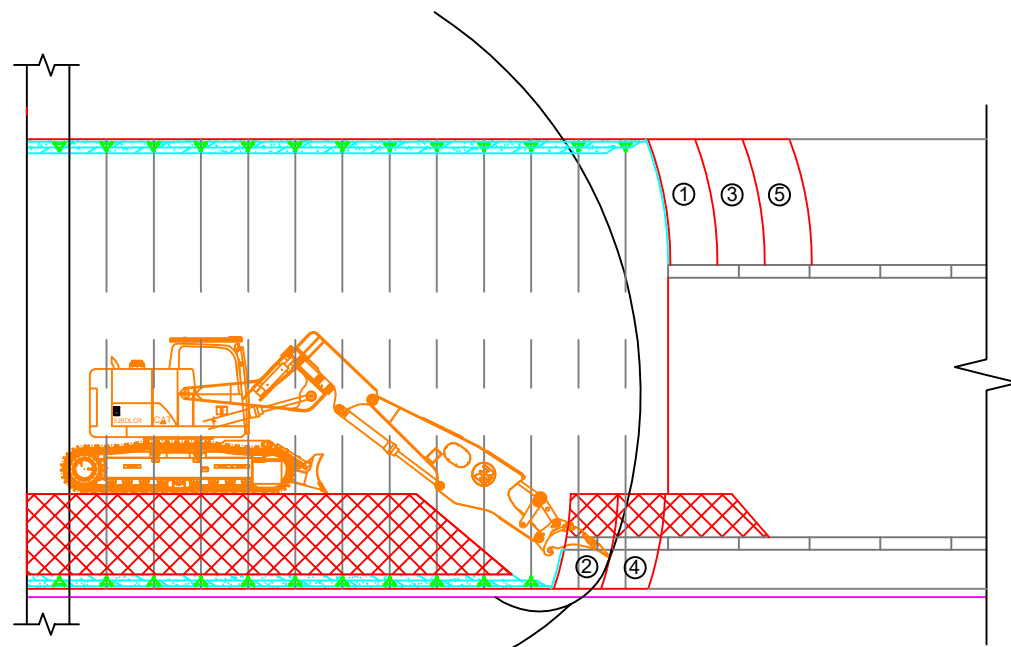

CAT 328 DLCR STANDARD TUNNELING BOOM  
SIDE DRIFT INVERT EXCAVATION

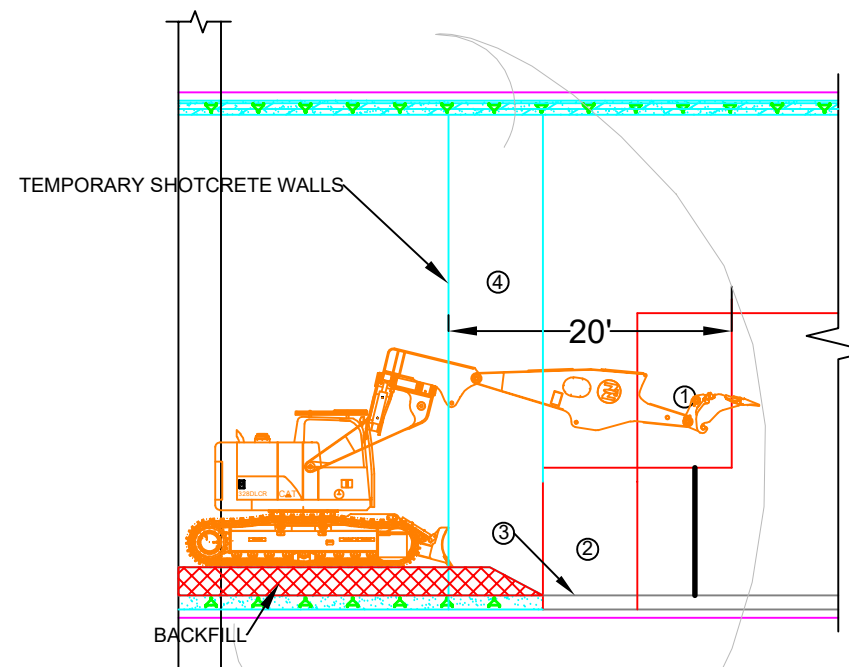

CAT 328 DLCR STANDARD TUNNELING BOOM  
CENTER DRIFT BENCH/INVERT

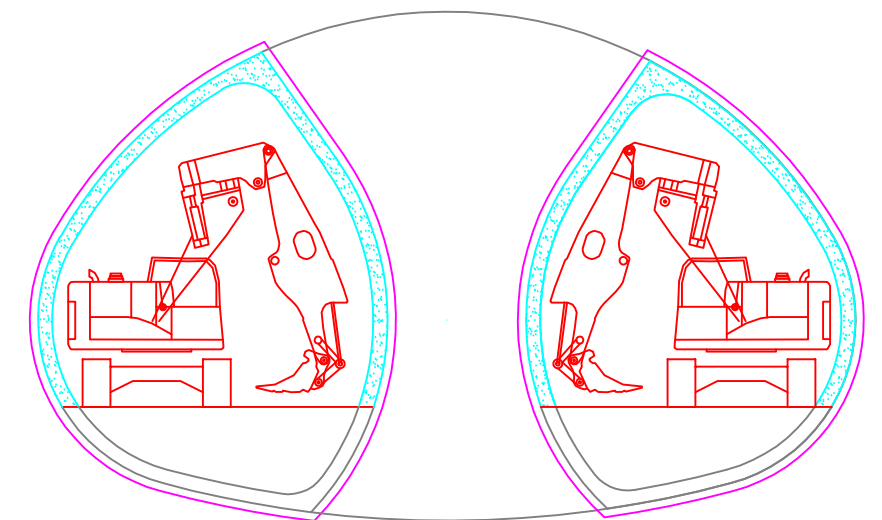

CAT 328 DLCR - STANDARD TUNNELING BOOM  
LEFT & RIGHT SIDE DRIFT  
(Track Width 10'-6")

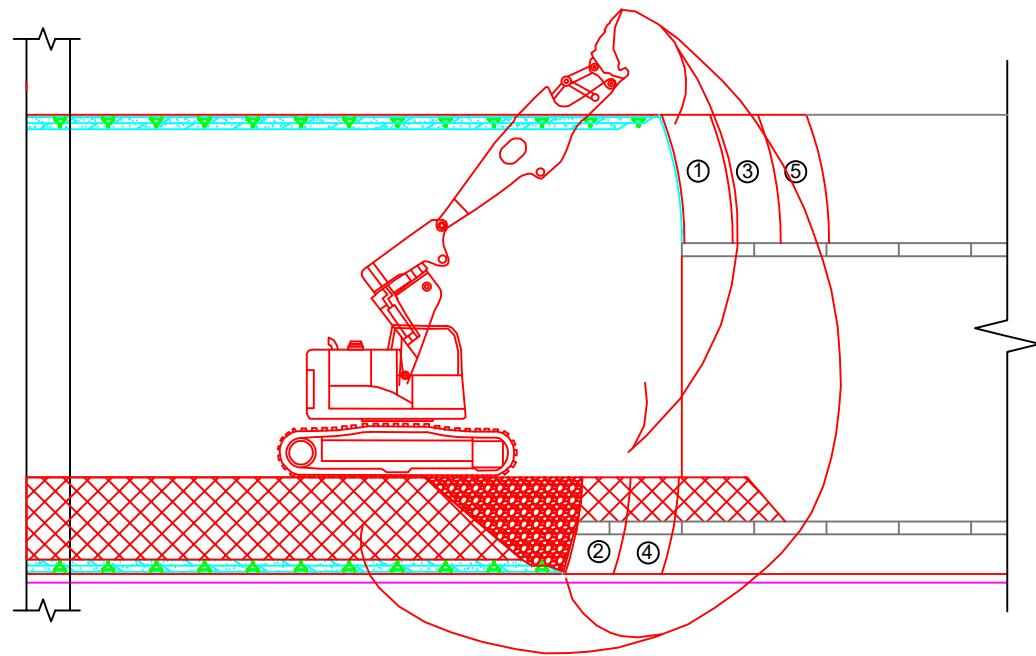

CAT 328 - SHORT TUNNELING BOOM  
SIDE DRIFT TOP HEADING

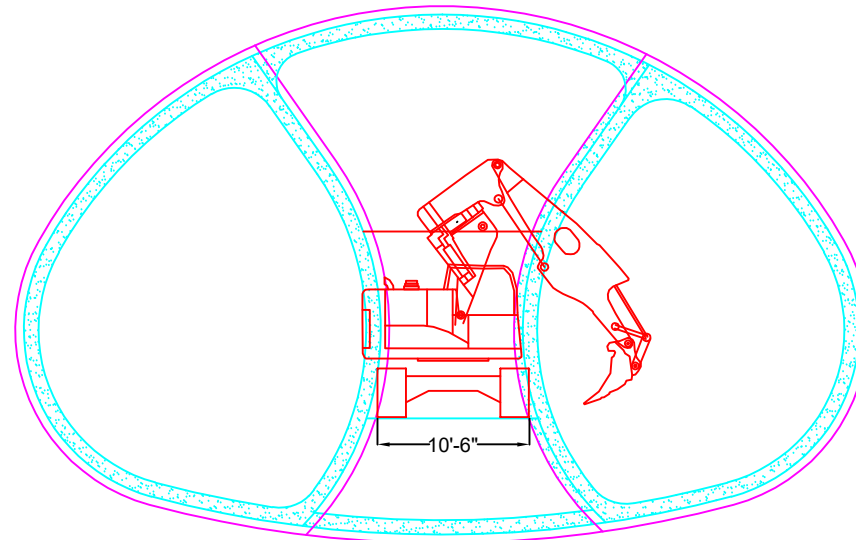

CAT 328 DLCR SHORT TUNNELING BOOM  
CENTER DRIFT BENCH/INVERT

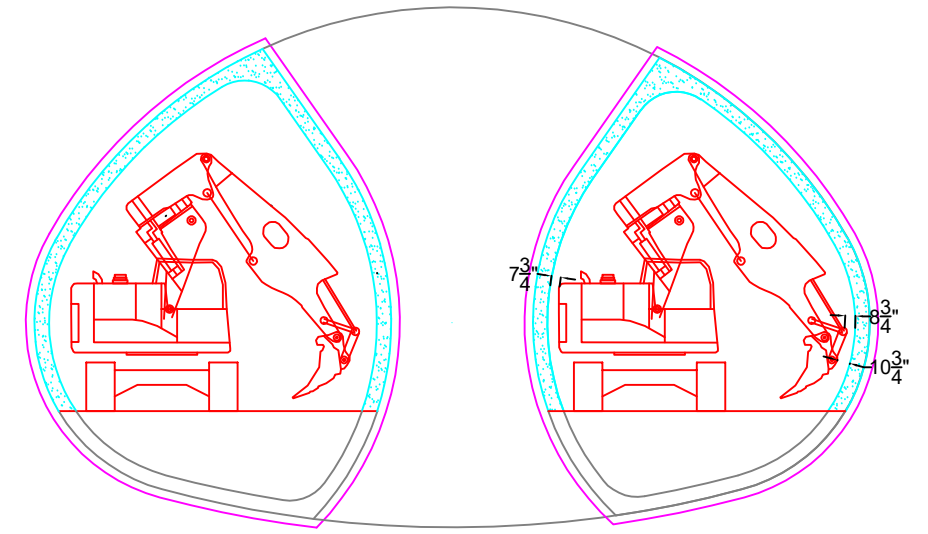

CAT 328 - SHORT TUNNELING BOOM  
LEFT & RIGHT SIDE DRIFT

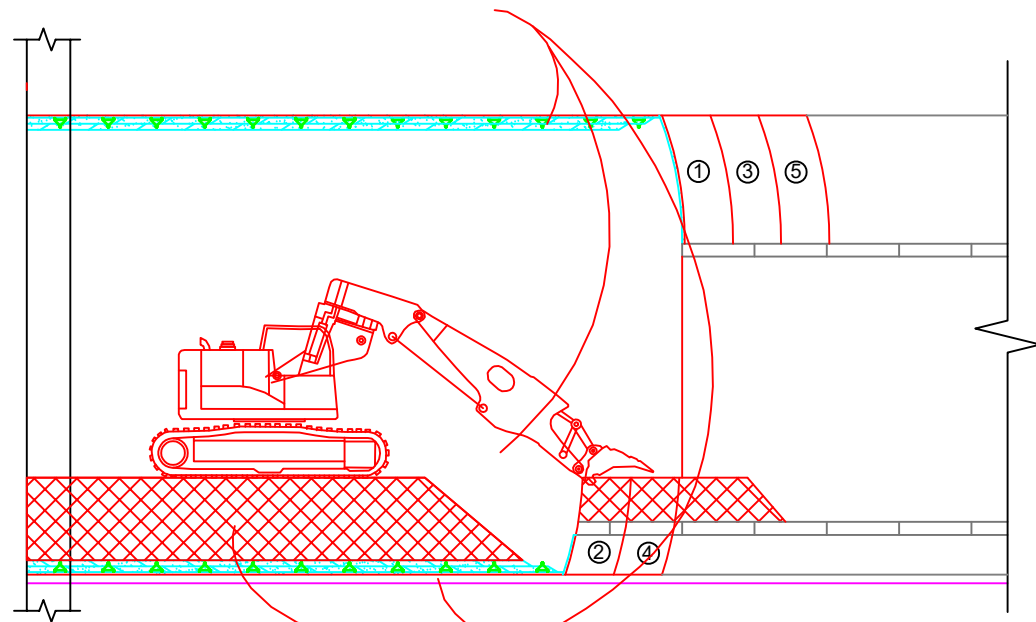

CAT 328 - SHORT TUNNELING BOOM  
SIDE DRIFT BOTTOM HEADING

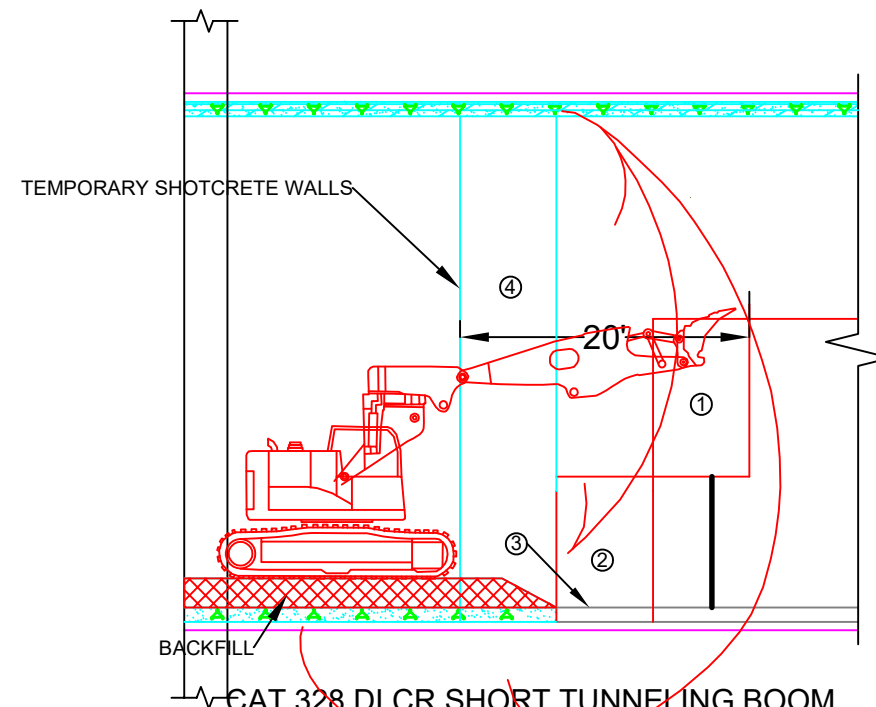

CAT 328 DLCR SHORT TUNNELING BOOM  
CENTER DRIFT BENCH/INVERT

# Zeppelin Tunnelling Excavator 328D LCR

## Technical Features

---

### Engine:

- Cat C7 engine with ACERT technology
- Net power 140 kW (190 PS) at 1.800 rpm (ISO 9249)
- Displacement 7.2l
- Fuel injection
- Turbocharger and Air-to-air Aftercooler
- Electric Starter with 24 V
- Prefilter, Air
- The Cart C7 engine meets Stage IIIA emission requirements

### Hydraulic:

- Two variable main pumps for outstanding performance
- Swing, travel and linkage with extra hydraulic pump
- Quick coupler hydraulic
- Two ways high pressure auxiliary hydraulic
- Medium pressure auxiliary hydraulic
- Joystick with thumbwheels for excellent work tool controllability
- Auxiliary hydraulic lines on boom and stick
- Pressure free return lines for milling cutter
- Hydraulic cylinder snubbers

### Upper structure:

- Sealed swivel
- Toolbox
- Maintenance free automatic swing parking brake
- Heavy duty bottom guard
- Hand rails
- Anti skid plates
- Counterweight 7,720 kg
- Tail swing radius 1,900 mm

### Undercarriage:

- Long Undercarriage, length 5,060 mm, width 3,190 mm
- X-Frame
- Track, 600 mm double grouser, grease lubricated
- Guard, track guiding, full length
- Guard, swivel
- Guard, travel motor HD
- Heavy duty track rollers

- Maximum travel speed max. 4,2 km/h
- Maximum drawbar pull 300 kN
- Hydraulic track adjuster
- Track deflectors (idlers/frame center)
- HD blade 3,190 mm

**Operating Weight:**

- 35,400 – 43,500 kg

**Operator**

**Environment:**

- Special tunnelling cab
- Tool selection for 10 pre programmed work tools (Tool Control)
- Monitoring panel with full graphic color display
- Seat, suspension, with high back and head rest
- Storage compartment
- Bolt-on falling object guarding system (FOGS) capability
- Seatbelt, 51mm, retractable
- Emergency exit (rear window, emergency hammer)
- Heater and defroster
- Travel control pedals with removable hand levers
- Converter, 5A-12V

**Other Standard Equipment:**

- Automatic engine speed control with one touch low idle
- Overload warning device
- Boom lowering control device
- Signal/warning Horn
- Working lights Boom, Cab and Frame mounted
- 3 Emergency stop devices
- Guard Falling Objects
- Fire extinguishing system “Fogmaker“
- Automatic lubrication
- SmartBoom
- Rear view camera
- Warning beacon
- Cold weather starting package
- CE certification

**Additionally tunneling equipment**

- 1 Ripper bucket with two tips
- Tunnel boom ZTAL4.650 + short boom (600mm shorter than standard)
- Mechanical fire suppression system type Fogmaker  
(3 triggers 1 x cabin inside, 1 x right side, 1 x left side)
- Rotating beacon light
- Central lubrication system
- Hammer- and shear hydraulic
- Pressure free return lines for milling cutter

**Service inspection**

Serialnumber	Working hours	Price FAS port Germany or Netherlands excl. VAT
<b>MKR00261</b>  <b>year built: 2014</b>		

**Delivery time**

**MKR00261 : approx. 4-6 weeks after order receipt to port Germany / Netherlands**

**Payment terms: payment before transport**





