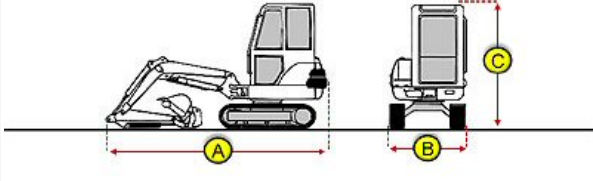

Inspection Report (Mini Excavator)

General Info

Year	2007
Make	CAT
Model	305C cr
Serial Number	HWJ02087
Hour Meter Reading	252Hrs.
Previous Application (e.g., earth moving, mining, demolition, etc)	General Construction

Dimensions

Measurement Guide	
A. Length (ft and inches)	17'6"
B. Width (ft and inches)	6'6"
C. Height (ft and inches)	8'3"
Operational Weight (lbs)	11,725lbs.



Features and Configuration

Control Station Type	Canopy
Bucket	Yes
Bucket Size (in inches)	12
Blade	Yes
Additional Attachment(s)	No
Hydraulic Coupler	No
Auxiliary Hydraulics	Yes
Hydraulic Thumb	No
Heat	No
A/C	No
Radio	No
Backup Camera	No
OMM (Operator & Maintenance Manual)	No
Telematics	No

Exterior Walkaround Photos

Inspection Report (Mini Excavator)

Exterior 360 Walkaround

Instructions	<p>Take photos of the exterior of the piece of equipment. Capture a full 360 degree walk around and all major components.</p> <p>Must have shots to capture:</p> <ul style="list-style-type: none"> - Front - 45 degree corner shot of left front - 45 degree corner shot of right front - Left side - Right side - Rear - 45 degree corner shot of left rear - 45 degree corner shot of right rear <p>Tips for good photos:</p> <ul style="list-style-type: none"> - Move the equipment into a open area without any visual distractions or other equipment in the background
Exterior Walkaround Photos	
	

Inspection Report (Mini Excavator)



Inspection Report (Mini Excavator)



General Appearance Inspection Points

General Appearance

Inspection Report (Mini Excavator)

Close-up Exterior Photos



Inspection Report (Mini Excavator)



Inspection Report (Mini Excavator)





Inspection Report (Mini Excavator)





Inspection Report (Mini Excavator)



Inspection Report (Mini Excavator)

	
	
	
Body Panels	3 - Normal Wear & Tear
Body Panel Condition	Some panel misalignment observed, Visible chipped paint or dents, Other (see comments)
Comments	Normal wear and tear

Inspection Report (Mini Excavator)

Body Panels Photos	
	
Doors / Canopy Latches	3 - Normal Wear & Tear
Doors / Canopy Latches Condition	No visible damage
Steps / Ladders	0
Handrails	3 - Normal Wear & Tear
Handrails Condition	Handrails are fully intact and appear structurally sound
Glass	0
Mirrors	3 - Normal Wear & Tear
Mirror Condition	Mirrors present and intact, no visible damage
Exterior Lights	0

Control Station Inspection Points

Control Station

Control Station	Take close-up photos of operator control station or cab including the floors, panels, headliner, seat, controls & displays, gauges & meters, and interior lights. Note any damage or wear.
-----------------	--

Inspection Report (Mini Excavator)

Serial Number Plate Photo



Operator Cabin Photos



Inspection Report (Mini Excavator)





Inspection Report (Mini Excavator)





Inspection Report (Mini Excavator)

	
	
	
Operator Cabin Overall	3 - Normal Wear & Tear
Operator Cabin Overall Condition	Good cabin appearance, solid floors, panels, and ceiling, Minor cosmetic wear to cabin surfaces, floors, panels, and ceiling
Operator Seat	3 - Normal Wear & Tear
Operator Seat Condition	Seat(s) in good condition, no stains or tears in upholstery, Seat(s) have minor surface staining or small tears
Cabin Lights	0
Safety Lock Out / Stop	3 - Normal Wear & Tear

Inspection Report (Mini Excavator)

Safety Lock Out / Stop Condition	Safety lock out device is present, in good condition, and functional
Controls & Switches	3 - Normal Wear & Tear
Controls & Switches Condition	All switches are installed and functional, Switches have good functionality, minor cosmetic damage observed, Other (see comments)
Comments	Switch decals worn
Controls & Switches Photos	
	
	
Hour Meter Activity	3 - Normal Wear & Tear
Hour Meter Condition	Hour meter is functional and in good condition

Inspection Report (Mini Excavator)

Hour Meter Activity Photos		
Other Gauge Activity	3 - Normal Wear & Tear	
Other Gauge Condition	All cockpit gauges are functional and in good condition	
Other Gauge Activity Photos		
Other Gauge Activity Photos		
Heater & A/C	0	
Travel Alarm	3 - Normal Wear & Tear	
Travel Alarm Condition	Travel alarm is installed and functioning as expected	
Horn	3 - Normal Wear & Tear	
Horn Condition	Horn is installed and functioning as expected	

Inspection Report (Mini Excavator)

Backup Camera	0
---------------	---

Engine Inspection Points

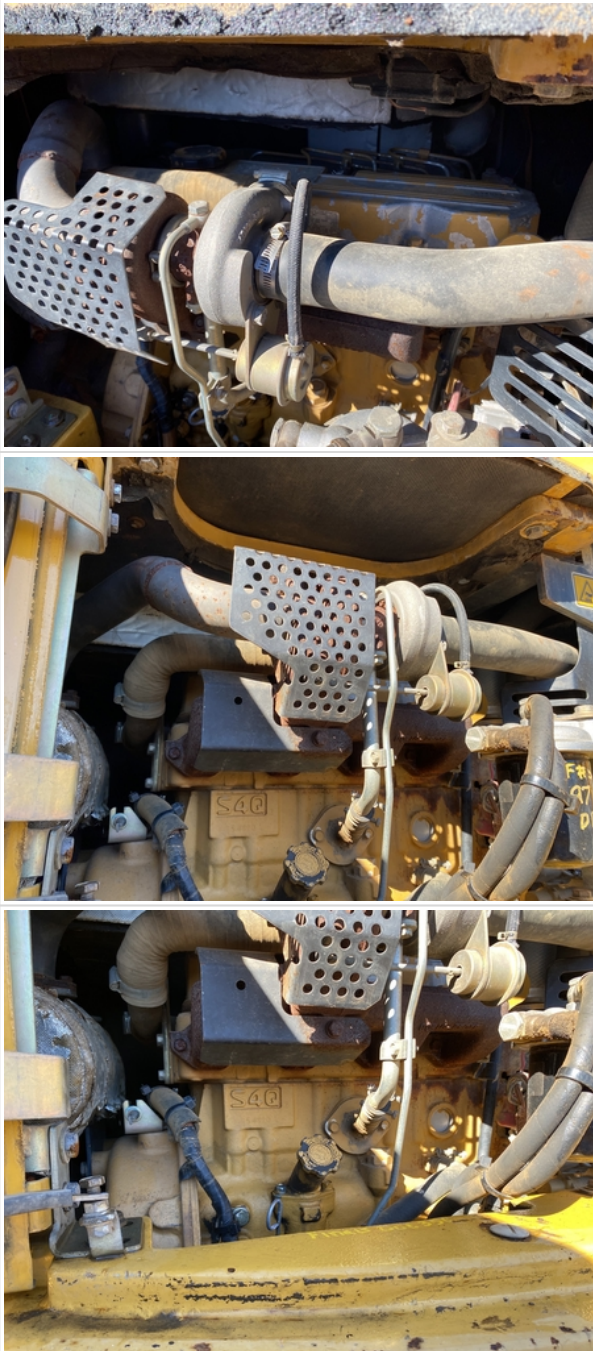

Engine

Engine Type (Make, Model, Cylinders, Hp)	Mitsubishi - 49HP - 2.5L - 4Cyl.
Emissions Tier	Tier 3
Engine Serial Number	N/A
Engine Fuel Type	Diesel
Engine Photos	

Inspection Report (Mini Excavator)





Inspection Report (Mini Excavator)

	
	
	
Blow-by (Visual Observation Check)	Yes
Comments	Blowby seen at breather hose
Unusual Noises (Upon Start-up, Idle, Shutdown)	No
Unusual Noise Notes	No unusual noises heard, Other (see comments)
Comments	Minor rattle sound at turbo heat shield (loose hardware, nothing major)
Engine Smoke (Upon Start-up, Idle, Shutdown)	Yes

Inspection Report (Mini Excavator)

Engine Smoke Notes	Engine smoke observed upon start up, Other (see comments)
Comments	Small amount of engine smoke seen ONLY at startup
Engine Exhaust Color	Clear
Battery	3 - Normal Wear & Tear
Battery Condition	Clean & dry appearance, tight connections, Other (see comments)
Comments	Battery stamped 2/2021
Battery Condition Photos	
Radiator	3 - Normal Wear & Tear
Radiator Condition	Radiator fins & components appear to be in good working order, no signs of damage or leaks

Inspection Report (Mini Excavator)

Radiator Photos	
	
Belts	3 - Normal Wear & Tear
Belt Condition	Belts appear in good condition & alignment with proper tension
Hoses	3 - Normal Wear & Tear
Hose Condition	Firm, pliant hoses with no signs of wear or leaks
Water Pump	3 - Normal Wear & Tear
Water Pump Condition	No unusual pump noises heard
Cooling System Leaks	No
Coolant Color / Appearance	3 - Normal Wear & Tear
Coolant Color/Appearance Notes	Normal Translucent appearance, no visual signs of contamination
Oil Leaks	Yes
Oil Leak Notes	No oil leaks seen, Dried oil seepages seen
Comments	Minor oil seepage buildup seen at front of engine cover (no active leaks seen)

Inspection Report (Mini Excavator)



Oil Leak Photos	
Oil Color / Appearance	3 - Normal Wear & Tear
Oil Color / Appearance Notes	Appropriate oil level, Other (see comments)
Comments	Engine service recommended
Fuel Leaks	No
Equipped with DPF (Diesel Particulate Filter)	No
Requires DEF (Diesel Exhaust Fluid)	No
Overall Engine Appearance	Clean & dry
Overall Engine Comments	Overall, engine well maintained with. I major problems observed.

Drivetrain Inspection Points

Drivetrain

Drivetrain	Take close-up photos of the drivetrain components including transmission housing, drive shaft, drive motors, fittings, and hoses. Note any damage or wear.
Drivetrain Photos	



Inspection Report (Mini Excavator)

		
		
Hydrostatic Transmission?	Yes	
2 Speed?	Yes	
Hydrostatic Drive Configuration	Split Transmission	
Drive Motors	2 - Above Average Wear	
Drive Motor Photos		

Inspection Report (Mini Excavator)

		
Hydrostatic Parking Brake	3 - Normal Wear & Tear	
Hydrostatic Parking Brake Condition	Good brake function	
Overall Drivetrain Comments	Overall drivetrain in good shape and functioning normal.	



Chassis Inspection Points

Boom Condition	3 - Normal Wear & Tear	
Boom Photos		
		

Inspection Report (Mini Excavator)

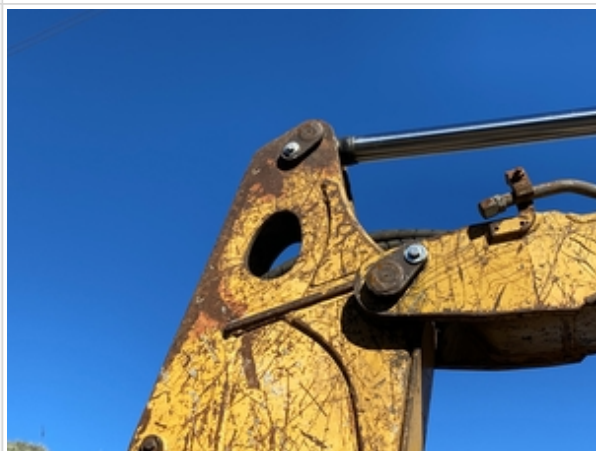

Inspection Report (Mini Excavator)

	
	
<p>Stick Condition</p>	<p>3 - Normal Wear & Tear</p>
<p>Stick Photos</p>	



Inspection Report (Mini Excavator)



Inspection Report (Mini Excavator)





Inspection Report (Mini Excavator)

		
		
<p>Boom Base Pin & Bushings</p>	<p>3 - Normal Wear & Tear</p>	
<p>Boom Base Pin & Bushings Photos</p>		

Inspection Report (Mini Excavator)



Inspection Report (Mini Excavator)

		
		
Boom to Stick Pin & Bushings	3 - Normal Wear & Tear	
Stick to Bucket Pin & Bushings	3 - Normal Wear & Tear	
Comments	Minor play in stick to bucket linkage pins	
Stick to Bucket Pin & Bushings Photos		



Inspection Report (Mini Excavator)





Turntable Bearing

3 - Normal Wear & Tear

Inspection Report (Mini Excavator)

<p>Turntable Bearing Photos</p>		
		
<p>Bottom Covers</p>	<p>3 - Normal Wear & Tear</p>	
<p>Bottom Covers Photos</p>		

Inspection Report (Mini Excavator)

		
		
Overall Chassis	3 - Normal Wear & Tear	
Overall Chassis Comments	Overall chassis in solid condition with no issues observed.	

Undercarriage Inspection Points

Rubber Track Undercarriage

Roller Frames	3 - Normal Wear & Tear	
Roller Frames Photos		

Inspection Report (Mini Excavator)



Inspection Report (Mini Excavator)



Track Belt

3 - Normal Wear & Tear

Inspection Report (Mini Excavator)

Track Belt Photos



Inspection Report (Mini Excavator)



Rubber Belt Drive Lugs



3 - Normal Wear & Tear

Inspection Report (Mini Excavator)



Rubber Belt Drive Lugs Photos



Inspection Report (Mini Excavator)

		
Track Tensioners	3 - Normal Wear & Tear	
Front Idlers	3 - Normal Wear & Tear	
Front Idlers Photos		
		

Inspection Report (Mini Excavator)



	
	
	
Rear Idlers	0
Track Rollers	3 - Normal Wear & Tear

Inspection Report (Mini Excavator)

Track Rollers Photos



Inspection Report (Mini Excavator)

		
Sprockets	3 - Normal Wear & Tear	
Sprockets Photos		
		

Hydraulics Overall Inspection Points

Hydraulics Overall



Hydraulic System	Take close-up photos of the hydraulic components including the pump, lines, fittings, controls, and levers. Note any damage, wear, or leaks.
-------------------------	--

Inspection Report (Mini Excavator)

Hydraulic System Photos





Inspection Report (Mini Excavator)

		
Wet or Damp Hydraulic Lines / Fittings	No	
Appearance of Hydraulic Lines / Fittings	3 - Normal Wear & Tear	
Hydraulic Lines / Fittings Condition	Hydraulic lines & fittings are clean and in good condition	
Appearance of Hydraulic Lines / Fittings Photos		
		



Inspection Report (Mini Excavator)



Inspection Report (Mini Excavator)

	
	
	
Unusual Noises (Hydraulic Pump)	No
Hydraulic Pump Notes	No unusual noises heard during operation
External Controls / Levers	3 - Normal Wear & Tear
External Controls / Levers Condition	Good function & condition of hydraulic controls

Inspection Report (Mini Excavator)

External Controls / Levers Photos		
		
		

Hydraulics Cylinders Inspection Points



Boom Cylinder: Mounting Pin	3 - Normal Wear & Tear
Boom Cylinder: Oil Leaks	No

Inspection Report (Mini Excavator)



Boom Cylinder Photos





Inspection Report (Mini Excavator)

		
Stick Cylinder: Mounting Pin	3 - Normal Wear & Tear	
Stick Cylinder: Oil Leaks	No	
Stick Cylinder Photos		
		

Inspection Report (Mini Excavator)

		
Bucket Cylinder: Mounting Pin	3 - Normal Wear & Tear	
Bucket Cylinder: Oil Leaks	No	
Bucket Cylinder Photos		
		

Inspection Report (Mini Excavator)

		
<p>Blade</p>	<p>3 - Normal Wear & Tear</p>	
<p>Blade Photos</p>		
		

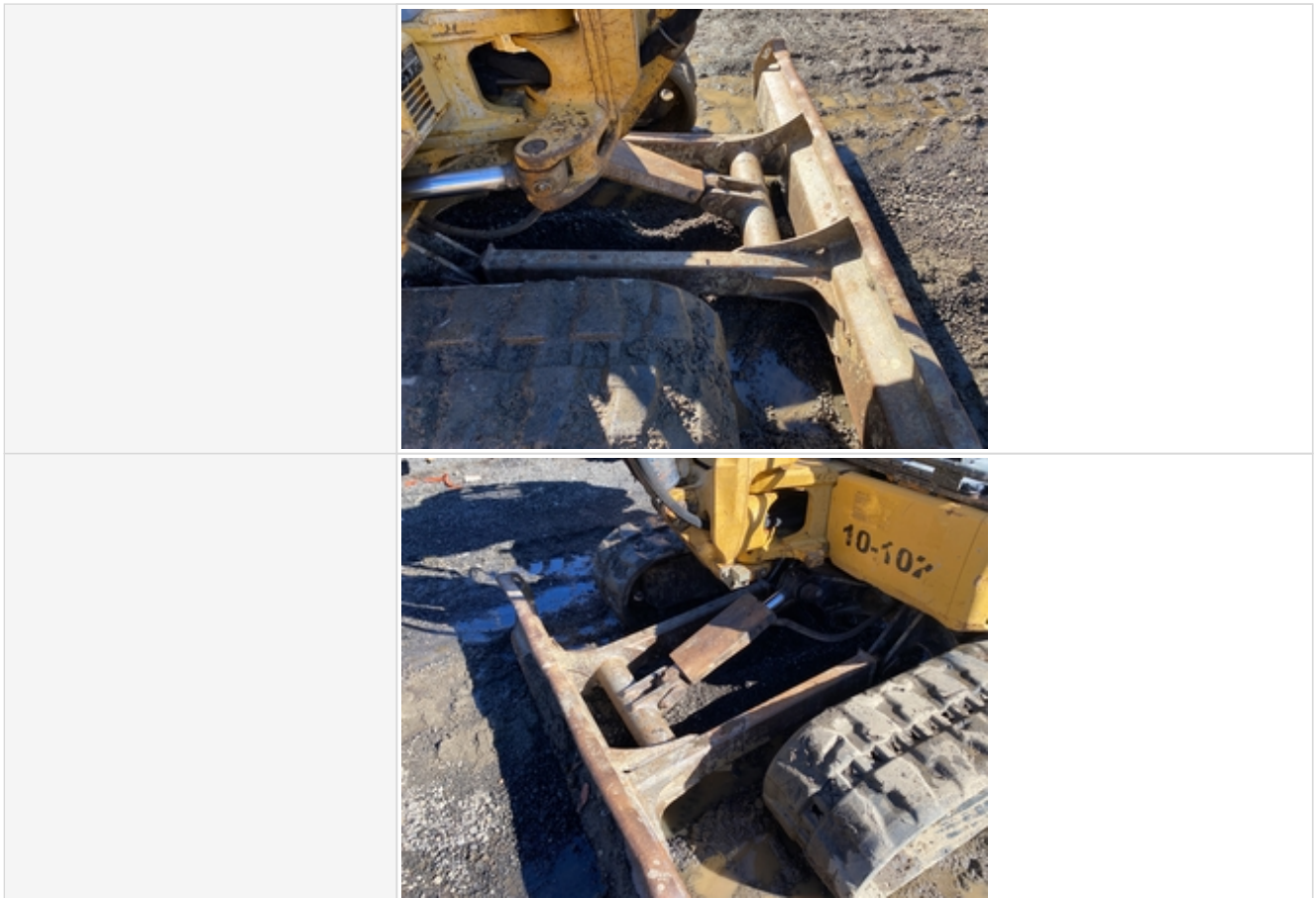

Inspection Report (Mini Excavator)



Bucket Inspection Points

<p>Bucket Condition</p>	<p>3 - Normal Wear & Tear</p>
<p>Bucket Photos</p>	



Inspection Report (Mini Excavator)

		
		
		
Bucket Hose & Fittings	3 - Normal Wear & Tear	

Blade Inspection Points

Blade Condition	3 - Normal Wear & Tear	
Blade Edge	3 - Normal Wear & Tear	
Blade Hose & Fittings	3 - Normal Wear & Tear	
Blade Cylinder	3 - Normal Wear & Tear	

Inspection Report (Mini Excavator)

Blade Cylinder Photos		
		

Functional Test

Forward & Reverse	3 - Normal, Operating as Expected
Swing Table Rotation	3 - Normal, Operating as Expected
Boom Lift / Angle / Tilt	3 - Normal, Operating as Expected
Blade Functionality	3 - Normal, Operating as Expected
Overall Functional Test Comments	Overall machine functions great from the hydraulics to the powertrain.
Operating Video	Click to Download

Overall Assessment

Overall Assessment	
Exterior Rating	3 - Normal Wear & Tear
Interior Rating	3 - Normal Wear & Tear
Safety Rating	3 - Normal Wear & Tear
Quality Rating	3 - Normal Wear & Tear
Functionality Rating	3 - Normal, Operating as Expected
Overall Rating	3 - Normal Wear & Tear



Inspection Report (Mini Excavator)

What's Great About the Machine	Machine has very low hours and has been well maintained. All implements tight and powertrain runs well. Undercarriage has plenty of life left and no leaks observed.
What Needs Work	Cosmetic damages all the way around. Top of blade has been slightly dented. Engine could use a service.
Date/Time	01-06-2023