

# K-SERIES LOADERS

## 624K/644K/724K

139–197 kW (186–264 net hp)



**JOHN DEERE**



# Job driven. Customer inspired. And a fuel-sipping hybrid-electric model.

Secured keyless start. Advanced onboard diagnostics. Innovative Quad-Cool™ system with cool-on-demand swing-out fan. These and the many other features found in our K-Series come from listening to customer needs and responding with exceptionally productive, durable, and versatile loaders. Among the big customer inspirations is the availability of the hybrid-electric drivetrain in the 644K. Check out the whole K Loader line today. And be prepared to be an inspired customer yourself.

| Key Specifications   | 624K                             | 644K  | 724K                                      |
|--|----------------------------------|---|---|
| <b>Net Peak Power</b>                                      | 139 kW (186 hp)                  | 173 kW (232 hp) /<br>171 kW (229 hp) Hybrid | 197 kW (264 hp)                           |
| <b>Bucket Capacity</b>                                     | 2.7 m <sup>3</sup> (3.5 cu. yd.) | 3.1–3.2 m <sup>3</sup> (4.0–4.25 cu. yd.)   | 3.1–3.6 m <sup>3</sup> (4.0–4.75 cu. yd.) |
| <b>Z-Bar:</b>  |                                  |   |   |
| <b>Tipping Load, 40-deg. Full Turn, No Tire Deflection</b> | 12 006 kg (26,469 lb.)           | 12 798 kg (28,214 lb.)                      | 14 266 kg (31,451 lb.)                    |
| <b>Breakout Force</b>                                      | 12 821 kg (28,266 lb.)           | 15 378 kg (33,903 lb.)                      | 15 607 kg (34,408 lb.)                    |
| <b>Operating Weight</b>                                    | 15 747 kg (34,717 lb.)           | 18 682 kg (41,188 lb.)                      | 19 419 kg (42,812 lb.)                    |
| <b>Powerllel™:</b>   |                                  |   |   |
| <b>Tipping Load, 40-deg. Full Turn, No Tire Deflection</b> | 9312 kg (20,530 lb.)             | 12 923 kg (28,489 lb.)                      | N/A                                       |
| <b>Breakout Force</b>                                      | 10 759 kg (23,719 lb.)           | 12 029 kg (26,519 lb.)                      | N/A                                       |
| <b>Operating Weight</b>                                    | 17 167 kg (37,847 lb.)           | 20 269 kg (44,685 lb.)                      | N/A                                       |
| <b>Tool Carrier:</b>                                       |                                  |   |   |
| <b>Tipping Load, 40-deg. Full Turn, No Tire Deflection</b> | 10 253 kg (22,605 lb.)           | N/A   | N/A                                       |
| <b>Breakout Force</b>                                      | 10 978 kg (24,202 lb.)           | N/A   | N/A                                       |
| <b>Operating Weight</b>                                    | 16 166 kg (35,640 lb.)           | N/A   | N/A                                       |

Fluid-efficient John Deere PowerTech™ EPA Final Tier 4 (FT4)/EU Stage IV diesels provide generous displacement, power, and lugging ability.

644K Hybrid provides fuel efficiency via a PowerTech EPA Interim Tier 4 (IT4)/EU Stage IIIB engine coupled with an ultra-smooth PowerShift™ hybrid-electric transmission system.

PowerTech diesels maintain impressive torque reserves for great boom and bucket speeds in and out of the pile, delivering heaped loads — even in wet- or hard-packed material.

K-Series Loaders ride on a wide stance that provides additional lateral stability for handling heavy loads and working on rough terrain. Overall balance is exceptional.

John Deere WorkSight™ is an exclusive suite of telematic solutions that increases uptime while lowering operating costs. At its heart, JDLINK™ Ultimate machine monitoring provides real-time utilization data and alerts to help you maximize productivity and efficiency while minimizing downtime. Remote diagnostics enable your dealer to read codes, record performance data, and even update software without a trip to the jobsite.





# Hard work made simple.

What operator wouldn't be more productive in the high-back air-ride seat of a K-Series Loader? Up front, an enhanced multifunction monitor displays operating, diagnostic, and maintenance info on a color LCD screen with easy-on-the-eyes clarity. Generous tinted glass and a low-profile console allow a commanding view of the work. Spacious and quiet cab boasts seat-mounted controls, fatigue-beating ergonomics, and plenty of limb-stretching legroom. And their sealed-switch modules with keyless start and push-button operation of other machine functions help you work harder with less effort.



To help prevent unauthorized machine operation, the keyless-start security system requires a numeric pass code when activated.

Available premium heated air-ride arm-chair seat adjusts multiple ways for extra comfort and cushioning.

Standard eight-amp converter (15 and 30 amp are optional) and a 12-volt outlet provide convenient power for cell phones and other electronic devices.

Brake and throttle pedals are conveniently positioned, allowing plenty of legroom and easy entrance and exit.

Adjustable automotive-style louvers provide effective airflow to keep the glass clear and pressurized cab comfortable.

1. Multi-language color LCD monitor provides push-button access to a wealth of machine data and functions:

**Vital information**, including transmission mode, gear, engine rpm, and ground speed.

**Enhanced onboard diagnostics** with speed, pressure, temperature readings, and switch status.

**Customized machine settings** — Quick Shift, Auto-to-1st, and ride control match your operating characteristics to specific jobs and conditions.

**Optional embedded payload scale** weighs each bucket load, helping fill trucks to the max.

2. Optional joystick steering on the 644K and 724K is ideal for V-pattern truck loading. It adapts to the loader's ground speed to deliver smooth control for load-and-carry applications.

3. Optional rearview camera only or optional rearview camera and radar object-detection system provides maximum visibility via an LCD screen. Radar object-detection system includes an audible alert for extra awareness in tight quarters and high-traffic areas.

4. Spacious cab with a cooler compartment and beverage holder provides plenty of room to stow your stuff.

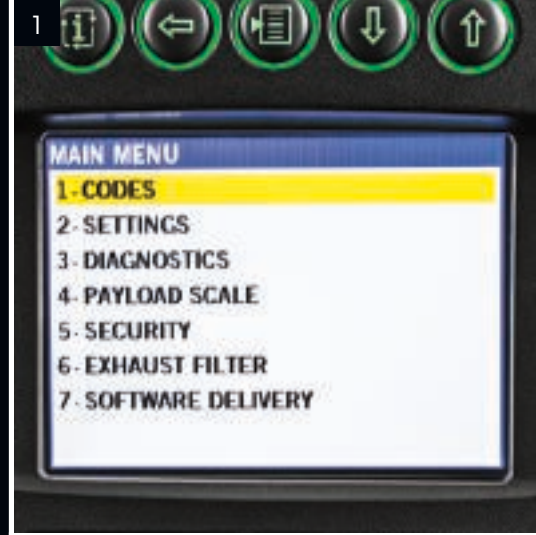

# More power and control mean more productivity.

If you've got maximum productivity in mind, put a K-Series Loader at the top of your list. It's not just big torque reserves that make them such impressive performers. Single-lever joystick or two-lever fingertip controls provide smooth, near-effortless control. Excavator-style hydraulics sense the load to better deliver the flow needed for combined functions and fast work cycles. And you won't find a smoother-shifting loader — the standard PowerShift transmission with Smart-Shift™ technology continuously evaluates speed and load conditions, and adjusts clutch-pack engagement to suit.



1. A backlit touchpad sealed-switch module controls keyless start and 24 other machine functions, allowing the operator to activate boom-height kickout, return to carry, and return to dig from the seat.

2. Choose between a single-lever joystick or...

3. ...two-lever fingertip pilot-operated hydraulic controls.



Standard five-speed transmission with lockup torque converter for gears 2–5 increases acceleration, speeds cycles, and optimizes power and fuel efficiency during transport, roading, and ramp climbing.

The 644K Hybrid teams a purpose-built three-speed hybrid-electric transmission with an IT4 PowerTech engine to squeeze the most out of every drop of fuel.

Even when working with large wet loads, K-Series Loaders maintain excellent boom and bucket power into and out of the pile.

Optional wheel-spin control boosts productivity by improving traction in troublesome underfoot conditions, reducing tire wear, fuel costs, and operator fatigue.

Powerl1el-equipped 624K and 644K Loaders have two presets for added convenience when frequent attachment changeover is required.

Joystick F-N-R selector provides convenient direction and full-range gear changes, and includes an innovative Quick-Shift feature for push-button gear changes.

Boom-height kickout and return-to-carry functions speed production in repetitive loading applications.

Brake-pedal-activated clutch cutoff increases productivity and boom-cycle speed by maintaining engine speed while the transmission is disengaged. It's programmable to match the slope of your dumpsite — level, small, or steep.

Responsive steering and full 80-deg. articulation increase maneuverability in tight quarters, delivering faster cycle times with fewer three-point turns.





# Parallel lift that's simply unparalleled.

The 624K and 644K Powerllec Loaders deliver both powerful digging forces and parallel lift. Their innovative design allows load forces to work with, not against, the boom for big breakout forces — even in difficult digging. Impressive torque throughout the entire dump and rollback range enables these Powerllec loaders to excel at a wide variety of material-handling tasks. But don't just look for these John Deere advantages in the numbers on a spec sheet. The best way to fully appreciate them is on your jobsite. Whatever the task, whatever the load, you'll discover parallel lift that's without parallel.



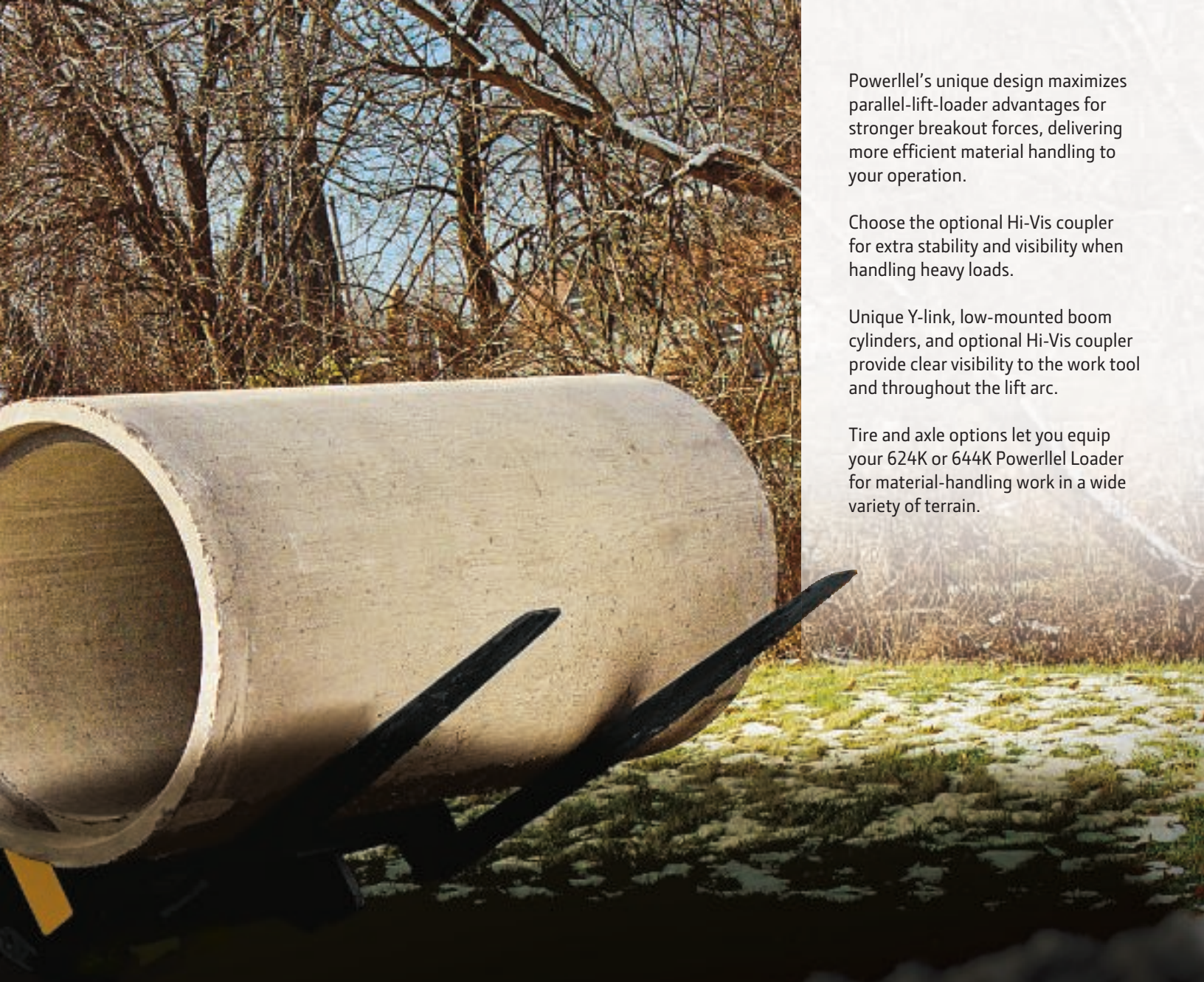

Powerllel's unique design maximizes parallel-lift-loader advantages for stronger breakout forces, delivering more efficient material handling to your operation.

Choose the optional Hi-Vis coupler for extra stability and visibility when handling heavy loads.

Unique Y-link, low-mounted boom cylinders, and optional Hi-Vis coupler provide clear visibility to the work tool and throughout the lift arc.

Tire and axle options let you equip your 624K or 644K Powerllel Loader for material-handling work in a wide variety of terrain.

1. If it's a traditional tool carrier you want, opt for a 624K Tool Carrier with parallel-lift boom. Its linkage automatically levels the load throughout the lift cycle and provides unrestricted visibility to the coupler.

2. The 624K and 644K Powerllel Loaders deliver outstanding breakout forces throughout the entire bucket and angle range to conquer tough tasks like loading logs.

3. Optional Hi-Vis coupler makes K-Series Loaders more versatile by picking up a broad range of Worksite Pro™ and other attachments from the comfort of the cab.

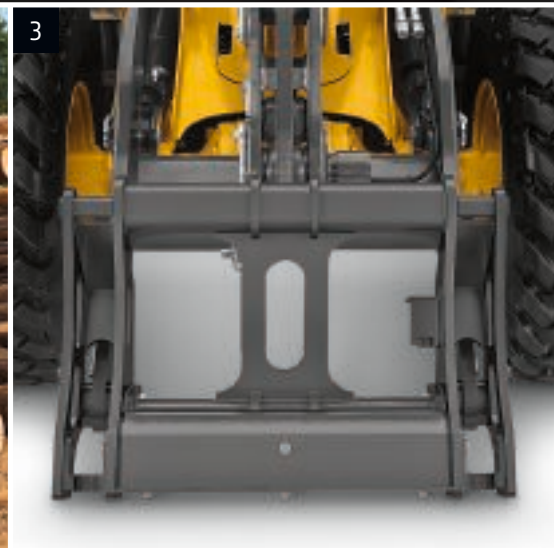
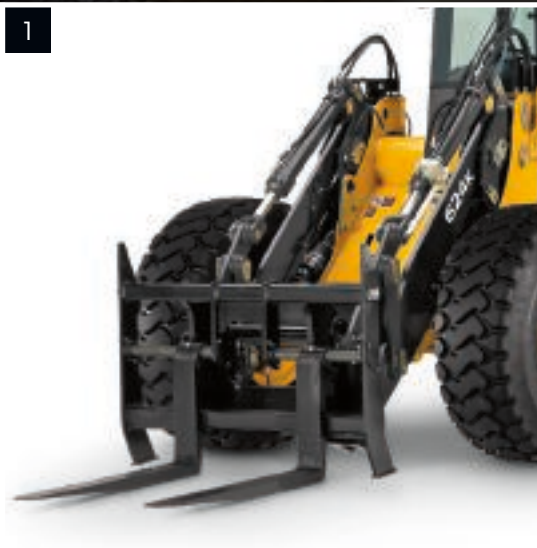

# It's a powerful hybrid of efficiency, value, and applied customer thinking.

Our 644K Hybrid Loader goes well beyond burning less fuel while reducing emissions — although with its PowerTech IT4 engine, hybrid-electric transmission, and brushless generator, it can boost fuel economy 25 percent. Designed with extensive customer input, it also delivers everyday operating advantages like consistently quick, smooth, and responsive hydraulics; fast ramp-climbing ability; and strong pushing power. And, it's nearly twice as quiet, both inside and outside the cab. Simply put, this hybrid will help make your operator more productive while making your operation more efficient.

The coast-control feature functions like dynamic braking in a hydrostatic transmission, slowing down the loader without touching a pedal and helping reduce service-brake component wear.

Running wide open at 1,800 rpm, in-cab sound levels are just 68 dBA. Noise is also less noticeable to bystanders, making this loader a good neighbor in residential areas.

The engine runs at a choice of three constant operator-selected rpms so boom and bucket functions are powerful, responsive, and quick while optimum fuel efficiency is maintained.

Purpose-built PowerShift transmission provides smooth moves through four forward speed ranges. Direction changes are performed by the electric motor, completely eliminating shifting in some truck-loading applications.

Its John Deere 6.8-L diesel runs at a constant operator-selected speed of 1,200, 1,500, or 1,800 rpm to reduce engine wear, noise levels, and fuel consumption.

Brushless A/C generator and motor, water-cooled brake resistor, and solid-state power electronics deliver long-term reliable performance.

1. Hybrid-electric drive recaptures energy while slowing the loader when the operator lets off the accelerator. This lessens the load on the engine, further reducing fuel consumption.





2. Strong pushing power and quick ramp-climbing ability make the 644K Hybrid an excellent choice for maintaining stockpiles and heaping hoppers in cement plants and other production facilities.

3. Our 644K Hybrid delivers up to 25-percent better average fuel efficiency than a conventional 644K with lockup torque converter. In applications like V-pattern truck loading, your fuel savings will be even greater.



# Discover your options.

K-Series Loaders come standard with plenty of production-boosting features to help you handle almost anything you throw their way. But yours isn't just any application, so we've got you covered with a wide variety of factory- or dealer-installed options. Equip your loader with exactly what you need to maximize your efforts and expand your opportunities.



1. Automatic differential lock engages as soon as a tire begins to slip. It's ideal for inexperienced operators or applications requiring high traction, such as stockpiling silage, plowing snow, and handling pipe.
2. With ride control, lift cylinders act as shock absorbers, cushioning bumps to allow navigation over rough ground quickly without losing material. Auto-actuation travel speed is adjustable from 1.5 to 24.0 kph (1.0 to 15.0 mph).
3. Worksite Pro couplers increase versatility and make attachment switchover pushbutton easy. Or go for the optional Hi-Vis coupler for high-visibility picking of a broad range of Deere and other attachments.



General-purpose or excavating buckets are available in pin-on or coupler configurations from 2.7–3.6 m<sup>3</sup> (3.5–4.75 cu. yd). Or opt for 1.22-, 1.52-, and 1.83-m (48 in., 60 in., and 72 in.) tines, depending on model.

Powered cab pre-cleaner is a smart addition in high airborne-debris environments.

Opt for the corrosion package to shield electrical components and connections, and help prevent corrosive materials from short-circuiting your productivity.

Need to take productivity to another level? High-Lift option extends lift height up to 356 mm (14 in.).

Heated mirrors prevent fog and ice from obstructing the view and affecting productivity.

Embedded payload scale enables you to fill each truck to its limit for maximum productivity. It's available on all Z-Bar and High-Lift loaders.

Full-tire front and rear fenders and flaps help keep the machine free of mud and debris.

Optional right-side steps are slip resistant, providing safe access to the cab.

Not all options are available on all loaders, so see your dealer for details.



# Nothing runs — or is built — like a Deere.

It's all about uptime. So we gave all three K-Loaders — including the 644K Hybrid — traditional John Deere durability features. They boast standard heavy-duty wet-sleeve diesels, Quad-Cool, and solid-state electrical systems. Other uptime-boosting features include reinforced articulation joints with double-tapered roller bearings, and booms and mainframes so tough they're warranted for three years or 10,000 hours. When you know how they're built, you'll run a Deere.



Electrical-distribution center employs reliable circuit-board technology and solid-state switches to eliminate many wiring harnesses, fuses, relays, and connectors. Sealed gold-pin electrical connectors resist corrosion for long-term integrity.

Standard features like bypass-start protection, automatic park brake, and convenient handholds help keep the operator out of harm's way. All models feature slip-resistant steps and platforms on both sides of the machine to provide safer access.

John Deere PowerTech EPA FT4/EU Stage IV diesel engines meet emission regulations without sacrificing power or torque. A PowerTech IT4/Stage IIIB diesel and a brushless electrical generator power the 644K Hybrid.

1. Optional programmable fan automatically reverses at predetermined intervals, ejecting debris from the radiator and cooler cores. Or choose your own cleaning cycles through the monitor.

2. Quad-Cool places the radiator, air conditioner, condenser, intercooler; and hydraulic, transmission, and standard axle coolers in a unique boxed configuration that's isolated from engine heat. Expect increased efficiency and durability.

3. Planetary final drives are mounted inboard. Hydraulic wet-disc brakes on all models are self-adjusting.



Sealed-switch module keeps out dust, moisture, and debris, and virtually never wears out. Proven marine-grade touchpad eliminates rocker switches and nearly 100 wires, keeping things simple and durable.

Four steel plates support the loader tower, extending pin life and protecting the boom-cylinder hoses.

Standard starter protection limits cranking time and requires cool-down periods between attempts.

Wet-sleeve engine liners provide uniform engine cooling for less oil breakdown and longer durability than cast-in-block designs.

Wide-mouth fuel tank allows quick and convenient ground-level fill-ups — generous tank capacity lets you work longer.

Heavy-duty axles employ cooling, filtration, and temperature monitoring to increase durability.

# Stretches your dollars, not your service techs.

Controlling daily owning and operating costs shouldn't be a reach — and it's not on a K-Series Loader. Same-side ground-level service points make quick work of the daily routine. The unique Quad-Cool system provides wide-open access to both sides of the coolers for easy cleanout. Extended service intervals let you work longer between changes. And because no maintenance beats low maintenance, standard self-adjusting serpentine engine belts, and wet-disc brakes seldom, if ever, require attention. That's just for starters. The list of K-Series features that help minimize maintenance goes on and on. And so will the owning and operating cost savings you'll enjoy.



1. Vertical spin-on filters allow quick, no-spill changes. Extended 500-, 2,000-, and 4,000-hour engine, transmission, and hydraulic oil-service intervals help reduce operating costs.
2. Ground-level fuel and diesel exhaust fluid (DEF) fill access help speed servicing for more uptime. There's also an available fast-fuel option.
3. If something goes wrong, the easy-to-navigate LCD monitor displays diagnostic messages and offers possible solutions to help get you back up and running quickly.
4. Color-coded fluid-sample and diagnostic test ports help speed preventive maintenance and troubleshooting. Noninvasive design helps keep out contaminants.
5. Conveniently located, easy-to-read sight gauges and see-through reservoirs let you check transmission, hydraulic, coolant, and windshield washer fluid levels at a glance.
6. Lockable compartment opens wide, offering convenient ground-level access to remote-start battery terminals and the electrical-disconnect switch.

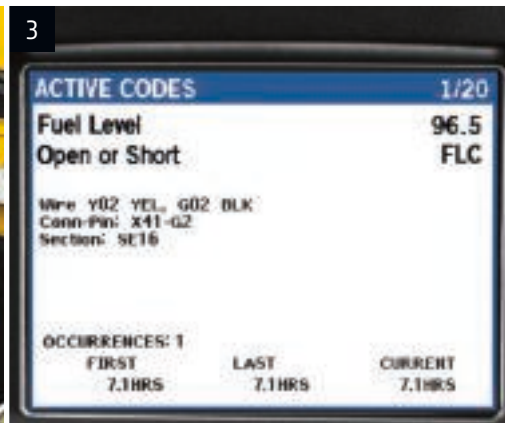
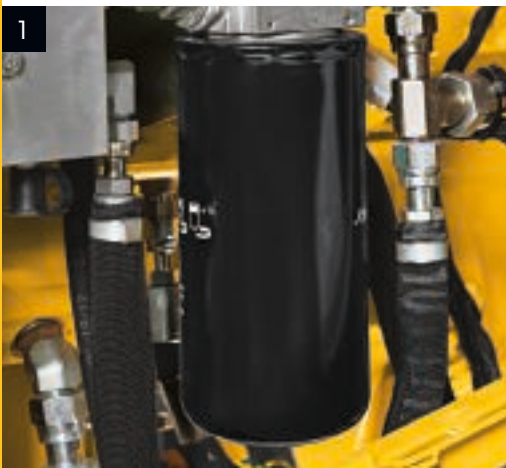





Greasing is less messy thanks to centralized lube banks that provide easy access to zerks. Conveniently located periodic lube and maintenance chart ensures nothing gets overlooked.

Inboard planetary final drives and self-adjusting wet-disc brakes are virtually maintenance-free.

Hydraulically driven fan runs only as needed for efficient cooling. Helps conserve fuel, too.

All daily service points including fueling are grouped on the left side for quick and convenient ground-level access.

Ash-service intervals for the diesel particulate filter (DPF) are condition based, so changing it may not be necessary until the first engine overhaul. Intervals can be extended further depending on application, regular maintenance practices, and the use of recommended fluids and lubricants.

Three-mm side-shield perforations block most airborne debris. Unlike stacked coolers, Quad-Cool cores resist plugging and are easily accessible from either side for quick and easy cleanout.

Auto-idle automatically reduces engine speed to help conserve fuel after an operator-determined period of inactivity. Auto shutdown turns off the engine after extended inactivity.



4



5



6

# 624K



DEERE

| Engine   |  | 624K Z-BAR / HIGH-LIFT / POWERLLE™ / TOOL CARRIER                   |   |                      |
|--|--|---|---|----------------------|
| Manufacturer and Model                                     | John Deere PowerTech™ PVX 6068   | John Deere PowerTech™ Plus 6068H                                    | John Deere PowerTech™ 6068H   |                      |
| Non-Road Emission Standard                                 | EPA Final Tier 4/EU Stage IV   | EPA Tier 3/EU Stage IIIA  | EPA Tier 2/EU Stage II  |                      |
| Cylinders  | 6  | 6   | 6   |                      |
| Valves Per Cylinder  | 4  | 4   | 4   |                      |
| Displacement   | 6.8 L (414 cu. in.)  | 6.8 L (414 cu. in.)   | 6.8 L (414 cu. in.)   |                      |
| Net Peak Power (ISO 9249)                                  | 139 kW (186 hp) at 1,800 rpm   | 147 kW (198 hp) at 1,800 rpm  | 147 kW (198 hp) at 1,800 rpm  |                      |
| Net Peak Torque (ISO 9249)                                 | 826 Nm (609 lb.-ft.) at 1,300 rpm  | 836 Nm (617 lb.-ft.) at 1,600 rpm                                   | 836 Nm (617 lb.-ft.) at 1,600 rpm                                   |                      |
| Net Torque Rise  | 57%  | 65%   | 65%   |                      |
| Fuel System (electronically controlled)                    | High-pressure common rail  | High-pressure common rail   | High-pressure common rail   |                      |
| Lubrication  | Full-flow spin-on filter and integral cooler   | Full-flow spin-on filter and integral cooler                        | Full-flow spin-on filter and integral cooler                        |                      |
| Aspiration   | Turbocharged, charge air cooled  | Turbocharged, charge air cooled                                     | Turbocharged, charge air cooled                                     |                      |
| Air Cleaner  | Under-hood, dual-element dry type,   | restriction indicator in cab monitor for service                    |   |                      |
| Fan Drive  | Hydraulically driven, proportionally controlled, fan aft of coolers  | Hydraulically driven, proportionally controlled, fan aft of coolers | Hydraulically driven, proportionally controlled, fan aft of coolers |                      |
| Electrical System  | 24 volt with 130-amp alternator  | 24 volt with 80-amp (100-amp optional) alternator                   | 24 volt with 80-amp (100-amp optional) alternator                   |                      |
| Batteries (2 – 12 volt)                                    | 950 CCA (each)   | 950 CCA (each)  | 950 CCA (each)  |                      |
| Transmission System  |  |   |   |                      |
| Type   | Countershaft-type PowerShift™  |   |   |                      |
| Torque Converter   | Single stage, single phase   |   |   |                      |
| Shift Control  | Electronically modulated, adaptive, load and speed dependent   |   |   |                      |
| Operator Interface   | Steering-column or joystick-mounted F-N-R and gear-select lever; Quick-Shift button on hydraulic lever   |   |   |                      |
| Shift Modes  | Manual/auto (1st–D or 2nd–D); Quick-Shift button with 2 selectable modes: kick-down or kick-up/down; and 3 adjustable clutch-cutoff settings           |   |   |                      |
|  | <i>Standard 5-Speed with Lockup Torque Converter</i>   |   | <i>Optional 4-Speed</i>   |                      |
| Maximum Travel Speeds (with 20.5 R 25 tires)               | <i>Forward</i>   | <i>Reverse</i>  | <i>Forward</i>  | <i>Reverse</i>       |
| Range 1  | 5.9 km/h (3.7 mph)   | 6.3 km/h (3.9 mph)  | 7.6 km/h (4.7 mph)  | 7.6 km/h (4.7 mph)   |
| Range 2  | 10.5 km/h (6.5 mph)  | 10.5 km/h (6.5 mph)   | 12.5 km/h (7.8 mph)   | 13.0 km/h (8.1 mph)  |
| Range 3  | 16.1 km/h (10.0 mph)   | 26.2 km/h (16.3 mph)  | 25.0 km/h (15.5 mph)  | 25.7 km/h (16.0 mph) |
| Range 4  | 25.0 km/h (15.5 mph)   | N/A   | 39.5 km/h (24.5 mph)  | N/A                  |
| Range 5  | 40.0 km/h (24.9 mph)   | N/A   | N/A   | N/A                  |
| Axles/Brakes   |  |   |   |                      |
| Final Drives   | Heavy-duty inboard-mounted planetary   |   |   |                      |
| Differentials  | Hydraulic locking front with conventional rear – standard; dual locking front and rear – optional  |   |   |                      |
| Rear Axle Oscillation, Stop to Stop (with 20.5 R 25 tires) | 24 deg. (12 deg. each direction)   |   |   |                      |
| Service Brakes (conform to ISO 3450)                       | Hydraulically actuated, spring-retracted, self-adjusting, inboard sun-shaft mounted, oil-cooled, single disc   |   |   |                      |
| Parking Brakes (conform to ISO 3450)                       | Automatic spring-applied, hydraulically released, driveline-mounted, oil-cooled, multi disc  |   |   |                      |
| Tires/Wheels (see page 23 for complete tire adjustments)   |  |   |   |                      |
|  | <i>Tread Width</i>   |   | <i>Width Over Tires</i>   |                      |
| Michelin 20.5 R 25, 1 Star L-3                             | 2050 mm (80.7 in.)   |   | 2657 mm (104.6 in.)   |                      |
| Serviceability   |  |   |   |                      |
| Refill Capacities  | EPA FT4/EU Stage IV  | EPA Tier 3/EU Stage IIIA  | EPA Tier 2/EU Stage II  |                      |
| Fuel Tank with Lockable Cap                                | 299 L (79 gal.)  | 352 L (93 gal.)   | 352 L (93 gal.)   |                      |
| Diesel Exhaust Fluid (DEF)                                 | 19 L (20 qt.)  | N/A   | N/A   |                      |
| Cooling System   | 33.8 L (35.7 qt.)  | 27 L (29 qt.)   | 27 L (29 qt.)   |                      |
| Engine Oil with Vertical Spin-On Filter                    | 19.5 L (20.6 qt.)  | 19 L (20 qt.)   | 19 L (20 qt.)   |                      |
| Transmission Reservoir with Vertical Filter                | 22 L (23 qt.)  | 22 L (23 qt.)   | 22 L (23 qt.)   |                      |
| Axle Oil   |  |   |   |                      |
| Front  | 22 L (23 qt.)  | 22 L (23 qt.)   | 22 L (23 qt.)   |                      |
| Rear   | 17 L (18 qt.)  | 17 L (18 qt.)   | 17 L (18 qt.)   |                      |
| Hydraulic Reservoir and Filter                             | 105.2 L (27.8 gal.)  | 110 L (29 gal.)   | 110 L (29 gal.)   |                      |
| Park Brake Oil (wet disc)                                  | 0.3 L (10 oz.)   | 0.3 L (10 oz.)  | 0.3 L (10 oz.)  |                      |
| Hydraulic System/Steering                                  |  |   |   |                      |
| Pump (loader and steering)                                 | Variable-displacement, axial-piston pump; closed-center, pressure-compensating system  |   |   |                      |
| Maximum Rated Flow at 6895 kPa (1,000 psi) and 2,350 rpm   | 223 L/m (59 gpm)   |   |   |                      |
| System Relief Pressure (loader and steering)               | 24 821 kPa (3,675 psi)   |   |   |                      |
| Loader Controls  | 2-function valve; joystick control or fingertip controls; hydraulic-function enable/disable; optional 3rd- and 4th-function valve with auxiliary lever |   |   |                      |
| Steering (conforms to ISO 5010)                            |  |   |   |                      |
| Type   | Power, fully hydraulic   |   |   |                      |
| Articulation Angle   | 80-deg. arc (40 deg. each direction)   |   |   |                      |



| Hydraulic System/Steering <i>(continued)</i>            | 624K Z-BAR / HIGH-LIFT / POWERLIFT / TOOL CARRIER |           |           |              |
|---|---|-----------|-----------|--------------|
| Turning Radius (measured to centerline of outside tire) | 5.27 m (17 ft. 4 in.)                             |           |           |              |
| Hydraulic Cycle Times                                   | Z-Bar   | High-Lift | Powerlift | Tool Carrier |
| Raise   | 5.9 sec.  | 5.9 sec.  | 5.9 sec.  | 5.6 sec.     |
| Dump  | 1.3 sec.  | 1.3 sec.  | 1.4 sec.  | 3.0 sec.     |
| Lower (float down)                                      | 2.7 sec.  | 2.7 sec.  | 2.8 sec.  | 2.7 sec.     |
| Total   | 9.9 sec.  | 9.9 sec.  | 10.1 sec. | 11.3 sec.    |

**Dimensions and Specifications with Pin-On Bucket**

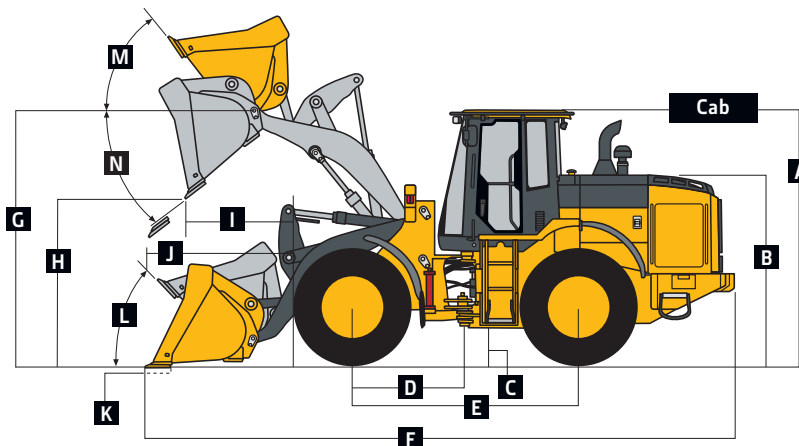

**624K Z-BAR AND HIGH-LIFT LOADERS WITH PIN-ON BUCKET**

|   | Z-Bar  | High-Lift  |
|---|--|--|
| <b>Dimensions with Bucket</b>   | 2.7-m <sup>3</sup> (3.5 cu. yd.) general-purpose with bolt-on edge | 2.7-m <sup>3</sup> (3.5 cu. yd.) general-purpose with bolt-on edge |
| A Height to Top of Cab  | 3.32 m (10 ft. 11 in.)   | 3.32 m (10 ft. 11 in.)   |
| B Hood Height   | 2.46 m (8 ft. 1 in.)   | 2.46 m (8 ft. 1 in.)   |
| C Ground Clearance  | 384 mm (15.1 in.)  | 384 mm (15.1 in.)  |
| D Length from Centerline to Front Axle  | 1.52 m (5 ft. 0 in.)   | 1.52 m (5 ft. 0 in.)   |
| E Wheelbase   | 3.09 m (10 ft. 1 in.)  | 3.09 m (10 ft. 1 in.)  |
| F Overall Length, Bucket on Ground  | 7.76 m (25 ft. 5 in.)  | 8.17 m (26 ft. 9 in.)  |
| G Height to Hinge Pin, Fully Raised   | 3.95 m (13 ft. 0 in.)  | 4.30 m (14 ft. 2 in.)  |
| H Dump Clearance, 45 deg., Full Height  | 2.86 m (9 ft. 5 in.)   | 3.23 m (10 ft. 7 in.)  |
| I Reach, 45-deg. Dump, Full Height  | 1.02 m (3 ft. 4 in.)   | 1.11 m (3 ft. 8 in.)   |
| J Reach, 45-deg. Dump, 2.13-m (7 ft. 0 in.) Clearance   | 1.57 m (5 ft. 2 in.)   | 1.93 m (6 ft. 4 in.)   |
| K Maximum Digging Depth   | 95 mm (3.8 in.)  | 203 mm (8.0 in.)   |
| L Maximum Rollback at Ground Level  | 37 deg.  | 36 deg.  |
| M Maximum Rollback, Boom Fully Raised   | 50 deg.  | 49 deg.  |
| N Maximum Bucket Dump Angle, Fully Raised   | 45 deg.  | 46 deg.  |
| Loader Clearance Circle, Bucket Carry Position  | 12.24 m (40 ft. 2 in.)   | 12.61 m (41 ft. 4 in.)   |
| <b>Specifications with Bucket</b>   |  |  |
| Capacity, Heaped  | 2.7 m <sup>3</sup> (3.5 cu. yd.)                                   | 2.7 m <sup>3</sup> (3.5 cu. yd.)                                   |
| Capacity, Struck  | 2.3 m <sup>3</sup> (3.0 cu. yd.)                                   | 2.3 m <sup>3</sup> (3.0 cu. yd.)                                   |
| Bucket Weight with Bolt-On Cutting Edge   | 1148 kg (2,532 lb.)  | 1148 kg (2,532 lb.)  |
| Bucket Width  | 2.69 m (8 ft. 10 in.)  | 2.69 m (8 ft. 10 in.)  |
| Breakout Force  | 12 821 kg (28,266 lb.)   | 11 662 kg (25,709 lb.)   |
| Tipping Load, Straight, No Tire Deflection  | 13 804 kg (30,433 lb.)   | 11 590 kg (25,552 lb.)   |
| Tipping Load, Straight, With Tire Deflection  | 13 005 kg (28,671 lb.)   | 11 007 kg (24,266 lb.)   |
| Tipping Load, 40-deg. Full Turn, No Tire Deflection   | 12 006 kg (26,469 lb.)   | 10 044 kg (22,143 lb.)   |
| Tipping Load, 40-deg. Full Turn, With Tire Deflection   | 10 956 kg (24,154 lb.)   | 9255 kg (20,404 lb.)   |
| Rated Operating Load, 50% Full-Turn Tipping Load, No Tire Deflection (conforms to ISO 14397-1)*   | 6003 kg (13,234 lb.)   | 5022 kg (11,072 lb.)   |
| Rated Operating Load, 50% Full-Turn Tipping Load, With Tire Deflection (conforms to ISO 14397-1)* | 5478 kg (12,077 lb.)   | 4627 kg (10,201 lb.)   |
| Operating Weight  | 15 747 kg (34,717 lb.)   | 15 948 kg (35,159 lb.)   |

Loader operating information is based on machine with identified linkage and standard equipment, PowerTech PVX 6068 (EPA Final Tier 4/EU Stage IV) engine, ROPS cab, rear cast bumper/counterweight, transmission side-frame guards, bottom guards, standard tires, full fuel tank, and 79-kg (175 lb.) operator. This information is affected by changes in tires, ballast, and different attachments.

\*Rated operating capacity based on Deere attachments only.

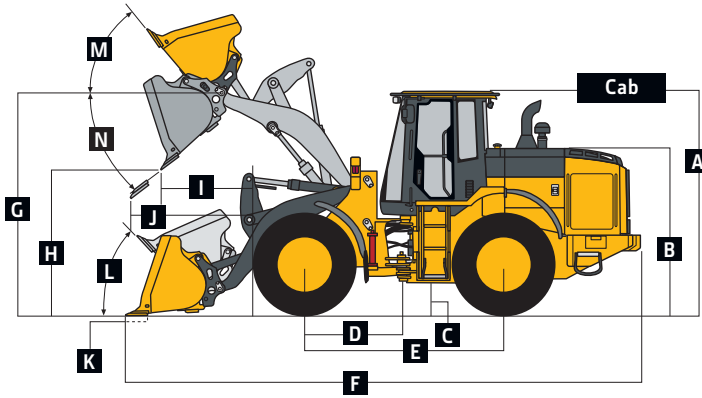

624K Z-BAR AND HIGH-LIFT LOADERS WITH QUICK-COUPLER AND HOOK-ON BUCKET

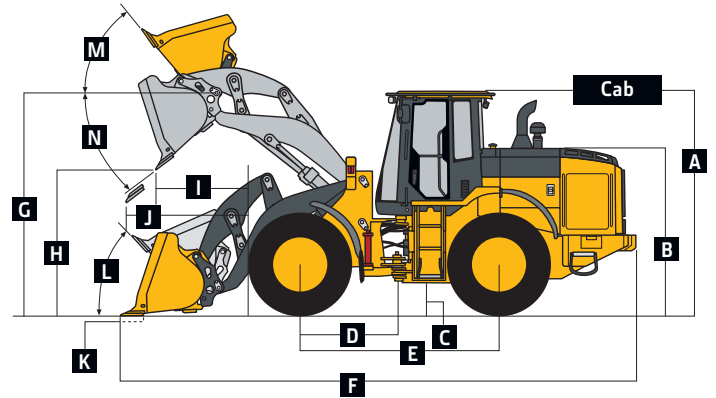

624K POWERLLEE LOADER WITH QUICK-COUPLER AND HOOK-ON BUCKET

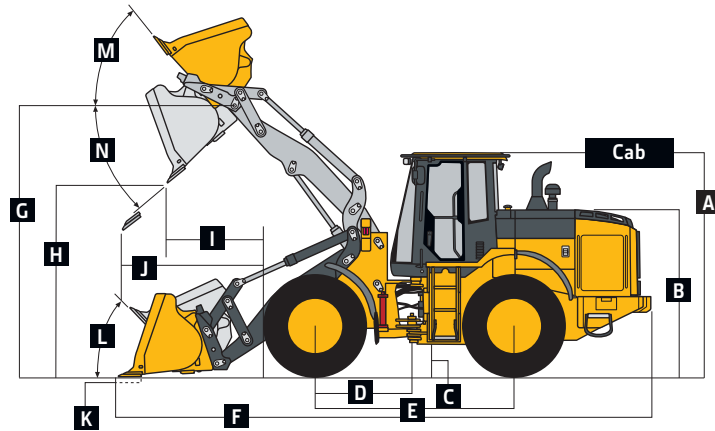

624K TOOL CARRIER LOADER WITH QUICK-COUPLER AND HOOK-ON BUCKET

|  | Z-Bar  | Z-Bar   | High-Lift  | High-Lift   | Powerllee  | Powerllee   | Tool Carrier   | Tool Carrier  |
|--|--|---|--|---|--|---|--|---|
| <b>Dimensions with Bucket</b>                                | 2.7-m <sup>3</sup> (3.5 cu. yd.) general-purpose with bolt-on edge | 4.01-m <sup>3</sup> (5.25 cu. yd.) light-material with bolt-on edge | 2.7-m <sup>3</sup> (3.5 cu. yd.) general-purpose with bolt-on edge | 4.01-m <sup>3</sup> (5.25 cu. yd.) light-material with bolt-on edge | 2.7-m <sup>3</sup> (3.5 cu. yd.) general-purpose with bolt-on edge | 4.01-m <sup>3</sup> (5.25 cu. yd.) light-material with bolt-on edge | 2.7-m <sup>3</sup> (3.5 cu. yd.) general-purpose with bolt-on edge | 4.01-m <sup>3</sup> (5.25 cu. yd.) light-material with bolt-on edge |
| <b>A</b> Height to Top of Cab                                | 3.32 m (10 ft. 11 in.)   | 3.32 m (10 ft. 11 in.)  | 3.32 m (10 ft. 11 in.)   | 3.32 m (10 ft. 11 in.)  | 3.32 m (10 ft. 11 in.)   | 3.32 m (10 ft. 11 in.)  | 3.32 m (10 ft. 11 in.)   | 3.32 m (10 ft. 11 in.)  |
| <b>B</b> Hood Height   | 2.46 m (8 ft. 1 in.)   | 2.46 m (8 ft. 1 in.)  | 2.46 m (8 ft. 1 in.)   | 2.46 m (8 ft. 1 in.)  | 2.46 m (8 ft. 1 in.)   | 2.46 m (8 ft. 1 in.)  | 2.46 m (8 ft. 1 in.)   | 2.46 m (8 ft. 1 in.)  |
| <b>C</b> Ground Clearance                                    | 384 mm (15.1 in.)  | 384 mm (15.1 in.)   | 384 mm (15.1 in.)  | 384 mm (15.1 in.)   | 384 mm (15.1 in.)  | 384 mm (15.1 in.)   | 384 mm (15.1 in.)  | 384 mm (15.1 in.)   |
| <b>D</b> Length from Centerline to Front Axle                | 1.52 m (5 ft. 0 in.)   | 1.52 m (5 ft. 0 in.)  | 1.52 m (5 ft. 0 in.)   | 1.52 m (5 ft. 0 in.)  | 1.52 m (5 ft. 0 in.)   | 1.52 m (5 ft. 0 in.)  | 1.52 m (5 ft. 0 in.)   | 1.52 m (5 ft. 0 in.)  |
| <b>E</b> Wheelbase   | 3.09 m (10 ft. 1 in.)  | 3.09 m (10 ft. 1 in.)   | 3.09 m (10 ft. 1 in.)  | 3.09 m (10 ft. 1 in.)   | 3.09 m (10 ft. 1 in.)  | 3.09 m (10 ft. 1 in.)   | 3.09 m (10 ft. 1 in.)  | 3.09 m (10 ft. 1 in.)   |
| <b>F</b> Overall Length, Bucket on Ground                    | 7.98 m (26 ft. 2 in.)  | 8.09 m (26 ft. 6 in.)   | 8.39 m (27 ft. 6 in.)  | 8.50 m (27 ft. 11 in.)  | 8.13 m (26 ft. 8 in.)  | 8.42 m (27 ft. 7.5 in.)   | 7.95 m (26 ft. 1 in.)  | 8.19 m (26 ft. 10 in.)  |
| <b>G</b> Height to Hinge Pin, Fully Raised                   | 3.96 m (13 ft. 0 in.)  | 4.32 m (14 ft. 2 in.)   | 3.96 m (13 ft. 0 in.)  | 4.32 m (14 ft. 2 in.)   | 3.99 m (13 ft. 1 in.)  | 3.99 m (13 ft. 1 in.)   | 3.99 m (13 ft. 1 in.)  | 3.99 m (13 ft. 1 in.)   |
| <b>H</b> Dump Clearance, 45 deg., Full Height                | 2.69 m (8 ft. 10 in.)  | 2.56 m (8 ft. 5 in.)  | 3.06 m (10 ft. 1 in.)  | 2.90 m (9 ft. 6 in.)  | 2.70 m (8 ft. 10 in.)  | 2.55 m (8 ft. 4 in.)  | 2.81 m (9 ft. 3 in.)   | 2.60 m (8 ft. 6 in.)  |
| <b>I</b> Reach, 45-deg. Dump, Full Height                    | 1.11 m (3 ft. 8 in.)   | 1.15 m (3 ft. 9 in.)  | 1.20 m (3 ft. 11 in.)  | 1.23 m (4 ft. 0 in.)  | 1.28 m (4 ft. 2 in.)   | 1.31 m (4 ft. 4 in.)  | 1.45 m (4 ft. 9 in.)   | 1.42 m (4 ft. 8 in.)  |
| <b>J</b> Reach, 45-deg. Dump, 2.13-m (7 ft. 0 in.) Clearance | 1.56 m (5 ft. 2 in.)   | 1.50 m (4 ft. 11 in.)   | 1.94 m (6 ft. 4 in.)   | 1.90 m (6 ft. 3 in.)  | 1.75 m (5 ft. 9 in.)   | 1.70 m (5 ft. 7 in.)  | 1.85 m (6 ft. 1 in.)   | 1.77 m (5 ft. 10 in.)   |
| <b>K</b> Maximum Digging Depth                               | 165 mm (6.5 in.)   | 257 mm (10.12 in.)  | 262 mm (10.3 in.)  | 358 mm (14.0 in.)   | 119 mm (4.7 in.)   | 228 mm (9.0 in.)  | 102 mm (4.0 in.)   | 225 mm (8.9 in.)  |
| <b>L</b> Maximum Rollback at Ground Level                    | 39 deg.  | 40 deg.   | 39 deg.  | 41 deg.   | 42 deg.  | 45 deg.   | 49 deg.  | 56 deg.   |
| <b>M</b> Maximum Rollback, Boom Fully Raised                 | 55 deg.  | 56 deg.   | 48 deg.  | 50 deg.   | 52 deg.  | 53 deg.   | 64 deg.  | 58.5 deg.   |
| <b>N</b> Maximum Bucket Dump Angle, Fully Raised             | 45 deg.  | 49 deg.   | 42 deg.  | 45 deg.   | 46 deg.  | 48 deg.   | 43 deg.  | 48 deg.   |
| Loader Clearance Circle, Bucket Carry Position               | 12.38 m (40 ft. 7 in.)   | 13.00 m (42 ft. 8 in.)  | 12.77 m (41 ft. 11 in.)  | 13.36 m (43 ft. 10 in.)   | 12.60 m (41 ft. 4 in.)   | 12.90 m (42 ft. 4 in.)  | 12.26 m (40 ft. 3 in.)   | 12.55 m (41 ft. 2 in.)  |

**Dimensions and Specifications with Hi-Vis Coupler and Hook-On Bucket (continued)**

**624K Z-BAR / HIGH-LIFT / POWERLLEL / TOOL CARRIER**

| Specifications with Bucket  | Z-Bar<br>2.7-m <sup>3</sup> (3.5 cu. yd.) general-purpose with bolt-on edge | Z-Bar<br>4.01-m <sup>3</sup> (5.25 cu. yd.) light-material with bolt-on edge | High-Lift<br>2.7-m <sup>3</sup> (3.5 cu. yd.) general-purpose with bolt-on edge | High-Lift<br>4.01-m <sup>3</sup> (5.25 cu. yd.) light-material with bolt-on edge | Powerllel<br>2.7-m <sup>3</sup> (3.5 cu. yd.) general-purpose with bolt-on edge | Powerllel<br>4.01-m <sup>3</sup> (5.25 cu. yd.) light-material with bolt-on edge | Tool Carrier<br>2.7-m <sup>3</sup> (3.5 cu. yd.) general-purpose with bolt-on edge | Tool Carrier<br>4.01-m <sup>3</sup> (5.25 cu. yd.) light-material with bolt-on edge |
|---|---|--|---|--|---|--|--|---|
| Capacity, Heaped  | 2.7 m <sup>3</sup><br>(3.5 cu. yd.)   | 4.0 m <sup>3</sup><br>(5.25 cu. yd.)   | 2.7 m <sup>3</sup><br>(3.5 cu. yd.)   | 4.0 m <sup>3</sup><br>(5.25 cu. yd.)   | 2.7 m <sup>3</sup><br>(3.5 cu. yd.)   | 4.0 m <sup>3</sup><br>(5.25 cu. yd.)   | 2.7 m <sup>3</sup><br>(3.5 cu. yd.)  | 4.0 m <sup>3</sup><br>(5.25 cu. yd.)  |
| Capacity, Struck  | 2.3 m <sup>3</sup><br>(3.0 cu. yd.)   | 3.5 m <sup>3</sup><br>(4.6 cu. yd.)  | 2.3 m <sup>3</sup><br>(3.0 cu. yd.)   | 3.5 m <sup>3</sup><br>(4.6 cu. yd.)  | 2.3 m <sup>3</sup><br>(3.0 cu. yd.)   | 3.5 m <sup>3</sup><br>(4.6 cu. yd.)  | 2.3 m <sup>3</sup><br>(3.0 cu. yd.)  | 3.5 m <sup>3</sup><br>(4.6 cu. yd.)   |
| Bucket Weight with Bolt-On Cutting Edge   | 1532 kg<br>(3,378 lb.)  | 1890 kg<br>(4,167 lb.)   | 1532 kg<br>(3,378 lb.)  | 1890 kg<br>(4,167 lb.)   | 1562 kg<br>(3,444 lb.)  | 1913 kg<br>(4,217 lb.)   | 1077 kg<br>(2,375 lb.)   | 1724 kg<br>(3,801 lb.)  |
| Bucket Width  | 2.69 m<br>(8 ft. 10 in.)  | 3.05 m<br>(10 ft. 0 in.)   | 2.69 m<br>(8 ft. 10 in.)  | 3.05 m<br>(10 ft. 0 in.)   | 2.69 m<br>(8 ft. 10 in.)  | 3.05 m<br>(10 ft. 0 in.)   | 2.69 m<br>(8 ft. 10 in.)   | 3.05 m<br>(10 ft. 0 in.)  |
| Breakout Force  | 10 983 kg<br>(24,214 lb.)   | 9849 kg<br>(21,713 lb.)  | 9998 kg<br>(22,042 lb.)   | 9035 kg<br>(19,919 lb.)  | 10 759 kg<br>(23,719 lb.)   | 10 638 kg<br>(23,453 lb.)  | 10 978 kg<br>(24,202 lb.)  | 9826 kg<br>(21,663 lb.)   |
| Tipping Load, Straight, No Tire Deflection  | 12 357 kg<br>(27,242 lb.)   | 11 924 kg<br>(26,288 lb.)  | 10 419 kg<br>(22,969 lb.)   | 10 001 kg<br>(22,048 lb.)  | 10 803 kg<br>(23,816 lb.)   | 10 299 kg<br>(22,705 lb.)  | 11 837 kg<br>(26,097 lb.)  | 11 337 kg<br>(24,994 lb.)   |
| Tipping Load, Straight, With Tire Deflection  | 11 661 kg<br>(25,708 lb.)   | 11 199 kg<br>(24,689 lb.)  | 9900 kg<br>(21,826 lb.)   | 9540 kg<br>(21,032 lb.)  | 10 251 kg<br>(22,600 lb.)   | 9729 kg<br>(21,449 lb.)  | 11 169 kg<br>(24,623 lb.)  | 10 659 kg<br>(23,499 lb.)   |
| Tipping Load, 40-deg. Full Turn, No Tire Deflection   | 10 694 kg<br>(23,577 lb.)   | 10 278 kg<br>(22,659 lb.)  | 8975 kg<br>(19,786 lb.)   | 8573 kg<br>(18,900 lb.)  | 9312 kg<br>(20,530 lb.)   | 8835 kg<br>(19,478 lb.)  | 10 253 kg<br>(22,605 lb.)  | 9774 kg<br>(21,548 lb.)   |
| Tipping Load, 40-deg. Full Turn, With Tire Deflection   | 9768 kg<br>(21,535 lb.)   | 9318 kg<br>(20,542 lb.)  | 8268 kg<br>(18,228 lb.)   | 7827 kg<br>(17,255 lb.)  | 8547 kg<br>(18,843 lb.)   | 8064 kg<br>(17,778 lb.)  | 9354 kg<br>(20,622 lb.)  | 8862 kg<br>(19,537 lb.)   |
| Rated Operating Load, 50% Full-Turn Tipping Load, No Tire Deflection (conforms to ISO 14397-1)*   | 5347 kg<br>(11,788 lb.)   | 5139 kg<br>(11,329 lb.)  | 4487 kg<br>(9,893 lb.)  | 4286 kg<br>(9,449 lb.)   | 4656 kg<br>(10,265 lb.)   | 4417 kg<br>(9,738 lb.)   | 5127 kg<br>(11,302 lb.)  | 4887 kg<br>(10,774 lb.)   |
| Rated Operating Load, 50% Full-Turn Tipping Load, With Tire Deflection (conforms to ISO 14397-1)* | 4884 kg<br>(10,767 lb.)   | 4659 kg<br>(10,271 lb.)  | 4134 kg<br>(9,114 lb.)  | 3913 kg<br>(8,627 lb.)   | 4273 kg<br>(9,420 lb.)  | 4032 kg<br>(8,889 lb.)   | 4677 kg<br>(10,311 lb.)  | 4431 kg<br>(9,769 lb.)  |
| Operating Weight  | 16 152 kg<br>(35,608 lb.)   | 16 477 kg<br>(36,325 lb.)  | 16 352 kg<br>(36,050 lb.)   | 16,678 kg<br>(36,769 lb.)  | 17 167 kg<br>(37,847 lb.)   | 17 472 kg<br>(38,519 lb.)  | 16 166 kg<br>(35,640 lb.)  | 16 482 kg<br>(36,336 lb.)   |

Loader operating information is based on machine with identified linkage and standard equipment, PowerTech PVX 6068 (EPA Final Tier 4/EU Stage IV) engine, ROPS cab, rear cast bumper/counterweight, transmission side-frame guards, bottom guards, standard tires, full fuel tank, and 79-kg (175 lb.) operator. This information is affected by changes in tires, ballast, and different attachments.

\*Rated operating capacity based on Deere attachments only.

**Bucket Selection Guides**

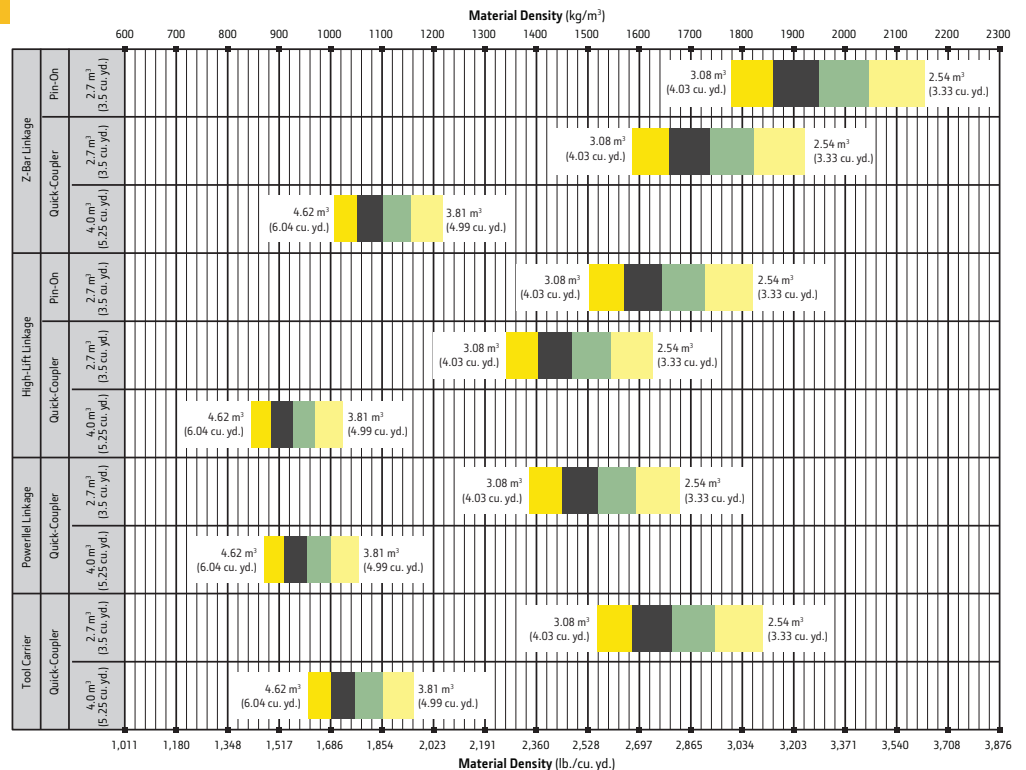

| LOOSE MATERIALS                  | kg/m <sup>3</sup> | lb./cu. yd. | LOOSE MATERIALS                                     | kg/m <sup>3</sup> | lb./cu. yd. |
|----------------------------------|-------------------|-------------|---|-------------------|-------------|
| Chips, pulpwood                  | 288               | 486         | Limestone, coarse, sized                            | 1570              | 2,646       |
| Cinders (coal, ashes, clinkers)  | 673               | 1,134       | Limestone, mixed sizes                              | 1682              | 2,835       |
| Clay and gravel, dry             | 1602              | 2,700       | Limestone, pulverized or crushed                    | 1362              | 2,295       |
| Clay, compact, solid             | 1746              | 2,943       | Sand, damp  | 2083              | 3,510       |
| Clay, dry in lump loose          | 1009              | 1,701       | Sand, dry   | 1762              | 2,970       |
| Clay, excavated in water         | 1282              | 2,160       | Sand, voids, full of water                          | 2083              | 3,510       |
| Coal, anthracite, broken, loose  | 865               | 1,450       | Sandstone, quarried                                 | 1314              | 2,214       |
| Coal, bituminous, moderately wet | 801               | 1,350       | Shale, broken crushed                               | 1362              | 2,295       |
| Earth, common loam, dry          | 1218              | 2,052       | Slag, furnace granulated                            | 1955              | 3,294       |
| Earth, mud, packed               | 1843              | 3,105       | Stone or gravel, 37.5 to 87.5-mm (1.5 to 3.5") size | 1442              | 2,430       |
| Granite, broken                  | 1538              | 2,592       | Stone or gravel, 18.75-mm (3/4") size               | 1602              | 2,700       |
| Gypsum                           | 2275              | 3,834       |   |                   |             |

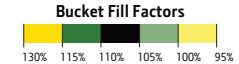

Dimensions and Specifications with  
Hi-Vis Coupler and Construction Forks 624K Z-BAR / HIGH-LIFT / POWERLLEL / TOOL CARRIER

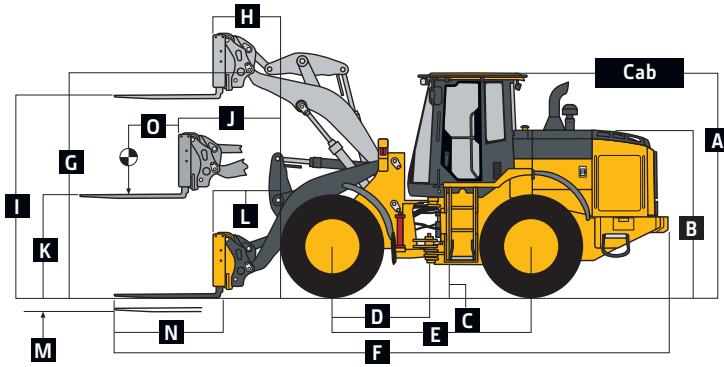

624K Z-BAR AND HIGH-LIFT LOADERS WITH QUICK-COUPLER  
AND HOOK-ON CONSTRUCTION FORKS

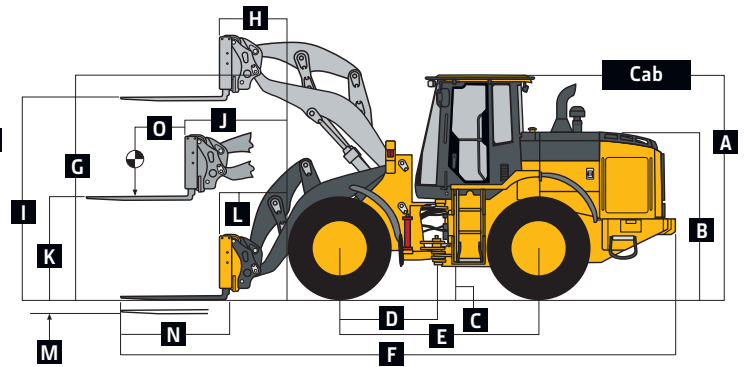

624K POWERLLEL LOADER WITH QUICK-COUPLER  
AND HOOK-ON CONSTRUCTION FORKS

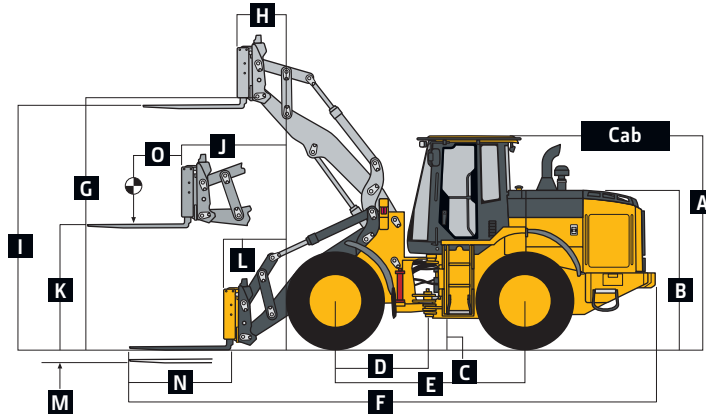

624K TOOL CARRIER LOADER WITH QUICK-COUPLER AND HOOK-ON CONSTRUCTION FORKS

|  | Z-Bar                          | Z-Bar                          | High-Lift                      | High-Lift                      | Powerllec                      | Powerllec                      | Tool Carrier                   | Tool Carrier                   |
|--|--------------------------------|--------------------------------|--------------------------------|--------------------------------|--------------------------------|--------------------------------|--------------------------------|--------------------------------|
| Dimensions with Forks                  | 1.22-m (48 in.)<br>tine length | 1.52-m (60 in.)<br>tine length | 1.22-m (48 in.)<br>tine length | 1.52-m (60 in.)<br>tine length | 1.22-m (48 in.)<br>tine length | 1.52-m (60 in.)<br>tine length | 1.22-m (48 in.)<br>tine length | 1.52-m (60 in.)<br>tine length |
| A Height to Top of Cab                 | 3.32 m (10 ft. 11 in.)         | 3.32 m (10 ft. 11 in.)         | 3.32 m (10 ft. 11 in.)         | 3.32 m (10 ft. 11 in.)         | 3.32 m (10 ft. 11 in.)         | 3.32 m (10 ft. 11 in.)         | 3.32 m (10 ft. 11 in.)         | 3.32 m (10 ft. 11 in.)         |
| B Hood Height                          | 2.46 m (8 ft. 1 in.)           | 2.46 m (8 ft. 1 in.)           | 2.46 m (8 ft. 1 in.)           | 2.46 m (8 ft. 1 in.)           | 2.46 m (8 ft. 1 in.)           | 2.46 m (8 ft. 1 in.)           | 2.46 m (8 ft. 1 in.)           | 2.46 m (8 ft. 1 in.)           |
| C Ground Clearance                     | 384 mm (15.1 in.)              | 384 mm (15.1 in.)              | 384 mm (15.1 in.)              | 384 mm (15.1 in.)              | 384 mm (15.1 in.)              | 384 mm (15.1 in.)              | 384 mm (15.1 in.)              | 384 mm (15.1 in.)              |
| D Length from Centerline to Front Axle | 1.52 m (5 ft. 0 in.)           | 1.52 m (5 ft. 0 in.)           | 1.52 m (5 ft. 0 in.)           | 1.52 m (5 ft. 0 in.)           | 1.52 m (5 ft. 0 in.)           | 1.52 m (5 ft. 0 in.)           | 1.52 m (5 ft. 0 in.)           | 1.52 m (5 ft. 0 in.)           |
| E Wheelbase                            | 3.09 m (10 ft. 1 in.)          | 3.09 m (10 ft. 1 in.)          | 3.09 m (10 ft. 1 in.)          | 3.09 m (10 ft. 1 in.)          | 3.09 m (10 ft. 1 in.)          | 3.09 m (10 ft. 1 in.)          | 3.09 m (10 ft. 1 in.)          | 3.09 m (10 ft. 1 in.)          |
| F Overall Length, Forks on Ground      | 8.18 m<br>(26 ft. 10 in.)      | 8.48 m<br>(27 ft. 10 in.)      | 8.60 m<br>(28 ft. 2 in.)       | 8.89 m<br>(29 ft. 2 in.)       | 8.30 m<br>(27 ft. 3 in.)       | 8.60 m<br>(28 ft. 3 in.)       | 8.02 m<br>(26 ft. 4 in.)       | 8.33 m<br>(27 ft. 4 in.)       |
| G Height to Hinge Pin, Fully Raised    | 3.96 m (13 ft. 0 in.)          | 4.32 m (14 ft. 2 in.)          | 3.99 m (13 ft. 1 in.)          | 0.84 m (33 in.)                | 3.99 m (13 ft. 1 in.)          | 0.92 m (36 in.)                | 3.99 m (13 ft. 1 in.)          | 0.89 m (35 in.)                |
| H Reach, Fully Raised                  | 0.75 m (29.5 in.)              | 0.84 m (33 in.)                | 0.92 m (36 in.)                | 0.89 m (35 in.)                | 0.75 m (29.5 in.)              | 0.84 m (33 in.)                | 0.75 m (29.5 in.)              | 0.84 m (33 in.)                |
| I Fork Height, Fully Raised            | 3.73 m (12 ft. 3 in.)          | 4.09 m (13 ft. 5 in.)          | 3.76 m (12 ft. 4 in.)          | 3.91 m (12 ft. 10 in.)         | 3.73 m (12 ft. 3 in.)          | 4.09 m (13 ft. 5 in.)          | 3.76 m (12 ft. 4 in.)          | 3.91 m (12 ft. 10 in.)         |
| J Maximum Reach, Fork Level            | 1.58 m (5 ft. 2 in.)           | 1.92 m (6 ft. 4 in.)           | 1.77 m (5 ft. 10 in.)          | 1.65 m (5 ft. 5 in.)           | 1.58 m (5 ft. 2 in.)           | 1.92 m (6 ft. 4 in.)           | 1.77 m (5 ft. 10 in.)          | 1.65 m (5 ft. 5 in.)           |
| K Fork Height, Maximum Reach           | 1.77 m (5 ft. 10 in.)          | 1.77 m (5 ft. 10 in.)          | 1.84 m (6 ft. 1 in.)           | 1.99 m (6 ft. 7 in.)           | 1.77 m (5 ft. 10 in.)          | 1.77 m (5 ft. 10 in.)          | 1.84 m (6 ft. 1 in.)           | 1.99 m (6 ft. 7 in.)           |
| L Reach, Ground Level                  | 0.96 m (3 ft. 2 in.)           | 1.40 m (4 ft. 7 in.)           | 1.11 m (3 ft. 8 in.)           | 0.88 m (35 in.)                | 0.96 m (3 ft. 2 in.)           | 1.40 m (4 ft. 7 in.)           | 1.11 m (3 ft. 8 in.)           | 0.88 m (35 in.)                |
| M Depth Below Ground                   | 23 mm (0.9 in.)                | 123 mm (4.8 in.)               | 19 mm (0.8 in.)                | 0 mm (0 in.)                   | 23 mm (0.9 in.)                | 123 mm (4.8 in.)               | 19 mm (0.8 in.)                | 0 mm (0 in.)                   |
| N Tine Length                          | 1.22 m<br>(48 in.)             | 1.52 m<br>(60 in.)             | 1.22 m<br>(48 in.)             | 1.52 m<br>(60 in.)             | 1.22 m<br>(48 in.)             | 1.52 m<br>(60 in.)             | 1.22 m<br>(48 in.)             | 1.52 m<br>(60 in.)             |
| O Load Position, 50% Tine Length       | 0.61 m<br>(24 in.)             | 0.76 m<br>(30 in.)             | 0.61 m<br>(24 in.)             | 0.76 m<br>(30 in.)             | 0.61 m<br>(24 in.)             | 0.76 m<br>(30 in.)             | 0.61 m<br>(24 in.)             | 0.76 m<br>(30 in.)             |

## Dimensions and Specifications with Hi-Vis Coupler and Construction Forks *(continued)*

### 624K Z-BAR / HIGH-LIFT / POWERLLEL / TOOL CARRIER

| Specifications with Forks  | Z-Bar<br>1.22-m (48 in.)<br>tine length | Z-Bar<br>1.52-m (60 in.)<br>tine length | High-Lift<br>1.22-m (48 in.)<br>tine length | High-Lift<br>1.52-m (60 in.)<br>tine length | Powerllep<br>1.22-m (48 in.)<br>tine length | Powerllep<br>1.52-m (60 in.)<br>tine length | Tool Carrier<br>1.22-m (48 in.)<br>tine length | Tool Carrier<br>1.52-m (60 in.)<br>tine length |
|--|---|---|---|---|---|---|--|--|
| Tipping Load, Straight, No Tire Deflection   | 9706 kg<br>(21,398 lb.)                 | 9185 kg<br>(20,249 lb.)                 | 8642 kg<br>(19,052 lb.)                     | 8215 kg<br>(18,111 lb.)                     | 9054 kg<br>(19,961 lb.)                     | 8595 kg<br>(18,949 lb.)                     | 9369 kg<br>(20,655 lb.)                        | 8889 kg<br>(19,597 lb.)                        |
| Tipping Load, Straight, With Tire Deflection   | 9420 kg<br>(20,767 lb.)                 | 8919 kg<br>(19,663 lb.)                 | 8397 kg<br>(18,512 lb.)                     | 7986 kg<br>(17,606 lb.)                     | 8778 kg<br>(19,532 lb.)                     | 8340 kg<br>(18,387 lb.)                     | 9102 kg<br>(20,066 lb.)                        | 8637 kg<br>(19,041 lb.)                        |
| Tipping Load, 40-deg. Full Turn, No Tire Deflection  | 8445 kg<br>(18,618 lb.)                 | 7985 kg<br>(17,604 lb.)                 | 7494 kg<br>(16,521 lb.)                     | 7116 kg<br>(15,688 lb.)                     | 7854 kg<br>(17,315 lb.)                     | 7446 kg<br>(16,416 lb.)                     | 8157 kg<br>(17,983 lb.)                        | 7731 kg<br>(17,044 lb.)                        |
| Tipping Load, 40-deg. Full Turn, With Tire Deflection  | 8052 kg<br>(17,752 lb.)                 | 7623 kg<br>(16,806 lb.)                 | 7155 kg<br>(15,774 lb.)                     | 6801 kg<br>(14,994 lb.)                     | 7473 kg<br>(16,745 lb.)                     | 7098 kg<br>(15,648 lb.)                     | 7776 kg<br>(17,143 lb.)                        | 7383 kg<br>(16,277 lb.)                        |
| Rated Operating Load, 50% Full-Turn Tipping Load, With Tire Deflection (conforms to ISO 14397-1 and SAE J1197)*      | 4026 kg<br>(8,876 lb.)                  | 3812 kg<br>(8,404 lb.)                  | 3578 kg<br>(7,888 lb.)                      | 3401 kg<br>(7,498 lb.)                      | 3737 kg<br>(8,239 lb.)                      | 3549 kg<br>(7,824 lb.)                      | 3888 kg<br>(8,572 lb.)                         | 3692 kg<br>(8,139 lb.)                         |
| Rated Operating Load, Rough Terrain, 60% Full-Turn Tipping Load, With Tire Deflection (conforms to EN474-3)*         | 4831 kg<br>(10,650 lb.)                 | 4574 kg<br>(10,084 lb.)                 | 4293 kg<br>(9,464 lb.)                      | 4081 kg<br>(8,997 lb.)                      | 4484 kg<br>(9,885 lb.)                      | 4259 kg<br>(9,389 lb.)                      | 4666 kg<br>(10,287 lb.)                        | 4430 kg<br>(9,767 lb.)                         |
| Rated Operating Load, Firm and Level Ground, 80% Full-Turn Tipping Load, With Tire Deflection (conforms to EN474-3)* | 6442 kg<br>(14,202 lb.)                 | 6098 kg<br>(13,444 lb.)                 | 5724 kg<br>(12,619 lb.)                     | 5441 kg<br>(11,995 lb.)                     | 5978 kg<br>(13,179 lb.)                     | 5678 kg<br>(12,518 lb.)                     | 6221 kg<br>(13,715 lb.)                        | 5906 kg<br>(13,020 lb.)                        |
| Operating Weight   | 15 730 kg<br>(34,679 lb.)               | 15 773 kg<br>(34,773 lb.)               | 15 931 kg<br>(35,122 lb.)                   | 15 971 kg<br>(35,210 lb.)                   | 16 702 kg<br>(36,822 lb.)                   | 16 745 kg<br>(36,916 lb.)                   | 15 703 kg<br>(34,619 lb.)                      | 15 746 kg<br>(34,714 lb.)                      |

Loader operating information is based on machine with identified linkage and standard equipment, PowerTech PVX 6068 (EPA Final Tier 4/EU Stage IV) engine, ROPS cab, rear cast bumper/counterweight, transmission side-frame guards, bottom guards, standard tires, full fuel tank, and 79-kg (175 lb.) operator. This information is affected by changes in tires, ballast, and different attachments.

\*Rated operating capacity based on Deere attachments only.

### Adjustments to Operating Weights and Tipping Loads with Buckets

Adjustments to operating weights, tipping loads, and tires are based on Z-bar machine with pin-on 2.7-m<sup>3</sup> (3.5 cu. yd.) general-purpose bucket with bolt-on cutting edge, ROPS cab, rear cast bumper/counterweight, transmission side-frame guards, bottom guards, standard tires, full fuel tank, and 79-kg (175 lb.) operator\*

| Add (+) or deduct (-) kg (lb.) as indicated for loaders with 3-piece rims | Operating Weight      | Tipping Load, Straight | Tipping Load, 40-deg. Full Turn SAE | Tread Width  | Width Over Tires  | Vertical Height    |
|---|-----------------------|------------------------|-------------------------------------|--------------|-------------------|--------------------|
| John Deere PowerTech PVX 6068   | 0 kg (0 lb.)          | 0 kg (0 lb.)           | 0 kg (0 lb.)                        | N/A          | N/A               | N/A                |
| John Deere PowerTech Plus 6068H   | -130 kg (-287 lb.)    | +38 kg (+84 lb.)       | 0 kg (0 lb.)                        | N/A          | N/A               | N/A                |
| John Deere PowerTech 6068H  | -146 kg (-322 lb.)    | -7 kg (-15 lb.)        | -45 kg (-101 lb.)                   | N/A          | N/A               | N/A                |
| Michelin 20.5 R 25, 1 Star L-3  | 0 kg (0 lb.)          | 0 kg (0 lb.)           | 0 kg (0 lb.)                        | 0 mm (0 in.) | 0 mm (0 in.)      | 0 mm (0 in.)       |
| Bridgestone 20.5 R 25, 1 Star L-3   | +44 kg (+97 lb.)      | +33 kg (+73 lb.)       | +29 kg (+64 lb.)                    | 0 mm (0 in.) | -16 mm (-0.6 in.) | 0 mm (0 in.)       |
| Titan 20.5 R 25, 1 Star L-3   | -4 kg (-9 lb.)        | -3 kg (-7 lb.)         | -3 kg (-7 lb.)                      | 0 mm (0 in.) | -16 mm (-0.6 in.) | 0 mm (0 in.)       |
| Michelin 20.5 R 25, 1 Star L-2  | -172 kg (-379 lb.)    | -129 kg (-285 lb.)     | -114 kg (-251 lb.)                  | 0 mm (0 in.) | -16 mm (-0.6 in.) | -3 mm (-0.1 in.)   |
| Bridgestone 20.5 R 25, 1 Star L-2   | -80 kg (-176 lb.)     | -60 kg (-132 lb.)      | -53 kg (-117 lb.)                   | 0 mm (0 in.) | -16 mm (-0.6 in.) | -3 mm (-0.1 in.)   |
| Titan 20.5 R 25, 1 Star L-2   | -128 kg (-282 lb.)    | -96 kg (-212 lb.)      | -85 kg (-187 lb.)                   | 0 mm (0 in.) | -16 mm (-0.6 in.) | -3 mm (-0.1 in.)   |
| Firestone 20.5-25, 16 PR L-3  | -252 kg (-556 lb.)    | -189 kg (-417 lb.)     | -167 kg (-367 lb.)                  | 0 mm (0 in.) | -12 mm (-0.5 in.) | +13 mm (+0.5 in.)  |
| Titan 20.5-25, 16 PR L-2  | -260 kg (-573 lb.)    | +195 kg (+430 lb.)     | -172 kg (-379 lb.)                  | 0 mm (0 in.) | -12 mm (-0.5 in.) | +6 mm (+0.2 in.)   |
| Firestone 20.5-25, 16 PR L-2  | -280 kg (-617 lb.)    | -210 kg (-464 lb.)     | -185 kg (-408 lb.)                  | 0 mm (0 in.) | -12 mm (-0.5 in.) | +6 mm (+0.2 in.)   |
| 20.5R25 L2 Sno-Plus Michelin  | -88 kg (-194 lb.)     | -66 kg (-145 lb.)      | -58 kg (-128 lb.)                   | 0 mm (0 in.) | +7 mm (+0.3 in.)  | -28 mm (-1.1 in.)  |
| 620/75R26 MegaXbib <sup>§</sup>   | -216 kg (-476 lb.)    | -162 kg (-357 lb.)     | -143 kg (-315 lb.)                  | 0 mm (0 in.) | +61 mm (+3.3 in.) | +27 mm (+1.06 in.) |
| CaCl <sub>2</sub> in 20.5-25, L-3 Rear Tires                              | +1166 kg (+2,571 lb.) | +1432 kg (+3,157 lb.)  | +1305 kg (+2,878 lb.)               | N/A          | N/A               | N/A                |

\*May change based on vehicle configuration, weight, or tire-pressure adjustments.

<sup>§</sup>Requires 8-deg. rear axle stops.

<sup>§</sup>Equipped with 1-piece rims.

# 644K



| Engine   |  | 644K Z-BAR / HIGH-LIFT / POWERLEL™                                      |   |  |  |                      |
|--|--|---|---|--|--|----------------------|
| Manufacturer and Model                                     | John Deere PowerTech™ PSX 6090   | John Deere PowerTech™ Plus 6068H  | John Deere PowerTech™ 6068H   | John Deere PowerTech PSX 6068                                | John Deere PowerTech PSX 6068                    |                      |
| Non-Road Emission Standard                                 | EPA Final Tier 4/EU Stage IV   | EPA Tier 3/EU Stage IIIA  | EPA Tier 2/EU Stage II  | EPA Interim Tier 4/EU Stage IIIB with Hybrid-Electric Drive  |  |                      |
| Cylinders  | 6  | 6   | 6   | 6  |  |                      |
| Valves Per Cylinder  | 4  | 4   | 4   | 4  |  |                      |
| Displacement   | 9.0 L (548 cu. in.)  | 6.8 L (414 cu. in.)   | 6.8 L (414 cu. in.)   | 6.8 L (414 cu. in.)  |  |                      |
| Net Peak Power (ISO 9249)                                  | 173 kW (232 hp) at 1,700 rpm   | 173 kW (232 hp) at 1,700 rpm  | 173 kW (232 hp) at 1,700 rpm  | 171 kW (229 hp) at 1,700 rpm                                 |  |                      |
| Net Peak Torque (ISO 9249)                                 | 1062 Nm (783 lb.-ft.) at 1,400 rpm   | 1016 Nm (749 lb.-ft.) at 1,400 rpm                                      | 1016 Nm (749 lb.-ft.) at 1,400 rpm  | 991 Nm (730 lb.-ft.) at 1,400 rpm                            |  |                      |
| Net Torque Rise  | 56%  | 55%   | 55%   | 19%  |  |                      |
| Fuel System (electronically controlled)                    | High-pressure common rail  | High-pressure common rail   | High-pressure common rail   | High-pressure common rail                                    |  |                      |
| Lubrication  | Full-flow spin-on filter and integral cooler   |   |   | Full-flow spin-on filter and integral cooler                 |  |                      |
| Aspiration   | Series turbocharged, charge air cooled   | Turbocharged, charge air cooled   | Turbocharged, charge air cooled   | Turbocharged, charge air cooled                              |  |                      |
| Air Cleaner  | Under-hood, dual-element dry type, restriction indicator in cab monitor for service  |   | Under-hood, dual-element dry type, restriction indicator in cab monitor for service               |  |  |                      |
| Fan Drive  | Hydraulically driven, proportionally controlled, fan aft of coolers  |   | Hydraulically driven, proportionally controlled, fan aft of coolers                               |  |  |                      |
| Electrical System  | 24 volt with 130-amp alternator  | 24 volt with 80-amp (100-amp optional) alternator                       |   | 24 volt with 100-amp (130-amp optional alternator)           |  |                      |
| Batteries (2 – 12 volt)                                    | 950 CCA (each)   | 950 CCA (each)  | 950 CCA (each)  | 950 CCA (each)   |  |                      |
| Transmission System  |  | EPA FT4/EU Stage IV / EPA Tier 3/EU Stage IIIA / EPA Tier 2/EU Stage II |   | EPA IT4/EU Stage IIIB with Hybrid-Electric Drive             |  |                      |
|  | <i>Standard 5-Speed with Lockup Torque Converter</i>   | <i>Optional 4-Speed</i>   |   | <i>Standard 3-Speed Hybrid-Electric Drive</i>                |  |                      |
| Type   | Countershaft-type PowerShift™  | Countershaft-type PowerShift  |   | Countershaft-type PowerShift                                 |  |                      |
| Torque Converter   | Single stage, single phase   | Single stage, single phase  |   | N/A  |  |                      |
| Motor/Generator  | N/A  | N/A   |   | Brushless A/C  |  |                      |
| Inverter   | N/A  | N/A   |   | Solid-state power  |  |                      |
| Shift Control  | Electronically modulated, adaptive, load and speed dependent   | Electronically modulated, adaptive, load and speed dependent            |   | Electronically modulated, adaptive, load and speed dependent |  |                      |
| Operator Interface   | Steering-column or joystick-mounted F-N-R and gear-select lever; Quick-Shift button on hydraulic lever                                       |   |   |  |  |                      |
| Shift Modes  | Manual/auto (1st-D or 2nd-D); Quick-Shift button with 2 selectable modes: kick-down or kick-up/down; and 3 adjustable clutch-cutoff settings |   |   |  |  |                      |
| Maximum Travel Speeds (with 23.5 R 25 tires)               | <i>Forward</i>   | <i>Reverse</i>  | <i>Forward</i>  | <i>Reverse</i>   | <i>Forward</i>                                   | <i>Reverse</i>       |
| Range 1  | 7.8 km/h (4.8 mph)   | 8.2 km/h (5.1 mph)  | 7.6 km/h (4.7 mph)  | 7.9 km/h (4.9 mph)   | 7.5 km/h (4.5 mph)                               | 7.5 km/h (4.5 mph)   |
| Range 2  | 13.4 km/h (8.3 mph)  | 13.6 km/h (8.5 mph)   | 12.6 km/h (7.8 mph)   | 12.9 km/h (8.0 mph)  | 14.0 km/h (8.7 mph)                              | 14.0 km/h (8.7 mph)  |
| Range 3  | 22.6 km/h (14.0 mph)   | 28.8 km/h (17.9 mph)  | 24.7 km/h (15.3 mph)  | 24.9 km/h (15.5 mph)   | 25.0 km/h (15.5 mph)                             | 25.0 km/h (15.5 mph) |
| Range 4  | 27.4 km/h (17.0 mph)   | N/A   | 36.6 km/h (22.7 mph)  | N/A  | 40.0 km/h (24.9 mph)                             | 40.0 km/h (24.9 mph) |
| Range 5  | 40.0 km/h (24.9 mph)   | N/A   | N/A   | N/A  | N/A  | N/A                  |
| Axles/Brakes   |  | EPA FT4/EU Stage IV / EPA Tier 3/EU Stage IIIA / EPA Tier 2/EU Stage II |   | EPA IT4/EU Stage IIIB with Hybrid-Electric Drive             |  |                      |
| Final Drives   | Heavy-duty inboard-mounted planetary   |   | Heavy-duty inboard-mounted planetary  |  |  |                      |
| Differentials  | Hydraulic locking front with conventional rear – standard; dual locking front and rear – optional  |   | Hydraulic locking front and rear – optional   |  |  |                      |
| Rear Axle Oscillation, Stop to Stop (with 23.5 R 25 tires) | 26 deg. (13 deg. each direction)   |   | 26 deg. (13 deg. each direction)  |  |  |                      |
| Service Brakes (conform to ISO 3450)                       | Hydraulically actuated, spring-retracted, self-adjusting, inboard sun-shaft mounted, oil-cooled, single disc                                 |   | Hydraulically actuated, inboard sun-shaft mounted, oil-cooled, self-adjusting, single disc        |  |  |                      |
| Parking Brakes (conform to ISO 3450)                       | Automatic spring-applied, hydraulically released, driveline-mounted, oil-cooled, multi disc  |   | Automatic spring-applied, hydraulically released, transmission-integrated, oil-cooled, multi disc |  |  |                      |
| Tires/Wheels (see page 28 for complete tire adjustments)   |  | EPA FT4/EU Stage IV / EPA Tier 3/EU Stage IIIA / EPA Tier 2/EU Stage II |   | EPA IT4/EU Stage IIIB with Hybrid-Electric Drive             |  |                      |
|  | <i>Tread Width</i>   | <i>Width Over Tires</i>   |   |  |  |                      |
| Michelin 23.5 R 25, 1 Star L-3                             | 2170 mm (85.4 in.)   | 2875 mm (113.2 in.)   |   |  |  |                      |
| Serviceability   |  | EPA FT4/EU Stage IV   |   | EPA Tier 3/EU Stage IIIA / EPA Tier 2/EU Stage II            |  |                      |
| Refill Capacities  | EPA FT4/EU Stage IV  |   | EPA Tier 3/EU Stage IIIA / EPA Tier 2/EU Stage II   |  | EPA IT4/EU Stage IIIB with Hybrid-Electric Drive |                      |
| Fuel Tank with Lockable Cap                                | 397 L (105 gal.)   | 352 L (93 gal.)   | 397 L (105 gal.)  |  |  |                      |
| Diesel Exhaust Fluid (DEF)                                 | 32 L (34 qt.)  | N/A   |   | N/A  |  |                      |
| Engine Cooling System                                      | 45.5 L (48.1 qt.)  | 29.5 L (31.2 qt.)   |   | 54.9 L (58 qt.)  |  |                      |
| Inverter Cooling System                                    | N/A  | N/A   |   | 5.7 L (6 qt.)  |  |                      |
| Engine Oil with Vertical Spin-On Filter                    | 28 L (29.5 qt.)  | 24.5 L (26 qt.)   |   | 27 L (28.5 qt.)  |  |                      |
| Transmission Reservoir with Vertical Filter                | 23 L (24 qt.)  | 27 L (28.5 qt.)   |   | 37.9 L (40 qt.)  |  |                      |
| Axle Oil (front and rear, each)                            | 22 L (23 qt.)  | 22 L (23 qt.)   |   | 22 L (23 qt.)  |  |                      |
| Hydraulic Reservoir and Filter                             | 105.2 L (27.8 gal.)  | 110 L (29 gal.)   |   | 106 L (28 gal.)  |  |                      |
| Park Brake Oil (wet disc)                                  | 0.6 L (20 oz.)   | 0.6 L (20 oz.)  |   | 0  |  |                      |





| Hydraulic System/Steering                                |  | 644K Z-BAR / HIGH-LIFT / POWERLLEL               |           |           |           |           |
|--|--|--|-----------|-----------|-----------|-----------|
| Pump (loader and steering)                               | Variable-displacement, axial-piston pump; closed-center, pressure-compensating system  |  |           |           |           |           |
| Maximum Rated Flow at 6895 kPa (1,000 psi) and 2,250 rpm | 297 L/m (78 gpm)   |  |           |           |           |           |
| System Relief Pressure (loader and steering)             | 25 166 kPa (3,650 psi)   |  |           |           |           |           |
| Loader Controls  | 2-function valve; joystick control or fingertip controls; hydraulic-function enable/disable; optional 3rd- and 4th-function valve with auxiliary lever |  |           |           |           |           |
| Steering (conforms to ISO 5010)                          |  |  |           |           |           |           |
| Type   | Power, fully hydraulic   |  |           |           |           |           |
| Articulation Angle                                       | 80-deg. arc (40 deg. each direction)   |  |           |           |           |           |
| Turning Radius (measured to centerline of outside tire)  | 5.57 m (18 ft. 3 in.)  |  |           |           |           |           |
|  | EPA FT4/EU Stage IV / EPA Tier 3/EU Stage IIIA / EPA Tier 2/EU Stage II  | EPA IT4/EU Stage IIIB with Hybrid-Electric Drive |           |           |           |           |
| Hydraulic Cycle Times                                    | Z-Bar  | High-Lift  | Powerllel | Z-Bar     | High-Lift | Powerllel |
| Raise  | 6.4 sec.   | 6.4 sec.   | 6.4 sec.  | 8.2 sec.  | 8.2 sec.  | 8.2 sec.  |
| Dump   | 1.6 sec.   | 1.6 sec.   | 2.1 sec.  | 2.3 sec.  | 2.3 sec.  | 2.8 sec.  |
| Lower (float down)                                       | 3.0 sec.   | 3.0 sec.   | 2.8 sec.  | 3.0 sec.  | 3.0 sec.  | 2.8 sec.  |
| Total  | 11.0 sec.  | 11.0 sec.  | 11.3 sec. | 13.5 sec. | 13.5 sec. | 13.8 sec. |

**Dimensions and Specifications with Pin-On Bucket**

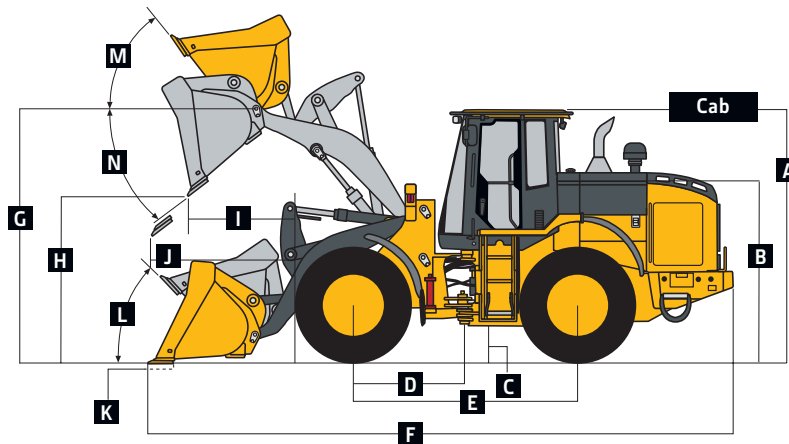

644K Z-BAR AND HIGH-LIFT LOADERS WITH PIN-ON BUCKET

|   | Z-Bar   | High-Lift   |
|---|---|---|
| <b>Dimensions with Bucket</b>   | 3.2-m <sup>3</sup> (4.25 cu. yd.) general-purpose with bolt-on edge | 3.2-m <sup>3</sup> (4.25 cu. yd.) general-purpose with bolt-on edge |
| A Height to Top of Cab  | 3.43 m (11 ft. 3 in.)   | 3.43 m (11 ft. 3 in.)   |
| B Hood Height   | 2.53 m (8 ft. 4 in.)  | 2.53 m (8 ft. 4 in.)  |
| C Ground Clearance  | 461 mm (18.1 in.)   | 461 mm (18.1 in.)   |
| D Length from Centerline to Front Axle  | 1.60 m (5 ft. 3 in.)  | 1.60 m (5 ft. 3 in.)  |
| E Wheelbase   | 3.26 m (10 ft. 8 in.)   | 3.26 m (10 ft. 8 in.)   |
| F Overall Length, Bucket on Ground  | 8.30 m (27 ft. 3 in.)   | 8.77 m (28 ft. 9 in.)   |
| G Height to Hinge Pin, Fully Raised   | 4.12 m (13 ft. 6 in.)   | 4.54 m (14 ft. 11 in.)  |
| H Dump Clearance, 45 deg., Full Height  | 2.91 m (9 ft. 6.5 in.)  | 3.33 m (10 ft. 11.1 in.)  |
| I Reach, 45-deg. Dump, Full Height  | 1.06 m (3 ft. 5.7 in.)  | 1.19 m (3 ft. 10.9 in.)   |
| J Reach, 45-deg. Dump, 2.13-m (7 ft. 0 in.) Clearance   | 1.61 m (5 ft. 3.4 in.)  | 2.06 m (6 ft. 9.1 in.)  |
| K Maximum Digging Depth   | 106 mm (4.2 in.)  | 200 mm (7.9 in.)  |
| L Maximum Rollback at Ground Level  | 42 deg.   | 41 deg.   |
| M Maximum Rollback, Boom Fully Raised   | 55 deg.   | 47 deg.   |
| N Maximum Bucket Dump Angle, Fully Raised   | 50 deg.   | 45 deg.   |
| Loader Clearance Circle, Bucket Carry Position  | 13.19 m (43 ft. 3.1 in.)  | 13.62 m (44 ft. 8.2 in.)  |
| <b>Specifications with Bucket</b>   |   |   |
| Capacity, Heaped  | 3.2 m <sup>3</sup> (4.25 cu. yd.)                                   | 3.2 m <sup>3</sup> (4.25 cu. yd.)                                   |
| Capacity, Struck  | 2.8 m <sup>3</sup> (3.7 cu. yd.)                                    | 2.8 m <sup>3</sup> (3.7 cu. yd.)                                    |
| Bucket Weight with Bolt-On Cutting Edge   | 1735 kg (3,826 lb.)   | 1736 kg (3,827 lb.)   |
| Bucket Width  | 3.04 m (10 ft. 0 in.)   | 3.04 m (10 ft. 0 in.)   |
| Breakout Force  | 15 378 kg (33,903 lb.)  | 13 782 kg (30,384 lb.)  |
| Tipping Load, Straight, No Tire Deflection  | 14 771 kg (32,565 lb.)  | 12 249 kg (27,004 lb.)  |
| Tipping Load, Straight, With Tire Deflection  | 13 923 kg (30,695 lb.)  | 11 628 kg (25,635 lb.)  |
| Tipping Load, 40-deg. Full Turn, No Tire Deflection   | 12 798 kg (28,214 lb.)  | 10 546 kg (23,250 lb.)  |
| Tipping Load, 40-deg. Full Turn, With Tire Deflection   | 11 739 kg (25,880 lb.)  | 9750 kg (21,495 lb.)  |
| Rated Operating Load, 50% Full-Turn Tipping Load, No Tire Deflection (conforms to ISO 14397-1)*   | 6398 kg (14,107 lb.)  | 6124 kg (13,502 lb.)  |
| Rated Operating Load, 50% Full-Turn Tipping Load, With Tire Deflection (conforms to ISO 14397-1)* | 5870 kg (12,941 lb.)  | 4875 kg (10,747 lb.)  |
| Operating Weight  | 18 682 kg (41,188 lb.)  | 19 091 kg (42,088 lb.)  |

Loader operating information is based on machine with identified linkage and standard equipment, PowerTech PSX 6090 (EPA Final Tier 4/EU Stage IV) engine, ROPS cab, rear cast bumper/counterweight, transmission side-frame guards, bottom guards, standard tires, full fuel tank, and 79-kg (175 lb.) operator. This information is affected by changes in tires, ballast, and different attachments.

\*Rated operating capacity based on Deere attachments only.

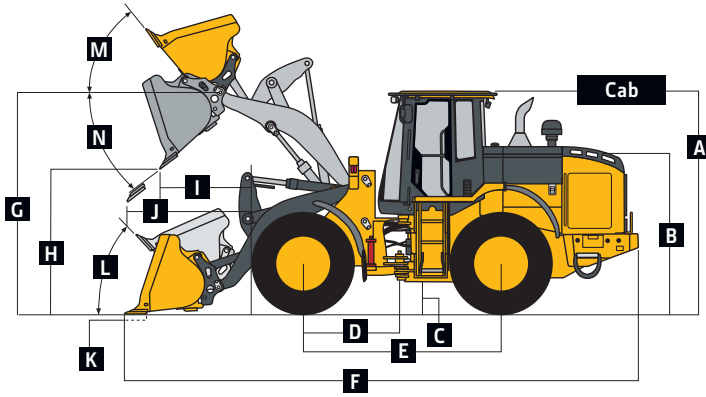

644K Z-BAR AND HIGH-LIFT LOADERS WITH QUICK-COUPLER  
AND HOOK-ON BUCKET

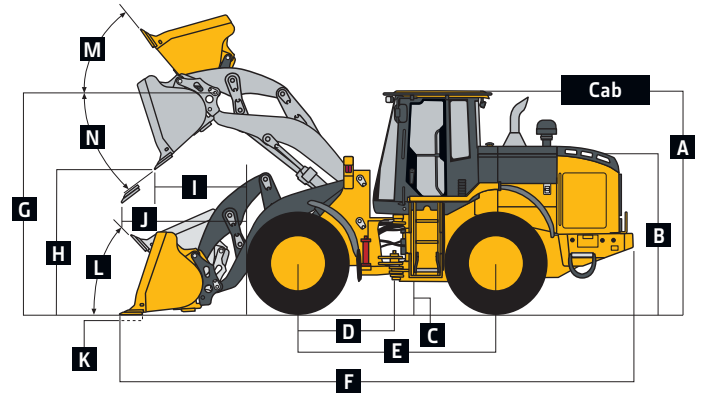

644K POWERLLEL LOADER WITH QUICK-COUPLER  
AND HOOK-ON BUCKET

|   | Z-Bar  | High-Lift  | Powerllel  |
|---|--|--|--|
| <b>Dimensions with Bucket</b>   | 3.1-m <sup>3</sup> (4.0 cu. yd.) general-purpose with bolt-on edge | 3.1-m <sup>3</sup> (4.0 cu. yd.) general-purpose with bolt-on edge | 3.1-m <sup>3</sup> (4.0 cu. yd.) general-purpose with bolt-on edge |
| <b>A</b> Height to Top of Cab   | 3.43 m (11 ft. 3 in.)  | 3.43 m (11 ft. 3 in.)  | 3.43 m (11 ft. 3 in.)  |
| <b>B</b> Hood Height  | 2.53 m (8 ft. 4 in.)   | 2.53 m (8 ft. 4 in.)   | 2.53 m (8 ft. 4 in.)   |
| <b>C</b> Ground Clearance   | 461 mm (18.1 in.)  | 461 mm (18.1 in.)  | 461 mm (18.1 in.)  |
| <b>D</b> Length from Centerline to Front Axle   | 1.60 m (5 ft. 3 in.)   | 1.60 m (5 ft. 3 in.)   | 1.60 m (5 ft. 3 in.)   |
| <b>E</b> Wheelbase  | 3.26 m (10 ft. 8 in.)  | 3.26 m (10 ft. 8 in.)  | 3.26 m (10 ft. 8 in.)  |
| <b>F</b> Overall Length, Bucket on Ground   | 8.27 m (27 ft. 2 in.)  | 8.74 m (28 ft. 8 in.)  | 8.50 m (27 ft. 11 in.)   |
| <b>G</b> Height to Hinge Pin, Fully Raised  | 4.12 m (13 ft. 6 in.)  | 4.54 m (14 ft. 11 in.)   | 4.12 m (13 ft. 6 in.)  |
| <b>H</b> Dump Clearance, 45 deg., Full Height   | 2.79 m (9 ft. 2 in.)   | 3.11 m (10 ft. 2 in.)  | 2.79 m (9 ft. 2 in.)   |
| <b>I</b> Reach, 45-deg. Dump, Full Height   | 1.16 m (3 ft. 10 in.)  | 1.28 m (4 ft. 2 in.)   | 1.20 m (3 ft. 11 in.)  |
| <b>J</b> Reach, 45-deg. Dump, 2.13-m (7 ft. 0 in.) Clearance                                      | 1.64 m (5 ft. 5 in.)   | 2.10 m (6 ft. 11 in.)  | 1.74 m (5 ft. 9 in.)   |
| <b>K</b> Maximum Digging Depth  | 139 mm (5.0 in.)   | 226 mm (9.0 in.)   | 91 mm (3.6 in.)  |
| <b>L</b> Maximum Rollback at Ground Level   | 42 deg.  | 42 deg.  | 41 deg.  |
| <b>M</b> Maximum Rollback, Boom Fully Raised  | 55 deg.  | 47 deg.  | 55 deg.  |
| <b>N</b> Maximum Bucket Dump Angle, Fully Raised  | 45 deg.  | 45 deg.  | 50 deg.  |
| Loader Clearance Circle, Bucket Carry Position  | 13.28 m (43 ft. 7 in.)   | 13.72 m (45 ft. 0 in.)   | 13.36 m (43 ft. 10 in.)  |
| <b>Specifications with Bucket</b>   |  |  |  |
| Capacity, Heaped  | 3.1 m <sup>3</sup> (4.0 cu. yd.)                                   | 3.1 m <sup>3</sup> (4.0 cu. yd.)                                   | 3.1 m <sup>3</sup> (4.0 cu. yd.)                                   |
| Capacity, Struck  | 2.7 m <sup>3</sup> (3.6 cu. yd.)                                   | 2.7 m <sup>3</sup> (3.6 cu. yd.)                                   | 2.6 m <sup>3</sup> (3.5 cu. yd.)                                   |
| Bucket Weight with Bolt-On Cutting Edge   | 2124 kg (4,682 lb.)  | 2124 kg (4,682 lb.)  | 2085 kg (4,597 lb.)  |
| Bucket Width  | 3.00 m (9 ft. 10 in.)  | 3.00 m (9 ft. 10 in.)  | 3.04 m (10 ft. 0 in.)  |
| Breakout Force  | 13 664 kg (30,124 lb.)   | 12 242 kg (26,989 lb.)   | 12 029 kg (26,519 lb.)   |
| Tipping Load, Straight, No Tire Deflection  | 13 401 kg (29,543 lb.)   | 11 155 kg (24,593 lb.)   | 12 923 kg (28,489 lb.)   |
| Tipping Load, Straight, With Tire Deflection  | 12 645 kg (27,877 lb.)   | 10 593 kg (23,353 lb.)   | 12 216 kg (26,932 lb.)   |
| Tipping Load, 40-deg. Full Turn, No Tire Deflection   | 11 556 kg (25,476 lb.)   | 9549 kg (21,051 lb.)   | 11 123 kg (24,523 lb.)   |
| Tipping Load, 40-deg. Full Turn, With Tire Deflection   | 10 605 kg (23,380 lb.)   | 8814 kg (19,431 lb.)   | 10 227 kg (22,547 lb.)   |
| Rated Operating Load, 50% Full-Turn Tipping Load, No Tire Deflection (conforms to ISO 14397-1)*   | 5778 kg (12,738 lb.)   | 4774 kg (10,525 lb.)   | 5562 kg (12,261 lb.)   |
| Rated Operating Load, 50% Full-Turn Tipping Load, With Tire Deflection (conforms to ISO 14397-1)* | 5303 kg (11,691 lb.)   | 4407 kg (9,716 lb.)  | 5114 kg (11,274 lb.)   |
| Operating Weight  | 19 074 kg (42,050 lb.)   | 19 482 kg (42,951 lb.)   | 20 269 kg (44,685 lb.)   |

Loader operating information is based on machine with identified linkage and standard equipment, PowerTech PSX 6090 (EPA Final Tier 4/EU Stage IV) engine, ROPS cab, rear cast bumper/counterweight, transmission side-frame guards, bottom guards, standard tires, full fuel tank, and 79-kg (175 lb.) operator. This information is affected by changes in tires, ballast, and different attachments.

\*Rated operating capacity based on Deere attachments only.

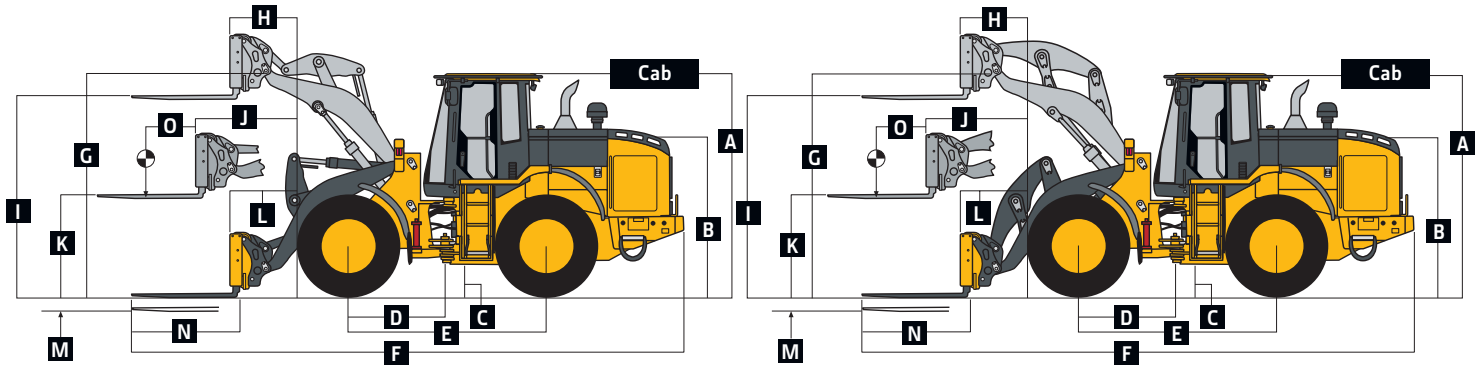

644K Z-BAR AND HIGH-LIFT LOADERS WITH QUICK-COUPLER  
AND HOOK-ON CONSTRUCTION FORKS

644K POWERLLEL LOADER WITH QUICK-COUPLER  
AND HOOK-ON CONSTRUCTION FORKS

|  | Z-Bar                          | Z-Bar                          | High-Lift                      | High-Lift                      | Powerllez                      | Powerllez                      | Powerllez                      |
|--|--------------------------------|--------------------------------|--------------------------------|--------------------------------|--------------------------------|--------------------------------|--------------------------------|
|  |                                |                                |                                |                                | Construction                   | Construction                   | Rockland<br>Logging            |
| <b>Dimensions with Forks</b>   | 1.52-m (60 in.)<br>tine length | 1.83-m (72 in.)<br>tine length | 1.52-m (60 in.)<br>tine length | 1.83-m (72 in.)<br>tine length | 1.52-m (60 in.)<br>tine length | 1.83-m (72 in.)<br>tine length | 1.52-m (60 in.)<br>tine length |
| <b>A</b> Height to Top of Cab  | 3.43 m<br>(11 ft. 3 in.)       | 3.43 m<br>(11 ft. 3 in.)       | 3.43 m<br>(11 ft. 3 in.)       | 3.43 m<br>(11 ft. 3 in.)       | 3.43 m<br>(11 ft. 3 in.)       | 3.43 m<br>(11 ft. 3 in.)       | 3.43 m<br>(11 ft. 3 in.)       |
| <b>B</b> Hood Height   | 2.53 m<br>(8 ft. 4 in.)        | 2.53 m<br>(8 ft. 4 in.)        | 2.53 m<br>(8 ft. 4 in.)        | 2.53 m<br>(8 ft. 4 in.)        | 2.53 m<br>(8 ft. 4 in.)        | 2.53 m<br>(8 ft. 4 in.)        | 2.53 m<br>(8 ft. 4 in.)        |
| <b>C</b> Ground Clearance  | 461 mm<br>(18.1 in.)           | 461 mm<br>(18.1 in.)           | 461 mm<br>(18.1 in.)           | 461 mm<br>(18.1 in.)           | 461 mm<br>(18.1 in.)           | 461 mm<br>(18.1 in.)           | 461 mm<br>(18.1 in.)           |
| <b>D</b> Length from Centerline to Front Axle  | 1.60 m<br>(5 ft. 3 in.)        | 1.45 m<br>(4 ft. 9 in.)        | 1.60 m<br>(5 ft. 3 in.)        | 1.45 m<br>(4 ft. 9 in.)        | 1.60 m<br>(5 ft. 3 in.)        | 1.45 m<br>(4 ft. 9 in.)        | 1.45 m<br>(4 ft. 9 in.)        |
| <b>E</b> Wheelbase   | 3.26 m<br>(10 ft. 8 in.)       | 2.93 m<br>(9 ft. 7 in.)        | 3.26 m<br>(10 ft. 8 in.)       | 2.93 m<br>(9 ft. 7 in.)        | 3.26 m<br>(10 ft. 8 in.)       | 2.93 m<br>(9 ft. 7 in.)        | 2.93 m<br>(9 ft. 7 in.)        |
| <b>F</b> Overall Length, Forks on Ground   | 8.81 m<br>(28 ft. 11 in.)      | 9.11 m<br>(29 ft. 11 in.)      | 9.28 m<br>(30 ft. 5.4 in.)     | 9.58 m<br>(31 ft. 5 in.)       | 9.04 m<br>(29 ft. 8 in.)       | 9.34 m<br>(30 ft. 8 in.)       | 9.13 m<br>(29 ft. 11 in.)      |
| <b>G</b> Height to Hinge Pin, Fully Raised   | 4.12 m<br>(13 ft. 6 in.)       | 4.12 m<br>(13 ft. 6 in.)       | 4.54 m<br>(14 ft. 11 in.)      | 4.54 m<br>(14 ft. 11 in.)      | 4.12 m<br>(13 ft. 6 in.)       | 4.12 m<br>(13 ft. 6 in.)       | 4.12 m<br>(13 ft. 6 in.)       |
| <b>H</b> Reach, Fully Raised   | 788 mm<br>(31.0 in.)           | 788 mm<br>(31.0 in.)           | 905 mm<br>(35.6 in.)           | 905 mm<br>(35.6 in.)           | 819 mm<br>(32.2 in.)           | 819 mm<br>(32.2 in.)           | 932 mm<br>(37.0 in.)           |
| <b>I</b> Fork Height, Fully Raised   | 3.89 m<br>(12 ft. 9 in.)       | 3.89 m<br>(12 ft. 9 in.)       | 4.22 m<br>(13 ft. 10.1 in.)    | 4.22 m<br>(13 ft. 10.1 in.)    | 3.79 m<br>(12 ft. 5 in.)       | 3.79 m<br>(12 ft. 5 in.)       | 3.83 m<br>(12 ft. 7 in.)       |
| <b>J</b> Maximum Reach, Fork Level   | 1.68 m<br>(5 ft. 6 in.)        | 1.68 m<br>(5 ft. 6 in.)        | 2.07 m<br>(6 ft. 9.5 in.)      | 2.07 m<br>(6 ft. 9.5 in.)      | 1.76 m<br>(5 ft. 9 in.)        | 1.76 m<br>(5 ft. 9 in.)        | 1.87 m<br>(6 ft. 2 in.)        |
| <b>K</b> Fork Height, Maximum Reach  | 1.71 m<br>(5 ft. 7 in.)        | 1.71 m<br>(5 ft. 7 in.)        | 1.86 m<br>(6 ft. 1.2 in.)      | 1.86 m<br>(6 ft. 1.2 in.)      | 1.71 m<br>(5 ft. 7 in.)        | 1.71 m<br>(5 ft. 7 in.)        | 1.76 m<br>(5 ft. 9 in.)        |
| <b>L</b> Reach, Ground Level   | 1.17 m<br>(3 ft. 10 in.)       | 1.17 m<br>(3 ft. 10 in.)       | 1.64 m<br>(5 ft. 4.6 in.)      | 1.64 m<br>(5 ft. 4.6 in.)      | 1.22 m<br>(4 ft. 0 in.)        | 1.22 m<br>(4 ft. 0 in.)        | 1.31 m<br>(4 ft. 4 in.)        |
| <b>M</b> Depth Below Ground  | 89 mm (4.0 in.)                | 89 mm (4.0 in.)                | 181 mm (7.1 in.)               | 181 mm (7.1 in.)               | 38 mm (1.5 in.)                | 38 mm (1.5 in.)                | 0 mm (0 in.)                   |
| <b>N</b> Tine Length   | 1.52 m (60 in.)                | 1.83 m (72 in.)                | 1.52 m (60 in.)                | 1.83 m (72 in.)                | 1.52 m (60 in.)                | 1.83 m (72 in.)                | 1.52 m (60 in.)                |
| <b>O</b> Load Position, 50% Tine Length  | 0.76 m (30 in.)                | 0.92 m (36 in.)                | 0.76 m (30 in.)                | 0.92 m (36 in.)                | 0.76 m (30 in.)                | 0.92 m (36 in.)                | 0.76 m (30 in.)                |
| <b>Specifications with Forks</b>   |                                |                                |                                |                                |                                |                                |                                |
| Tipping Load, Straight, No Tire Deflection   | 9883 kg<br>(21,789 lb.)        | 9373 kg<br>(20,663 lb.)        | 8791 kg<br>(19,381 lb.)        | 8369 kg<br>(18,449 lb.)        | 9892 kg<br>(21,807 lb.)        | 9388 kg<br>(20,697 lb.)        | 9632 kg<br>(21,235 lb.)        |
| Tipping Load, Straight, With Tire Deflection   | 9621 kg<br>(21,211 lb.)        | 9123 kg<br>(20,113 lb.)        | 8571 kg<br>(18,896 lb.)        | 8166 kg<br>(18,003 lb.)        | 9579 kg<br>(21,118 lb.)        | 9090 kg<br>(20,040 lb.)        | 9234 kg<br>(20,357 lb.)        |
| Tipping Load, 40-deg. Full Turn, No Tire Deflection  | 8562 kg<br>(18,876 lb.)        | 8110 kg<br>(17,880 lb.)        | 7571 kg<br>(16,691 lb.)        | 7198 kg<br>(15,868 lb.)        | 8557 kg<br>(18,866 lb.)        | 8112 kg<br>(17,884 lb.)        | 8209 kg<br>(18,097 lb.)        |
| Tipping Load, 40-deg. Full Turn, With Tire Deflection  | 8208 kg<br>(18,095 lb.)        | 7773 kg<br>(17,136 lb.)        | 7266 kg<br>(16,019 lb.)        | 6912 kg<br>(15,238 lb.)        | 8145 kg<br>(17,957 lb.)        | 7725 kg<br>(17,031 lb.)        | 7674 kg<br>(16,918 lb.)        |
| Rated Operating Load, 50% Full-Turn Tipping Load, With Tire Deflection (conforms to ISO 14397-1 and SAE J1197)*      | 4104 kg<br>(9,048 lb.)         | 3887 kg<br>(8,569 lb.)         | 3633 kg<br>(8,009 lb.)         | 3456 kg<br>(7,619 lb.)         | 4073 kg<br>(8,979 lb.)         | 3863 kg<br>(8,516 lb.)         | 3837 kg<br>(8,459 lb.)         |
| Rated Operating Load, Rough Terrain, 60% Full-Turn Tipping Load, With Tire Deflection (conforms to EN474-3)*         | 4925 kg<br>(10,858 lb.)        | 4664 kg<br>(10,282 lb.)        | 4360 kg<br>(9,612 lb.)         | 4147 kg<br>(9,143 lb.)         | 4887 kg<br>(10,774 lb.)        | 4635 kg<br>(10,218 lb.)        | 4604 kg<br>(10,150 lb.)        |
| Rated Operating Load, Firm and Level Ground, 80% Full-Turn Tipping Load, With Tire Deflection (conforms to EN474-3)* | 6567 kg<br>(14,476 lb.)        | 6219 kg<br>(13,710 lb.)        | 5813 kg<br>(12,815 lb.)        | 5530 kg<br>(12,192 lb.)        | 6516 kg<br>(14,365 lb.)        | 6180 kg<br>(13,626 lb.)        | 6139 kg<br>(13,534 lb.)        |
| Operating Weight   | 18 603 kg<br>(41,012 lb.)      | 18 663 kg<br>(41,144 lb.)      | 19 012 kg<br>(41,914 lb.)      | 19 072 kg<br>(42,046 lb.)      | 19 796 kg<br>(43,643 lb.)      | 19 856 kg<br>(43,775 lb.)      | 21 469 kg<br>(47,330 lb.)      |

Loader operating information is based on machine with identified linkage and standard equipment, PowerTech PSX 6090 (EPA Final Tier 4/EU Stage IV) engine, ROPS cab, rear cast bumper/counterweight, transmission side-frame guards, bottom guards, standard tires, full fuel tank, and 79-kg (175 lb.) operator. This information is affected by changes in tires, ballast, and different attachments.

\*Rated operating capacity based on Deere attachments only.

**Adjustments to Operating Weights and Tipping Loads with Buckets**

**644K Z-BAR / HIGH-LIFT / POWERLIFT**

Adjustments to operating weights, tipping loads, and tires are based on Z-bar machine with pin-on 3.1-m<sup>3</sup> (4.0 cu. yd.) general-purpose bucket with bolt-on cutting edge, ROPS cab, rear cast bumper/counterweight, transmission side-frame guards, bottom guards, standard tires, full fuel tank, and 79-kg (175 lb.) operator\*

| Add (+) or deduct (-) kg (lb.) as indicated for loaders with 3-piece rims | Operating Weight     | Tipping Load, Straight | Tipping Load, 40-deg. Full Turn SAE | Tread Width       | Width Over Tires   | Vertical Height   |
|---|----------------------|------------------------|-------------------------------------|-------------------|--------------------|-------------------|
| John Deere PowerTech PSX 6090   | 0 kg (0 lb.)         | 0 kg (0 lb.)           | 0 kg (0 lb.)                        | N/A               | N/A                | N/A               |
| John Deere PowerTech Plus 6068H   | -98 kg (-215 lb.)    | +338 kg (+745 lb.)     | +242 kg (+534 lb.)                  | N/A               | N/A                | N/A               |
| John Deere PowerTech 6068H  | -124 kg (-273 lb.)   | +293 kg (+646 lb.)     | +203 kg (+448 lb.)                  | N/A               | N/A                | N/A               |
| John Deere PowerTech PSX 6068 Z-Bar                                       | -341 kg (-753 lb.)   | -682 kg (-1,504 lb.)   | -554 kg (-1,222 lb.)                | N/A               | N/A                | N/A               |
| John Deere PowerTech PSX 6068 High Lift/PowerLift                         | +8 kg (+18 lb.)      | +14 kg (+30 lb.)       | +35 kg (+78 lb.)                    | N/A               | N/A                | N/A               |
| Michelin 23.5 R 25, 1 Star L-3  | 0 kg (0 lb.)         | 0 kg (0 lb.)           | 0 kg (0 lb.)                        | 0 mm (0 in.)      | 0 mm (0 in.)       | 0 mm (0 in.)      |
| Bridgestone 23.5 R 25, 1 Star L-3   | +116 kg (+256 lb.)   | +86 kg (+190 lb.)      | +76 kg (+167 lb.)                   | 0 mm (0 in.)      | -28 mm (-1.1 in.)  | +17 mm (+0.7 in.) |
| Titan 23.5 R 25, 20 PR L-3  | -156 kg (-343 lb.)   | -115 kg (-255 lb.)     | -102 kg (-224 lb.)                  | 0 mm (0 in.)      | +27 mm (+1.1 in.)  | 0 mm (0 in.)      |
| Titan 725/70-25 16-Ply L-4T (Logger Style) <sup>1§8</sup>                 | +266 kg (+587 lb.)   | +208 kg (+459 lb.)     | +183 kg (+404 lb.)                  | +37 mm (+1.5 in.) | +95 mm (+3.7 in.)  | +49 mm (+1.9 in.) |
| Michelin 750/65 R 25, 1 Star L-3T <sup>1§8</sup>                          | +622 kg (+1,371 lb.) | +472 kg (+1,041 lb.)   | +416 kg (+917 lb.)                  | +37 mm (+1.5 in.) | +158 mm (+6.2 in.) | +12 mm (+0.5 in.) |

\*May change based on vehicle configuration, weight, or tire-pressure adjustments.

<sup>1</sup>Equipped with 5-piece heavy-duty rims.

<sup>§</sup>CaCl<sub>2</sub> not recommended.

<sup>8</sup>Requires 9-deg. rear axle stops.

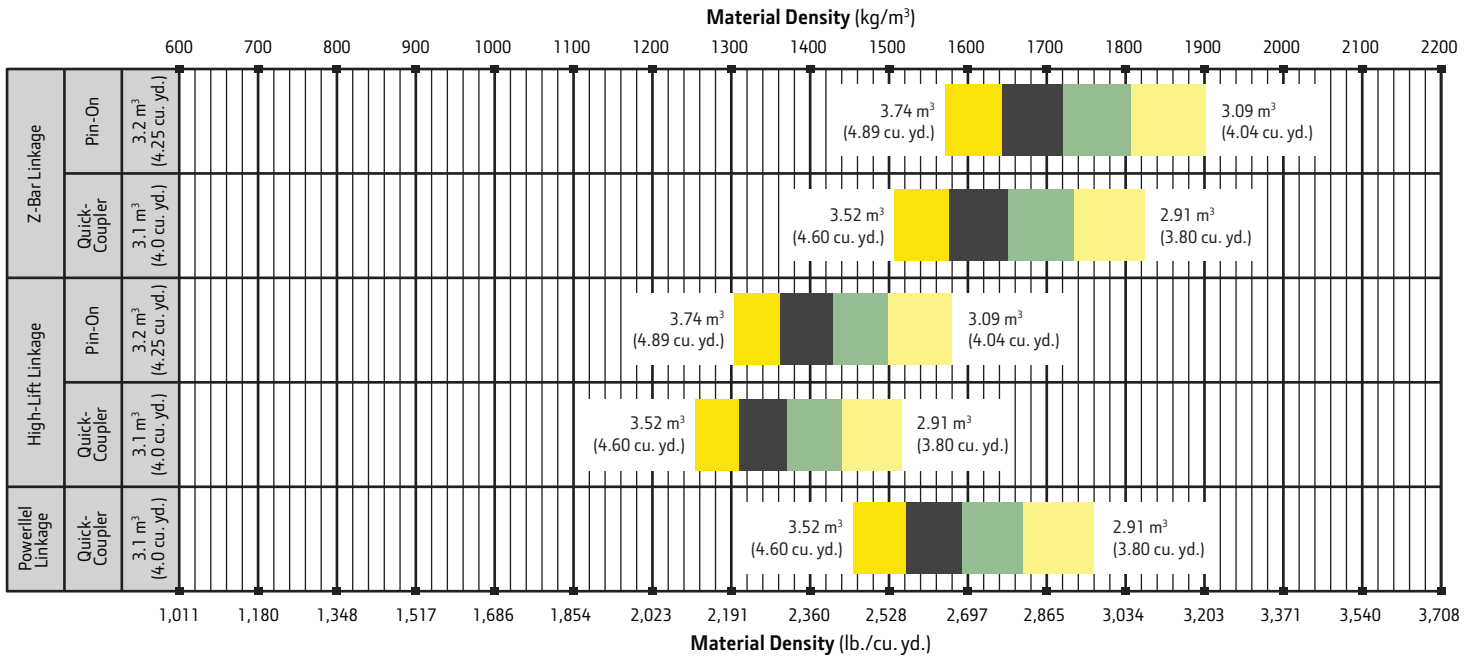

| LOOSE MATERIALS                  |      | kg/m³ | lb./cu. yd.   | LOOSE MATERIALS |       | kg/m³ | lb./cu. yd. |
|----------------------------------|------|-------|---|-----------------|-------|-------|-------------|
| Chips, pulpwood                  | 288  | 486   | Limestone, coarse, sized                            | 1570            | 2,646 |       |             |
| Cinders (coal, ashes, clinkers)  | 673  | 1,134 | Limestone, mixed sizes                              | 1682            | 2,835 |       |             |
| Clay and gravel, dry             | 1602 | 2,700 | Limestone, pulverized or crushed                    | 1362            | 2,295 |       |             |
| Clay, compact, solid             | 1746 | 2,943 | Sand, damp  | 2083            | 3,510 |       |             |
| Clay, dry in lump loose          | 1009 | 1,701 | Sand, dry   | 1762            | 2,970 |       |             |
| Clay, excavated in water         | 1282 | 2,160 | Sand, voids, full of water                          | 2083            | 3,510 |       |             |
| Coal, anthracite, broken, loose  | 865  | 1,458 | Sandstone, quarried                                 | 1314            | 2,214 |       |             |
| Coal, bituminous, moderately wet | 801  | 1,350 | Shale, broken crushed                               | 1362            | 2,295 |       |             |
| Earth, common loam, dry          | 1218 | 2,052 | Slag, furnace granulated                            | 1955            | 3,294 |       |             |
| Earth, mud, packed               | 1843 | 3,105 | Stone or gravel, 37.5 to 87.5-mm (1.5 to 3.5") size | 1442            | 2,430 |       |             |
| Granite, broken                  | 1538 | 2,592 | Stone or gravel, 18.75-mm (3/4") size               | 1602            | 2,700 |       |             |
| Gypsum                           | 2275 | 3,834 |   |                 |       |       |             |

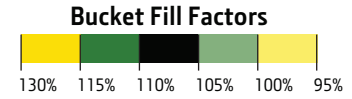

# 724K

| <b>Engine</b>   |  | <b>724K Z-BAR / HIGH-LIFT</b>                                       |   |   |
|---|--|---|---|---|
| Manufacturer and Model  | John Deere PowerTech™ PSX 6090   | John Deere PowerTech™ Plus 6090H                                    | John Deere PowerTech™ 6090H   | John Deere PowerTech™ 6090H   |
| Non-Road Emission Standard  | EPA Final Tier 4/EU Stage IV   | EPA Tier 3/EU Stage IIIA  | EPA Tier 2/EU Stage II  | EPA Tier 2/EU Stage II  |
| Cylinders   | 6  | 6   | 6   | 6   |
| Valves Per Cylinder   | 4  | 4   | 4   | 4   |
| Displacement  | 9.0 L (548 cu. in.)  | 9.0 L (548 cu. in.)   | 9.0 L (548 cu. in.)   | 9.0 L (548 cu. in.)   |
| Net Peak Power (ISO 9249)   | 197 kW (264 hp) at 1,800 rpm   | 197 kW (264 hp) at 1,800 rpm  | 197 kW (264 hp) at 1,800 rpm  | 197 kW (264 hp) at 1,800 rpm  |
| Net Peak Torque (ISO 9249)  | 1161 Nm (856 lb.-ft.) at 1,300 rpm   | 1159 Nm (852 lb.-ft.) at 1,300 rpm                                  | 1159 Nm (852 lb.-ft.) at 1,300 rpm                                  | 1159 Nm (852 lb.-ft.) at 1,300 rpm                                  |
| Net Torque Rise   | 61%  | 60%   | 60%   | 60%   |
| Fuel System (electronically controlled)                               | High-pressure common rail  | High-pressure common rail   | High-pressure common rail   | High-pressure common rail   |
| Lubrication   | Full-flow spin-on filter and integral cooler   | Full-flow spin-on filter and integral cooler                        | Full-flow spin-on filter and integral cooler                        | Full-flow spin-on filter and integral cooler                        |
| Aspiration  | Series turbocharged, charge air cooled   | Turbocharged, charge air cooled                                     | Turbocharged, charge air cooled                                     | Turbocharged, charge air cooled                                     |
| Air Cleaner   | Under-hood, dual-element dry type, restriction indicator in cab monitor for service  |   |   |   |
| Fan Drive   | Hydraulically driven, proportionally controlled, fan aft of coolers  | Hydraulically driven, proportionally controlled, fan aft of coolers | Hydraulically driven, proportionally controlled, fan aft of coolers | Hydraulically driven, proportionally controlled, fan aft of coolers |
| Electrical System   | 24 volt with 130-amp alternator  | 24 volt with 100-amp alternator                                     | 24 volt with 100-amp alternator                                     | 24 volt with 100-amp alternator                                     |
| Batteries (2 – 12 volt)   | 950 CCA (each)   | 1,400 CCA (each)  | 1,400 CCA (each)  | 1,400 CCA (each)  |
| <b>Transmission System</b>  |  |   |   |   |
| Type  | Countershaft-type PowerShift™  |   |   |   |
| Torque Converter  | Single stage, single phase   |   |   |   |
| Shift Control   | Electronically modulated, adaptive, load and speed dependent   |   |   |   |
| Operator Interface  | Steering-column or joystick-mounted F-N-R and gear-select lever; Quick-Shift button on hydraulic lever   |   |   |   |
| Shift Modes   | Manual/auto (1st–D or 2nd–D); Quick-Shift button with 2 selectable modes: kick-down or kick-up/down; and 3 adjustable clutch-cutoff settings           |   |   |   |
|   | <i>Standard 5-Speed with Lockup Torque Converter</i>   |   | <i>Optional 4-Speed</i>   |   |
| Maximum Travel Speeds (with 23.5 R 25, 1 Star L3 tires)               | <i>Forward</i>   | <i>Reverse</i>  | <i>Forward</i>  | <i>Reverse</i>  |
| Range 1   | 7.5 km/h (4.7 mph)   | 7.9 km/h (4.9 mph)  | 7.2 km/h (4.5 mph)  | 7.6 km/h (4.7 mph)  |
| Range 2   | 13.4 km/h (8.3 mph)  | 13.0 km/h (8.1 mph)   | 11.9 km/h (7.4 mph)   | 12.5 km/h (7.8 mph)   |
| Range 3   | 22.6 km/h (14.0 mph)   | 28.8 km/h (17.9 mph)  | 23.1 km/h (14.4 mph)  | 24.2 km/h (15.1 mph)  |
| Range 4   | 27.4 km/h (17.0 mph)   | N/A   | 35.6 km/h (22.1 mph)  | N/A   |
| Range 5   | 40.0 km/h (24.9 mph)   | N/A   | N/A   | N/A   |
| <b>Axles/Brakes</b>   |  |   |   |   |
| Final Drives  | Heavy-duty inboard-mounted planetary   |   |   |   |
| Differentials   | Hydraulic locking front with conventional rear – standard; dual locking front and rear – optional  |   |   |   |
| Rear Axle Oscillation, Stop to Stop (with 23.5 R 25, 1 Star L3 tires) | 26 deg. (13 deg. each direction)   |   |   |   |
| Service Brakes (conform to ISO 3450)                                  | Hydraulically actuated, spring-retracted, self-adjusting, inboard sun-shaft mounted, oil-cooled, single disc   |   |   |   |
| Parking Brakes (conform to ISO 3450)                                  | Automatic spring-applied, hydraulically released, oil-cooled, multi disc   |   |   |   |
| <b>Tires/Wheels (see page 34 for complete tire adjustments)</b>       |  |   |   |   |
|   | <i>Tread Width</i>   | <i>Width Over Tires</i>   |   |   |
| Michelin 23.5 R 25, 1 Star L-3  | 2170 mm (85.4 in.)   | 2880 mm (113.4 in.)   |   |   |
| <b>Serviceability</b>   |  |   |   |   |
| Refill Capacities   | EPA FT4/EU Stage IV  | EPA Tier 3/EU Stage IIIA  | EPA Tier 2/EU Stage II  | EPA Tier 2/EU Stage II  |
| Fuel Tank with Lockable Cap   | 397 L (105 gal.)   | 352 L (93 gal.)   | 352 L (93 gal.)   | 352 L (93 gal.)   |
| Diesel Exhaust Fluid (DEF)  | 32 L (34 qt.)  | N/A   | N/A   | N/A   |
| Cooling System  | 45.5 L (48.1 qt.)  | 33.8 L (35.7 qt.)   | 33.8 L (35.7 qt.)   | 33.8 L (35.7 qt.)   |
| Engine Oil with Vertical Spin-On Filter                               | 28 L (29.5 qt.)  | 29.6 L (28 qt.)   | 29.6 L (28 qt.)   | 29.6 L (28 qt.)   |
| Transmission Reservoir with Vertical Filter                           | 24 L (25 qt.)  | 24 L (25 qt.)   | 24 L (25 qt.)   | 24 L (25 qt.)   |
| Axle Oil (front and rear, each)                                       | 22 L (23 qt.)  | 22 L (23 qt.)   | 22 L (23 qt.)   | 22 L (23 qt.)   |
| Hydraulic Reservoir and Filter  | 105.2 L (27.8 gal.)  | 110 L (29 gal.)   | 110 L (29 gal.)   | 110 L (29 gal.)   |
| Park Brake Oil (wet disc)   | 0.6 L (20 oz.)   | 0.6 L (20 oz.)  | 0.6 L (20 oz.)  | 0.6 L (20 oz.)  |
| <b>Hydraulic System/Steering</b>                                      |  |   |   |   |
| Pump (loader and steering)  | Variable-displacement, axial-piston pump; closed-center, pressure-compensating system  |   |   |   |
| Maximum Rated Flow at 6895 kPa (1,000 psi) and 2,250 rpm              | 297 L/m (78 gpm)   |   |   |   |
| System Relief Pressure (loader and steering)                          | 25 166 kPa (3,650 psi)   |   |   |   |
| Loader Controls   | 2-function valve; joystick control or fingertip controls; hydraulic-function enable/disable; optional 3rd- and 4th-function valve with auxiliary lever |   |   |   |
| Steering (conforms to ISO 5010)                                       |  |   |   |   |
| Type  | Power, fully hydraulic   |   |   |   |
| Articulation Angle  | 80-deg. arc (40 deg. each direction)   |   |   |   |



**Hydraulic System/Steering (continued) 724K Z-BAR / HIGH-LIFT**

|   |                       |           |
|---|-----------------------|-----------|
| Turning Radius (measured to centerline of outside tire) | 5.64 m (18 ft. 6 in.) |           |
| Hydraulic Cycle Times                                   | Z-Bar                 | High-Lift |
| Raise   | 6.4 sec.              | 6.4 sec.  |
| Dump  | 1.4 sec.              | 1.6 sec.  |
| Lower (float down)                                      | 3.0 sec.              | 3.0 sec.  |
| Total   | 10.8 sec.             | 11.0 sec. |

**Dimensions and Specifications with Pin-On Bucket**

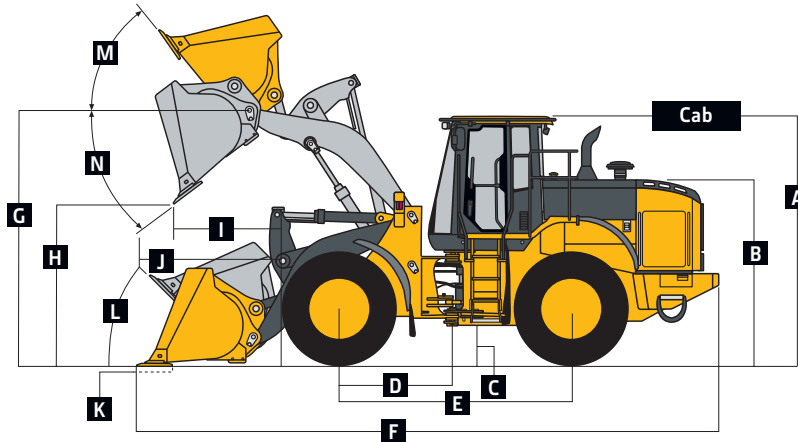

**724K Z-BAR AND HIGH-LIFT LOADERS WITH PIN-ON BUCKET**

|   | Z-Bar   | Z-Bar   | High-Lift   | High-Lift   |
|---|---|---|---|---|
| <b>Dimensions with Bucket</b>   | 3.2-m <sup>3</sup> (4.25 cu. yd.)<br><i>general-purpose with bolt-on edge</i> | 3.6-m <sup>3</sup> (4.75 cu. yd.)<br><i>general-purpose with bolt-on edge</i> | 3.2-m <sup>3</sup> (4.25 cu. yd.)<br><i>general-purpose with bolt-on edge</i> | 3.6-m <sup>3</sup> (4.75 cu. yd.)<br><i>general-purpose with bolt-on edge</i> |
| A Height to Top of Cab  | 3.43 m (11 ft. 3 in.)   | 3.43 m (11 ft. 3 in.)   | 3.43 m (11 ft. 3 in.)   | 3.43 m (11 ft. 3 in.)   |
| B Hood Height   | 2.53 m (8 ft. 4 in.)  | 2.53 m (8 ft. 4 in.)  | 2.53 m (8 ft. 4 in.)  | 2.53 m (8 ft. 4 in.)  |
| C Ground Clearance  | 461 mm (18.1 in.)   | 461 mm (18.1 in.)   | 461 mm (18.1 in.)   | 461 mm (18.1 in.)   |
| D Length from Centerline to Front Axle  | 1.60 m (5 ft. 3 in.)  | 1.60 m (5 ft. 3 in.)  | 1.60 m (5 ft. 3 in.)  | 1.60 m (5 ft. 3 in.)  |
| E Wheelbase   | 3.26 m (10 ft. 8 in.)   | 3.26 m (10 ft. 8 in.)   | 3.26 m (10 ft. 8 in.)   | 3.26 m (10 ft. 8 in.)   |
| F Overall Length, Bucket on Ground  | 8.20 m (26 ft. 11 in.)  | 8.31 m (27 ft. 3 in.)   | 8.67 m (28 ft. 5 in.)   | 8.78 m (28 ft. 10 in.)  |
| G Height to Hinge Pin, Fully Raised   | 4.12 m (13 ft. 6 in.)   | 4.12 m (13 ft. 6 in.)   | 4.54 m (14 ft. 11 in.)  | 4.54 m (14 ft. 11 in.)  |
| H Dump Clearance, 45 deg., Full Height  | 2.91 m (9 ft. 7 in.)  | 2.84 m (9 ft. 4 in.)  | 3.33 m (10 ft. 11 in.)  | 3.26 m (10 ft. 8 in.)   |
| I Reach, 45-deg. Dump, Full Height  | 1.06 m (3 ft. 6 in.)  | 1.13 m (3 ft. 9 in.)  | 1.19 m (3 ft. 11 in.)   | 1.25 m (4 ft. 1 in.)  |
| J Reach, 45-deg. Dump, 2.13-m (7 ft. 0 in.) Clearance   | 1.61 m (5 ft. 3 in.)  | 1.67 m (5 ft. 6 in.)  | 2.06 m (6 ft. 9 in.)  | 2.12 m (6 ft. 11 in.)   |
| K Maximum Digging Depth   | 123 mm (5.0 in.)  | 123 mm (5.0 in.)  | 216 mm (8.5 in.)  | 216 mm (8.5 in.)  |
| L Maximum Rollback at Ground Level  | 41 deg.   | 41 deg.   | 42 deg.   | 42 deg.   |
| M Maximum Rollback, Boom Fully Raised   | 55 deg.   | 55 deg.   | 47 deg.   | 47 deg.   |
| N Maximum Bucket Dump Angle, Fully Raised   | 50 deg.   | 50 deg.   | 45 deg.   | 45 deg.   |
| Loader Clearance Circle, Bucket Carry Position  | 13.19 m (43 ft. 3 in.)  | 13.25 m (43 ft. 6 in.)  | 13.62 m (44 ft. 8 in.)  | 13.68 m (44 ft. 11 in.)   |
| <b>Specifications with Bucket</b>   |   |   |   |   |
| Capacity, Heaped  | 3.2 m <sup>3</sup> (4.25 cu. yd.)   | 3.6 m <sup>3</sup> (4.75 cu. yd.)   | 3.2 m <sup>3</sup> (4.25 cu. yd.)   | 3.6 m <sup>3</sup> (4.75 cu. yd.)   |
| Capacity, Struck  | 3.0 m <sup>3</sup> (3.5 cu. yd.)  | 3.2 m <sup>3</sup> (4.2 cu. yd.)  | 2.8 m <sup>3</sup> (3.7 cu. yd.)  | 3.2 m <sup>3</sup> (4.2 cu. yd.)  |
| Bucket Weight with Bolt-On Cutting Edge   | 1736 kg (3,827 lb.)   | 1822 kg (4,016 lb.)   | 1736 kg (3,827 lb.)   | 1822 kg (4,017 lb.)   |
| Bucket Width  | 3.04 m (10 ft. 0 in.)   | 3.04 m (10 ft. 0 in.)   | 3.04 m (10 ft. 0 in.)   | 3.04 m (10 ft. 0 in.)   |
| Breakout Force  | 15 607 kg (34,408 lb.)  | 14 398 kg (31,742 lb.)  | 13 884 kg (30,610 lb.)  | 12 968 kg (28,590 lb.)  |
| Tipping Load, Straight, No Tire Deflection  | 16 508 kg (36,396 lb.)  | 16 236 kg (35,794 lb.)  | 13 332 kg (29,393 lb.)  | 13 101 kg (28,883 lb.)  |
| Tipping Load, Straight, With Tire Deflection  | 15 534 kg (34,247 lb.)  | 15 267 kg (33,658 lb.)  | 12 645 kg (27,877 lb.)  | 12 420 kg (27,381 lb.)  |
| Tipping Load, 40-deg. Full Turn, No Tire Deflection   | 14 266 kg (31,451 lb.)  | 14 015 kg (30,899 lb.)  | 11 466 kg (25,278 lb.)  | 11 252 kg (24,806 lb.)  |
| Tipping Load, 40-deg. Full Turn, With Tire Deflection   | 13 047 kg (28,764 lb.)  | 12 801 kg (28,221 lb.)  | 10 578 kg (23,320 lb.)  | 10 371 kg (22,864 lb.)  |
| Rated Operating Load, 50% Full-Turn Tipping Load, No Tire Deflection (conforms to ISO 14397-1)*   | 7133 kg (15,726 lb.)  | 7008 kg (15,449 lb.)  | 5733 kg (12,639 lb.)  | 5626 kg (12,403 lb.)  |
| Rated Operating Load, 50% Full-Turn Tipping Load, With Tire Deflection (conforms to ISO 14397-1)* | 6524 kg (14,383 lb.)  | 6401 kg (14,111 lb.)  | 5289 kg (11,660 lb.)  | 5186 kg (11,433 lb.)  |
| Operating Weight  | 19 419 kg (42,812 lb.)  | 19 512 kg (43,016 lb.)  | 19 646 kg (43,311 lb.)  | 19 739 kg (43,516 lb.)  |

Loader operating information is based on machine with identified linkage and standard equipment, PowerTech PSX 6090 (EPA Final Tier 4/EU Stage IV) engine, ROPS cab, rear cast bumper/counterweight, transmission side-frame guards, bottom guards, standard tires, full fuel tank, and 79-kg (175 lb.) operator. This information is affected by changes in tires, ballast, and different attachments.

\*Rated operating capacity based on Deere attachments only.

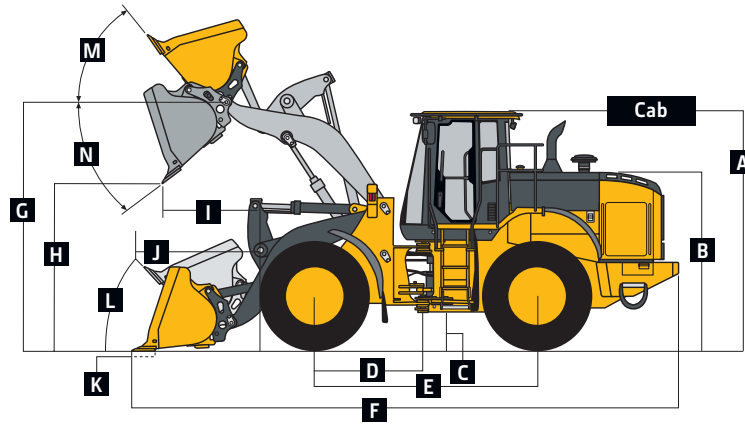

724K Z-BAR AND HIGH-LIFT LOADERS WITH QUICK-COUPLER AND HOOK-ON BUCKET

|   | Z-Bar  | High-Lift  |
|---|--|--|
| <b>Dimensions with Bucket</b>   | <i>3.1-m<sup>3</sup> (4.0 cu. yd.) general-purpose with bolt-on edge</i> | <i>3.1-m<sup>3</sup> (4.0 cu. yd.) general-purpose with bolt-on edge</i> |
| A Height to Top of Cab  | 3.43 m (11 ft. 3 in.)  | 3.43 m (11 ft. 3 in.)  |
| B Hood Height   | 2.53 m (8 ft. 4 in.)   | 2.53 m (8 ft. 4 in.)   |
| C Ground Clearance  | 461 mm (18.1 in.)  | 461 mm (18.1 in.)  |
| D Length from Centerline to Front Axle  | 1.60 m (5 ft. 3 in.)   | 1.60 m (5 ft. 3 in.)   |
| E Wheelbase   | 3.26 m (10 ft. 8 in.)  | 3.26 m (10 ft. 8 in.)  |
| F Overall Length, Bucket on Ground  | 8.20 m (26 ft. 11 in.)   | 8.74 m (28 ft. 8 in.)  |
| G Height to Hinge Pin, Fully Raised   | 4.12 m (13 ft. 6 in.)  | 4.54 m (14 ft. 11 in.)   |
| H Dump Clearance, 45 deg., Full Height  | 2.88 m (9 ft. 6 in.)   | 3.11 m (10 ft. 2 in.)  |
| I Reach, 45-deg. Dump, Full Height  | 1.15 m (3 ft. 9 in.)   | 1.28 m (4 ft. 2 in.)   |
| J Reach, 45-deg. Dump, 2.13-m (7 ft. 0 in.) Clearance   | 1.72 m (5 ft. 8 in.)   | 2.10 m (6 ft. 11 in.)  |
| K Maximum Digging Depth   | 123 mm (5.0 in.)   | 216 mm (8.5 in.)   |
| L Maximum Rollback at Ground Level  | 41 deg.  | 42 deg.  |
| M Maximum Rollback, Boom Fully Raised   | 55 deg.  | 47 deg.  |
| N Maximum Bucket Dump Angle, Fully Raised   | 50 deg.  | 45 deg.  |
| Loader Clearance Circle, Bucket Carry Position  | 12.93 m (42 ft. 5 in.)   | 13.72 m (45 ft. 0 in.)   |
| <b>Specifications with Bucket</b>   |  |  |
| Capacity, Heaped  | 3.1 m <sup>3</sup> (4.0 cu. yd.)   | 3.1 m <sup>3</sup> (4.0 cu. yd.)   |
| Capacity, Struck  | 2.4 m <sup>3</sup> (3.2 cu. yd.)   | 2.4 m <sup>3</sup> (3.2 cu. yd.)   |
| Bucket Weight with Bolt-On Cutting Edge   | 1764 kg (3,890 lb.)  | 1764 kg (3,890 lb.)  |
| Bucket Width  | 2.90 m (9 ft. 6 in.)   | 2.90 m (9 ft. 6 in.)   |
| Breakout Force  | 14 524 kg (32,019 lb.)   | 12 404 kg (27,346 lb.)   |
| Tipping Load, Straight, No Tire Deflection  | 15 025 kg (33,125 lb.)   | 12 178 kg (26,848 lb.)   |
| Tipping Load, Straight, With Tire Deflection  | 14 157 kg (31,211 lb.)   | 11 553 kg (25,470 lb.)   |
| Tipping Load, 40-deg. Full Turn, No Tire Deflection   | 12 929 kg (28,503 lb.)   | 10 416 kg (22,964 lb.)   |
| Tipping Load, 40-deg. Full Turn, With Tire Deflection   | 11 829 kg (26,078 lb.)   | 9603 kg (21,171 lb.)   |
| Rated Operating Load, 50% Full-Turn Tipping Load, No Tire Deflection (conforms to ISO 14397-1)*   | 6464 kg (14,251 lb.)   | 5208 kg (11,482 lb.)   |
| Rated Operating Load, 50% Full-Turn Tipping Load, With Tire Deflection (conforms to ISO 14397-1)* | 5915 kg (13,040 lb.)   | 4802 kg (10,586 lb.)   |
| Operating Weight  | 19 810 kg (43,674 lb.)   | 20 037 kg (44,173 lb.)   |

Loader operating information is based on machine with identified linkage and standard equipment, PowerTech PSX 6090 (EPA Final Tier 4/EU Stage IV) engine, ROPS cab, rear cast bumper/counterweight, transmission side-frame guards, bottom guards, standard tires, full fuel tank, and 79-kg (175 lb.) operator. This information is affected by changes in tires, ballast, and different attachments.

\*Rated operating capacity based on Deere attachments only.



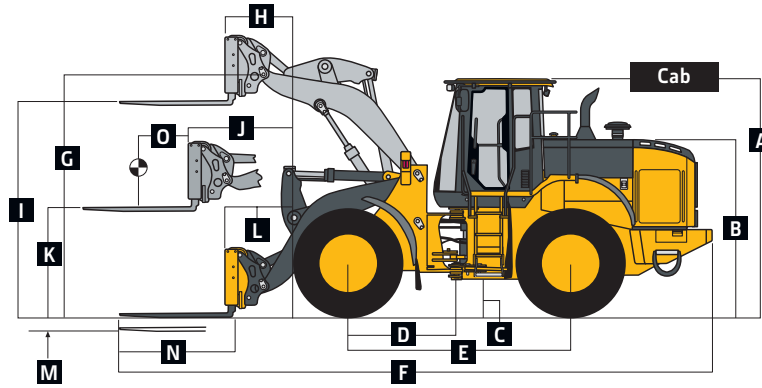

724K Z-BAR AND HIGH-LIFT LOADERS WITH QUICK-COUPLER AND HOOK-ON CONSTRUCTION FORKS

|  | Z-Bar<br>1.52-m (60 in.) tine length | Z-Bar<br>1.83-m (72 in.) tine length | High-Lift<br>1.52-m (60 in.) tine length | High-Lift<br>1.83-m (72 in.) tine length |
|--|--------------------------------------|--------------------------------------|--|--|
| <b>Dimensions with Forks</b>   |                                      |                                      |  |  |
| <b>A</b> Height to Top of Cab  | 3.43 m (11 ft. 3 in.)                | 3.43 m (11 ft. 3 in.)                | 3.43 m (11 ft. 3 in.)                    | 3.43 m (11 ft. 3 in.)                    |
| <b>B</b> Hood Height   | 2.53 m (8 ft. 4 in.)                 | 2.53 m (8 ft. 4 in.)                 | 2.53 m (8 ft. 4 in.)                     | 2.53 m (8 ft. 4 in.)                     |
| <b>C</b> Ground Clearance  | 461 mm (18.1 in.)                    | 461 mm (18.1 in.)                    | 461 mm (18.1 in.)                        | 461 mm (18.1 in.)                        |
| <b>D</b> Length from Centerline to Front Axle  | 1.60 m (5 ft. 3 in.)                 | 1.60 m (5 ft. 3 in.)                 | 1.60 m (5 ft. 3 in.)                     | 1.60 m (5 ft. 3 in.)                     |
| <b>E</b> Wheelbase   | 3.26 m (10 ft. 8 in.)                | 3.26 m (10 ft. 8 in.)                | 3.26 m (10 ft. 8 in.)                    | 3.26 m (10 ft. 8 in.)                    |
| <b>F</b> Overall Length, Forks on Ground   | 8.89 m (29 ft. 2 in.)                | 9.19 m (30 ft. 2 in.)                | 9.35 m (30 ft. 8 in.)                    | 9.65 m (31 ft. 8 in.)                    |
| <b>G</b> Height to Hinge Pin, Fully Raised   | 4.12 m (13 ft. 6 in.)                | 4.12 m (13 ft. 6 in.)                | 4.54 m (14 ft. 11 in.)                   | 4.54 m (14 ft. 11 in.)                   |
| <b>H</b> Reach, Fully Raised   | 788 mm (31.0 in.)                    | 788 mm (31.0 in.)                    | 905 mm (35.6 in.)                        | 905 mm (35.6 in.)                        |
| <b>I</b> Fork Height, Fully Raised   | 3.89 m (12 ft. 9.0 in.)              | 3.89 m (12 ft. 9.0 in.)              | 4.22 m (13 ft. 10.1 in.)                 | 4.22 m (13 ft. 10.1 in.)                 |
| <b>J</b> Maximum Reach, Fork Level   | 1.68 m (5 ft. 6.0 in.)               | 1.68 m (5 ft. 6.0 in.)               | 2.07 m (6 ft. 9.5 in.)                   | 2.07 m (6 ft. 9.5 in.)                   |
| <b>K</b> Fork Height, Maximum Reach  | 1.71 m (5 ft. 7.0 in.)               | 1.71 m (5 ft. 7.0 in.)               | 1.86 m (6 ft. 1.2 in.)                   | 1.86 m (6 ft. 1.2 in.)                   |
| <b>L</b> Reach, Ground Level   | 1.17 m (3 ft. 10.0 in.)              | 1.17 m (3 ft. 10.0 in.)              | 1.64 m (5 ft. 4.6 in.)                   | 1.64 m (5 ft. 4.6 in.)                   |
| <b>M</b> Depth Below Ground  | 89 mm (4.0 in.)                      | 89 mm (4.0 in.)                      | 181 mm (7.1 in.)                         | 181 mm (7.1 in.)                         |
| <b>N</b> Tine Length   | 1.52 m (60 in.)                      | 1.83 m (72 in.)                      | 1.52 m (60 in.)                          | 1.83 m (72 in.)                          |
| <b>O</b> Load Position, 50% Tine Length  | 0.76 m (30 in.)                      | 0.92 m (36 in.)                      | 0.76 m (30 in.)                          | 0.92 m (36 in.)                          |
| <b>Specifications with Forks</b>   |                                      |                                      |  |  |
| Tipping Load, Straight, No Tire Deflection   | 11 082 kg (24,432 lb.)               | 10 518 kg (23,188 lb.)               | 9598 kg (21,160 lb.)                     | 9143 kg (20,156 lb.)                     |
| Tipping Load, Straight, With Tire Deflection   | 10 770 kg (23,744 lb.)               | 10 227 kg (22,547 lb.)               | 9342 kg (20,596 lb.)                     | 8904 kg (19,630 lb.)                     |
| Tipping Load, 40-deg. Full Turn, No Tire Deflection  | 9576 kg (21,112 lb.)                 | 9080 kg (20,017 lb.)                 | 8256 kg (18,202 lb.)                     | 7855 kg (17,317 lb.)                     |
| Tipping Load, 40-deg. Full Turn, With Tire Deflection  | 9162 kg (20,199 lb.)                 | 9691 kg (21,365 lb.)                 | 7911 kg (17,441 lb.)                     | 7530 kg (16,601 lb.)                     |
| Rated Operating Load, 50% Full-Turn Tipping Load, With Tire Deflection (conforms to ISO 14397-1 and SAE J1197)*      | 4581 kg (10,099 lb.)                 | 4846 kg (10,684 lb.)                 | 3956 kg (8,721 lb.)                      | 3765 kg (8,300 lb.)                      |
| Rated Operating Load, Rough Terrain, 60% Full-Turn Tipping Load, With Tire Deflection (conforms to EN474-3)*         | 5497 kg (12,119 lb.)                 | 5815 kg (12,820 lb.)                 | 4747 kg (10,465 lb.)                     | 4518 kg (9,960 lb.)                      |
| Rated Operating Load, Firm and Level Ground, 80% Full-Turn Tipping Load, With Tire Deflection (conforms to EN474-3)* | 7330 kg (16,160 lb.)                 | 7753 kg (17,092 lb.)                 | 6329 kg (13,953 lb.)                     | 6024 kg (13,281 lb.)                     |
| Operating Weight   | 19 385 kg (42,738 lb.)               | 19 446 kg (42,870 lb.)               | 19 618 kg (43,250 lb.)                   | 19 678 kg (43,383 lb.)                   |

Loader operating information is based on machine with identified linkage and standard equipment, PowerTech PSX 6090 (EPA Final Tier 4/EU Stage IV) engine, ROPS cab, rear cast bumper/counterweight, transmission side-frame guards, bottom guards, standard tires, full fuel tank, and 79-kg (175 lb.) operator. This information is affected by changes in tires, ballast, and different attachments.

\*Rated operating capacity based on Deere attachments only.

**Adjustments to Operating Weights and Tipping Loads with Buckets**

**724K Z-BAR / HIGH-LIFT**

Adjustments to operating weights, tipping loads, and tires are based on Z-bar machine with pin-on 3.6-m<sup>3</sup> (4.75 cu. yd.) general-purpose bucket with bolt-on cutting edge, ROPS cab, rear cast bumper/counterweight, transmission side-frame guards, bottom guards, standard tires, full fuel tank, and 79-kg (175 lb.) operator\*

| Add (+) or deduct (-) kg (lb.) as indicated for loaders with 3-piece rims | Operating Weight     | Tipping Load, Straight | Tipping Load, 40-deg. Full Turn SAE | Tread Width       | Width Over Tires   | Vertical Height   |
|---|----------------------|------------------------|-------------------------------------|-------------------|--------------------|-------------------|
| John Deere PowerTech PSX 6090   | 0 kg (0 lb.)         | 0 kg (0 lb.)           | 0 kg (0 lb.)                        | N/A               | N/A                | N/A               |
| John Deere PowerTech Plus 6090H   | -120 kg (-265 lb.)   | +44 kg (+97 lb.)       | +13 kg (+29 lb.)                    | N/A               | N/A                | N/A               |
| John Deere PowerTech 6090H  | -126 kg (-278 lb.)   | +34 kg (+75 lb.)       | +4 kg (+9 lb.)                      | N/A               | N/A                | N/A               |
| Michelin 23.5 R 25, 1 Star L-3  | 0 kg (0 lb.)         | 0 kg (0 lb.)           | 0 kg (0 lb.)                        | 0 mm (0 in.)      | 0 mm (0 in.)       | 0 mm (0 in.)      |
| Bridgestone 23.5 R 25, 1 Star L-3   | +116 kg (+256 lb.)   | +86 kg (+190 lb.)      | +76 kg (+167 lb.)                   | 0 mm (0 in.)      | -28 mm (-1.1 in.)  | +17 mm (+0.7 in.) |
| Titan 23.5-25, 20 PR L-3  | -156 kg (-343 lb.)   | -115 kg (-255 lb.)     | -102 kg (-224 lb.)                  | 0 mm (0 in.)      | +27 mm (+1.1 in.)  | 0 mm (0 in.)      |
| Titan 725/70-25, 16-Ply L-4T (Logger Style) <sup>18</sup>                 | +266 kg (+587 lb.)   | +208 kg (+459 lb.)     | +183 kg (+404 lb.)                  | +37 mm (+1.5 in.) | +95 mm (+3.7 in.)  | +49 mm (+1.9 in.) |
| Michelin 750/65 R 25, 1 Star L-3T <sup>18</sup>                           | +622 kg (+1,371 lb.) | +472 kg (+1,041 lb.)   | +416 kg (+917 lb.)                  | +37 mm (+1.5 in.) | +158 mm (+6.2 in.) | +12 mm (+0.5 in.) |

\*May change based on vehicle configuration, weight, or tire-pressure adjustments.

<sup>1</sup>Equipped with 5-piece heavy-duty rims.

<sup>18</sup>Requires 9-deg. rear axle stops.

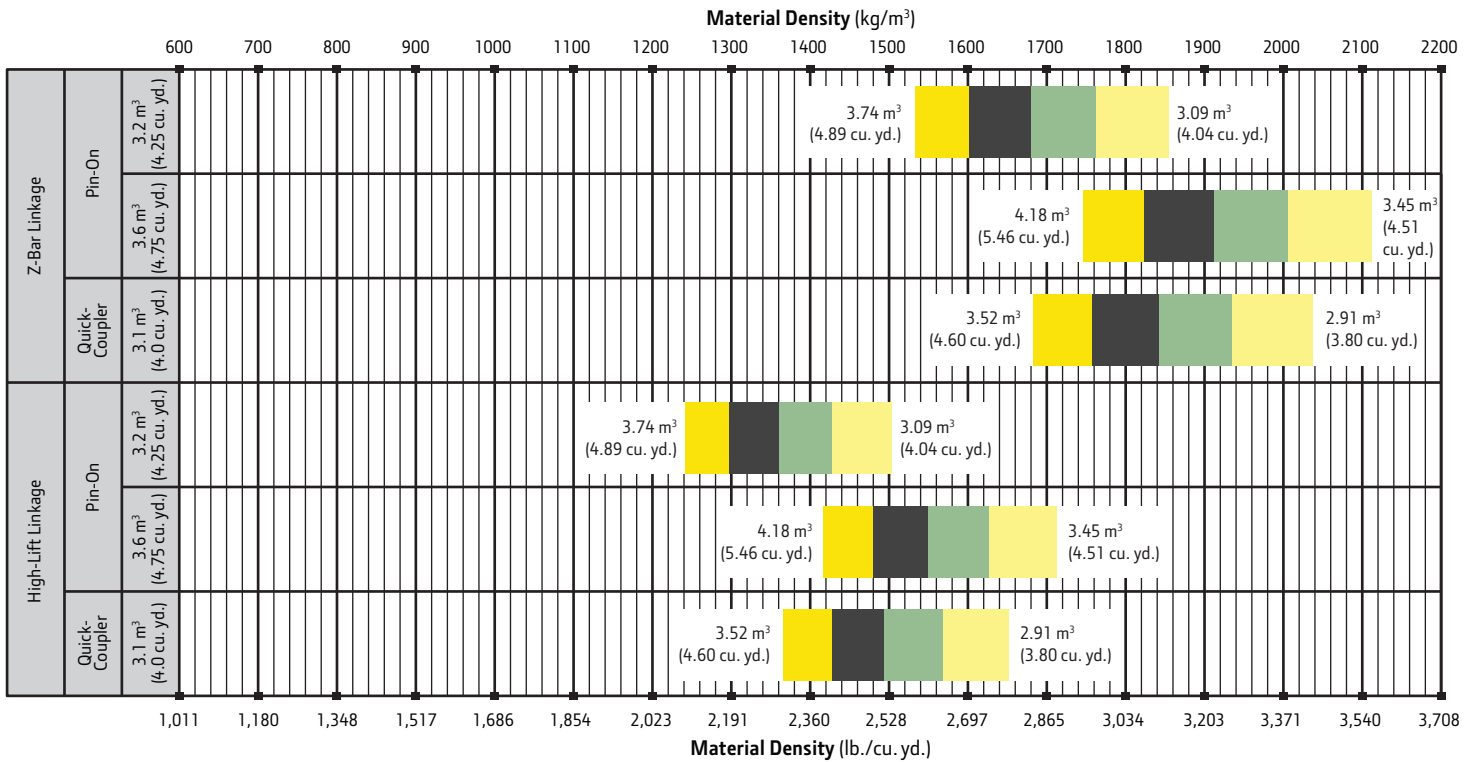

| LOOSE MATERIALS                  | kg/m <sup>3</sup> | lb./cu. yd. | LOOSE MATERIALS                                     | kg/m <sup>3</sup> | lb./cu. yd. |
|----------------------------------|-------------------|-------------|---|-------------------|-------------|
| Chips, pulpwood                  | 288               | 486         | Limestone, coarse, sized                            | 1570              | 2,646       |
| Cinders (coal, ashes, clinkers)  | 673               | 1,134       | Limestone, mixed sizes                              | 1682              | 2,835       |
| Clay and gravel, dry             | 1602              | 2,700       | Limestone, pulverized or crushed                    | 1362              | 2,295       |
| Clay, compact, solid             | 1746              | 2,943       | Sand, damp  | 2083              | 3,510       |
| Clay, dry in lump loose          | 1009              | 1,701       | Sand, dry   | 1762              | 2,970       |
| Clay, excavated in water         | 1282              | 2,160       | Sand, voids, full of water                          | 2083              | 3,510       |
| Coal, anthracite, broken, loose  | 865               | 1,458       | Sandstone, quarried                                 | 1314              | 2,214       |
| Coal, bituminous, moderately wet | 801               | 1,350       | Shale, broken crushed                               | 1362              | 2,295       |
| Earth, common loam, dry          | 1218              | 2,052       | Slag, furnace granulated                            | 1955              | 3,294       |
| Earth, mud, packed               | 1843              | 3,105       | Stone or gravel, 37.5 to 87.5-mm (1.5 to 3.5") size | 1442              | 2,430       |
| Granite, broken                  | 1538              | 2,592       | Stone or gravel, 18.75-mm (3/4") size               | 1602              | 2,700       |
| Gypsum                           | 2275              | 3,834       |   |                   |             |

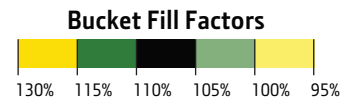

# Additional equipment

Key: ● Standard ▲ Optional or special See your John Deere dealer for further information.

| 624                       | 644 | 724 | Engine   |
|---------------------------|-----|-----|--|
| ●                         | ●   | ●   | Wet-sleeve cylinder liners   |
| ●                         | ●   | ●   | Automatic glow plugs for cold start*   |
| ●                         | ●   | ●   | Programmable auto-idle and auto shutdown   |
| ●                         | ●   | ●   | Selected idle adjustment from 900–1,250 rpm  |
| ●                         | ●   | ●   | Starter protection   |
| ●                         | ●   | ●   | Automatic engine cool-down timer†  |
| ●                         | ●   | ●   | Automatic derating for exceeded system temperatures  |
| ●                         | ●   | ●   | Serpentine drive belt for automatic tensioner  |
| ●                         | ●   | ●   | Under-hood prescreened air intake <sup>§</sup>   |
| ●                         | ●   | ●   | Electrical fuel-priming pump <sup>#</sup>  |
| ●                         | ●   | ●   | Dual-stage fuel filter and water separator   |
| ●                         | ●   | ●   | 500-hour vertical spin-on oil filter   |
| ▲                         | ▲   | ▲   | Engine-compartment light   |
| ▲                         | ▲   | ▲   | Chrome exhaust stack   |
|                           | ▲   | ▲   | Automatic ether starting aid (recommended for cold starts below –12 deg. C [10 deg. F]) <sup>§</sup> |
| ▲                         | ▲   | ▲   | Engine-block heater (recommended for cold starts below –23 deg. C [–10 deg. F])                      |
| ▲                         | ▲   | ▲   | Centrifugal engine air pre-cleaner   |
| Powertrain                |     |     |  |
| ●                         | ●   | ●   | Programmable maximum high gear   |
| ●                         | ●   | ●   | Clutch calibration engaged from monitor  |
| ●                         | ●   | ●   | 2,000-hour vertical spin-on transmission filter  |
| ●                         | ●   | ●   | Transmission fill tube and sight gauge   |
|                           | ●   | ●   | Transmission diagnostic ports  |
| ●                         | ●   | ●   | 5-speed transmission with lockup torque converter  |
| ▲                         | ▲   | ▲   | 4-speed transmission with non-lockup torque converter  |
|                           | ▲   |     | Hybrid-electric transmission system  |
| ●                         | ●   | ●   | Front locking differential   |
| ▲                         | ▲   | ▲   | Rear locking differential  |
| ●                         | ●   | ●   | Brake retractors and adjusters (not available with hybrid-electric transmission-system option)       |
| ▲                         | ▲   | ▲   | Automatic differential lock  |
| ●                         | ●   | ●   | Axle oil temperature sensing   |
| ▲                         | ▲   | ●   | Wheel-spin control   |
| Quad-Cool™ Cooling System |     |     |  |
| ●                         | ●   | ●   | Heavy-duty, trash-resistant radiator and high-ambient cooling package                                |
| ●                         | ●   | ●   | 2-side access to all coolers   |
| ●                         | ●   | ●   | Isolated from engine compartment   |
| ●                         | ●   | ●   | Engine radiator  |
| ●                         | ●   | ●   | Integral engine oil cooler   |
| ●                         | ●   | ●   | Hydraulic oil cooler (oil to air)  |
| ●                         | ●   | ●   | Transmission oil cooler (oil to air)   |
| ●                         | ●   | ●   | Charge air cooler (air to air)   |
| ●                         | ●   | ●   | Fuel cooler <sup>†</sup>   |
| ●                         | ●   | ●   | Coolant recovery tank  |
| ●                         | ●   | ●   | Antifreeze, –37 deg. C [–34 deg. F]  |
| ●                         | ●   | ●   | Cool-on-demand swing-out fan   |
| ●                         | ●   | ●   | Enclosed fan safety guard  |
| ▲                         | ▲   | ▲   | Automatic reversing fan drive  |
| ●                         | ●   | ●   | Axle and service-brake coolers (optional on units equipped with hybrid-electric transmission system) |

| 624  | 644 | 724 | Hydraulics   |
|--|-----|-----|--|
| ●  | ●   | ●   | Automatic return-to-dig bucket positioner  |
| ●  | ●   | ●   | In-cab adjustable automatic return-to-dig bucket positioner (Powerllec™ only)  |
| ●  | ●   | ●   | In-cab adjustable automatic boom-height kickout/return to carry  |
| ●  | ●   | ●   | Reservoir with sight gauge and fill strainer   |
| ●  | ●   | ●   | Hydraulic diagnostic ports   |
| ●  | ●   | ●   | 4,000-hour in-tank filter  |
| ●  | ●   | ▲   | 2 function — joystick with F-N-R   |
| ▲  | ▲   | ▲   | 2 function — joystick with steering column F-N-R   |
| ▲  | ▲   | ●   | 2 function — 2-lever fingertip controls and steering column F-N-R  |
| ▲  | ▲   | ▲   | 3 function — joystick with F-N-R and 3rd-function auxiliary lever  |
| ▲  | ▲   | ▲   | 3 function — joystick with steering column F-N-R and 3rd-function auxiliary lever  |
| ▲  | ▲   | ▲   | 3 function — 3-lever fingertip controls and steering column F-N-R  |
| ▲  | ▲   | ▲   | 4 function — 4-lever fingertip controls and steering column F-N-R  |
| ▲  | ▲   | ●   | Ride control, automatic with monitor-adjustable speed settings   |
| ▲  | ▲   | ▲   | Hydraulic control system for quick-coupler locking pins  |
| ▲  | ▲   | ▲   | Hydrau™ XR cold-temperature hydraulic fluid recommended below –25 deg. C. (–13 deg. F)   |
| Steering Systems   |     |     |  |
| ●  | ●   | ●   | Conventional steering wheel with spinner knob  |
|  | ▲   | ▲   | Joystick steering (including conventional steering column) with gearshift, F-N-R, and horn   |
| ▲  | ▲   | ▲   | Secondary steering   |
| Electrical   |     |     |  |
| ●  | ●   | ●   | Solid-state electrical power-distribution system   |
| ●  | ●   | ●   | Lockable master electrical-disconnect switch   |
| ●  | ●   | ●   | Battery-terminal safety covers   |
| ●  | ●   | ●   | By-pass start safety cover at starter  |
| ●  | ●   | ●   | Remote jump-start access in battery box <sup>†</sup>   |
| ●  | ●   | ●   | Pre-wired for beacon/strobe light  |
| ●  | ●   | ●   | Lights: Halogen driving lights with guards (2) / Front (4) and rear (2) cab work lights / Incandescent front turn signals and flashers / LED stop- and taillights  |
| ▲  | ▲   | ▲   | Heavy-duty front LED turn signal and marker lights   |
| ▲  | ▲   | ▲   | Premium LED work, drive, and marker lights   |
| ●  | ●   | ●   | Programmable courtesy lights   |
| ●  | ●   | ●   | Horn, electric   |
| ●  | ●   | ●   | Reverse warning alarm  |
| ●  | ●   | ●   | Multi-function/multi-language LCD color monitor includes: Digital instruments — Analog display (hydraulic oil temperature, engine coolant temperature, transmission oil temperature, and engine oil pressure) / Digital display (engine rpm, transmission gear/direction indicator, hour meter, fuel level, diesel exhaust fluid (DEF) level <sup>‡</sup> , speedometer, odometer, and average fuel consumption) |
| *Available only on 624K EPA Final Tier 4 (FT4)/EU Stage IV engines, 624K and 644K EPA Tier 3/EU Stage IIIA and EPA Tier 2/EU Stage II engines, and 644K Hybrid EPA Interim Tier 4/EU Stage IIIB engines. |     |     |  |
| †Available only with EPA FT4/EU Stage IV engines.  |     |     |  |
| ‡Available only on 624K and 644K EPA Tier 3/EU Stage IIIA and EPA Tier 2/EU Stage II engines.  |     |     |  |
| §Available only on 624K, 644K, and 724K EPA FT4/EU Stage IV engines, and 724K EPA Tier 3/EU Stage IIIA and EPA Tier 2/EU Stage II engines.   |     |     |  |
| ¶Available only on 644K and 724K EPA FT4/EU Stage IV engines, and 724K EPA Tier 3/EU Stage IIIA and EPA Tier 2/EU Stage II engines.  |     |     |  |

Net engine power is with standard equipment including air cleaner, exhaust system, alternator, and cooling fan at test conditions per ISO 9249. No derating is required up to 3050-m (10,000 ft.) altitude. Specifications and design subject to change without notice. Specifications with the exception of bucket capacity are in accordance with all applicable ISO standards. Except where otherwise noted, these specifications are based on units with applicable linkage and standard equipment, ROPS cab, rear cast bumper/counterweight, transmission side-frame guards, bottom guards, standard tires, full fuel tank, and 79-kg (175 lb.) operator.

# Additional equipment *(continued)*

Key: ● Standard ▲ Optional or special See your John Deere dealer for further information.

## 624 644 724 Electrical *(continued)*

|       |  |
|-------|--|
| ● ● ● | Integrated cycle counter with 5 categories   |
| ● ● ● | Indicator lights: Standard and selected options / Amber caution and red stop                                 |
| ● ● ● | Operator-warning messages  |
| ● ● ● | Built-in diagnostics: Diagnostic-code details / Sensor values / Calibrations / Individual circuit tester     |
| ▲ ▲ ▲ | Electrical corrosion-prevention package  |
| ▲ ▲ ▲ | AM/FM/Weather-Band (WB) radio with remote auxiliary port   |
| ▲ ▲ ▲ | Premium AM/FM/WB/XM Satellite Radio™ ready radio with Bluetooth®, remote auxiliary port, and remote USB port |
| ● ● ● | 24- to 12-volt, 8-amp converter and power port   |
| ▲ ▲ ▲ | 24- to 12-volt, 15- or 30-amp converter and power port   |

## Operator's Station

|       |  |
|-------|--|
| ▲ ▲   | Quiet Cab with heater (ROPS/FOPS Level 1, isolation mounted)   |
| ● ● ● | Quiet Cab with air conditioning/heater (ROPS/FOPS Level 1, isolation mounted)  |
| ● ● ● | Keyless start with multiple security modes   |
| ● ● ● | Sealed-switch module with function indicators  |
| ● ● ● | Seat with backrest extension, deep foam, fabric cover, and adjustable air suspension                                 |
| ▲ ▲   | Seat with backrest extension, deep foam, vinyl cover, and adjustable air suspension                                  |
| ▲ ▲ ▲ | Premium seat with high-wide back and headrest extension, heated, leather/fabric cover, and adjustable air suspension |
| ● ● ● | Hydraulic controls integrated to seat  |
| ● ● ● | High-visibility, bright-orange seat belt, 76 mm (3 in.), with retractor  |
| ● ● ● | Cup holders (2)  |
| ● ● ● | Lunch-box/cooler holder  |
| ● ● ● | Dome and reading light (included with Quiet Cab)   |
| ● ● ● | Rubber floor mat   |
| ● ● ● | Tilt steering column   |
| ● ● ● | Operator's manual storage compartment  |
| ● ● ● | Outside (2) and inside (1) rearview mirrors  |
| ▲ ▲ ▲ | Large heated outside mirrors   |
| ● ● ● | Left-side operator-station access  |
| ● ● ● | Slip-resistant steps and ergonomic handholds   |
| ● ● ● | Sun visor (Quiet Cab only)   |
| ● ● ● | Radio ready (Quiet Cab only)   |
| ● ● ● | Front and rear intermittent windshield wiper and washers   |
| ▲ ▲ ▲ | Powered cab air pre-cleaner  |
| ▲ ▲ ▲ | Beacon bracket (single or dual available)  |
| ▲ ▲ ▲ | Rearview camera  |
| ▲ ▲ ▲ | Rearview camera and radar object-detection system  |
| ● ● ● | LOADRITE™ L2180™ Payload Scale Ready   |
| ▲ ▲ ▲ | LOADRITE L2180 Payload Scale   |
| ▲ ▲ ▲ | Embedded payload scale   |
| ▲ ▲ ▲ | Fire extinguisher  |

## Loader Linkage

|       |  |
|-------|--|
| ● ● ● | Z-bar loader linkage                               |
| ▲ ▲ ▲ | High-Lift Z-bar loader linkage                     |
| ▲ ▲   | Powerllec linkage for visibility and parallel-lift |
| ▲     | Tool-carrier linkage for parallel-lift             |

## 624 644 724 Buckets and Attachments

|       |  |
|-------|--|
| ▲ ▲ ▲ | Full line of Deere pin-on buckets                                      |
| ▲     | Worksite Pro™ hydraulic coupler that accepts JRB-pattern attachments   |
| ▲ ▲ ▲ | Hi-Vis hydraulic coupler that accepts Euro-pattern attachments (Volvo) |
| ▲ ▲ ▲ | Full line of Deere hook-on buckets and forks                           |
| ▲ ▲ ▲ | Bolt-on fork frame guard   |

## Overall Vehicle

|       |  |
|-------|--|
| ● ● ● | JDLink™ Ultimate wireless communication system (available in specific countries; see your dealer for details)  |
| ● ● ● | NeverGrease™ rear-axle oscillation   |
| ● ● ● | NeverGrease steering-cylinder joints   |
| ● ● ● | Front and rear tie-downs   |
| ● ● ● | Rear cast bumper/counterweight with rear hitch and locking pin   |
| ● ● ● | Articulation locking bar   |
| ● ● ● | Loader boom service locking bar  |
| ● ● ● | 40-deg. steering articulation to each side with rubber-cushion stops on frame  |
| ● ● ● | Vandal protection with lockable engine enclosures, right counterweight storage, and filler access for radiator/fuel/DEF <sup>1</sup> /hydraulic transmission |
|       | ● Right and left platforms with handrails  |
| ● ● ● | Left-side service steps and handholds  |
| ▲ ▲ ▲ | Right-side service steps and handholds   |
| ▲ ▲   | Left-side close-mounted steps <sup>§</sup>   |
| ● ● ● | Storage compartment  |
| ● ● ● | Fuel-tank fill strainer  |
| ● ● ● | Heavy-duty fuel-tank guard   |
| ● ● ● | Ground-level fueling and DEF <sup>1</sup>  |
| ● ● ● | Same-side ground-level daily servicing   |
| ▲ ● ● | Environmental drains for engine, transmission, hydraulic oils, and engine coolant  |
| ▲ ▲ ▲ | Quick fluid service (engine, transmission, hydraulic oils, and engine coolant)   |
| ●     | 20.5R25 tires on 3-piece rims  |
|       | ● 23.5R25 tires on 3-piece rims  |
|       | ▲ ▲ 23.5R25 tires on 5-piece rims  |
| ▲ ▲ ▲ | Waste handler (Z-bar and High-Lift)  |
| ● ● ● | Level 1 sound package  |
| ▲ ▲ ▲ | Level 2 sound package  |
| ▲ ▲ ▲ | Transmission side-frame and bottom guards  |
|       | ▲ ▲ Fast-fuel system   |
| ● ●   | Fenders, front   |
| ▲ ▲ ● | Fenders, full-coverage, front  |
| ▲ ▲ ▲ | Fenders, full-coverage, front and rear   |
| ▲ ▲ ▲ | Less wheels and tires with axle stops  |
| ▲ ▲ ▲ | Rims less tires  |
| ▲ ▲ ▲ | Lift eyes  |
| ▲ ▲ ▲ | License-plate bracket and light  |
|       | ▲ Forestry-application package (Powerllec only)  |
| ▲ ▲ ▲ | Special guarding for waste and forestry applications   |

<sup>1</sup>Available only with EPA Final Tier 4 (FT4)/EU Stage IV engines.

<sup>§</sup>Available only on EPA Tier 3/EU Stage IIIA and EPA Tier 2/EU Stage II engines.

Net engine power is with standard equipment including air cleaner, exhaust system, alternator, and cooling fan at test conditions per ISO 9249. No derating is required up to 3050-m (10,000 ft.) altitude. Specifications and design subject to change without notice. Specifications with the exception of bucket capacity are in accordance with all applicable ISO standards. Except where otherwise noted, these specifications are based on units with applicable linkage and standard equipment, ROPS cab, rear cast bumper/counterweight, transmission side-frame guards, bottom guards, standard tires, full fuel tank, and 79-kg (175 lb.) operator.



**JOHN DEERE**

