



# HITACHI

## ZX50U-5N | ZX60USB-5N | ZAXIS-5 series

Reliable Solutions



ZX50U-5N

### SPEC SUMMARY

# ZAXIS 50 ZAXIS 60

Compact Excavators

	ZX50U-5N	ZX60USB-5N
Operating Weight	10,560 lb. (4,790 kg)	13,382 lb. (6,070 kg)
Net Power (ISO 9249)	36.8 hp (27.1 kW) @ 2,400 rpm	53.8 hp (39.6 kW) @ 2,000 rpm



# A PERFECT FIT: INTUITIVE COMPACT EXCAVATORS





**The ZAXIS-5N series of compact excavators puts you firmly in control, so you can feel confident in your machine's performance, and be supported by the technological expertise and services that Hitachi Construction Machinery Americas provides.**

# HIGH PERFORMANCE & QUALITY



## Versatility

- **Short tail swing** to work safely in narrow job sites. (ZX50U-5N)
- **1-way/2-way selector valve** for attachment mode (breaker and grapple).
- **Auxiliary hydraulic line diverter** to thumb or breaker and other attachment operation.
- **Wider working range** for small equipment.
- **Auxiliary function lever** for various attachments.

## Quality Details

- **Boom Cylinder Guard:** The boom cylinder is protected with a cylinder cover to increase durability.
- **Hose Protectors** protect hydraulic hoses on the boom arm.
- Standard **auxiliary hydraulic lines** are plumbed to the end of the boom to simplify attachment use.
- **Durable rubber tracks** minimize ground damage and allow machines to cross virtually any terrain, including paved surfaces.
- HN bushing applied on all front attachment joint parts for better greasing retention capacity.







ZX50U-5N



- **Standard backfill blade** adds versatility enabling these compact to grade and backfill as well as provide extra stability.

- **4 tie downs** on both left and right hand side of dozer blade and rear track for transportation.

### High-Performance

- **Full hydraulic pilot valve**
- **Higher productivity**
- **2 work modes** (Eco and Power) for desired productivity.
- **Eco friendly auto idling system** for lowering unnecessary fuel consumption and emission.
- **Hitachi High-Performance Hydraulic (HHH)** system makes optimum pump flow.



# EASY MAINTENANCE

**Easy, ground-level access** maintenance points for lubrication.

**Longer maintenance interval**

**Parallel-aligned cooling package** for easy cleanup.

**Larger engine cover and wider space** for maintenance.

**Easy** to clean radiators

**Wet-disc swing brake** provides long term maintenance-free performance.

**Hinged service door** provides wide-open access to the side-by-side oil cooler and radiator for easier core maintenance.

**Side-by-side cooling cores** resist debris buildup. Dedicated door provides easy access for cleaning.

**Spin-on filters** provide quick, easy access for filter maintenance.

**Ground level at-a-glance gauges** for ease of daily inspection and servicing.

**Tilting floor** for easy access maintenance.

**Vertical Sliding Engine Cover**

The upright engine cover, updated from the conventional model, slides vertically with less rear projection for ease of maintenance in confined spaces.

**Easy Access Fueling**

Large fueling port adapted from the larger excavator models allows for quick fueling.

**Easy Access Engine Compartment**

The operator seat tilts up to reveal the engine compartment for ease of maintenance.





ZX50U-5N

**Rugged Box-Section Blade**

The blade is box-section structure for higher ruggedness, and its stays have openings for easy flow-out of mud.



Box-section blade

**Sturdy Upperstructure**

The upperstructure frame is reinforced with job-proven D-section skirts whose height is increased for larger cross section to boost durability against obstacles.



D-section frame skirt



Parallel arrangement of radiator and oil cooler



Dust-proof indoor net



Split-type floor mat





- **Joystick controls** for effortless operation.
- **Ergonomic design** gives you convenient access to controls.
- **Multi-function LCD eco-display** makes operation easier.
- **Improved sound isolation** provides quiet environment for the operator (cab spec).
- **Optimal pedal layout** helps to reduce fatigue.
- **Hydraulic Pilot Control levers** provide smooth control of the front, blade, swing and travel. The levers are ergonomically arranged for easier access and to prevent fatigue.
- **Simple, easy to read LCD display** provides operational data at a glance.
- **Drink holder** is easy to reach from the operator station.



# CONTROL AND COMFORT ZONE

**Enhanced comfort and safety features are at your fingertips in the refined cab of ZAXIS-5N excavators, giving you the power to perform productively, with ease and reduced fatigue.**

**Spacious operator station**

Fitted with a wide and adjustable sliding suspension seat and adjustable arm rest, the ZX50U-5N and ZX60USB-5N provide a high level of comfort for operators.

**Easy operation**

Intuitive controls are in easy reach of the operator and the hydraulic pilot control levers ensure a smooth operation. Low noise levels allow operators to work more comfortably.

**Enhanced design**

The ZX50U-5N and ZX60USB-5N are equipped with lights on the cab and boom.

**Perfectly Positioned Pedals**

The swing boom and foldable travel pedals are positioned for easy operation, yet allow plenty of foot room.



ZX50U-5N

**Above: Joystick controls for effortless operation and multi-function LCD eco-display makes operation easier.**

**Left: Windshield tilt**



ZX50U-5N

**Comfort**

- Ergonomically designed operator station.
- Low noise level.
- Comfortable seat with suspension and slide features.
- Wider and spacious cabin with large door.
- 4 pillar open-canopy for safer and better visibility (ZX50U-5N)

**Easy Access**

Spacious operator stations have wide entryways, making entering and exiting the cab safe and easy.



# DURABILITY AND SAFETY



ZX50U-5N

## Durability and Safety

### HN Bushings

Grease impregnated HN bushings and pins provide long 500-hour lubricating intervals.

### Highly durable front attachment.

### Safety canopy to protect operator.

Boom hoses are positioned to protect from damages.

- The rugged Cab (ZX50U-5N and ZX60USB-5N) and 4-pillar canopy (ZX50U-5N) effectively protect the operator against tipping and falling objects. ROPS (Roll-Over Protective Structure).

### Neutral Engine Start System

The engine cannot start unless the shut-off lever is in the locked position, providing safe operation.



# SERVICE AND SUPPORT



ZX50U-5N

## Reducing the Total Cost of Ownership

Through our long-term commitment to maintaining a leadership position in technology and service, Hitachi Construction Machinery Americas supports an extensive network of independent, authorized local dealers focused on providing you with knowledgeable and experienced sales, service and parts personnel.

Your Hitachi Construction Machinery Americas authorized local dealer has the resources, knowledge and personnel to work with you to ensure that you receive the most benefit from your construction equipment investment utilizing carefully designed programs and services in conjunction with extensive hands' on training and digital resources.

Hitachi Construction Machinery Americas provides a totally focused approach to supporting you, your business, and your machines.

- Full manufacturer's warranty
- HELP, Hitachi Extended Life Program
- Local parts depot backed by the Hitachi Global Parts Network
- Hitachi Genuine parts



# ZX50U-5N SPECIFICATIONS

ENGINE	
Model	Yanmar 4TNV88C
Type	4-cycle water-cooled, common rail direct injection
Aspiration	Natural
Aftertreatment	DPF
No. of cylinders	4
Rated power	
ISO 14396: Gross	39.6 hp (29.1 kW) at 2,400 rpm
ISO 9249: Net	36.8 hp (27.1 kW) at 2,400 rpm
Maximum torque	100.2 lbf-ft (135.8 Nm) at 1,560 min-1
Piston displacement	134 cu. in. (2.189 L)
Bore and stroke	3.5" x 3.5" (88 mm x 90 mm)
Batteries	1 x 12 V/72 Ah

HYDRAULIC SYSTEM			
<b>Hydraulic Pumps</b>			
Main pumps	Closed center load sensing with variable-displacement pump		
Maximum oil flow	31.7 gpm (120 L/m)		
Auxiliary flow	23.1 gpm (87.5 L/min)		
Auxiliary Pressure	2,495 psi (17.2 MPa)		
<b>Hydraulic Motors</b>			
Travel	2 variable displacement axial piston motors		
Swing	1 axial piston motor		
<b>Relief Valve Settings</b>			
Implement circuit	3,553.4 psi (24.5 MPa)		
Swing circuit	2,654.2 psi (18.3 MPa)		
Travel circuit	3,553.4 psi (24.5 MPa)		
Pilot circuit	594.7 psi (4.1 MPa)		
<b>Hydraulic Cylinders</b> <span style="float: right;">Unit: in (mm)</span>			
	Quantity	Bore	Rod diameter
Boom (Canopy)	1	3.7" (95)	2.2" (55)
Boom (Cab)	1	3.7" (95)	2.2" (55)
Arm	1	3.1" (80)	2.0" (50)
Bucket	1	3.0" (75)	1.8" (45)
Blade	1	4.1" (105)	2.0" (50)
Angle blade	1	2.6" (65)	1.6" (40)
Boom swing	1	3.5" (90)	2.0" (50)

UPPERSTRUCTURE	
<b>Revolving Frame</b>	
D-section frame for resistance to deformation	
<b>Swing Device</b>	
Axial piston motor with planetary reduction gear is bathed in oil. Swing circle is single row. Swing parking brake is spring-set/hydraulic released disc type	
Swing speed	9.0 rpm
Swing torque	6,343.0 lbf-ft (8.6 kNm)
Max boom swing angle, left/right	80 degrees/60 degrees

UNDERCARRIAGE	
<b>Tracks</b>	
Tractor-type undercarriage. Welded track frame using selected materials. Side frame welded to track frame	
<b>Numbers of Rollers on Each Side</b>	
Upper rollers	1
Lower rollers	4
Steel track (optional)	39
<b>Travel Device</b>	
Each track driven by 2-speed axial piston motor. Parking brake is spring-set/hydraulic-released disc type. Automatic transmission system: High-Low	
Travel speeds	High: 0 to 2.6 mph (0 to 4.2 km/h)
	Low: 0 to 1.6 mph (0 to 2.5 km/h)
Maximum traction force	8,610.2 lbf (38.3 kN)
Gradeability	58% (30 degree) continuous

ENVIRONMENT	
<b>Engine Emissions</b>	EPA Final Tier 4
<b>Sound Level*</b>	
Sound level in canopy according to ISO 6396: 2008	*LpA 77.4 (right) / 77.2 (left) dB(A)
Sound level in cab according to ISO 6396: 2008	*LpA 76.8 (right) / 70.8 (left) dB(A)
External sound level according to ISO 6395: 2008	*LwA 97.0 (canopy) dB(A)

SERVICE REFILL CAPACITIES	
	Unit: gal (L)
Fuel tank	18.5 (70.0)
Engine coolant	1.3 (5.0)
Engine oil	2.2 (8.6)
Travel device (each side)	0.2 (0.9)
Hydraulic system	17.4 (66.0)
Hydraulic oil tank	14.8 (56.0)



## WEIGHTS AND GROUND PRESSURE

### Operating Weight and Ground Pressure

	Shoe width, in (mm)	Operating Weight lb (kg)	Ground Pressure psi (kPa)
*Rubber track, Canopy 4' 6" (1,380 mm) arm	16" (400 mm)	10,560 lb (4,790 kg)	4.0 psi (27.4 kPa)
*Rubber track, Cab 4' 6" (1,380 mm) arm	16" (400 mm)	10,847 lb (4,920 kg)	4.1 psi (28.1 kPa)
**Rubber track, Canopy 5' 7" (1,690 mm) arm	16" (400 mm)	11,054 lb (5,014 kg)	4.2 psi (28.8 kPa)
**Rubber track, Cab 5' 7" (1,690 mm) arm	16" (400 mm)	11,341 lb (5,144 kg)	4.3 psi (29.5 kPa)
*Steel track, Canopy 4' 6" (1,380 mm) arm	16" (400 mm)	10,957 lb (4,970 kg)	4.1 psi (28.0 kPa)
*Steel track, Cab, 4' 6" (1,380 mm) arm	16" (400 mm)	11,244 lb (5,100 kg)	4.2 psi (29.0 kPa)
**Steel track, Canopy 5' 7" (1,690 mm) arm	16" (400 mm)	11,442 lb (5,190 kg)	4.2 psi (29.0 kPa)
**Steel track, Cab 5' 7" (1,690 mm) arm	16" (400 mm)	11,729 lb (5,320 kg)	4.4 psi (30.0 kPa)

\*With full fuel tank, 16" (400 mm) rubber track, straight blade, 175 lb (79 kg) operator

\*\*With full fuel tank, 16" (400 mm) steel track, extra counterweight, straight blade, 175 lb (79 kg) operator

### Components Weight

Unit: lb (kg)

Counterweight	
Standard	1,543 (700)
Additional	441 (200)
Optional Angle Blade	902 (409)
Optional Angle Blade weight increase	485 (220)

## BUCKET AND ARM DIGGING FORCE

Unit: lbf (kN)

	4' 6" (1.380 m)	5' 7" (1.690 m)
Arm length		
Arm crowd force* ISO 6015: 2006	5,401 (24.0)	4,718 (21.0)
Bucket digging force* ISO 6015: 2006	8,267 (36.8)	8,267 (36.8)



# ZX50U-5N SPECIFICATIONS

## DIMENSIONS

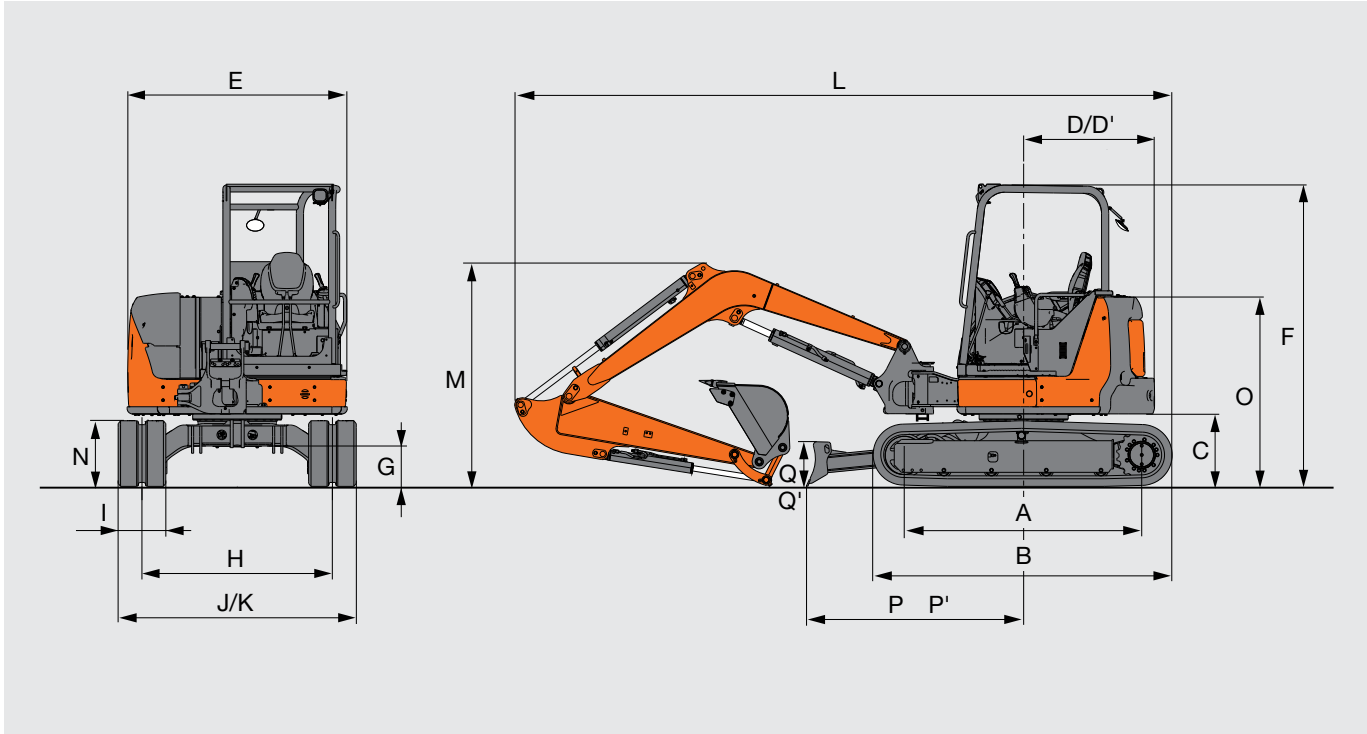

Unit: ft-in (mm)

		ZX50U-5N (Canopy)	ZX50U-5N (Canopy)	ZX50U-5N (Cab)	ZX50U-5N (Cab)
	Arm length	4' 6" (1,380)	5' 7" (1,690)	4' 6" (1,380)	5' 7" (1,690)
A	Distance between tumblers	6' 7" (2,000)	6' 7" (2,000)	6' 7" (2,000)	6' 7" (2,000)
B	Undercarriage length	8' 2" (2,500)	8' 2" (2,500)	8' 2" (2,500)	8' 2" (2,500)
C	Counterweight clearance	2' 1" (640)	2' 1" (640)	2' 1" (640)	2' 1" (640)
D	Rear-end swing radius	3' 3" (1,000)	3' 7" (1,100)	3' 3" (1,000)	3' 7" (1,100)
D'	Rear-end length	3' 3" (1,000)	3' 7" (1,100)	3' 3" (1,000)	3' 7" (1,100)
E	Overall width of upperstructure	6' 1" (1,850)	6' 1" (1,850)	6' 1" (1,850)	6' 1" (1,850)
F	Overall height of canopy/cab	8' 4" (2,530)	8' 4" (2,530)	8' 4" (2,530)	8' 4" (2,530)
G	Min. ground clearance	1' 1" (340)	1' 1" (340)	1' 1" (340)	1' 1" (340)
H	Track gauge	5' 3" (1,600)	5' 3" (1,600)	5' 3" (1,600)	5' 3" (1,600)
I	Track shoe width	16" (400)	16" (400)	16" (400)	16" (400)
J	Undercarriage width	6' 7" (2,000)	6' 7" (2,000)	6' 7" (2,000)	6' 7" (2,000)
K	Overall width	6' 7" (2,000)	6' 7" (2,000)	6' 7" (2,000)	6' 7" (2,000)
L	Overall length blade in front	17' 11" (5,470)	18' 1" (5,520)	17' 11" (5,470)	18' 1" (5,520)
M	Overall height of boom	5' 7" (1,710)	6' 2" (1,880)	5' 7" (1,710)	6' 2" (1,880)
N	Track height	1' 10" (550)	1' 10" (550)	1' 10" (550)	1' 10" (550)
O	Engine cover height	5' 3" (1,590)	5' 3" (1,590)	5' 3" (1,590)	5' 3" (1,590)
P	Horizontal distance to blade	6' 0" (1,820)	6' 0" (1,820)	6' 0" (1,820)	6' 0" (1,820)
P'	Horizontal distance to angle blade	6' 7" (2,015)	6' 7" (2,015)	6' 7" (2,015)	6' 7" (2,015)
Q	Blade height	1' 3" (375)	1' 3" (375)	1' 3" (375)	1' 3" (375)
Q'	Angle blade height	1' 3" (374)	1' 3" (374)	1' 3" (374)	1' 3" (374)



WORKING RANGES

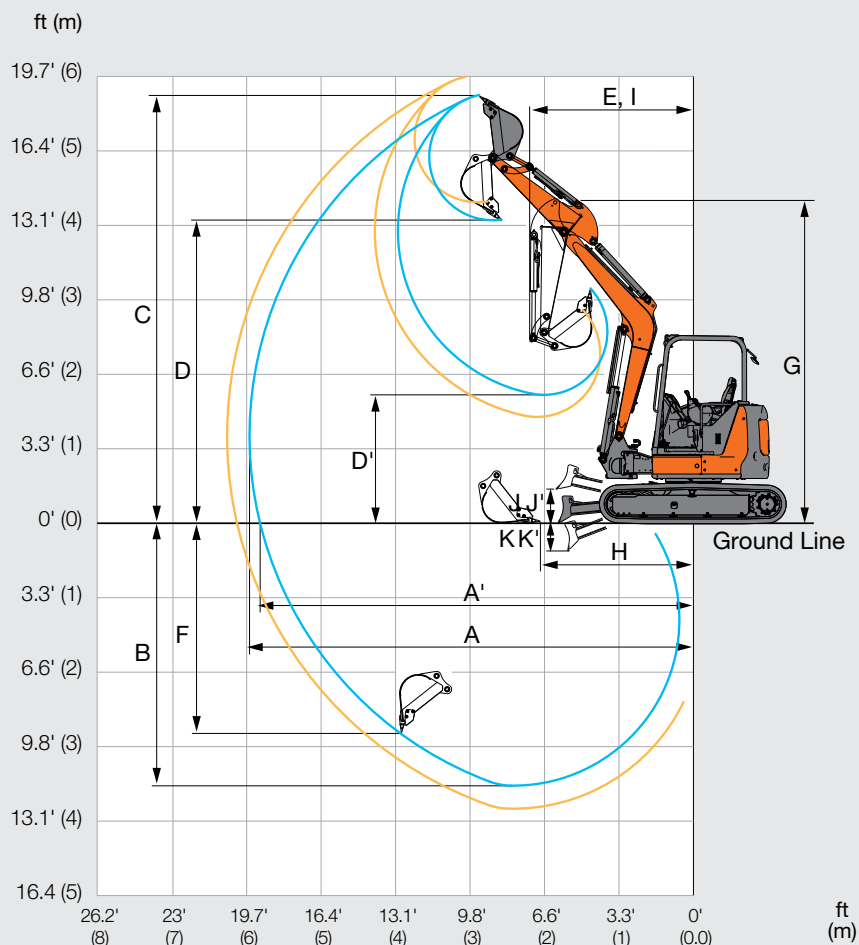

Unit: ft-in (mm)

		ZX50U-5N (Canopy)	ZX50U-5N (Canopy)	ZX50U-5N (Cab)	ZX50U-5N (Cab)
Arm length		4' 6" (1,380)	5' 7" (1,690)	4' 6" (1,380)	5' 7" (1,690)
A	Max. digging reach	19' 7" (5,960)	20' 6" (6,260)	19' 7" (5,960)	20' 6" (6,260)
A'	Max. digging reach (on ground)	19' 1" (5,820)	20' 1" (6,130)	19' 1" (5,820)	20' 1" (6,130)
B	Max. digging depth	11' 7" (3,530)	12' 7" (3,830)	11' 7" (3,530)	12' 7" (3,830)
C	Max. cutting height	18' 10" (5,750)	19' 8" (6,000)	18' 10" (5,750)	19' 8" (6,000)
D	Max. dumping height	13' 4" (4,070)	14' 2" (4,310)	13' 4" (4,070)	14' 2" (4,310)
D'	Min. dumping height	5' 8" (1,720)	4' 8" (1,430)	5' 8" (1,720)	4' 8" (1,430)
E	Min. swing radius	7' 3" (2,210)	7' 7" (2,300)	7' 3" (2,210)	7' 7" (2,300)
F	Max. vertical wall digging depth	9' 3" (2,810)	10' 4" (3,140)	9' 3" (2,810)	10' 4" (3,140)
G	Front height at Min. swing radius	14' 4" (4,380)	14' 4" (4,380)	14' 4" (4,380)	14' 4" (4,380)
H	Min. level crowding distance	6' 9" (2,050)	6' 2" (1,880)	6' 9" (2,050)	6' 2" (1,880)
I	Working radius at Min. swing radius (Max. boom-swing angle)	5' 8" (1,730)	5' 11" (1,810)	5' 8" (1,730)	5' 11" (1,810)
J	Blade bottom highest position	1' 6" (460)	1' 6" (460)	1' 6" (460)	1' 6" (460)
K	Blade bottom lowest position	1' 2" (365)	1' 2" (365)	1' 2" (365)	1' 2" (365)
J'	Angle blade bottom highest position	1' 6" (450)	1' 6" (450)	1' 6" (450)	1' 6" (450)
K'	Angle blade bottom lowest position	1' 7" (477)	1' 7" (477)	1' 7" (477)	1' 7" (477)
L/L'	Offset distance, left / right	2' 3" (690)/2' 9" (850)	2' 3" (690)/2' 9" (850)	2' 3" (690)/2' 9" (850)	2' 3" (690)/2' 9" (850)



# ZX50U-5N LIFTING CAPACITIES



A: Load radius  
 B: Load point height  
 C: Machine capacity

**Boldface type** indicates hydraulically limited capacity; lightface type indicates stability-limited capacities, in kg (lb.). Machine equipped with 6' 7" (2,000 mm) blade and 16" (400 mm) track; lifting measurement from center of arm to bucket pin; situated on firm, level, uniform supporting surface. Total load includes weight of cables, hook, etc. Figures do not exceed 87 percent of hydraulic capacities or 75 percent of weight needed to tip machine. All lift capacities are based on ISO 10567 (with power boost).

Rating over-front, Rating over-side or 360 degrees Unit: lb (kg)

ZX50U-5N								
	Rubber Track and Standard Counterweight		Steel Track and Standard Counterweight		Rubber Track and Extra Counterweight		Steel Track and Extra Counterweight	
Ground level at 10' (3.05 m) radius	Over Front	Over Side	Over Front	Over Side	Over Front	Over Side	Over Front	Over Side
4' 6" (1,380 mm) Standard Arm and Cab	<b>5,531</b> <b>(2,509)</b>	2,534 (1,149)	<b>5,531</b> <b>(2,509)</b>	2,618 (1,188)	<b>5,531</b> <b>(2,509)</b>	2,803 (1,271)	<b>5,531</b> <b>(2,509)</b>	2,888 (1,310)
5' 7" (1,690 mm) Long Arm and Cab	<b>5,456</b> <b>(2,475)</b>	2,486 (1,060)	<b>5,456</b> <b>(2,475)</b>	2,570 (1,166)	<b>5,456</b> <b>(2,475)</b>	2,755 (1,250)	<b>5,456</b> <b>(2,475)</b>	2,840 (1,288)
4' 6" (1,380 mm) Standard Arm and Canopy	<b>5,531</b> <b>(2,509)</b>	2,444 (1,109)	<b>5,531</b> <b>(2,509)</b>	1,125 (1,147)	<b>5,531</b> <b>(2,509)</b>	2,714 (1,231)	<b>5,531</b> <b>(2,509)</b>	2,798 (1,269)
5' 7" (1,690 mm) Long Arm and Canopy	<b>5,456</b> <b>(2,475)</b>	2,396 (1,087)	<b>5,456</b> <b>(2,475)</b>	2,480 (1,125)	<b>5,456</b> <b>(2,475)</b>	2,666 (1,209)	<b>5,456</b> <b>(2,475)</b>	2,750 (1,247)
Ground level at 15' (4.57) radius	Over Front	Over Side	Over Front	Over Side	Over Front	Over Side	Over Front	Over Side
4' 6" (1,380 mm) Standard Arm and Cab	<b>3,120</b> <b>(1,415)</b>	1,454 (660)	<b>3,120</b> <b>(1,415)</b>	1,504 (682)	<b>3,120</b> <b>(1,415)</b>	1,613 (665)	<b>3,120</b> <b>(1,415)</b>	1,644 (755)
5' 7" (1,690 mm) Long Arm and Cab	<b>3,060</b> <b>(1,388)</b>	1,416 (572)	<b>3,060</b> <b>(1,388)</b>	1,466 (665)	<b>3,060</b> <b>(1,388)</b>	1,575 (714)	<b>3,060</b> <b>(1,388)</b>	1,625 (737)
4' 6" (1,380 mm) Standard Arm and Canopy	<b>3,120</b> <b>(1,415)</b>	1,401 (635)	<b>3,120</b> <b>(1,415)</b>	1,451 (658)	<b>3,120</b> <b>(1,415)</b>	1,560 (708)	<b>3,120</b> <b>(1,415)</b>	1,611 (731)
5' 7" (1,690 mm) Long Arm and Canopy	<b>3,060</b> <b>(1,388)</b>	1,363 (618)	<b>3,060</b> <b>(1,388)</b>	1,413 (641)	<b>3,060</b> <b>(1,388)</b>	1,522 (690)	<b>3,060</b> <b>(1,388)</b>	1,572 (713)

# ZX50U-5N EQUIPMENT

●: Standard equipment ○: Optional equipment

ENGINE	ZX50U-5N
Yanmar 4TNV88C 134 cu. in. (2.189 L)	●
ISO 9249: 36.8 hp (27.1 kW) at 2,400 rpm	●
ISO 14396: 39.6 hp (29.1 kW) at 2,400 rpm	●
55 amp alternator, 12 volt	●
Antifreeze	●
Certified to EPA Tier 4 Final	●
Direct injection	●
Electric fuel shutoff	●
Fan guard	●
Fuel filter & water separator	●
Full flow oil filter	●
Isolation mounted	●
Low maintenance battery	●
Single dry-type air filter	●
Under hood muffler	●
DPF	●

HYDRAULIC SYSTEM	ZX50U-5N
<b>NEW</b> 2nd auxiliary hydraulic coupler piping	○
<b>NEW</b> Auxiliary flow rate changer (5-stage)	●
<b>NEW</b> Auxiliary function control and right hand pilot lever	●
Auxiliary hydraulic diverter for breaker or thumb on arm to arm	●
Auxiliary valve section	●
Axial plunger swing motor	●
Boom swing foot control	●
Closed-center, load sensing with one variable displacement pump	●
Excavator to backhoe control pattern change	●
Full flow oil filter	●
Hydraulic pilot controls for boom, arm, bucket, swing, blade and propel	●
<b>NEW</b> Pilot accumulator	○
<b>NEW</b> Quick coupler piping	○
Wet disk swing brake	●

UNDERCARRIAGE	ZX50U-5N
16" (400 mm) rubber track	●
16" (400 mm) steel track	○
16" (400 mm) rubber pad track	○
Angle blade	○
Axial plunger propel motor	●
Backfill blade 6' 7" (2.0 m)	●
<b>NEW</b> Blade float (not available for Angle blade)	○
Planetary final drive	●
Propel motor shield	●
Two speed travel with automatic shifting	●

UPPER STRUCTURE	ZX50U-5N
360 degree upper structure rotation	●
<b>NEW</b> Battery disconnect switch	●
Counterweight; 1,190 lb (540 kg)	●
Additional Counterweight; 441 lb (200 kg)	○
Independent boom swing (80 degree left and 60 degree right rotation)	●
ROPS/OPG/FOPS canopy	●
ROPS/OPG/FOPS cab with air conditioning and heater	○
Vandal locks for service doors	●
<b>NEW</b> LED work light	
One mounted on boom	●
One mounted on canopy (cab)	●
Zero swing configuration	●

FRONT ATTACHMENTS	ZX50U-5N
Boom 9' 4" (2.85 m)	●
Arm 4' 6" (1.38 m)	●
Arm 5' 7" (1.69 m)	○
Mechanical quick coupler	●
<b>NEW</b> Seatscrew for quick coupler piping	●

OPERATOR'S STATION	ZX50U-5N
12 Volt outlet	●
<b>NEW</b> 3 in. retractable seat belt	●
Air conditioner for cab	○
<b>NEW</b> Blade lever with High & Low travel switch	●
<b>NEW</b> CAB front window power assist dampener (CAB only)	○
Cupholder	●
Electronic throttle control with auto idle and auto shut-down	●
Foldable propel pedals and levers	●
Horn	●
Instrumentation lights	●
Monitor system with:	
Alternator voltage warning indicator"	●
Auto idle indicator	●
Auto shut-down indicator	●
Clock	●
Diagnostic capability	●
Engine coolant temperature gauge and indicator	●
Engine oil pressure indicator	●
Engine coolant temperature gauge, overheat indicator and alarm	●
Engine oil pressure indicator	●
Engine preheat indicator	●
Fuel gauge with low fuel indicator	●
Hour meter	●
Muffler filter indicator	●
Power/Economy mode	●
System monitoring capability	●
Travel mode indicator	●
Work lights indicator	●
Motion alarm with cancel switch	●
Operator manual storage in back of seat	●
Seat with fore/aft adjustment	●
<b>NEW</b> Telematics	●
Two travel modes with automatic shifting and speed selection switch	●
<b>NEW</b> USB power outlet (CAB only)	○
Work lights switch	●



# ZX60USB-5N SPECIFICATIONS

ENGINE	
Model	Yanmar 4TNV98C
Type	4-cycle water-cooled, common rail direct injection
Aspiration	Natural
Aftertreatment	DPF
No. of cylinders	4
Rated power	
ISO 14396: Gross	57.6 hp (42.4 kW) at 2,000 rpm
ISO 9249: Net	53.8 hp (39.6 kW) at 2,000 rpm
Maximum torque	166.7 lbf-ft (226.0 Nm) at 1,300 min-1
Piston displacement	202 cu. in. (3.318 L)
Bore and stroke	3.9" x 4.3" (98 mm x 110 mm)
Batteries	1 x 12 V/92 Ah

HYDRAULIC SYSTEM			
<b>Hydraulic Pumps</b>			
Main pumps	Closed center load sensing with variable-displacement pump		
Maximum oil flow	38.0 gpm (144 L/m)		
Auxiliary flow	24.2gpm (90 L/min)		
Auxiliary Pressure	2,495 psi (17.2 MPa)		
<b>Hydraulic Motors</b>			
Travel	2 variable displacement axial piston motors		
Swing	1 axial piston motor		
<b>Relief Valve Settings</b>			
Implement circuit	3,553.4 psi (24.5 MPa)		
Swing circuit	2,842.7 psi (19.6 MPa)		
Travel circuit	3,727.5 psi (25.7 MPa)		
Pilot circuit	594.7 psi (4.1 MPa)		
<b>Hydraulic Cylinders</b> <span style="float: right;">Unit: in (mm)</span>			
	Quantity	Bore	Rod diameter
Boom (Cab)	1	4.3" (110)	2.4" (60)
Arm	1	3.5" (90)	2.2" (55)
Bucket	1	3.1" (80)	2.0" (50)
Blade	1	4.7" (120)	2.8" (70)
Angle blade	1	2.8" (70)	1.6" (40)
Boom swing	1	3.7" (95)	2.2" (55)

UPPERSTRUCTURE	
<b>Revolving Frame</b>	
D-section frame for resistance to deformation	
<b>Swing Device</b>	
Axial piston motor with planetary reduction gear is bathed in oil. Swing circle is single row. Swing parking brake is spring-set/hydraulic released disc type	
Swing speed	9.5 rpm
Swing torque	8,113.2 lbf-ft (11 kNm)
Max boom swing angle, left/right	80 degrees/60 degrees

UNDERCARRIAGE	
<b>Tracks</b>	
Tractor-type undercarriage. Welded track frame using selected materials. Side frame welded to track frame	
<b>Numbers of Rollers on Each Side</b>	
Upper rollers	1
Lower rollers	4
Steel track (optional)	39
<b>Travel Device</b>	
Each track driven by 2-speed axial piston motor. Parking brake is spring-set/hydraulic-released disc type. Automatic transmission system: High-Low	
Travel speeds	High: 0 to 3.0 mph (0 to 4.8 km/h)
	Low: 0 to 1.8 mph (0 to 2.9 km/h)
Maximum traction force	8,947.4 lbf (39.8 kN)
Gradeability	46.6% (25 degree) continuous

ENVIRONMENT	
Engine Emissions	EPA Final Tier 4
<b>Sound Level*</b>	
Sound level in cab according to ISO 6396: 2008	*LpA 78.0 (right) / 78.5 (left) dB(A)
External sound level according to ISO 6395: 2008	*LwA 100.3 dB(A)

SERVICE REFILL CAPACITIES	
	Unit: gal (L)
Fuel tank	31.7 (120.0)
Engine coolant	2.0 (7.7)
Engine oil	2.9 (11.2)
Travel device (each side)	0.2 (0.9)
Hydraulic system	28.4 (107.5)
Hydraulic oil tank	21.1 (80.0)

## WEIGHTS AND GROUND PRESSURE

### Operating Weight and Ground Pressure

	Shoe width, in (mm)	Operating Weight lb (kg)	Ground Pressure psi (kPa)
*Rubber track, Cab 4' 11" (1,500 mm) arm	16" (400 mm)	13,382 lb (6,070 kg)	5.1 psi (35.0 kPa)
*Rubber track, Cab, 6' 1" (1,850 mm) arm	16" (400 mm)	13,426 lb (6,090 kg)	5.4 psi (37.0 kPa)
*Steel track, Cab 4' 11" (1,500 mm) arm	16" (400 mm)	13,779 lb (6,250 kg)	5.2 psi (36.0 kPa)
*Steel track, Cab 6' 1" (1,850 mm) arm	16" (400 mm)	14,418 lb (6,540 kg)	5.4 psi (37.0 kPa)

\*With 1,642lb (745kg) counterweight, full fuel tank, straight blade, 165 lb (79 kg) operator

### Components Weight

Unit: lb (kg)

Counterweight	
Standard	1,642 (745)
Additional	595 (270)
Optional Angle Blade	1,010 (458)
Optional Angle Blade weight increase	683 (310)

## BUCKET AND ARM DIGGING FORCE

Unit: lbf (kN)

Arm length	4' 11" (1.500 m)	6' 1" (1.850 m)
Arm crowd force* ISO 6015: 2006	6,989 (31.1)	6,063 (27.0)
Bucket digging force* ISO 6015: 2006	9,237 (41.1)	9,237 (41.1)



# ZX60USB-5N SPECIFICATIONS

## DIMENSIONS

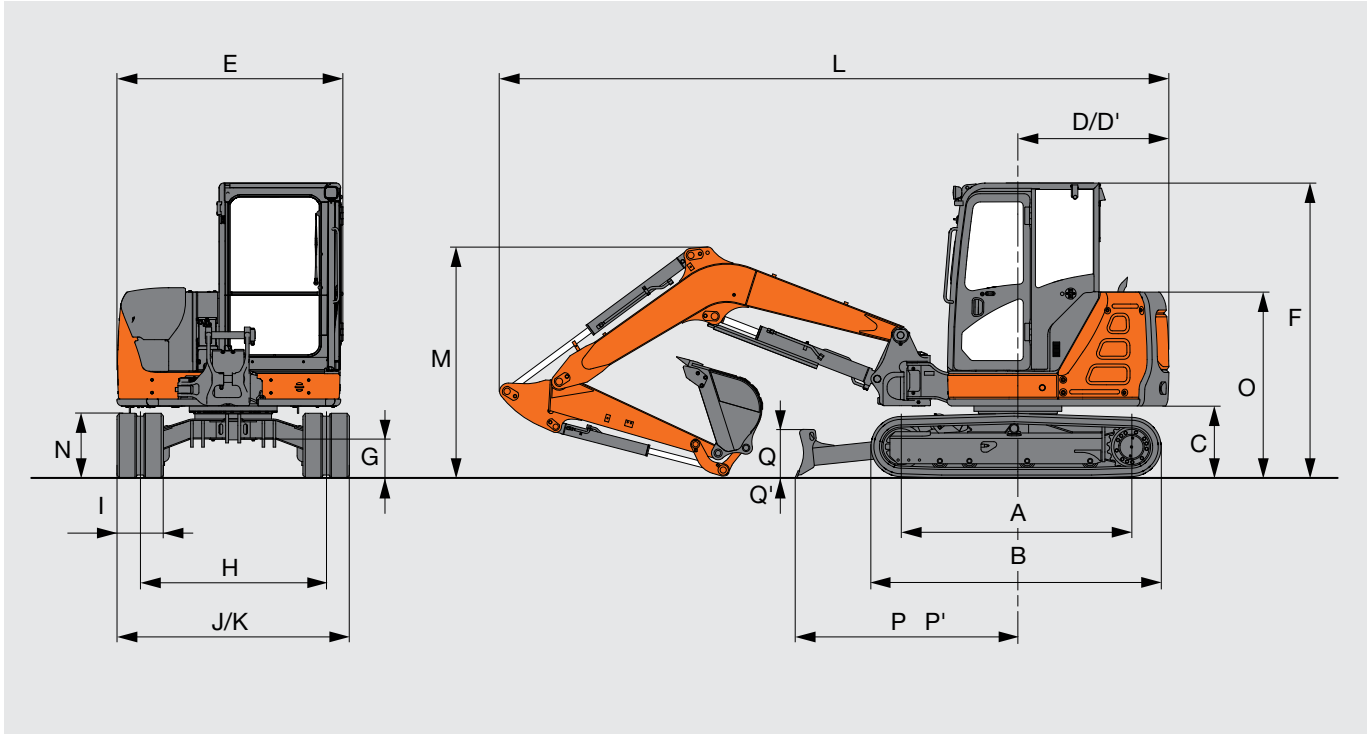

Unit: ft-in (mm)

		ZX60USB-5N (Cab)	ZX60USB-5N (Cab)
	Arm length	4' 11" (1,500)	6' 1" (1,850)
A	Distance between tumblers	6' 6" (1,990)	6' 6" (1,990)
B	Undercarriage length	8' 2" (2,500)	8' 2" (2,500)
C	Counterweight clearance	2' 0" (620)	2' 0" (620)
D	Rear-end swing radius	4' 3" (1,300)	4' 8" (1,410)
D'	Rear-end length	4' 3" (1,300)	4' 8" (1,410)
E	Overall width of upperstructure	6' 3" (1,930)	6' 3" (1,930)
F	Overall height of cab	8' 4" (2,540)	8' 4" (2,540)
G	Min. ground clearance	1' 1" (340)	1' 1" (340)
H	Track gauge	5' 3" (1,600)	5' 3" (1,600)
I	Track shoe width	16" (400)	16" (400)
J	Undercarriage width	6' 7" (2,000)	6' 7" (2,000)
K	Overall width	6' 7" (2,000)	6' 7" (2,000)
L	Overall length blade in front	18' 11" (5,760)	19' 0" (5,790)
M	Overall height of boom	6' 6" (1,980)	7' 1" (2,170)
N	Track height	1' 10" (560)	1' 10" (560)
O	Engine cover height	5' 3" (1,600)	5' 3" (1,600)
P	Horizontal distance to blade	6' 4" (1,920)	6' 4" (1,920)
P'	Horizontal distance to angle blade	6' 7" (2,019)	6' 7" (2,019)
Q	Blade height	1' 5" (420)	1' 5" (420)
Q'	Angle blade height	1' 4" (408)	1' 4" (408)

WORKING RANGES

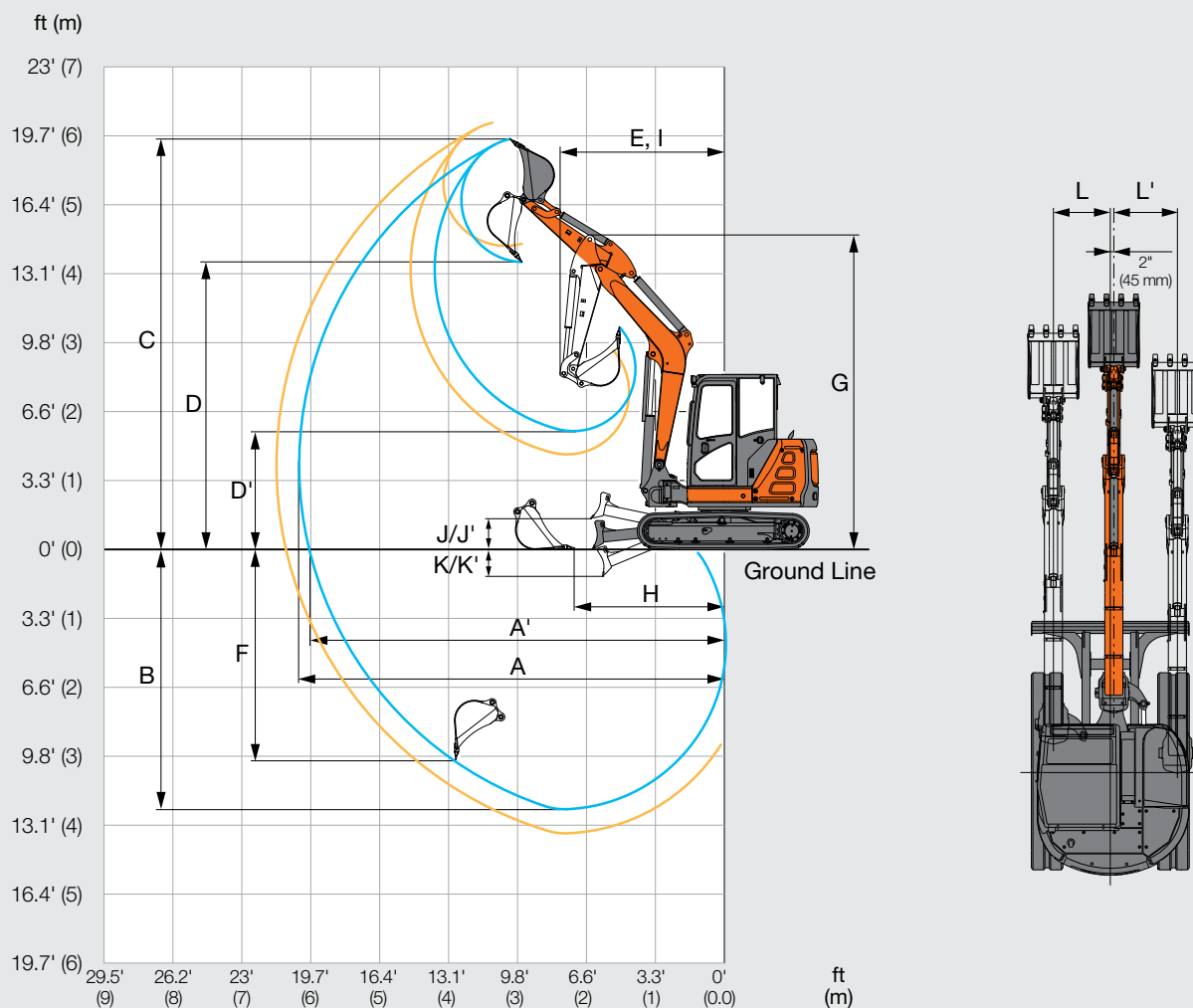

Unit: ft-in (mm)

	ZX60USB-5N (Cab)	ZX60USB-5N (Cab)
Arm length	4' 11" (1,500)	6' 1" (1,850)
A Max. digging reach	20' 5" (6,230)	21' 6" (6,560)
A' Max. digging reach (on ground)	19' 11" (6,080)	21' 1" (6,420)
B Max. digging depth	12' 4" (3,770)	13' 6" (4,120)
C Max. cutting height	19' 7" (5,960)	20' 4" (6,190)
D Max. dumping height	13' 8" (4,170)	14' 6" (4,410)
D' Min. dumping height	5' 8" (1,720)	4' 6" (1,380)
E Min. swing radius	8' 0" (2,450)	8' 4" (2,540)
F Max. vertical wall digging depth	10' 0" (3,050)	11' 1" (3,390)
G Front height at Min. swing radius	15' (4,560)	15' (4,560)
H Min. level crowding distance	7' 1" (2,170)	6' 7" (2,000)
I Working radius at Min. swing radius (Max. boom-swing angle)	6' 6" (1,980)	6' 9" (2,060)
J Blade bottom highest position	1' 6" (450)	1' 6" (450)
K Blade bottom lowest position	1' 3" (390)	1' 3" (390)
J' Angle blade bottom highest position	1' 5" (424)	1' 5" (424)
K' Angle blade bottom lowest position	1' 6" (450)	1' 6" (450)
L/L' Offset distance, left/right	2'4" (720)/2'9" (850)	2'4" (720)/2'9" (850)



# ZX60USB-5N LIFTING CAPACITIES



A: Load radius  
 B: Load point height  
 C: Machine capacity

**Boldface type** indicates hydraulically limited capacity; lightface type indicates stability-limited capacities, in kg (lb.). Machine equipped with 6' 7" (2000 mm) blade and 16" (400 mm) track; lifting measurement from center of arm to bucket pin; situated on firm, level, uniform supporting surface. Total load includes weight of cables, hook, etc. Figures do not exceed 87 percent of hydraulic capacities or 75 percent of weight needed to tip machine. All lift capacities are based on ISO 10567 (with power boost).

Rating over-front, Rating over-side or 360 degrees Unit: lb (kg)

ZX60USB-5N								
	Rubber Track and Standard Counterweight		Steel Track and Standard Counterweight		Rubber Track and Extra Counterweight		Steel Track and Extra Counterweight	
<b>Ground level at 9' 10" (3 m) radius</b>	<b>Over Front</b>	<b>Over Side</b>	<b>Over Front</b>	<b>Over Side</b>	<b>Over Front</b>	<b>Over Side</b>	<b>Over Front</b>	<b>Over Side</b>
4' 11" (1,500 mm) Standard Arm and Cab	<b>8,550</b> <b>(3,880)</b>	3,310 (1,500)	<b>8,550</b> <b>(3,880)</b>	3,350 (1,520)	<b>8,550</b> <b>(3,880)</b>	3,730 (1,690)	<b>8,550</b> <b>(3,880)</b>	3,790 (1,720)
6' 1" (1,850 mm) Long Arm and Cab	<b>8,400</b> <b>(3,810)</b>	3,260 (1,480)	<b>8,400</b> <b>(3,810)</b>	3,310 (1,500)	<b>8,400</b> <b>(3,810)</b>	3,700 (1,680)	<b>8,400</b> <b>(3,810)</b>	3,750 (1,700)
<b>Ground level at 13' 2" (4 m) radius</b>	<b>Over Front</b>	<b>Over Side</b>	<b>Over Front</b>	<b>Over Side</b>	<b>Over Front</b>	<b>Over Side</b>	<b>Over Front</b>	<b>Over Side</b>
4' 11" (1,500 mm) Standard Arm and Cab	<b>5,620</b> <b>(2,550)</b>	2,230 (1,010)	<b>5,620</b> <b>(2,550)</b>	2,270 (1,030)	<b>5,620</b> <b>(2,550)</b>	2,510 (1,140)	<b>5,620</b> <b>(2,550)</b>	2,560 (1,160)
6' 1" (1,850 mm) Long Arm and Cab	<b>5,470</b> <b>(2,480)</b>	2,180 (990)	<b>5,470</b> <b>(2,480)</b>	2,230 (1,010)	<b>5,470</b> <b>(2,480)</b>	2,490 (1,130)	<b>5,470</b> <b>(2,480)</b>	2,540 (1,150)
<b>Ground level at 16' 5" (5 m) radius</b>	<b>Over Front</b>	<b>Over Side</b>	<b>Over Front</b>	<b>Over Side</b>	<b>Over Front</b>	<b>Over Side</b>	<b>Over Front</b>	<b>Over Side</b>
4' 11" (1,500 mm) Standard Arm and Cab	<b>4,190</b> <b>(1,900)</b>	1,650 (750)	<b>4,190</b> <b>(1,900)</b>	1,670 (760)	<b>4,190</b> <b>(1,900)</b>	1,870 (850)	<b>4,190</b> <b>(1,900)</b>	1,900 (860)
6' 1" (1,850 mm) Long Arm and Cab	<b>4,120</b> <b>(1,870)</b>	1,610 (730)	<b>4,120</b> <b>(1,870)</b>	1,630 (740)	<b>4,120</b> <b>(1,870)</b>	1,830 (830)	<b>4,120</b> <b>(1,870)</b>	1,870 (850)

# ZX60USB-5N EQUIPMENT

●: Standard equipment ○: Optional equipment

ENGINE	ZX60USB-5N
Yanmar 4TNV98C 202 cu. in. (3.318 L)	●
ISO 9249: 53.8 hp (39.6 kW) at 2,000 rpm	●
ISO 14396: 57.6 hp (42.4 kW) at 2,000 rpm	●
55 amp alternator, 12 volt	●
Antifreeze	●
Certified to EPA Tier 4 Final	●
Electric fuel shutoff	●
Fan guard	●
Fuel filter & water separator	●
Full flow oil filter	●
Isolation mounted	●
Low maintenance battery	●
Single dry-type air filter	●
Under hood muffler	●
DPF	●

HYDRAULIC SYSTEM	ZX60USB-5N
<b>NEW</b> 2nd auxiliary hydraulic coupler piping	○
<b>NEW</b> Auxiliary flow rate changer (5-stage)	●
Auxiliary function control and right hand pilot lever	●
<b>NEW</b> Auxiliary hydraulic diverter for breaker or thumb on arm to arm	●
Auxiliary valve section	●
Axial plunger swing motor	●
Boom swing foot control	●
Closed-center, load sensing with one variable displacement pump	●
Excavator to backhoe control pattern change	●
Full flow oil filter	●
Hydraulic pilot controls for boom, arm, bucket, swing, blade and propel	●
<b>NEW</b> Pilot accumulator	○
<b>NEW</b> Quick coupler piping	○
Wet disk swing brake	●

UNDERCARRIAGE	ZX60USB-5N
16" (400 mm) rubber track	●
16" (400 mm) steel track	○
16" (400 mm) rubber pad track	○
Angle blade	○
Axial plunger propel motor	●
Backfill blade 6' 7" (2.0 m)	●
<b>NEW</b> Blade float (not available for Angle blade)	●
Planetary final drive	●
Propel motor shield	●
Two speed travel with automatic shifting	●

UPPER STRUCTURE	ZX60USB-5N
360 degree upper structure rotation	●
<b>NEW</b> Battery disconnect switch	●
Counterweight; 1,642 lb (745 kg)	●
Additional Counterweight; 595 lb (270 kg)	○
Independent boom swing (80 degree left and 60 degree right rotation)	●
ROPS/OPG/FOPS cab with air conditioning and heater	●
Tool box	●
Vandal locks for service doors	●
<b>NEW</b> LED work light	
One mounted on boom	●
One mounted on canopy (cab)	●

FRONT ATTACHMENTS	ZX60USB-5N
Boom 9' 9" (2.97 m)	●
Arm 4' 11" (1.55 m)	●
Arm 6' 1" (1.85 m)	○
Mechanical quick coupler	●
<b>NEW</b> Seatscrew for quick coupler piping	●

OPERATOR'S STATION	ZX60USB-5N
12 Volt outlet	●
<b>NEW</b> 3 in. retractable seat belt	●
Air Conditioning and heater	●
<b>NEW</b> Blade lever with High & Low travel switch	●
<b>NEW</b> CAB front window power assist dampener (CAB only)	○
Cupholder	●
Electronic throttle control with auto idle	●
Foldable propel pedals and levers	●
Horn	●
Instrumentation lights	●
Monitor system with:	
Alternator voltage indicator	●
Auto idle indicator	●
Auto shut-down indicator	●
Clock	●
Diagnostic capability	●
Engine coolant temperature gauge and indicator"	●
Engine oil pressure indicator	●
Engine preheat indicator	●
Fuel gauge and level indicator	●
Hour meter	●
Muffler filter indicator	●
Power/Economy mode	●
System monitoring capability	●
Travel mode indicator	●
Work lights indicator	●
Motion alarm with cancel switch	●
Operator manual storage in back of seat	●
Suspension seat	●
<b>NEW</b> Telematics	●
Two travel modes with automatic shifting and speed selection switch	●
<b>NEW</b> USB power outlet (CAB only)	○
Work lights switch	●





# HITACHI

## Reliable Solutions



REPUTATIONS ARE  
**BUILT ON IT.**

Hitachi Construction Machinery Americas Inc. is a leading provider of construction and mining machinery services and solutions in North and Latin America. Our manufacturing facilities are located in Banshu, Ryugasaki, Tierra, Hitachinaka, and Tsuchiura, Japan, while our U.S. corporate office is in Newnan, Georgia. Our experienced team of professionals is well-equipped to design, engineer, manufacture, and service your machinery.

Through our long-term commitment to maintaining a leadership position in technology, service, and support, we support an extensive network of independent, local dealers focused on providing you with knowledgeable and experienced sales, service, and parts personnel — all backed by our dedicated support teams.

Your Hitachi Construction Machinery Americas authorized local dealer has the resources, expertise, and personnel to work with you to ensure that you receive the most benefit from your investment. You can also utilize carefully designed programs and services in conjunction with extensive digital resources. Our focus is entirely on supporting you, your business, and your machinery.

If you are searching for a reliable partner for your construction machinery needs, we invite you to explore our offerings and experience the difference with Hitachi Construction Machinery Americas.

Machines representative of global product. Options may not be available in all markets. Prior to operating this machine, including satellite communication system, in a country other than a country of its intended use, it may be necessary to make modifications to it so that it complies with the local regulatory standards (including safety standards) and legal requirements of that particular country. Please do not export or operate this machine outside the country of its intended use until such compliance has been confirmed. Please contact your Hitachi Construction Machinery Americas authorized local dealer in case of questions about compliance. These specifications are subject to change without notice. Illustrations and photos show the standard models, and may or may not include optional equipment, accessories, and all standard equipment with some differences in color and features. Before use, read and understand the Operator's Manual for proper operation.