

SKID STEER MULCHER

GRIZZLY M450s



GRIZZLY M450s

The mulcher Grizzly M450s is designed for the compact loader segment or other hydraulic-driven carriers.

Developed for a range of carrier vehicles from 70–180 hp and with a volume flow between 22.5–66 gpm (85–250 l/min) the Grizzly M450s is a compact and powerful head for a diversity of mulching applications.

BENEFITS

- Perfect visibility
- Lightweight
- Optional protection flap
- Powerful

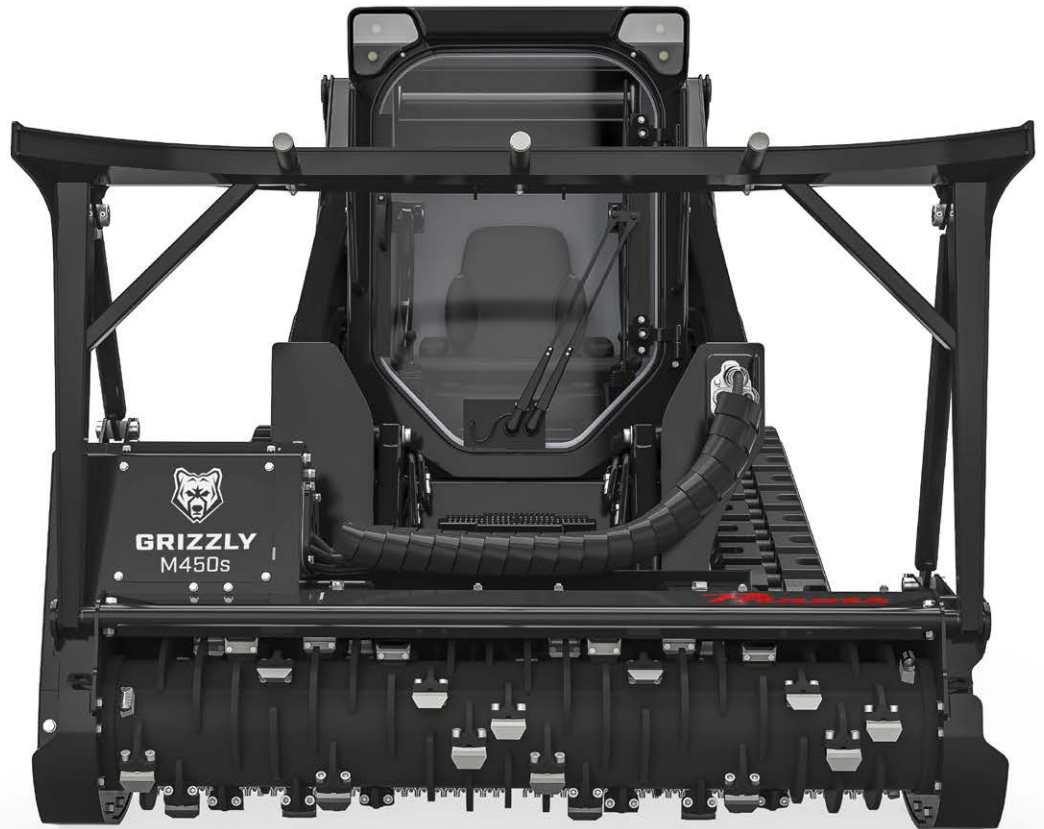

GRIZZLY M450s – HIGHLIGHTS



LIGHTWEIGHT

A lightweight mulching head provides more safety. The point of gravity is close to the carrier which means it provides easier handling and less tipping or roll over danger.



FAST ASSEMBLY

Hydraulic hoses with standard fittings are included in the package and already delivered from factory.

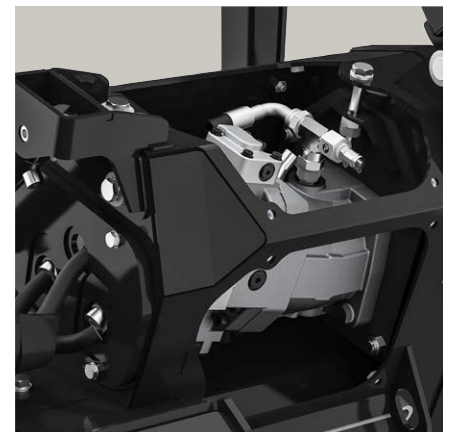

POWERFUL

The Grizzly M450s is equipped with a strong 107 cc Rexroth HD variable axial piston motor. The strong polybelt with 2.7 in (68 mm) transfers the power to the rotor. The low maintenance polybelt concept saves valuable time.

TECHNICAL DATA

	1600	1900	2200
Power range	70 – 150 hp	80 – 150 hp	100 – 180 hp
Volume flow	22.5 – 52.8 gpm (85 – 200 l/min)	24.6 – 52.8 gpm (100 – 200 l/min)	31.7 – 66 gpm (120 – 250 l/min)
Variable HD displacement	107 cc	107 cc	170 cc
piston motor			
Tools	32 x BCS / 40 x UPTs	40 x BCS / 48 x UPTs	48 x BCS
Working width	63 in (1,600 mm)	74.8 in (1,900 mm)	86.88 in (2,200 mm)
Total width	74.8 in (1,900 mm)	86.6 in (2,200 mm)	98.4 in (2,500 mm)
Weight*	2,513 lbs (1,140 kg)	2,668 lbs (1,210 kg)	3,042 lbs (1,380 kg)

*Weight depending on the configuration of the machine. Optional with or without a flap.

BCS ROTOR TOOLS



BCS02

Triple-carbide tool with main cutting tip in the center, side tips set diagonally to reduce power requirement, for wear-intensive and sandy applications.



BCS03

One-edged chipper blade with hardened surface for above-ground mulching, mounted on standard BCS holder.



BCS08

Wider tool with 4 thick carbide tips, particularly resistant to stony soils! Ideal for shredding in wear-intensive applications with heavy ground contact and rock content.

UPTs ROTOR TOOLS

GRIZZLY M450s



UPTs02

Finest and most consistent mulch results through double-tip knife geometry, recommended use for wood and limited rock.



UPTs04

Extremely aggressive tool with best penetration, very low power requirement, additional carbide plates for abrasive ground conditions, wide range of applications.



UPTs07

Extremely shock resistant in rocky ground, all-around reliability.



UPTs05 / 06

Side scraper to protect outer tool holders and clear remnants between rotor and housing. Unique carbide pattern at the outer edges, left or right version.



UPTs08 / BCS03

UPTs-holder for BCS03 tools, one-edged chipper blade with hardened surface for above-ground mulching.



BCS BITE-CONTROL-SYSTEM

BCS-Rotor with steel knives or carbide teeth. Best balanced rotor for less wear on bearings and high speed meaning high productivity and perfect finishing.

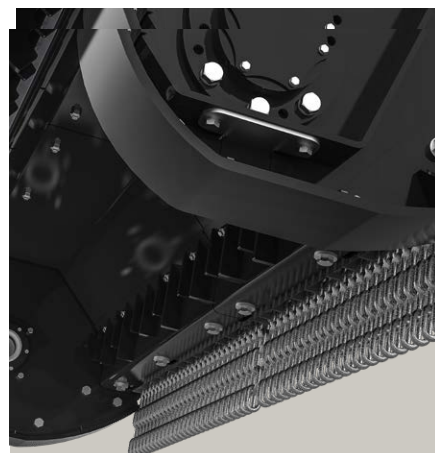

EXCHANGEABLE BOLTED COUNTER BLADES

The housing is equipped standard with bolted liners with counter blades. The liners are made out of highly wear-resistant steel and are easy exchangeable.

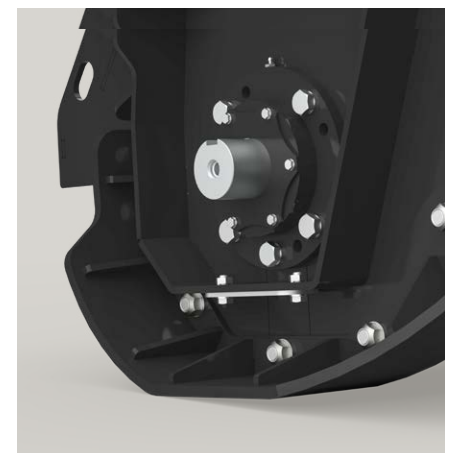

SKIDS

The skids are designed to allow a flexible working performance. Due to the shape, it is possible while tilting that the rotor has an improved contact to the ground material.

Prinoth GmbH

Im Branden 15
88634 Herdwangen
GERMANY
Phone +49 7557 92120
prinoth.germany@prinoth.com

Prinoth

1730 N Gault St
St Peter, MN 56082
USA
sales.vm.na@prinoth.com

Locate your nearest sales and service points at **prinoth.com**

© 2024. Technical specifications depend on equipment and may vary. Illustrations may contain optional features that do not come as standard. Prinoth reserves the right to make changes and updates at any time without prior notice. Version 07/2024