



ESSENTIAL IP65 TRI PROOF 36W LED BATTEN

Model No	21794/05
Wattage	36W

Before first using your new Brilliant LED Batten it is most important that you read and follow these instructions, even if you feel you are quite familiar with this type of product. Retain this document for future reference.

ALTHOUGH THIS FITTING IS ‘DIY - DO IT YOURSELF’, BRILLIANT LIGHTING RECOMMENDS THIS PRODUCT TO BE INSTALLED BY A LICENSED ELECTRICIAN.



Specifications:

- Fitting : IP65 Fixed LED luminaire with PC body and diffuser.
- Rated Supply Voltage: 220V-240V AC, 50Hz.
- Power: 36W
- Light Source: LED. 3600lm, 4000K (Cool White)
- Protection Class : Class 2.
- Ingress Protection: IP65 (Resistant to dust and water).
- Impact Rating: IK08
- Fixing: Surface mounted. Intended to be used while fastened to a support.
- Dimming: Non Dimmable.

Dimensions:

Model	Length (mm)	Width (mm)	Height (mm)
21794/05	1200	100	73

For Your Safety, please read this instruction manual carefully before installation:

- Installation in accordance with Australian Standards and local Building codes.
- Do not install in a position where the fixture can be easily accessed by children or infirm persons.
- Do not perform modification to the fixture.
- Do not touch the fixture when switched on.
- This fixture is not dimmable.
- This fixture has no serviceable parts – if faulty or damaged, dispose of thoughtfully in accordance with local government guidelines.
- Failure to follow these instructions will void the warranty.

Environmental Protection:

This electrical product should not be disposed as normal waste. Please always recycle! Check with your Local Council about your recycle options.





ESSENTIAL IP65 TRI PROOF 36W LED BATTEN

Model No	21794/05
Wattage	36W

ALTHOUGH THIS FITTING IS 'DIY - DO IT YOURSELF', BRILLIANT LIGHTING RECOMMENDS THIS PRODUCT TO BE INSTALLED BY A LICENSED ELECTRICIAN.

Figure 1

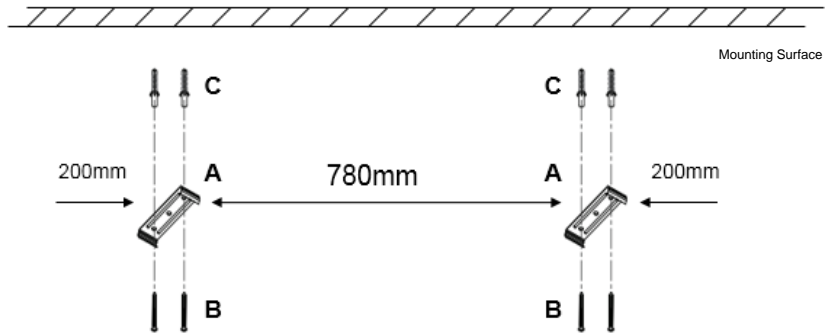
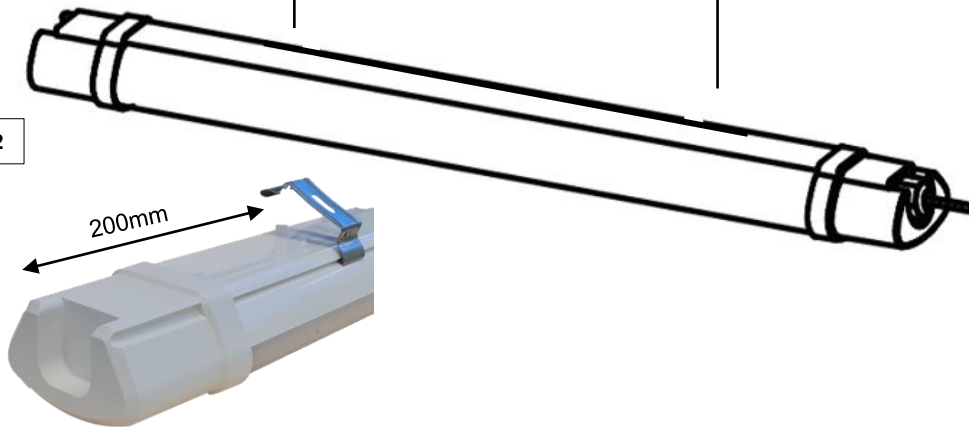

Figure 2



Installation Instructions for ESSENTIAL IP65 TRI PROOF 36W LED BATTEN:

Prior to Installation of the LED BATTEN a Surface mount power socket must be installed on or near mounting surface by a Licensed Electrician.

1. Ensure mains power supply is switched OFF at mains switchboard.
2. Unpack the fixture and accessories carefully and place on a flat surface. Dispose all packaging material thoughtfully.
3. Using Screws (B) Rawl plugs (C) Secure the mounting brackets (A) to mounting surface. Spread brackets (A) 780mm apart, with each bracket 200mm approx. from each end cap of batten (Figure 1)
4. Attach the fixture onto the mounting brackets (A) by sliding one side of the base onto the bracket, then pushing the other side on firmly (Figure 2). Check fitting is firmly secured and will not come loose.
5. Plug into surface mount power socket. (Figure 3) Check plug is firmly secured.
6. Return power to the mains switchboard.
7. Turn on light at wall switch.



ESSENTIAL IP65 TRI PROOF 36W LED BATTEN

Model No	21794/05
Wattage	36W

ALTHOUGH THIS FITTING IS 'DIY - DO IT YOURSELF', BRILLIANT LIGHTING RECOMMENDS THIS PRODUCT TO BE INSTALLED BY A LICENSED ELECTRICIAN.

Warranty:

Brilliant Lighting warrants this product against defects in manufacture and workmanship for a period of 2 years from date of purchase. This warranty is only valid for products installed and operated within the guidelines specified by Brilliant Lighting, and within the correct operating voltage ranges as stated on the product's rating label.

Warranty does not include damage or loss arising from incorrect installation, operation or maintenance of this product, damage caused through modification, incorrect installation, service by unqualified or unauthorised personnel or lack of regular maintenance and cleaning. Proof of installation by qualified personnel may be required, e.g. Electrical Safety Certificate. Proof of purchase must be supplied with all warranty claims.

This warranty is provided in addition to any other rights and remedies of the customer under any law. In applications not intended for household, personal or domestic use, liability is limited to replacement or reimbursement of product only. Brilliant Lighting does not warranty the costs of removal or re-installation of this product or associated components.

Our goods come with guarantees that cannot be excluded under the Australian Consumer Law. You are entitled to a replacement or refund for a major failure and compensation for any other reasonably foreseeable loss or damage. You are also entitled to have the goods repaired or replaced if goods fail to be of acceptable quality and the failure does not amount to a major failure.

Any claim under this warranty must be made within the specified warranty period from date of purchase of this product. To make a claim under the warranty; at your own expense take the product (with proof of purchase – receipt or similar) to the store where you purchased the product or contact Brilliant Lighting at the address below

This warranty is given by:

Brilliant Lighting (Aust) Pty. Ltd.

ABN 37 006 203 694

956 Stud Road Rowville, VIC 3178

Phone: 03 9765 2555

Email: warranty@brilliantlighting.com.au

www.brilliantlighting.com.au