

UNIVERSAL ELECTRIC POWER WINDOW REGULATOR UPGRADE KIT FOR FLAT GLASS

SKU# U552-0003S - Package Contents: (2) Window Regulators w/motor, (1) Wiring Harness & Switch Kit, (1) Installation Instructions
(1) Hardware Kit

THANK YOU for purchasing our window regulator kit for flat glass. These power window kits are designed as a DIY upgrade for mechanical windows and will only work for vehicles with FLAT window glass and will not work in doors with CURVED glass. As these are a universal kit designed to fit a variety of vehicles, these instructions are to be used as a general guide.

We have included additional hardware that we found through our experience to be helpful. The (6) bolts with metal spacers can be used to position the regulators away from the door panel while the (2) bolts with nylon spacers can be attached to the regulator rail to fabricate a glass stop.

MOUNTING THE POWER WINDOW REGULATOR ASSEMBLY

THE REGULATORS ARE INTERCHANGEABLE LEFT OR RIGHT - please determine your best usage prior to installation

1. Center the track (A) and mount it straight up and down inside the door panel - DIAGRAM 1

- The interior of the door will need to be no less than 20" tall for the regulator to fit inside.
- There should be at least 1" of clearance between the glass and the inside of the door to mount the regulator.
- The interior of the door must be at least 2" wide to accommodate the motor
- When the window is in the up position the glass must fully extend 1-1.5" into the door to attach to the regulator.
- If the glass is too short, new glass will need to be cut.
- Allow for full travel of glass inside the door without obstruction.

2. Install glass (D) into glass guide (E) - DIAGRAM 2

- Loosen bolts 1 and 2 as well as bolts 3 and 4 on glass guide (E).
- Carefully slide glass in between rubber in clamps and secure by tightening bolts 1 and 2.
- **For proper adjustment it is recommended to snug bolts 3 and 4 then apply 12V power to the motor to ensure correct travel of the glass in the channel without binding.**
- Tighten bolts 3 and 4 with glass fully at the top and re-test.

3. Mount the motor (B) to the door panel - DIAGRAM 1

- Use existing holes or drill new holes as indicated on the included MOTOR MOUNTING TEMPLATE.
- Use caution when locating the motor. The plastic tube (C) has some flexibility but avoid excess stress on it.

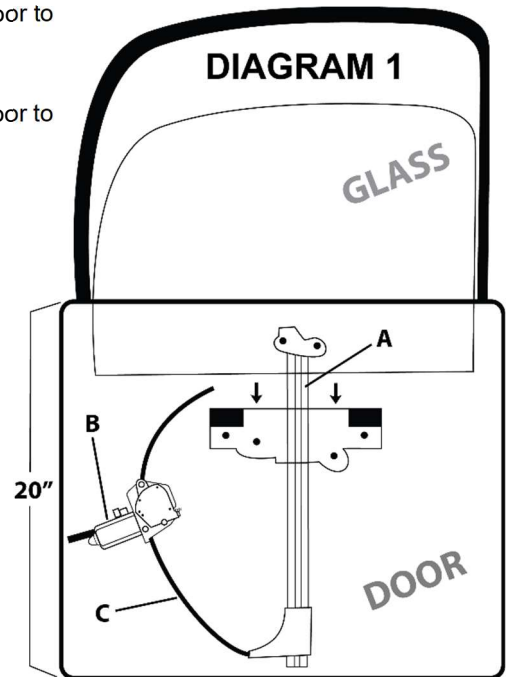

DIAGRAM 1

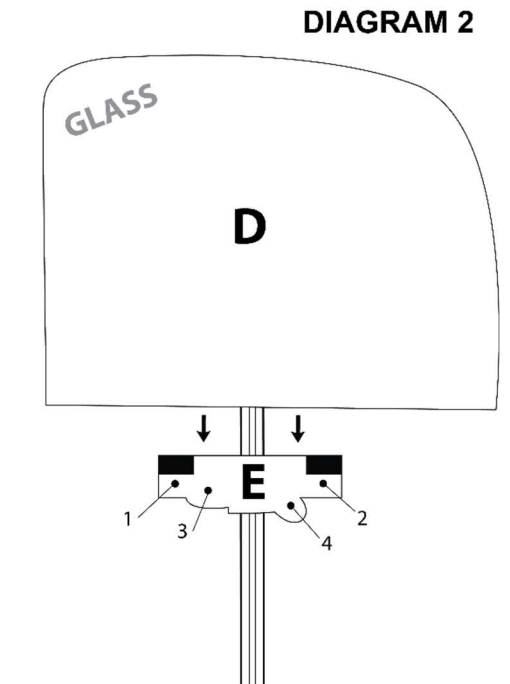
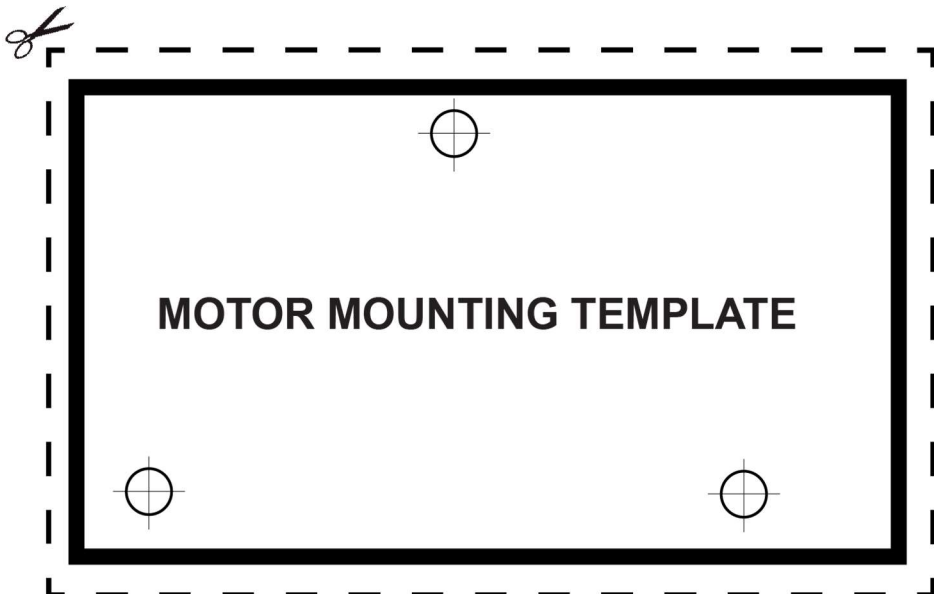

DIAGRAM 2



WIRING

ALL WIRING IS PLUG AND PLAY USING THE INCLUDED HARNESES AND SWITCHES

THE MAIN HARNESS CONNECTORS to the SWITCH HARNESS CONNECTORS have been INTENTIONALLY left off to allow for easier installation through the door jamb and door. Reference DIAGRAM 3 for placement in the included connectors.

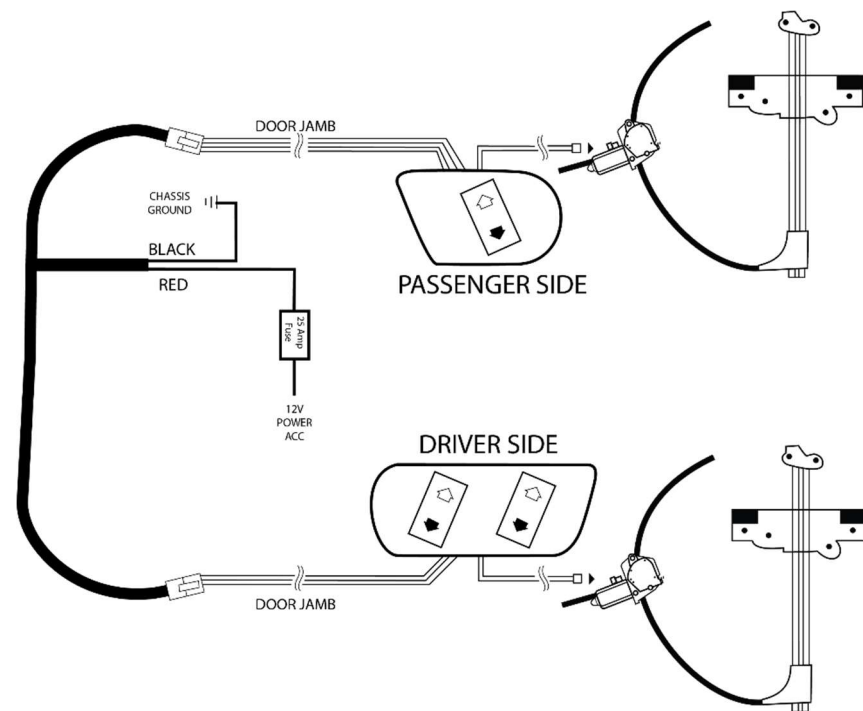
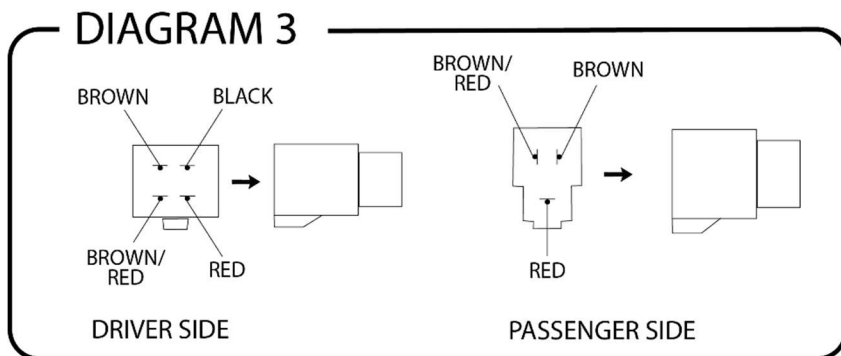

1. Secure the main wire harness to the underside of the dash with the 4 wires to the driver's door and the 3 wires to the passenger's door.
2. Run the wiring through the door jamb and into the door using the existing loom if available. **HOLES MAY NEED TO BE DRILLED.**
3. Mount the switches as desired using the included templates.
4. Connect the switches and motors to the main harness ensuring that it is clear of all moving components.
5. Connect the RED power wire on the main harness to a 12V power source preferably to the keyed ACC. **switched source allows for windows to operate only with the key in the ON position.**
6. Connect the BLACK ground wire on the main harness to a clean chassis ground point.
7. Turn ignition to ON position and test operation of the windows.



BrockSupply.com