

SKU# U552-0002S



ELECTRIC WINDOWS REGULATOR

NOTE: Before proceeding with the installation, follow carefully the instructions. Installation should only be undertaken by experienced staff.

- Our product has been conceived following standard rules of use; but we can sum up the following necessary installation conditions, that can be used for most the vehicles. Remove door handle and door trim; check if our mechanism can be inserted inside (see point 2 of the installation instructions).
- After having removed the door handle ensure there is at least 12 mm of the window shaft extending beyond the level of the door skin. If not, carefully follow the installation instructions in order to find a possible solution.
- The maximum effort our mechanism is designed to withstand is 3 Kg. Applied at a distance of 70 mm from the centre. This effort is enough for most vehicles. If you have any doubts or if the vehicles has a particularly heavy control, we advise you to check the weight.
- Before fitting, please check that the mechanical door parts function correctly and, if necessary, gre ase the channels or replace the faulty parts. Please also note that if the manual device is noisy. It will be necessary to eliminate the noise before commencing the installation as the noise will increase with the electric device.

INSTRUCTION MANUAL

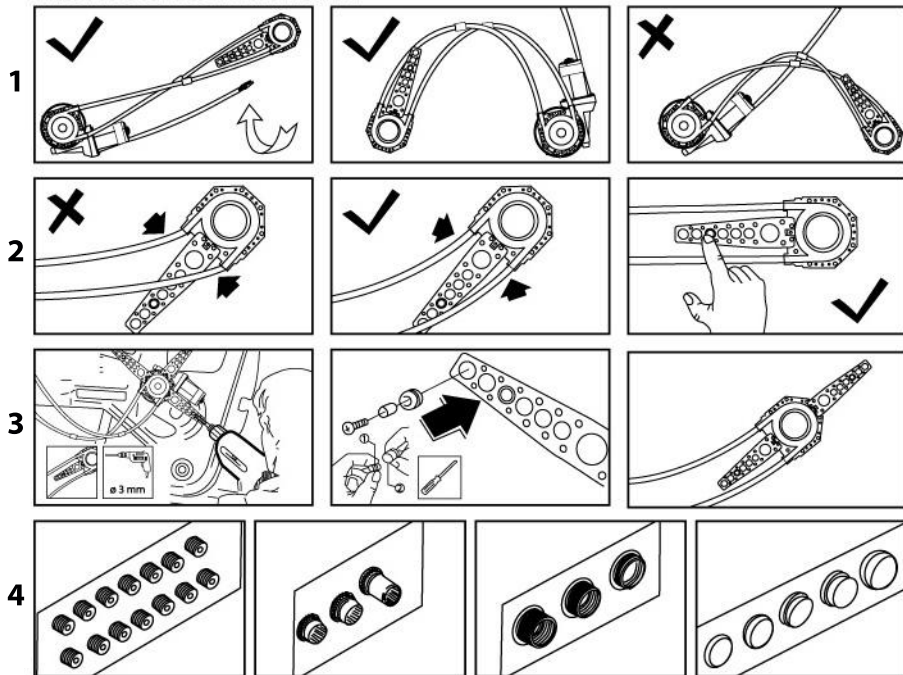

- Lower the window.
- Remove the window handle.
- Apply on the panel the adhesive template for the centring of the pivot as shown in the picture.
- Remove the door panel.
- Detach carefully the outside protective cover.

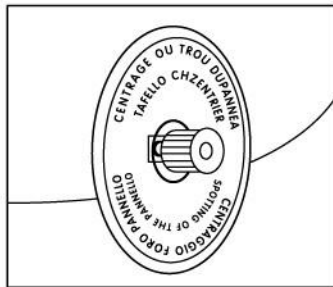
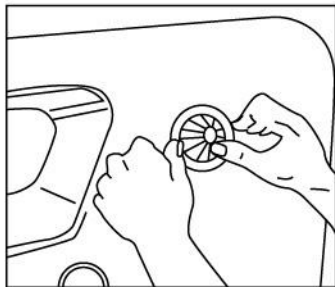
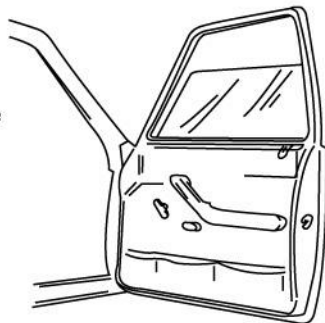

- Find the assembling position of the driving gear.
- Check which driving gear (there are two driving gears which are symmetric), is more suitable for the door. The reducer will be placed outside the panel.
- During the positioning you might require some adapters on the door in order to obtain the minimum protrusion of the reducer from the panel (see point A).
- During the fixing of the reducer or of the motor you might require the mounting bracket supplied.

POINT A
POINT A
PUNKT A
PARTICOLARE A
DIBUJO A

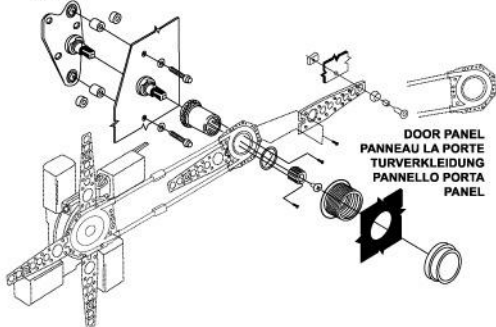

DOOR PANEL
PANNEAU LA PORTE
TURVERKLEIDUNG
PANNELLO PORTA
PANEL

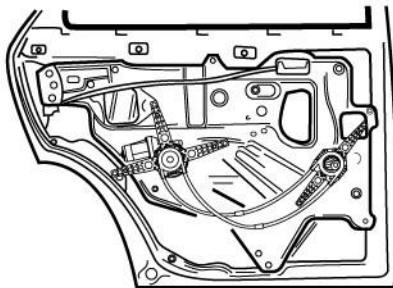

Choose the right adapter following the table mount it on the handle pivot.
 In case the handle is fixed with the screw, use the screw again to fix the adapter.
 Choose the gear sleeve according to the table below.
 Mount it on the reducer and fix it with the grommet supplied in the kit n. 1.

ADAPTERS TABLE

N. 1: ALFA ROMEO / AUTOBIANCHI BEDFORD / DAF / DATSUN FIAT / FORD (CEE) / LANCIA MERCEDES / NISSAN / OPEL PORSCHE / SAAB / SUBARU VOLKSWAGEN	N. 4: AUSTIN / ROVER N. 5: VAUXALL / JAGUAR BEDFORD / ROVER N. 6: FORD (UK)	N. 9: HONDA N. 10: MAZDA / FORD (U.S.A.) N. 11: ISUZU
N. 2: ARO / CITROEN / PEUGEOT RENAULT / SEAT / TALBOT	N. 7: OPEL	N. 12: FORD (U.S.A.)
N. 3: AUDI / BMW / FIAT / VOLVO FORD (CEE) / PORSCHE VOLKSWAGENN.	N. 8: DAIHATSU / MITSUBISHI TOYOTA / SUZUKI / G. M CHEVROLET / PONTIAC	N. 13: DODGE / CHRISLER

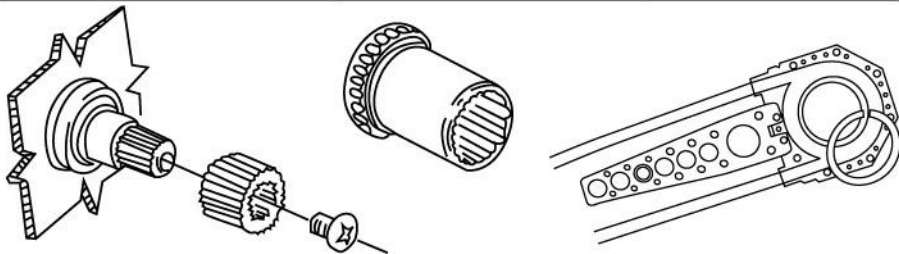

Find the right position on the door where to fix the motor.

NOTE: You must locate and fix first the motor, then insert the gear sleeve on the handle pivot.

- If necessary it is possible to change the position removing the screws, rotating the motor as shown in the picture and rescrewing in the required position.
- Insert the reducer with the gear sleeve so that the two cavities coincide and fix with the screw 2 supplied in the kit n. 1.
- Before mounting the gear sleeve, check the functioning of the emergency door handle.
- Then mount the middle gear sleeve so that the two cavities coincide and fix with the screw 2 supplied in the kit n. 1.

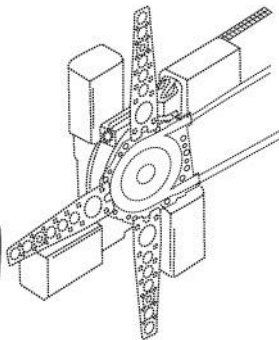
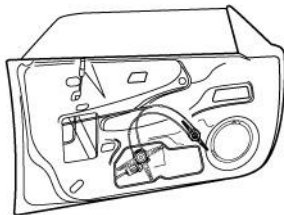
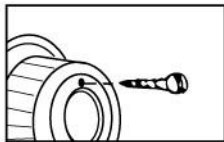
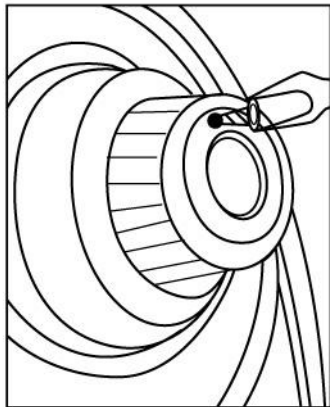

Mounting of the grommet on the inside panel.

If necessary widen then hole in the panel.

Choose the appropriate grommet, insert it into the door casing and fix with the retainer ring.

Choose the most appropriate cap (the lowest) and mount it on the grommet.

Fix the cap on the grommet and fit the panel on the door.

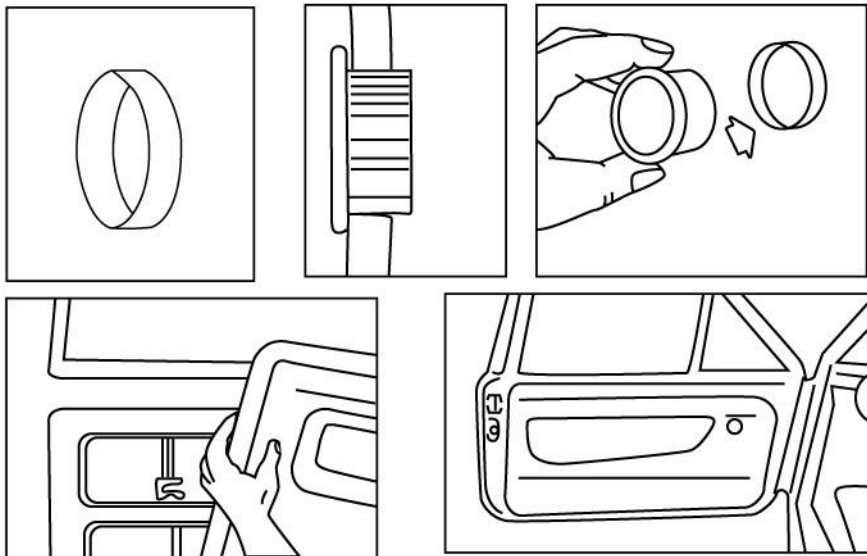

DESCRIPTION	QTY	MARK
1 ELECTRIC WINDOW L	1	
1 ELECTRIC WINDOW R	1	
2 CAPS	2	
3 CIRCLIP	2	
4 RETAINER RING	2	
5 SPEED NUT	4	
6 SPACERS	1	
7 ADAPTORS	2	
8 GEARS	2	
9 BRACKET	8	
10 RUBBER BUSH	8	
11 METAL BUSH	8	
12 SCREW 4X16	20	
13 SCREW 3X5	22	



BrockSupply.com