

ONE  NCEPT

Beef Butler

Holzkohlegrill
Charcoal Grill
Parrilla de carbón
Gril au charbon de bois
Griglia a carbone di legna

10021771

Sehr geehrter Kunde,

wir gratulieren Ihnen zum Erwerb Ihres Gerätes. Lesen Sie die folgenden Hinweise sorgfältig durch und befolgen Sie diese, um möglichen Schäden vorzubeugen. Für Schäden, die durch Missachtung der Hinweise und unsachgemäßen Gebrauch entstehen, übernehmen wir keine Haftung. Scannen Sie den folgenden QR-Code, um Zugriff auf die aktuellste Bedienungsanleitung und weitere Informationen rund um das Produkt zu erhalten:



INHALTSVERZEICHNIS

Sicherheitshinweise 4
Geräteübersicht 6
Zubehör 7
Zusammenbau 8

English 15
Español 27
Français 39
Italiano 51

HERSTELLER & IMPORTEUR (UK)

Hersteller:

Chal-Tec GmbH, Wallstraße 16, 10179 Berlin, Deutschland.

Importeur für Großbritannien:

Berlin Brands Group UK Ltd
PO Box 1145
Oxford, OX1 9UW
United Kingdom

SICHERHEITSHINWEISE



WARNUNG

Erstickungsgefahr! Der Hoolzkohlegrill ist nur zur Nutzung im Freien bestimmt. Er darf nicht in Gebäuden, Garagen oder anderen geschlossenen Bereichen verwendet werden. Es können sich giftige Dämpfe bilden, die zum Ersticken führen.

- Stellen Sie den Grill immer auf eine feste, ebene und hitzebeständige Oberfläche, in ausreichender Entfernung von Zäunen, überhängenden Ästen und anderen brennbaren Stoffen.
- Der Grill muss stets von einer sachkundigen erwachsenen Person überwacht werden.
- Verwenden Sie nur Anzündhilfen entsprechend EN 1860-3. Verwenden Sie zum Anzünden des Grills nie Brennspritus, Paraffinöl, Methylalkohol, Benzin oder ähnliche Lösungsmittel. Verwenden Sie zum Anzünden einen geeigneten Flüssiganzünder und befolgen Sie dabei die Herstellerhinweise. Fügen Sie keinen Flüssiganzünder mehr hinzu, wenn die Kohle brennt.
- Die meisten Teile aus Metall werden heiß. Tragen Sie Schutzhandschuhe, wenn Sie den Grill berühren oder das Grillgut wenden. Der Grill darf während des Betriebes nicht bewegt werden.
- Wenn Fett auf die Kohle tropft, kommt es zum Aufflammen. Halten Sie einen fein eingestellten Wassersprüher bereit, um solche Flammen zu löschen und das Verbrennen des Grillguts zu verhindern.
- Wenn das Grillen beendet ist, löschen Sie die Kohle mit einem feinen Sprühnebel ab oder bedecken die Kohle mit Sand.
- Stellen Sie sicher, dass der Grill vollständig abgekühlt ist, bevor Sie ihn bewegen und die Asche leeren.
- Verlängern Sie die Lebenszeit der Metallteile, indem Sie den Grill nicht ungeschützt im Freien stehen lassen. Idealerweise sollte der Grill in einer Garage oder einem Gartenschuppen aufbewahrt werden, wenn er nicht gebraucht wird.
- Legen Sie das Grillgut erst auf, wenn der Brennstoff mit einer Ascheschicht bedeckt ist!
- Halten Sie Kinder und Tiere vom Gerät fern.

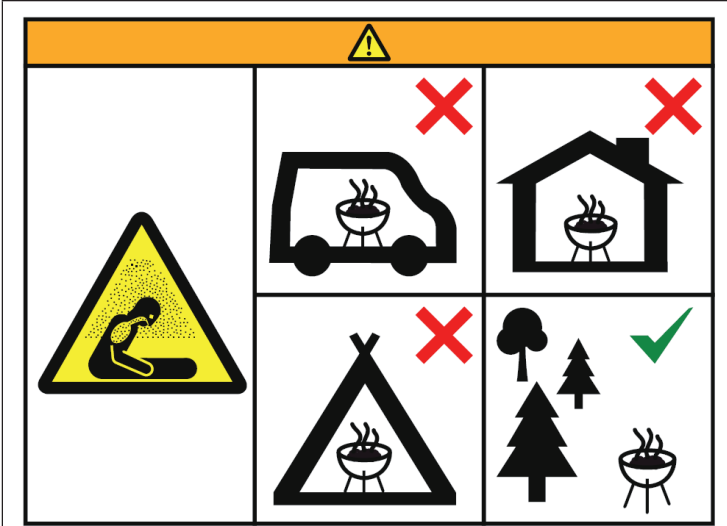

VORSICHT!

VERWENDEN SIE KEINEN ALKOHOL
ODER BENZIN ZUM ANZÜNDEN ODER
WIEDERANZÜNDEN!

GERÄTEÜBERSICHT

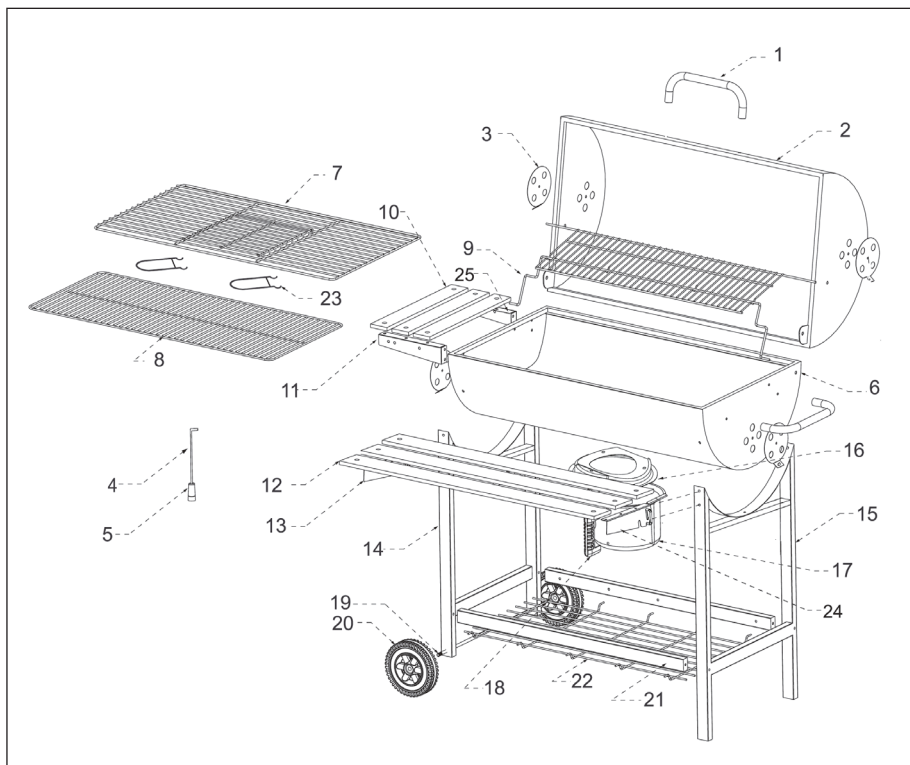











Hinweis: Überprüfen Sie den Lieferumfang auf Vollständigkeit hin, bevor Sie den Grill zusammensetzen. Obwohl der Hersteller jede Anstrengung unternommen hat, scharfe Kanten vom Grill zu entfernen, müssen Sie mit allen Teilen vorsichtig umgehen, um Verletzungen zu vermeiden.

ZUBEHÖR

Nr.	Bezeichnung	Stk.	Nr.	Bezeichnung	Stk.
1	Griff	2	13	Stütze für vordere Ablage	2
2	Deckel	1	14	Kurzes Standbein	1
3	Luftöffnung	4	15	Langes Standbein	1
4	Entlüftungsstange	1	16	Verbindungsstück	1
5	Holzgriff	1	17	Aschebehälter	1
6	Feuerwanne	1	18	Bakelitgriff	1
7	Grillrost	1	19	Achse	1
8	Kohlerost	1	20	Rad	2
9	Warmhalterost	1	21	Metallstrebe	2
10	Seitenablagebrett	3	22	Drahtrost	1
11	Stütze für Seitenablage	2	23	Rost-Griff	2
12	Vordere Ablage	3	24	Stütze für vordere Ablage	1
			25	Stütze für Seitenablage	1

Schrauben und andere Montageteile

Nr.	Bezeichnung		Stk.	Nr.	Bezeichnung		Stk.
A		M6x16mm	2	H		M6	8
B		M5x10mm	11	I		M5	23
C		M5x20mm	12	J		M8	2
D		M6x25mm	10	K		Scheiben	2
E		M6x35mm	4				
F		M6x60mm	4				

ZUSAMMENBAU

Hinweis: Ziehen Sie die Schrauben nicht fest, bevor Sie den Grill zusammengebaut haben.

1

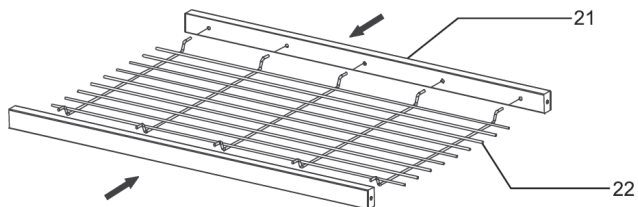

Führen Sie die Enden des Drahrosts (22) in die passenden Löcher der Metallstrebe (21) ein.

2

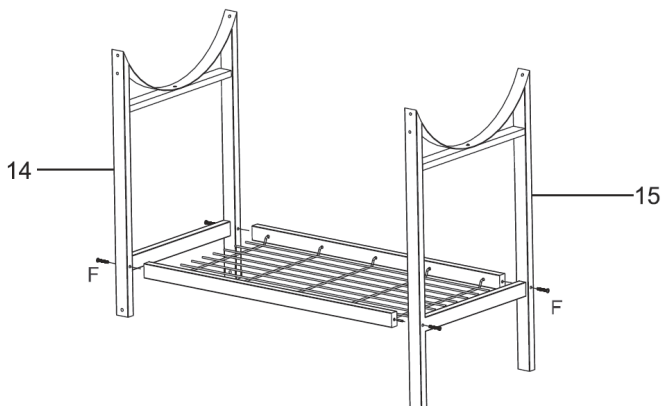

Befestigen Sie das kurze Bein (14) mit 2 Schrauben (F) an einer Seite der Metallstrebe. Befestigen Sie das lange Bein (15) mit 2 Schrauben (F) an der anderen Seite der Metallstrebe (21).

3

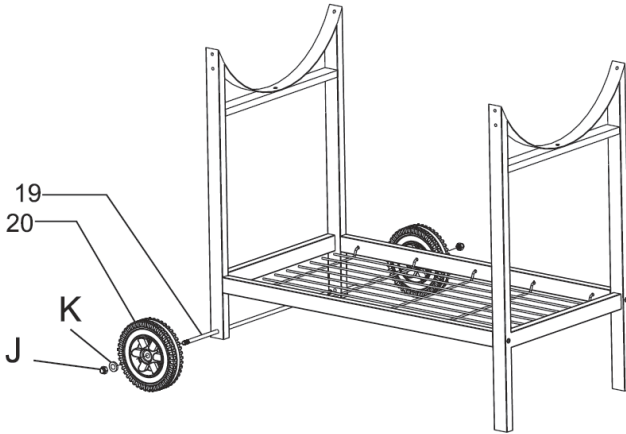

Stecken Sie die Achse (19) durch die Löcher des kurzen Beins (14) und befestigen Sie die Räder (20) an beiden Seiten der Achse. Befestigen Sie die Unterlegscheibe (K) an beiden Enden der Achse und ziehen Sie sie mit 2 M8-Muttern (J) fest.

4

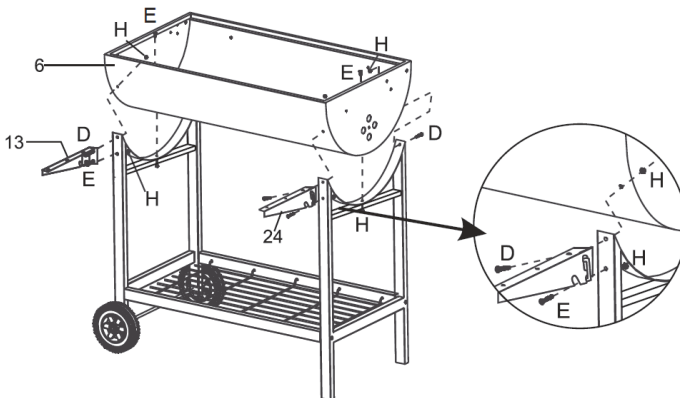

Befestigen Sie die Feuerwanne (6) und die Stütze für die vordere Ablage (13 & 24) mit 4 Schrauben (D), 4 Stück Schrauben (E) und 8 M6-Muttern (H) an den Beinen.

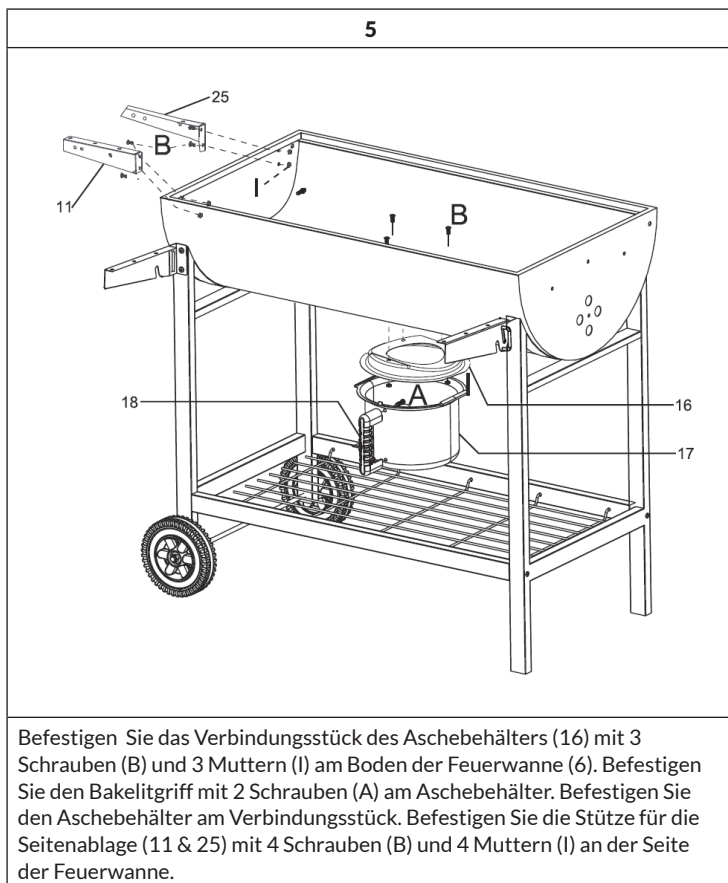

6

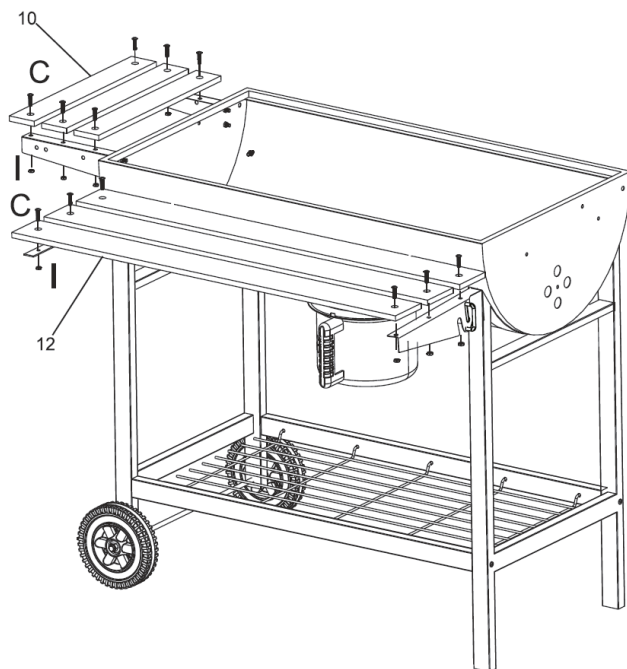

Befestigen Sie die Holzteile der vorderen Ablage (12) mit 6 Schrauben (C) und 6 Muttern (I) an der Stütze für die vordere Ablage (13). Legen Sie die Seitenablagebretter (10) auf die Stützen für Seitenablagen (11) und befestigen Sie sie mit 6 Schrauben (C) und 6 Muttern (I).

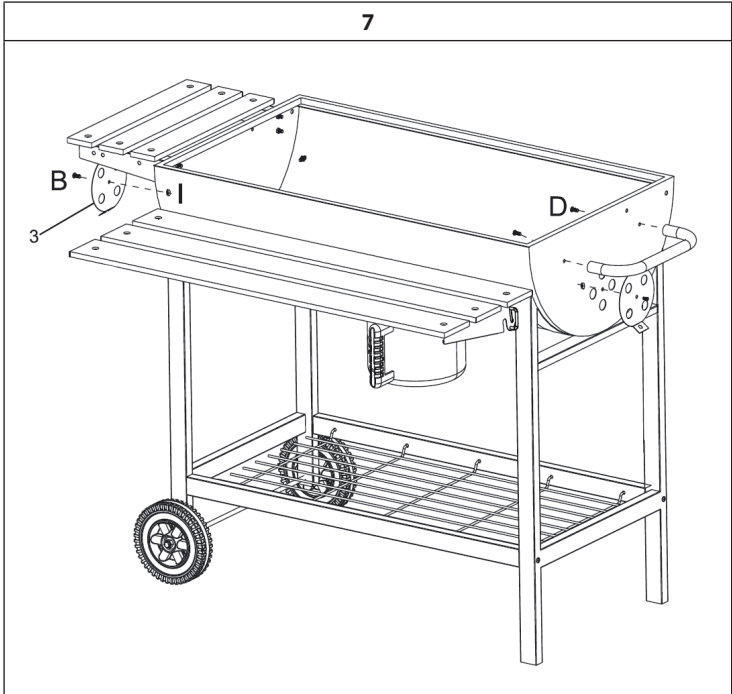

Befestigen Sie den Griff (1) mit 2 Schrauben (D) an der Seite der Feuerwanne. Befestigen Sie die Luftöffnungen (3) mit 2 Schrauben (B) und 2 Muttern (I) an der Seite der Feuerwanne.

8

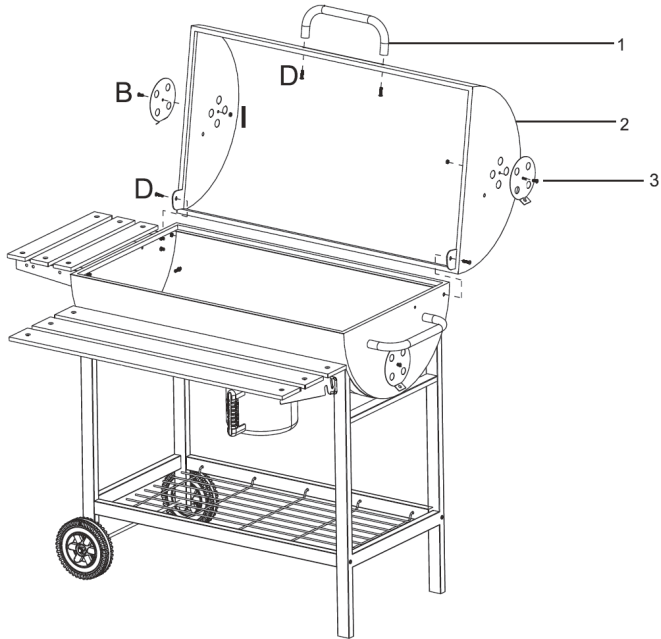

Setzen Sie den Deckel (2) auf die Feuerwanne (6). Richten Sie die Gewindebohrung hinten am Deckel an den Bohrungen der Feuerwanne aus und befestigen Sie den Deckel mit 2 Schrauben (D). Befestigen sie dann die Luftöffnungen (3) mit 2 Schrauben (B) und 2 Muttern (I) an der Seite des Deckels. Befestigen Sie den Metallgriff (1) mit 2 Schrauben (D) an der Vorderseite des Deckels.

9

Wenn alle Teile vollständig montiert sind, ziehen Sie alle Schrauben und Muttern fest. Legen Sie den Kohlerost (8) in die Feuerwanne. Legen Sie den Grillrost (7) auf die Feuerwanne und befestigen Sie den Warmhalterost zwischen Deckel und Feuerwanne. Befestigen Sie zum Schluss die Rost-Griffe (23) am Grillrost.

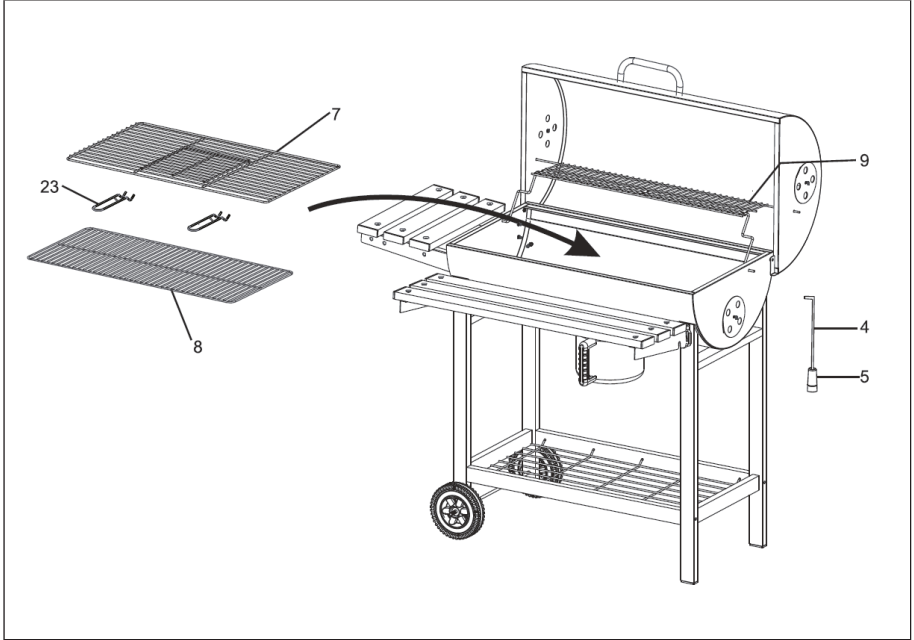

Dear customer,

Congratulations on the purchase of your appliance. Please read the following instructions carefully and follow them to prevent potential damage. We accept no liability for damage caused by disregarding the instructions or improper use. Please scan the QR code to access the latest operating instructions and for further information about the product.



CONTENTS

Safety instructions 16
Device overview 18
Accessories 19
Assembly 20

MANUFACTURER & IMPORTER (UK)

Manufacturer:

Chal-Tec GmbH, Wallstraße 16, 10179 Berlin, Germany.

Importer for Great Britain:

Berlin Brands Group UK Ltd
PO Box 1145
Oxford, OX1 9UW
United Kingdom

SAFETY INSTRUCTIONS

**WARNING**

Risk of suffocation! The charcoal grill is only intended for outdoor use. It must not be used in buildings, garages or other enclosed areas. Toxic fumes can form, which lead to suffocation.

- Always place the grill on a firm, level and heat-resistant surface, away from fences, overhanging branches and other flammable materials.
- The grill must always be supervised by a knowledgeable adult.
- Only use ignition aids in accordance with EN 1860-3. Never use denatured alcohol, paraffin oil, methyl alcohol, gasoline or similar solvents to light the grill. Use a suitable liquid lighter for lighting and follow the manufacturer's instructions. Stop adding a liquid lighter when the charcoal is burning.
- Most metal parts get hot. Wear protective gloves when touching the grill or turning the food. The grill must not be moved during operation.
- If fat drips on the charcoal, it will flare up. Have a finely adjusted water sprayer ready to put out such flames and prevent the food from burning.
- When the grilling is finished, extinguish the charcoal with a fine spray or cover the charcoal with sand.
- Make sure the grill is completely cool before moving it or emptying the ashes.
- Extend the life of the metal parts by not leaving the grill unprotected outdoors. Ideally, the grill should be stored in a garage or garden shed when not in use.
- Do not place the food on the grill until the fuel is covered with a layer of ash!
- Keep children and animals away from the device.

		
	 ✗	 ✗
	 ✗	 ✓

CAUTION!
DO NOT USE ALCOHOL OR GASOLINE TO
LIGHT OR RE-LIGHT!

DEVICE OVERVIEW

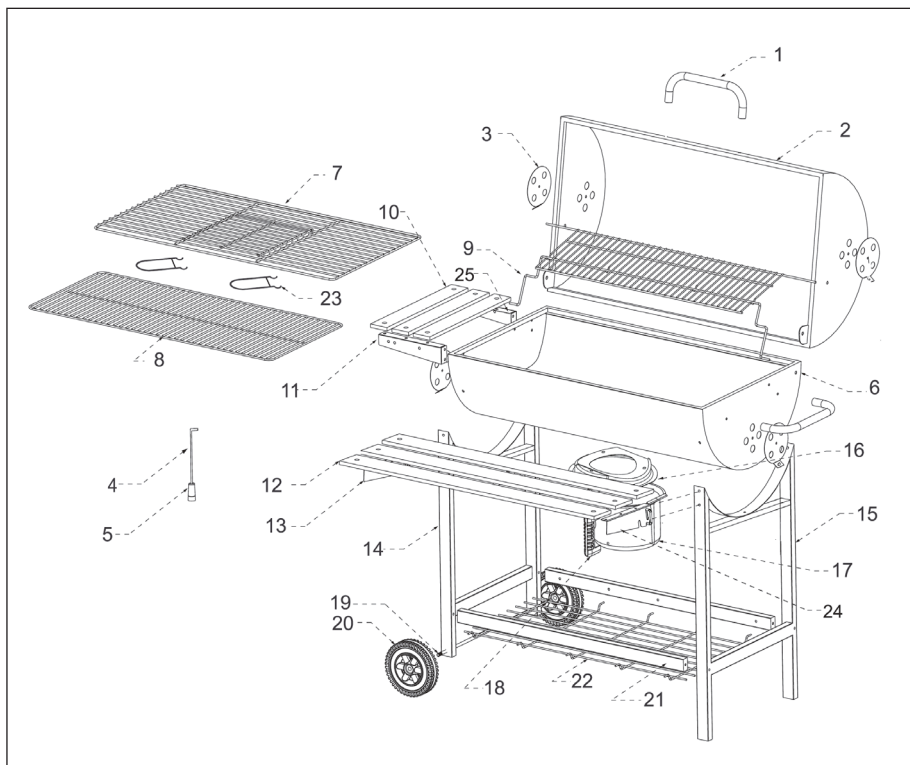











Note: Check the scope of delivery for completeness before assembling the grill. Although the manufacturer has made every effort to remove sharp edges from the grill, care must be taken with all parts to avoid injury.

ACCESSORIES

No.	Designation	Pc.	No.	Designation	Pc.
1	Handle	2	13	Front shelf support	2
2	Cover	1	14	Short standing leg	1
3	Air vent	4	15	Long standing leg	1
4	Hook for	1	16	Connector	1
5	Wood handle	1	17	Ash container	1
6	Fire tray	1	18	Plastic handle	1
7	Grill grate	1	19	Axle	1
8	Charcoal grate	1	20	Wheel	2
9	Warming rack	1	21	Metal brace	2
10	Side shelf	3	22	Wire grate	1
11	Support for side shelf	2	23	Grate handle	2
12	Front shelf	3	24	Front shelf support	1
			25	Support for side shelf	1

Screws and other assembly parts

No.	Designation		Pc.	No.	Designation		Pc.
A		M6x16mm	2	H		M6	8
B		M5x10mm	11	I		M5	23
C		M5x20mm	12	J		M8	2
D		M6x25mm	10	K		Washer	2
E		M6x35mm	4				
F		M6x60mm	4				

ASSEMBLY

Note: Do not tighten the screws until you have assembled the grill.

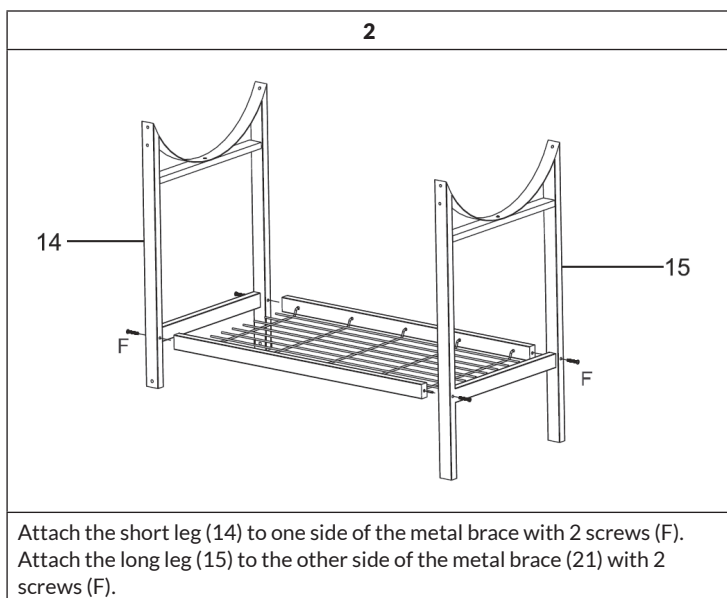
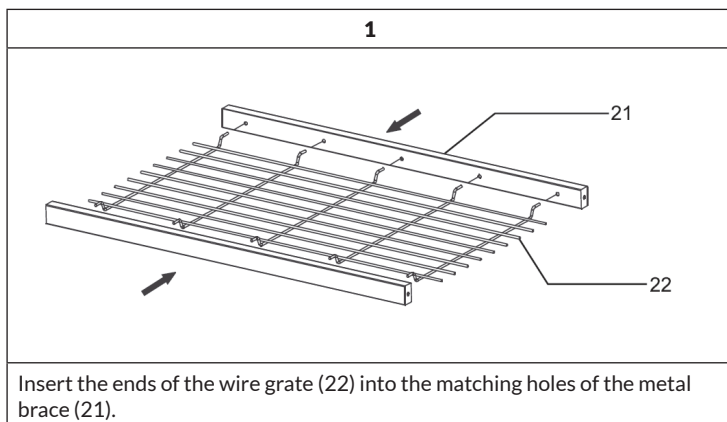

3

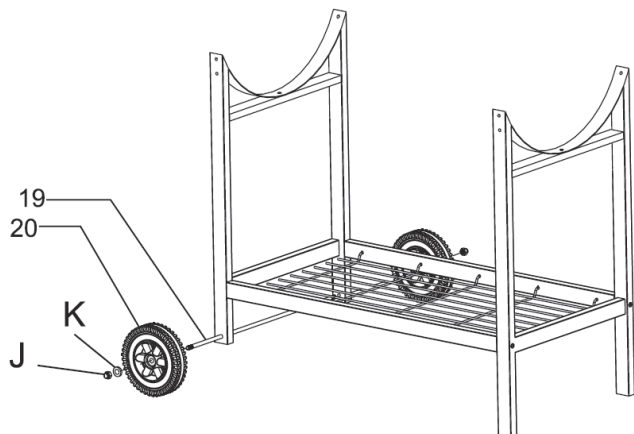

Insert the axle (19) through the holes of the short leg (14) and attach the wheels (20) to both sides of the axle. Attach the washer (K) to both ends of the axle and tighten with 2 M8 nuts (J).

4

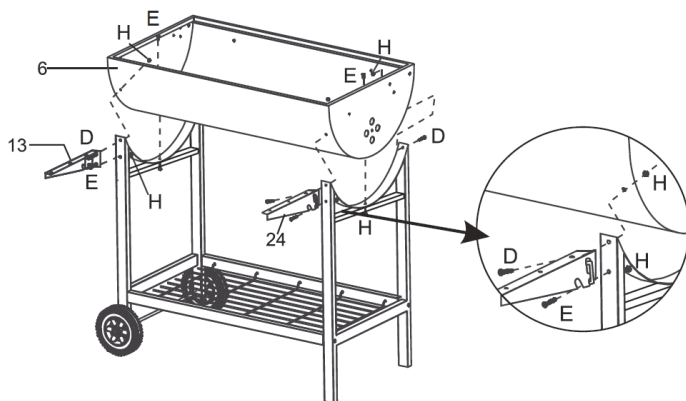

Attach the fire tray (6) and the front shelf support (13 & 24) to the legs using 4 screws (D), 4 pieces of bolts (E) and 8 M6 nuts (H).

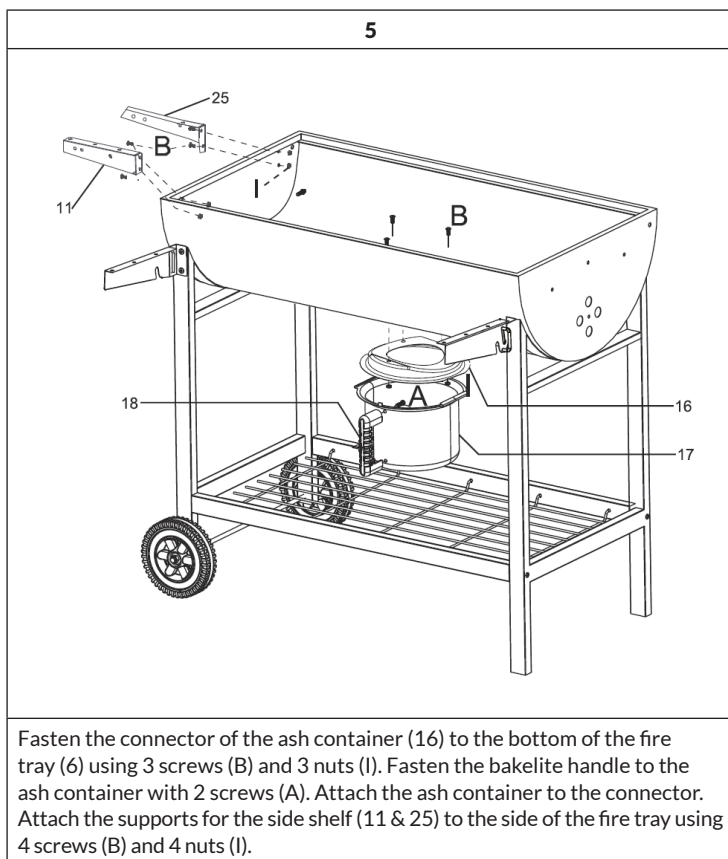

6

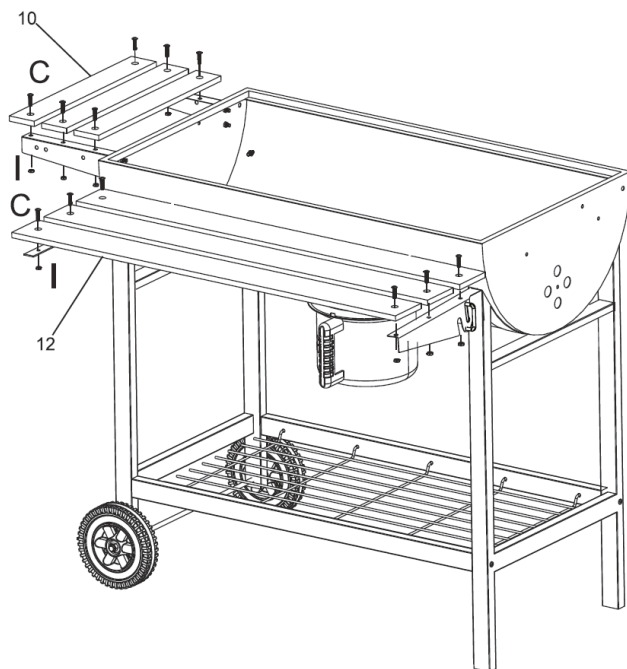

Attach the wooden parts of the front shelf (12) to the front shelf support (13) using 6 screws (C) and 6 nuts (I). Place the side shelves (10) on the side shelf supports (11) and fasten them with 6 screws (C) and 6 nuts (I).

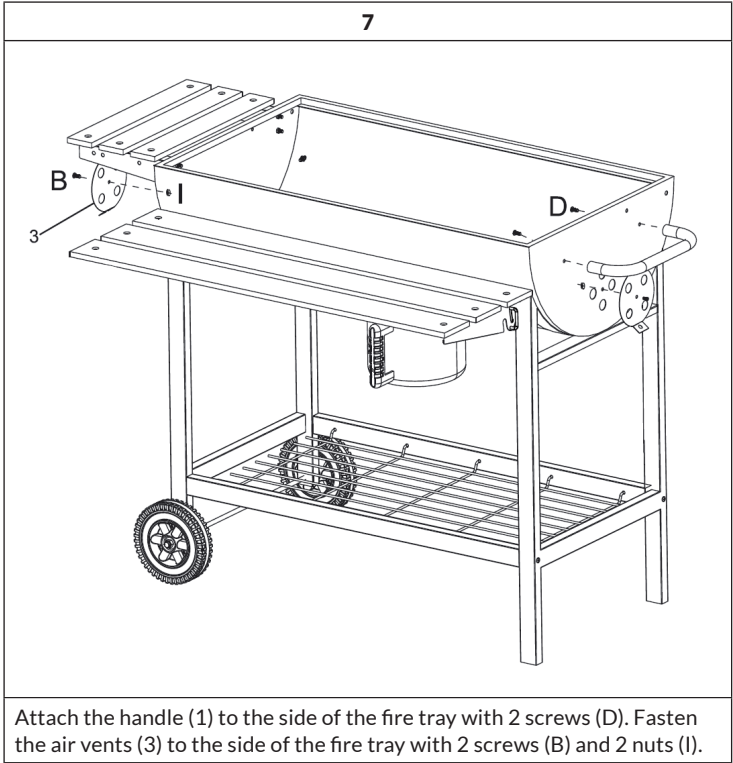

8

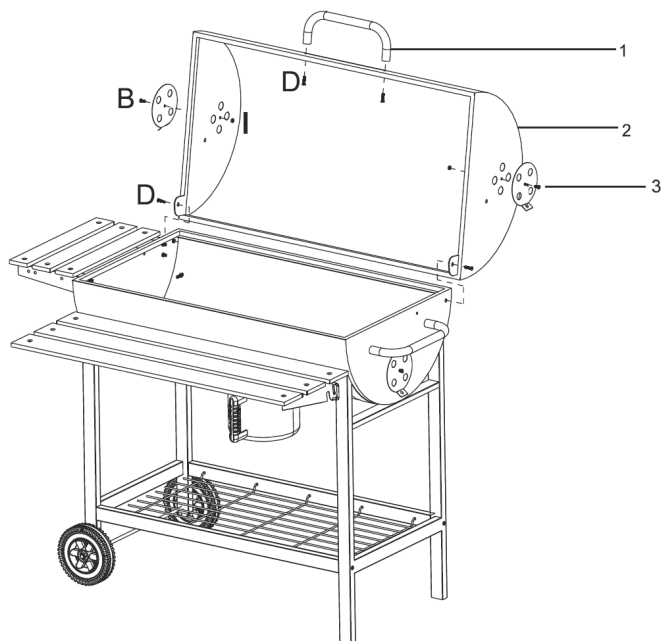

Place the cover (2) on the fire tray (6). Align the threaded hole at the back of the lid with the holes in the fire tray and secure the lid with 2 screws (D). Then fasten the air vents (3) to the side of the lid with 2 screws (B) and 2 nuts (I). Attach the metal handle (1) to the front of the lid with 2 screws (D).

9

When all parts are fully assembled, tighten all screws and nuts. Place the charcoal grate (8) in the fire tray. Place the grill grate (7) on the fire tray and attach the warming rack between the lid and the fire tray. Finally, attach the grate handles (23) to the grate.

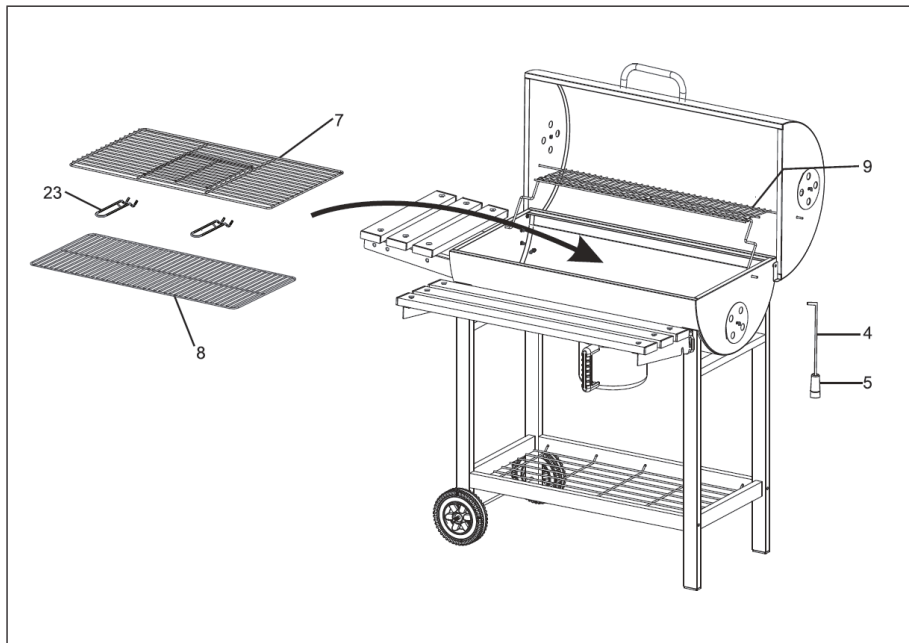

Estimado cliente:

Le felicitamos por la adquisición de este producto. Lea atentamente el siguiente manual y siga cuidadosamente las instrucciones de uso con el fin de evitar posibles daños. La empresa no se responsabiliza de los daños ocasionados por un uso indebido del producto o por haber desatendido las indicaciones de seguridad. Escanee el siguiente código QR para obtener acceso al manual de usuario más reciente y otra información sobre el producto.



ÍNDICE

Indicaciones de seguridad 28
Vista general del aparato 30
Accesorios 31
Montaje 32
Sommaire 39
Fabricant et importateur (GB) 39

FABRICANTE E IMPORTADOR (RU)

IMPORTADOR:

Chal-Tec GmbH, Wallstraße 16, 10179 Berlín, Alemania.

Importador para el Reino Unido:

Chal-Tec UK limited.
Unit 6 Riverside Business Centre
Brighton Road
Shoreham-by-Sea
BN43 6RE
Reino Unido

INDICACIONES DE SEGURIDAD



ADVERTENCIA

¡Peligro de asfixia! La barbacoa de carbón está pensada únicamente para su uso en el exterior. No debe utilizarse en interiores, en garajes u otros espacios cerrados. Se pueden formar humos tóxicos que pueden causar asfixia.

- Coloque siempre la barbacoa sobre una superficie resistente al calor, sólida y plana, a suficiente distancia de vallas, ramas suspendidas y otro material inflamable.
- La barbacoa siempre debe estar controlada por una persona adulta y capacitada.
- Utilice solamente medios auxiliares de ignición conforme a la norma EN1860-3. Para encender la barbacoa, nunca utilice bebidas alcohólicas, aceite de parafina, alcohol etílico, gasolina ni solventes similares. Para encender la barbacoa, utilice un encendedor líquido adecuado y siga las indicaciones del fabricante. No añada ningún otro encendedor líquido cuando el carbón esté ardiendo.
- La mayoría de las partes metálicas se calentarán mucho. Utilice guantes protectores para tocar la barbacoa o voltear los alimentos. La barbacoa no debe moverse durante su funcionamiento.
- Si se cae grasa al carbón, pueden producirse llamas. Tenga a mano un pulverizador de agua para sofocar esas llamas y evitar que se quemen los alimentos.
- Cuando finalice la cocción, apague el carbón con una pulverización de niebla fina o cúbralo con arena.
- Asegúrese de que la barbacoa se haya enfriado por completo antes de moverla o de vaciar las cenizas.
- Prolongue la vida útil de las piezas metálicas no dejando la barbacoa sin proteger al aire libre. En el caso ideal, la barbacoa debería guardarse en un garaje o cobertizo de jardín cuando no se utilice.
- Coloque los alimentos solo cuando el carbón esté cubierto con una capa de cenizas.
- Mantenga a los niños y mascotas alejados del aparato.

		
	 ✗	 ✗
	 ✗	 ✓

¡ATENCIÓN!
¡NO UTILICE ALCOHOL O GASOLINA PARA
ENCENDER O REENCENDER!

VISTA GENERAL DEL APARATO

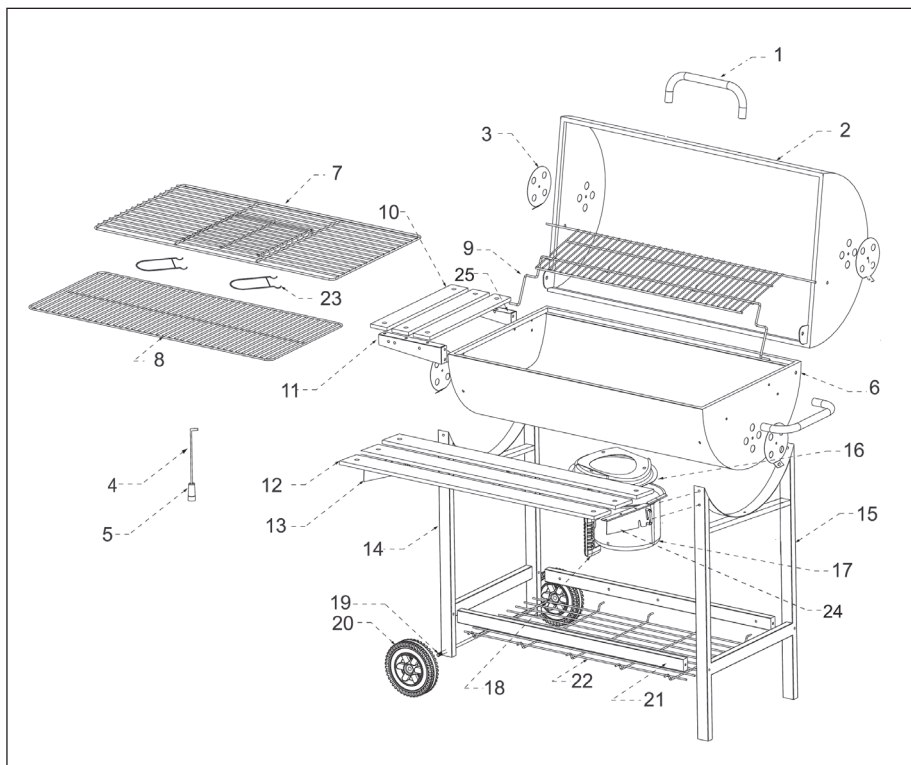











Nota: compruebe que el suministro del envío esté completo antes de montar la barbacoa. Aunque el fabricante se haya esforzado por eliminar los cantos afilados de la barbacoa, debe manipular las piezas con cuidado para evitar lesiones.

ACCESORIOS

Núm.	Descripción	Uds.	Núm.	Descripción	Uds.
1	Asa	2	13	Soporte para balda delantera	2
2	Tapa	1	14	Pata corta	1
3	Orificio de ventilación	4	15	Pata larga	1
4	Varilla de ventilación	1	16	Conector	1
5	Mango de madera	1	17	Recipiente para las cenizas	1
6	Recipiente de combustión	1	18	Mango de baquelita	1
7	Parrilla	1	19	Eje	1
8	Rejilla para el carbón	1	20	Rueda	2
9	Rejilla de mantenimiento de calor	1	21	Puntal metálico	2
10	Tabla de la balda lateral	3	22	Rejilla de alambre	1
11	Soporte para la balda lateral	2	23	Mango de la parrilla	2
12	Balda delantera	3	24	Soporte para balda delantera	1
			25	Soporte para la balda lateral	

Tornillos y otras piezas de montaje

Núm.	Descripción		Uds.	Núm.	Descripción		Uds.
A		M6x16mm	2	H		M6	8
B		M5x10mm	11	I		M5	23
C		M5x20mm	12	J		M8	2
D		M6x25mm	10	K		Arandelas	2
E		M6x35mm	4				
F		M6x60mm	4				

MONTAJE

Aviso: no apriete los tornillos hasta no haber montado la barbacoa.

1

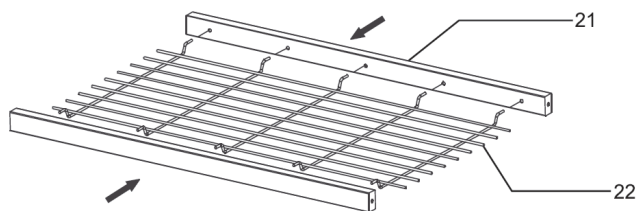

Introduzca los extremos de la rejilla de alambre (22) en los orificios adecuados del puntal metálico (21).

2

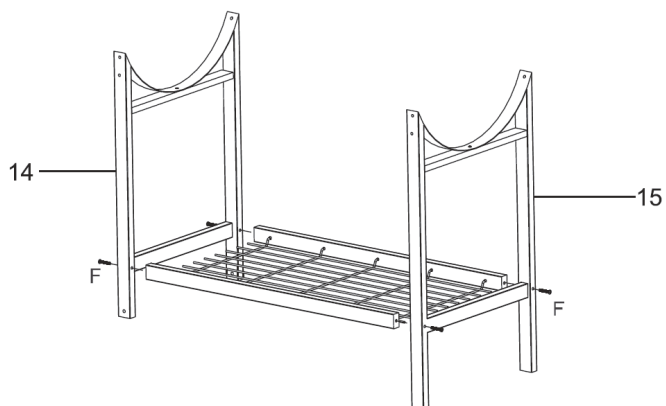

Fije la pata corta (14) con 2 tornillos (F) a un lado del puntal metálico. Fije la pata corta (15) con 2 tornillos (F) a un lado del puntal metálico (21).

3

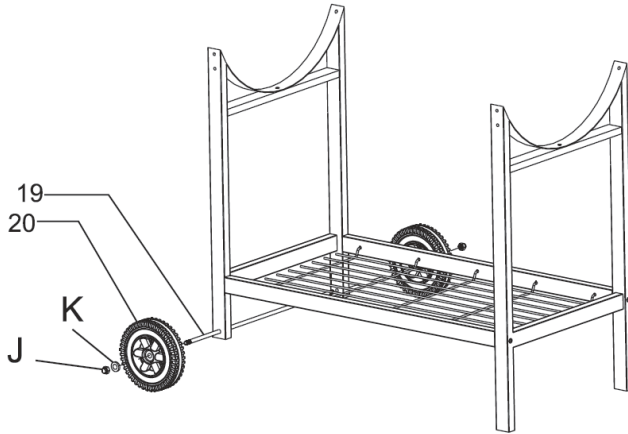

Pase el eje (19) por los agujeros de la pata corta (14) y fije las ruedas (20) a ambos lados del eje. Coloque la arandela (K) en ambos extremos del eje y apriete con 2 tuercas M8 (J).

4

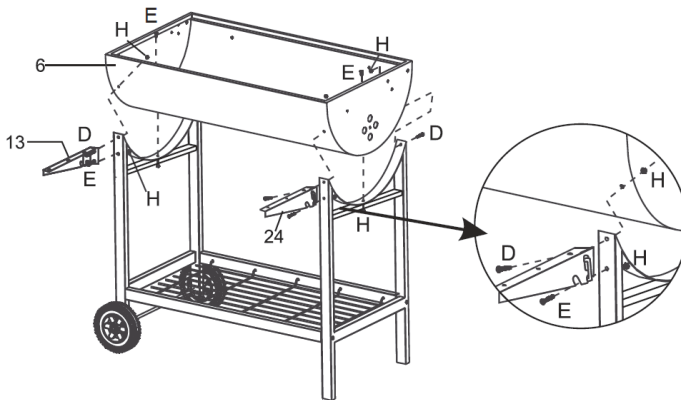

Fije la bandeja (6) y el soporte para el estante delantero (13 & 24) a las patas con 4 tornillos (D), 4 trozos de pernos (E) y 8 tuercas M6 (H).

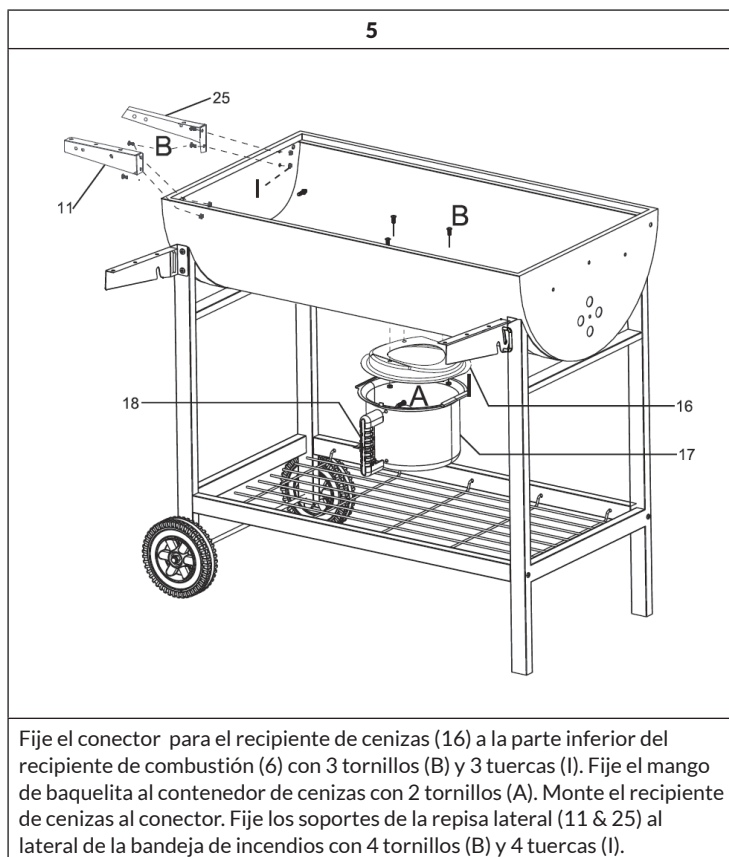

6

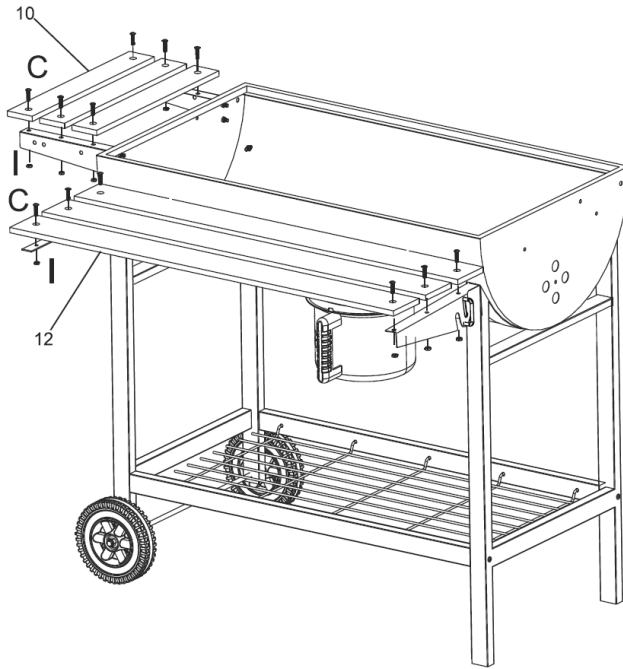

Fije las piezas de madera de la balda delantera (12) al soporte de la balda delantera (13) con 6 tornillos (C) y 6 tuercas (I). Coloque los estantes laterales (10) en los soportes de los laterales (11) y fíjelos con 6 tornillos (C) y 6 tuercas (I).

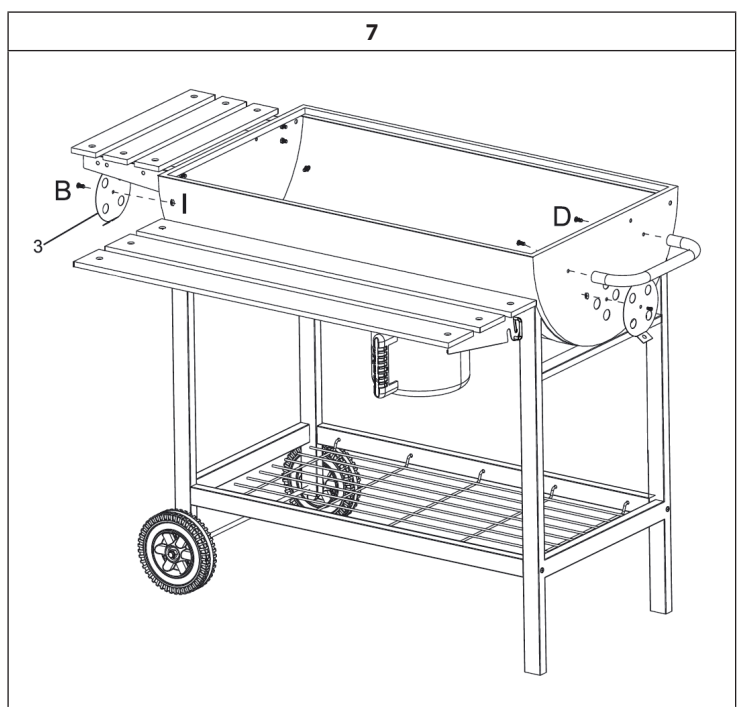

Fije el asa (1) al lateral de la bandeja de fuego con 2 tornillos (D). Fije los soportes de la repisa lateral (3) al lateral de la bandeja con 2 tornillos (B) y 2 tuercas (I).

8

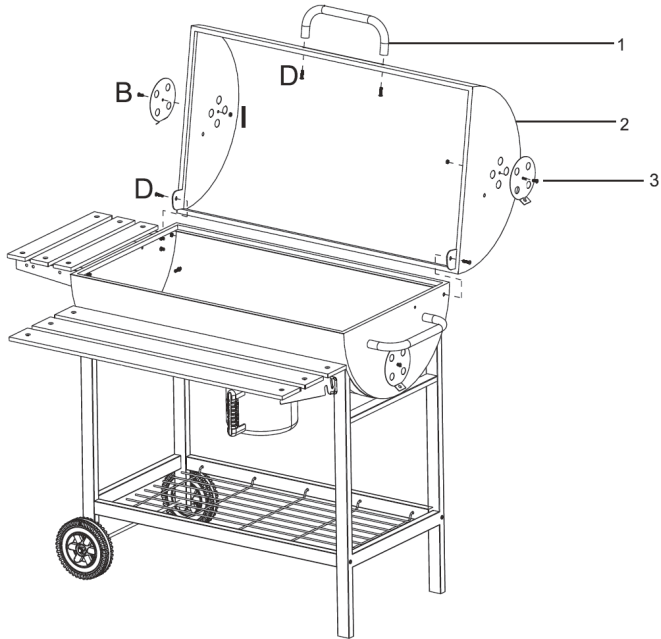

Coloque la tapa (2) en la bandeja de fuego (6). Alinee el orificio roscado de la parte posterior de la tapa con los orificios de la bandeja de fuego y fije la tapa con 2 tornillos (D). Fije los soportes de la repisa lateral (3) al lateral de la bandeja con 2 tornillos (B) y 2 tuercas (I). Fije el asa metálica (1) a la parte delantera de la tapa con 2 tornillos (D).

9

Cuando todas las piezas estén completamente montadas, apriete todos los tornillos y tuercas. Coloque la rejilla para el carbón (8) en el recipiente de combustión. Coloque la rejilla de la parrilla (7) sobre la bandeja de fuego y fije la rejilla de calentamiento entre la tapa y la bandeja de fuego. Por último, fije las asas de la parrilla (23) a la rejilla.

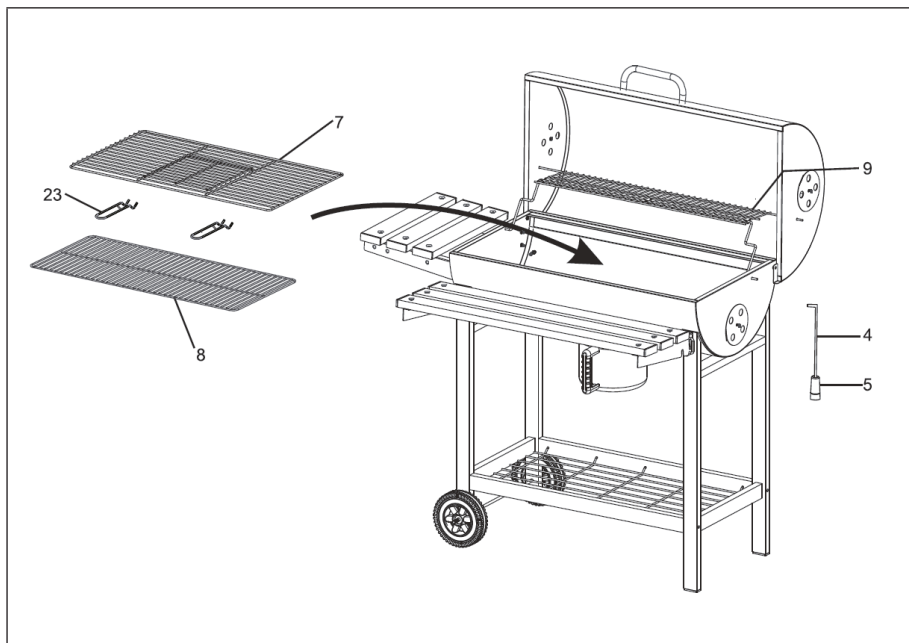

Cher client, chère cliente,

Toutes nos félicitations pour l'acquisition de ce nouvel appareil. Lisez attentivement les indications suivantes et suivez-les pour éviter d'éventuels dommages. Nous ne saurions être tenus pour responsables des dommages dus au non-respect des consignes et à la mauvaise utilisation de l'appareil. Scannez le QR-Code pour obtenir la dernière version du mode d'emploi ainsi que d'autres informations concernant le produit :



SOMMAIRE

Consignes de sécurité 40
Aperçu de l'appareil 42
Accessoires 43
Assemblage 44

FABRICANT ET IMPORTATEUR (GB)

Fabricant :

Chal-Tec GmbH, Wallstraße 16, 10179 Berlin, Allemagne.

Importateur pour la Grande Bretagne :

Chal-Tec UK limited
Unit 6 Riverside Business Centre
Brighton Road
Shoreham-by-Sea
BN43 6RE
Royaume Uni

CONSIGNES DE SÉCURITÉ



MISE EN GARDE

Risque d'étouffement ! Le barbecue au charbon est uniquement destiné à une utilisation en extérieur. Il ne doit pas être utilisé dans un bâtiment, un garage ou d'autres espaces clos. Des fumées toxiques peuvent se former et provoquer un étouffement.

- Placez toujours le barbecue sur une surface ferme, plane et résistante à la chaleur, loin des clôtures, des branches en surplomb et d'autres matériaux inflammables.
- Le barbecue doit toujours être surveillé par un adulte compétent.
- Utiliser uniquement des aides à l'allumage conformes à la norme EN 1860-3. N'utilisez jamais d'alcool dénaturé, d'huile de paraffine, d'alcool méthylique, d'essence ou de solvants similaires pour allumer le barbecue. Utilisez un allume feu liquide approprié et suivez les instructions du fabricant. Arrêtez d'ajouter de l'allume-feu liquide lorsque le charbon de bois brûle.
- La plupart des pièces métalliques deviennent chaudes. Portez des gants de protection lorsque vous touchez le barbecue ou retournez les aliments. Le barbecue ne doit pas être déplacé pendant le fonctionnement.
- Si de la graisse coule sur le charbon de bois, il s'enflammera. Préparez un pulvérisateur d'eau finement réglé pour éteindre de telles flammes et empêcher les aliments de brûler.
- Lorsque la cuisson est terminée, éteignez le charbon avec un jet fin ou recouvrez le charbon de sable.
- Assurez-vous que le barbecue est complètement froid avant de le déplacer et de vider les cendres.
- Prolongez la durée de vie des pièces métalliques en ne laissant pas le barbecue sans protection à l'extérieur. Idéalement, le barbecue doit être rangé dans un garage ou un abri de jardin lorsqu'il n'est pas utilisé.
- Ne placez pas les grillades tant que le combustible n'est pas recouvert d'une couche de cendres !
- Tenez les enfants et les animaux domestiques à distance de l'appareil.

		
	 ✗	 ✗
	 ✗	 ✓

ATTENTION !
N'UTILISEZ PAS D'ALCOOL OU D'ESSENCE
POUR ALLUMER OU RALLUMER LE FEU !

APERÇU DE L'APPAREIL

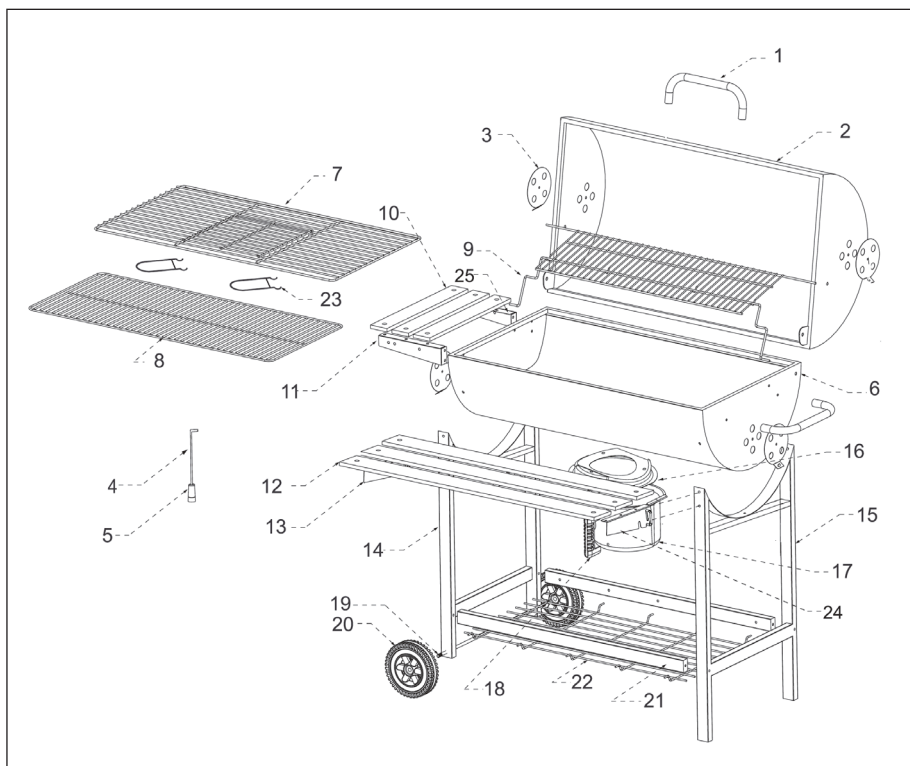











Remarque : Vérifiez que la livraison est complète avant d'assembler le barbecue. Bien que le fabricant ait fait tout son possible pour enlever les bords tranchants du barbecue, prenez des précautions avec toutes les pièces pour éviter les blessures.

ACCESSOIRES

N°	Description	Qté	N°	Description	Qté
1	Poignée	2	13	Support de tablette avant	2
2	Couvercle	1	14	Pied court	1
3	Ouverture de ventilation	4	15	Pied long	1
4	Tige d'aération	1	16	Pièce de raccordement	1
5	Poignée en bois	1	17	Bac à cendres	1
6	Foyer	1	18	Poignée en bakélite	1
7	Grille de cuisson	1	19	Axe	1
8	Grille de charbon de bois	1	20	Roue	2
9	Grille de maintien au chaud	1	21	Renfort en métal	2
10	Tablette latérale	3	22	Grille métallique	1
11	Support pour tablette latérale	2	23	Poignée de grille	2
12	Tablette avant	3	24	Support de tablette avant	1
			25	Support pour tablette latérale	1

Vis et autres pièces de montage

N°	Description	Qté	N°	Description	Qté
A	 M6x16mm	2	H	 M6	8
B	 M5 x 10 mm	11	I	 M5	23
C	 M5 x 20 mm	12	J	 M8	2
D	 M6 x 25 mm	10	K	 Rondelle	2
E	 M6 x 35 mm	4			
F	 M6 x 60 mm	4			

ASSEMBLAGE

Remarque ne serrez pas les vis avant la fin de l'assemblage du barbecue.

1

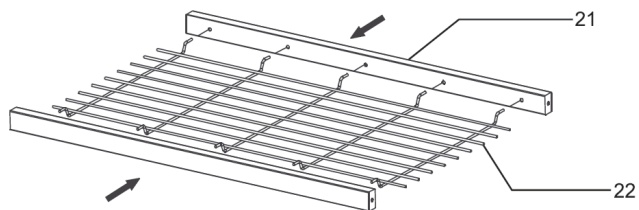

Insérez les extrémités de la grille (22) dans les trous correspondants du support métallique (21).

2

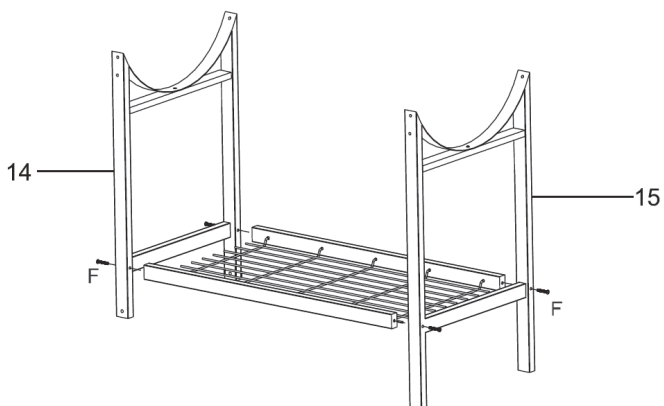

Fixez le pied court (14) avec 2 vis (F) sur un côté du support métallique. Fixez le pied long (15) avec 2 vis (F) de l'autre côté du support métallique (21).

3

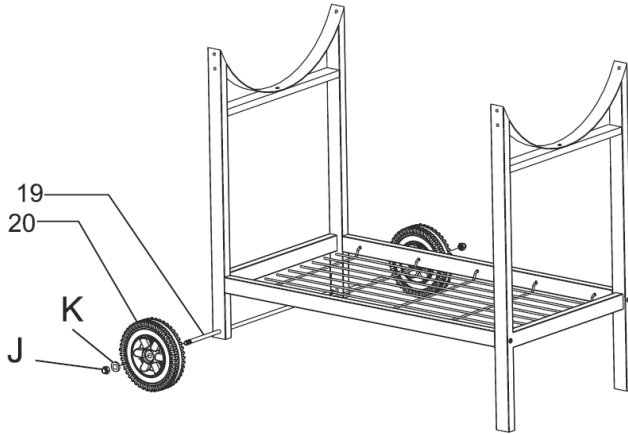

Passez l'essieu (19) dans les trous du pied court (14) et fixez les roues (20) de chaque côté de l'essieu. Fixez la rondelle (K) aux deux extrémités de l'essieu et serrez avec 2 écrous M8 (J).

4

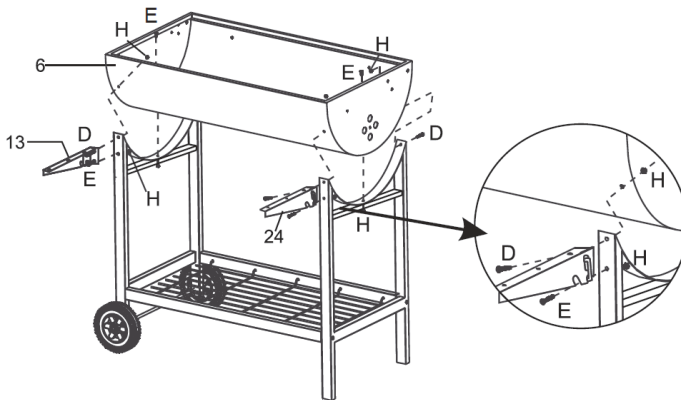

Fixez le foyer (6) et le support de la tablette avant (13 & 24) aux pieds avec 4 vis (D), 4 boulons (E) et 8 écrous M6 (H).

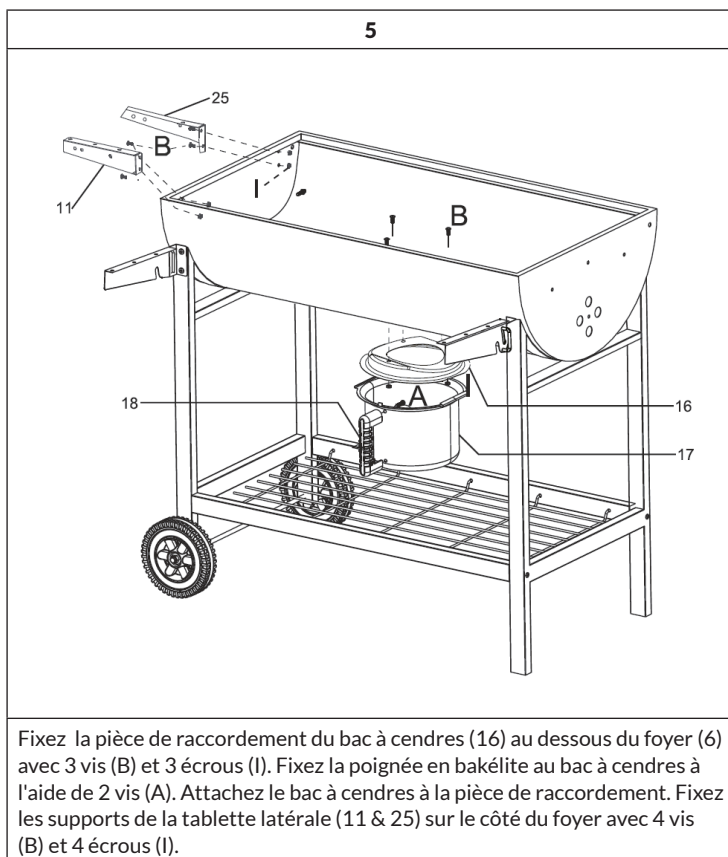

6

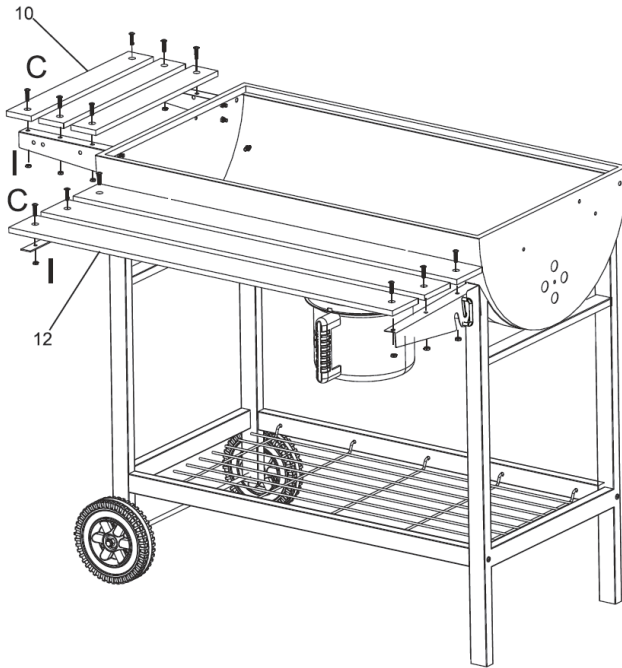

Fixez les parties en bois de la tablette avant (12) au support de la tablette avant (13) avec 6 vis (C) et 6 écrous (I). Placez les planches de la tablette latérale (10) sur leurs supports (11) et fixez-les avec 6 vis (C) et 6 écrous (I).

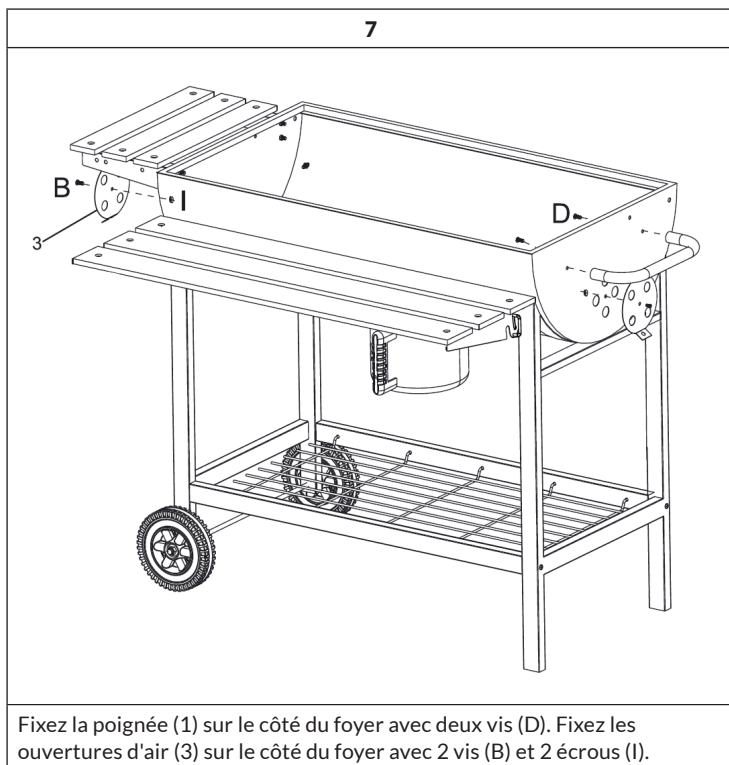

8

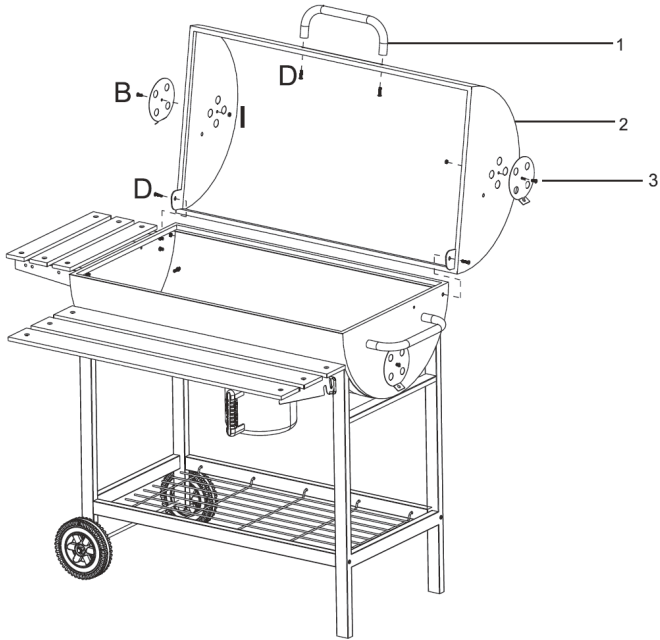

Placez le couvercle (2) sur le foyer (6). Alignez le trou fileté à l'arrière du couvercle avec les trous du foyer et fixez le couvercle avec 2 vis (D). Fixez les ouvertures d'aération (3) sur le côté du foyer avec 2 vis (B) et 2 écrous (I). Fixez la poignée métallique (1) à l'avant du foyer avec deux vis (D).

9

Lorsque toutes les pièces sont entièrement assemblées, serrez toutes les vis et tous les écrous. Placez la grille à charbon (8) dans le foyer. Placez la grille de cuisson (7) sur le foyer et fixez la grille de réchauffement entre le couvercle et le foyer. Enfin, fixez les poignées de la grille (23) à la grille de cuisson.

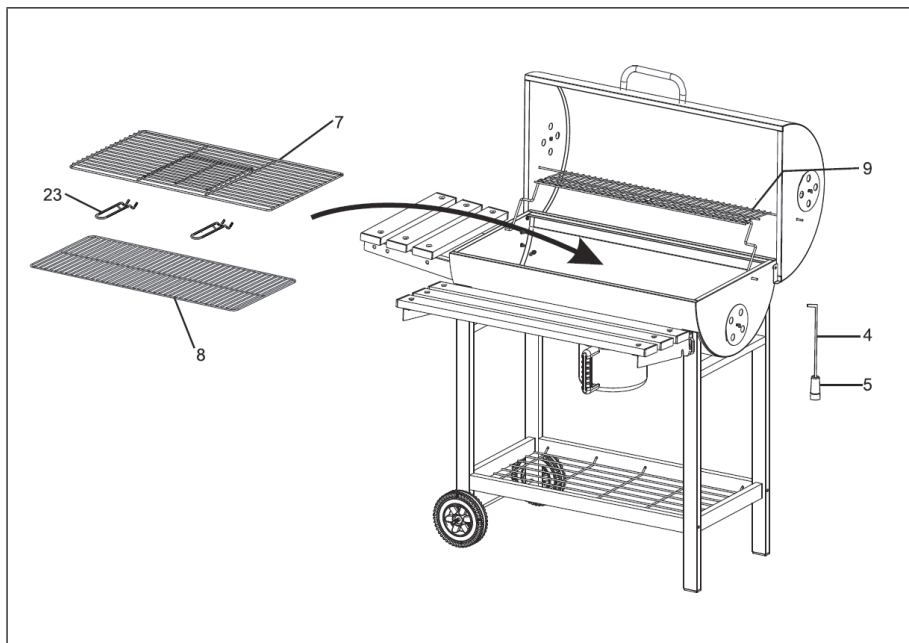

Gentile cliente,

la ringraziamo per l'acquisto del dispositivo. La preghiamo di leggere attentamente le seguenti istruzioni per l'uso e di seguirle per evitare possibili danni. Non ci assumiamo alcuna responsabilità per danni scaturiti da una mancata osservanza delle avvertenze di sicurezza e da un uso improprio del dispositivo. Scansionare il codice QR seguente per accedere al manuale d'uso più attuale e ricevere informazioni sul prodotto.



INDICE

Avvertenze di sicurezza 52
Descrizione del dispositivo 54
Accessori 55
Assemblaggio 56

PRODUTTORE E IMPORTATORE (UK)

Produttore:

Chal-Tec GmbH, Wallstraße 16, 10179 Berlino, Germania.

Importatore per la Gran Bretagna:

Chal-Tec UK limited
Unit 6 Riverside Business Centre
Brighton Road
Shoreham-by-Sea
BN43 6RE
Regno Unito

AVVERTENZE DI SICUREZZA



AVVERTIMENTO

Pericolo di soffocamento! La griglia a carbonella può essere utilizzata solo all'aperto. Non può essere utilizzato in edifici, garage o altri ambienti al chiuso. Possono formarsi vapori tossici, che provocano il soffocamento.

- Posizionare sempre la griglia su una superficie stabile, piana e resistente al calore, a distanza sufficiente da recinti, rami e altri materiali infiammabili.
- La griglia deve essere sempre tenuta sotto controllo da una persona adulta e in grado di utilizzarla in sicurezza.
- Usare solo accendifuoco conformi a EN 1860-3. Non utilizzare assolutamente spirito, olio di paraffina, metanolo, benzina o solventi simili per accendere la griglia. Utilizzare un liquido accendifuoco adatto e rispettare le indicazioni d'uso del produttore. Quando la carbonella arde, non aggiungere altro liquido accendifuoco.
- La maggior parte dei componenti metallici diventa bollente. Indossare guanti protettivi quando si tocca la griglia o si girano le pietanze. La griglia non può essere spostata durante l'uso.
- Quando il grasso gocciola sulle braci possono formarsi fiamme. Tenere un nebulizzatore con dell'acqua a portata di mano per estinguere tali fiamme ed evitare di bruciare gli alimenti.
- Al termine della cottura, spegnere le braci con il nebulizzatore o coprirle con della sabbia.
- Assicurarsi che la griglia si sia completamente raffreddata prima di spostarla o rimuovere la cenere.
- Per permettere ai componenti metallici di durare a lungo, non lasciare la griglia all'aperto senza protezione. Si consiglia di conservare la griglia in garage o capanni quando non viene utilizzata.
- Poggiare gli alimenti da grigliare solo quando la carbonella è coperta da uno strato di cenere!
- Tenere bambini e animali domestici lontano dal dispositivo.



DESCRIZIONE DEL DISPOSITIVO

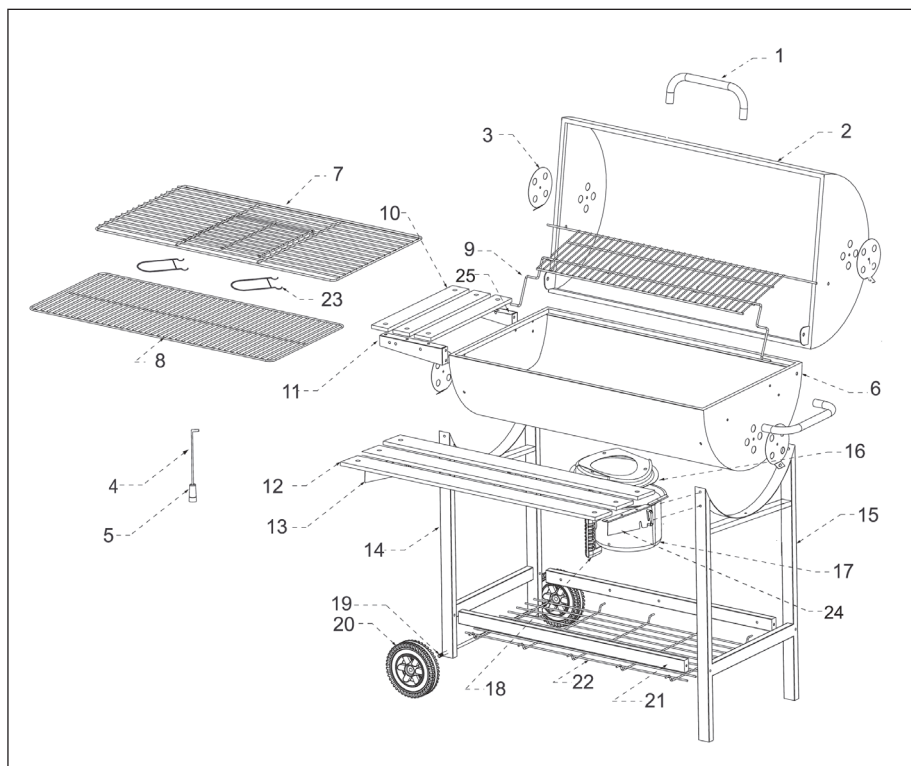











Nota: controllare che il volume di consegna sia completo prima di assemblare la griglia. Sebbene il produttore si sia impegnato al massimo per rimuovere bordi taglienti, maneggiare con attenzione i componenti per evitare lesioni.

ACCESSORI

N.	Denominazione	Pz.	N.	Denominazione	Pz.
1	Impugnatura	2	13	Supporti per l'appoggio anteriore	2
2	Coperchio	1	14	Gamba d'appoggio corta	1
3	Apertura di ventilazione	4	15	Gamba d'appoggio lunga	1
4	Asta di ventilazione	1	16	Connettore	1
5	Impugnatura di legno	1	17	Contentore per la cenere	1
6	Vasca per la carbonella	1	18	Impugnatura in bachelite	1
7	Griglia di cottura	1	19	Asse	1
8	Griglia per la carbonella	1	20	Ruota	2
9	Griglia per mantenimento calore	1	21	Montante in metallo	2
10	Piano d'appoggio laterale	3	22	Griglia in cavo metallico	1
11	Supporti per il ripiano laterale	2	23	Impugnatura per la griglia	2
12	Appoggio anteriore	3	24	Supporti per l'appoggio anteriore	1
			25	Supporti per il ripiano laterale	1

Viti e altri componenti di montaggio

N.	Denominazione		Pz.	N.	Denominazione		Pz.
A		M6x16mm	2	H		M6	8
B		M5x10mm	11	I		M5	23
C		M5x20mm	12	J		M8	2
D		M6x25mm	10	K		Rondelle	2
E		M6x35mm	4				
F		M6x60mm	4				

ASSEMBLAGGIO

Nota: non stringere completamente le viti prima di aver assemblato la griglia.

1

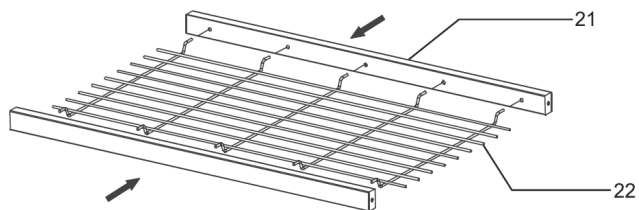

Inserire le estremità della griglia in cavo metallico (22) negli appositi fori del montante in metallo (21).

2

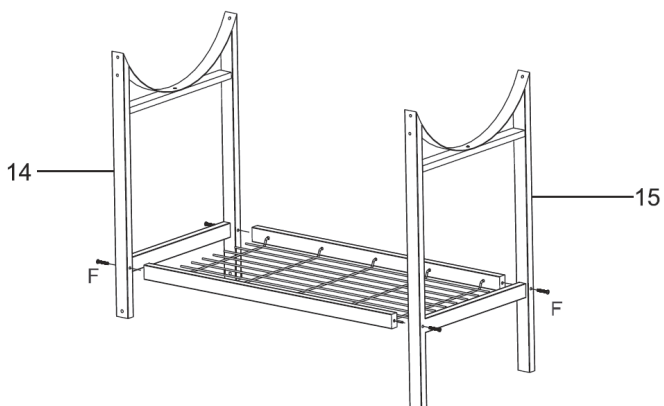

Fissare la gamba corta (14) con 2 viti (F) su un lato del montante metallico. Fissare la gamba lunga (15) con 2 viti (F) sull'altro lato del montante metallico (21).

3

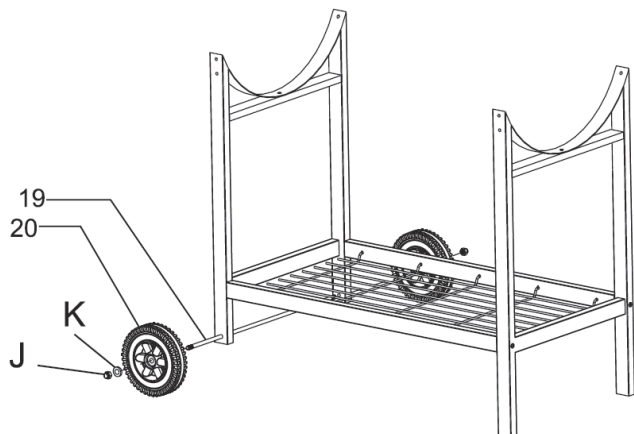

Inserire l'asse (19) attraverso i fori della gamba corta (14) e fissare le ruote (20) su entrambi i lati dell'asse. Fissare la rondella (K) a entrambe le estremità dell'asse e stringere con 2 dadi M8 (J).

4

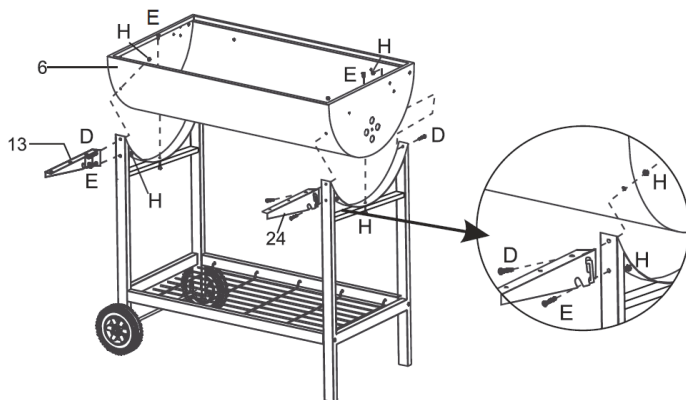

Fissare la vasca per la carbonella (6) e il supporto per il ripiano anteriore (13 & 24) alle gambe con 4 viti (D), 4 viti (E) e 8 dadi M6 (H).

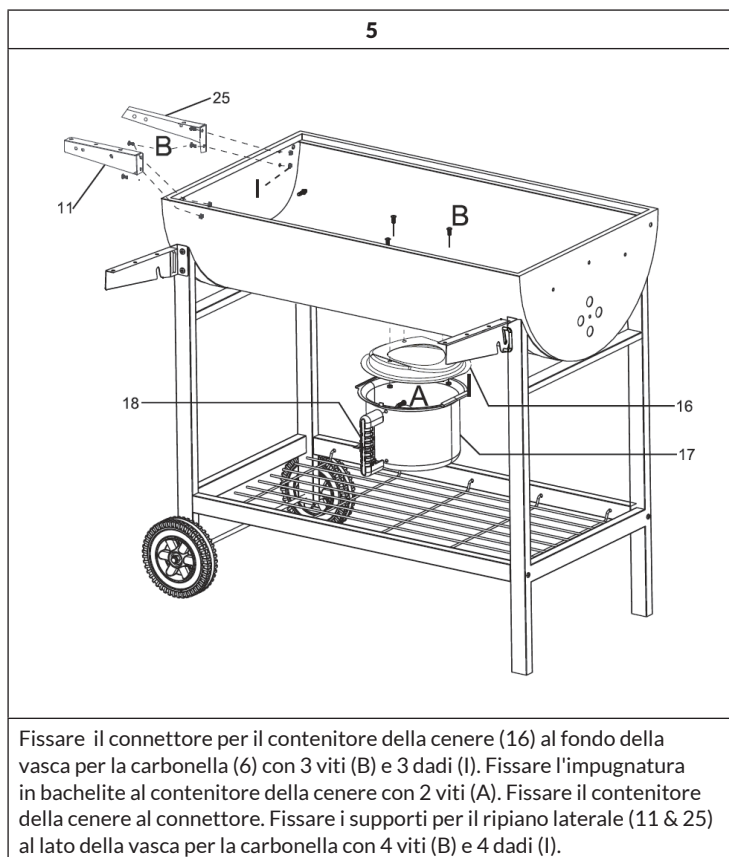

6

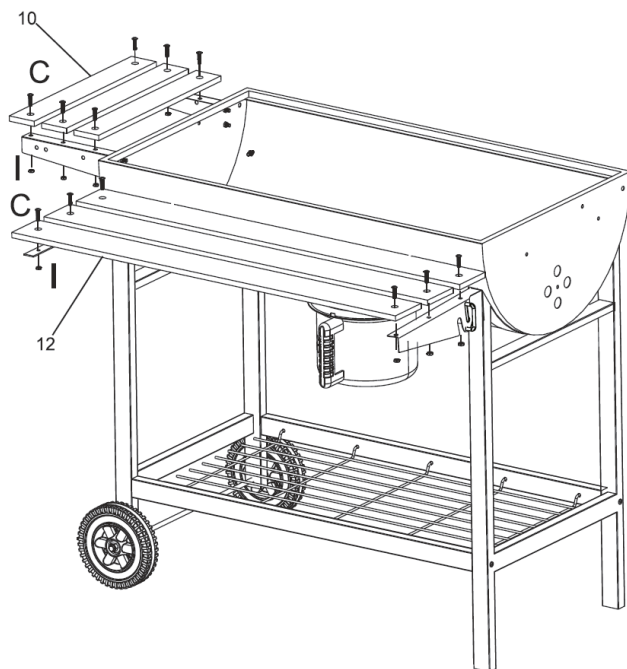

Fissare le parti in legno del ripiano anteriore (12) al relativo supporto (13) con 6 viti (C) e 6 dadi (I). Posizionare i pannelli per l'appoggio laterale (10) sui sostegni (11) e fissarli con 6 viti (C) e 6 dadi (I).

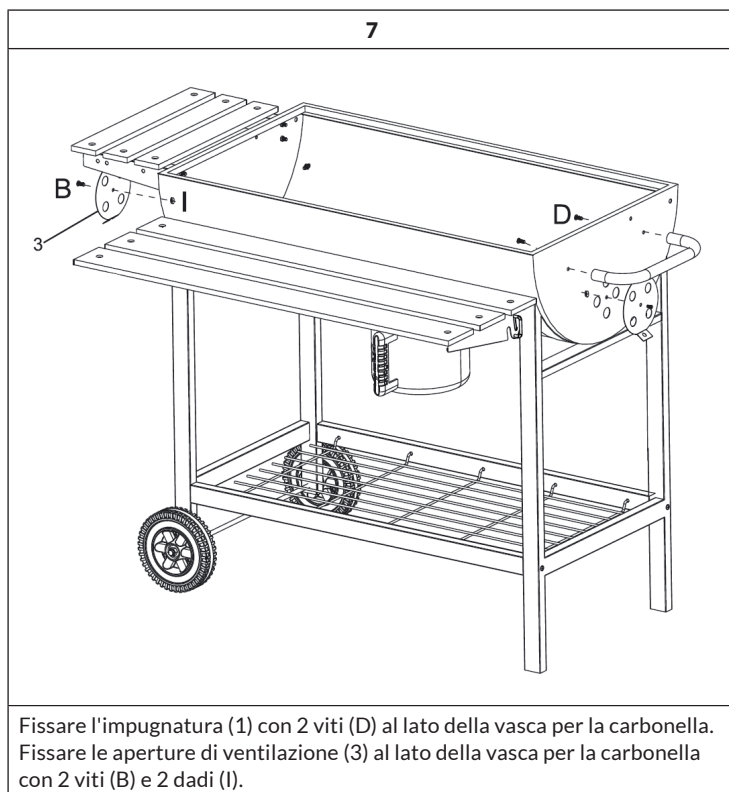

8

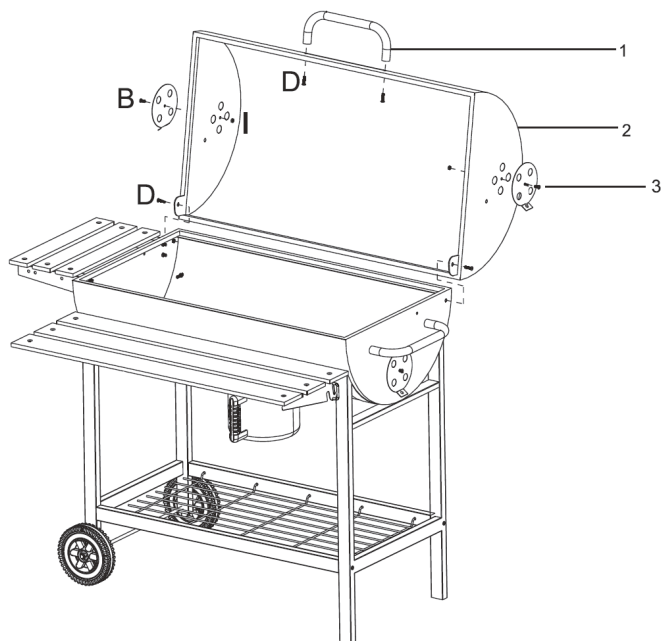

Posizionare il coperchio (2) sulla vasca per la carbonella (6). Allineare il foro filettato sul retro del coperchio con i fori della vasca per la carbonella e fissare il coperchio con 2 viti (D). Fissare le aperture di ventilazione (3) al lato del coperchio con 2 viti (B) e 2 dadi (I). Fissare l'impugnatura (1) con 2 viti (D) al lato anteriore del coperchio.

9

Quando tutte le parti sono completamente assemblate, stringere tutte le viti e i dadi. Poggiare la griglia per la carbonella (8) nella vasca. Posizionare la griglia (7) sulla vasca e fissare la griglia di mantenimento calore tra il coperchio e la vasca per la carbonella. Infine, fissare le impugnature alla griglia (23).

