

Ref. No.: 150.672

WH-248 LED WASH 24X 8W QUAD DMX



MANUAL

Thank you for purchasing one of our products. Before you use this product please read these instructions carefully to enjoy optimal performance and a longer service life.

UNPACKING INSPECTIONS

Unpacking instructions

- Please unpack the carton and check the goods carefully when you receive it , if you discover any packing damage, shortage or quality problems, please notify the shipper and reject the goods.
- Before using this product, please read the instructions carefully and store them in a safe place for future reference.

SAFETY INSTRUCTIONS

- Always connect this product to a grounded circuit to avoid the risk of electrocution.
- Never put tiny metal objects such as a screwdriver, iron wire, etc. into this product in case of a short circuit .
- Please make sure that the voltage of the outlet to which you are connecting this product is within the range stated on the decal or rear panel of the product.
- Avoid physical damage to the product during transportation. Never carry this product from the power cord or any moving part . Always use the hanging / mounting bracket or the handles.
- This product is for indoor use only. To avoid risk of fire or shock, do not expose this product to rain or moisture.
- Never pull or tug on the cord and change it for another one, stop using it when it is damaged or becomes hot .
- Stop using the product once there are sparks when connecting it to the power socket.
- Do not operate this product with wet hands and never place it near water or any other liquids.
- Make sure there are no flammable materials close to the unit while operating. Always install it in a location with adequate ventilation.
- When the original lightning source is damaged, do not replace it with a lightning source which has different specifications and ratings.
- Always disconnect this product from the power source before replacing the light source or the fuse.
- The maximum ambient temperature is 40°C(104°F).
- Never clean the unit with water, thinner or any other dissolving agent .
- Stop using the product in case of a serious operating problem and send it to our maintenance agent immediately. Never get this product repaired by non-professional workers.
- Avoid direct eye exposure to the light source while this product is on.
- Never clean the fixture by water, thinner or other dissolved agent .
- Stop using the product in case of a serious operating problem and send it to our maintenance agent immediately. Never repair by non-professional workers .
- Avoid direct eye exposure to the light source while the product is on.

SPECIFICATION

Tilt movement: 220° manually
No. of LEDs: 24x 8W Quad LEDs
No. of patterns: 10
DMX channels: 1-4-8
IP Rating: IP65
Power Supply: 220-240Vac / 50Hz
Consumption: 230W

MAINTENANCE

The unit should be cleaned periodically to ensure the optimal performance, smudginess can decrease the life of the light source and the output of light is affected by the dust which can make the machine overheat. It is advised to perform maintenance 2 times a month. Be sure to disconnect the unit from the power socket before cleaning.

Do not clean until the unit recovers a normal temperature, use the lens tissue or soft cotton cloth with alcohol and wipe gently.

The cleaning frequency depends on the environment in which this unit operates, damp, smoky or dirty surroundings can cause greater accumulation of dirt on the optics. Never rub or press strongly on the panel.

FUNCTIONS INTRODUCTIONS

Main Functions

- 1, 4 or 8 DMX channels.
- DMX, auto and master/slave mode .
- 24x 8W Quad LEDs
- 10 Built-in programs
- Electronic dimming 0 – 100%

SYSTEM MENU

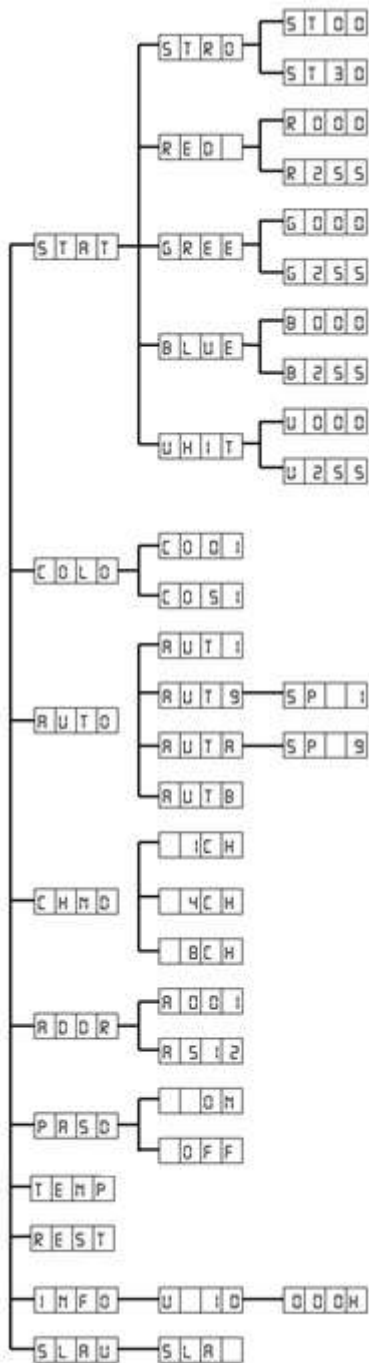

Stat - Set the static color mode and strobe mode

Press MENU, press the UP or DOWN button until “Stat” is displayed, press ENTER.

You have now 5 options. To select the desired option press ENTER. With the UP and DOWN button the desired value can be set. Press ENTER to confirm the desired value.

Colo - Built-in color mix

Press MENU, press the UP or DOWN button until “Colo” is displayed, press ENTER.

“Colx” will now be displayed, (“x” representing a number between 0 - 51). Press the UP or DOWN button to find the desired static mode. Press ENTER to confirm.

Auto mode - This menu will let you select the desired auto mode

Press MENU, press the UP or DOWN button until "Auto" is displayed, press ENTER. There are 11 auto modes, press the UP or DOWN button to select the desired mode, press ENTER to confirm.

Channel mode - Select the desired channel mode

Press MENU, press the UP or DOWN button until "Chnd" is displayed, press ENTER "X Ch" will now be displayed, ("X" represents the displayed channel mode). Press the UP or DOWN button to find the desired channel mode. Press ENTER to confirm.

DMX Address - Set the DMX address

Press MENU, press the UP or DOWN button until "Addr" is displayed, press ENTER. "Axxx" will now be displayed, ("xxx" represents the displayed address). Press the UP or DOWN button to find the desired address. Press ENTER to confirm

Passd - Password function switch

Press MENU, press the UP or DOWN button until "Passd" is displayed, press ENTER. Set the password for the password function. Password is MENU – UP – DOWN – ENTER
Temp: Temperature
rEST: Reset

Info - Will display the software version and working time of the unit.

Press MENU, press the UP or DOWN button until "Info" is displayed, press ENTER. The software version of the unit will be displayed. Press MENU to leave this function

Slave mode - In this mode the unit functions as a slave

Press MENU, press the UP or DOWN button until "Slav" is displayed, press ENTER. "Sla" will now be displayed, Slave mode is confirmed. The unit will now act as a slave in Auto, sound and chase mode.

OPERATING INSTRUCTIONS

DMX connection.

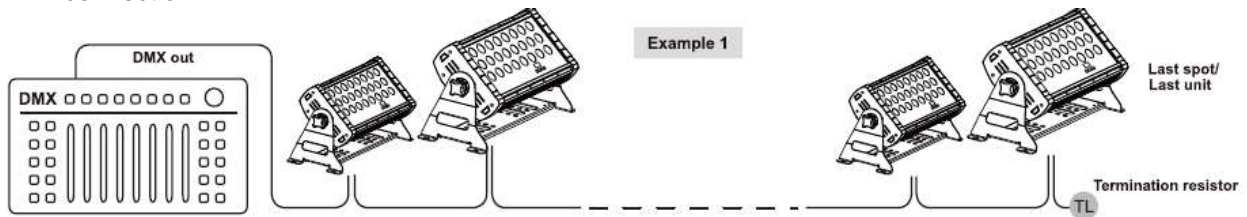

Master / Slave connection.

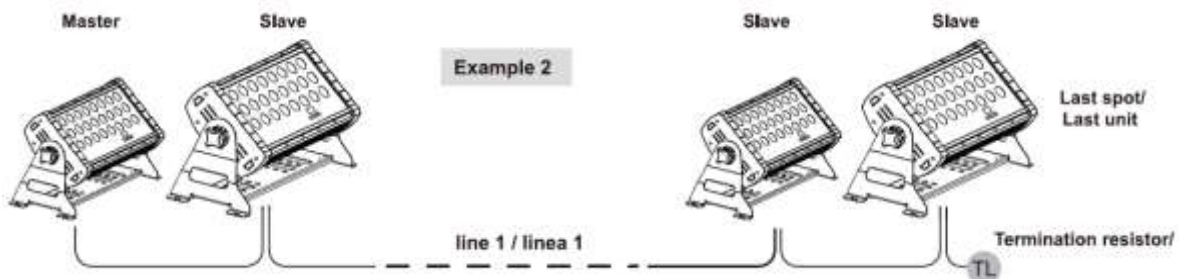

DMX CHANNELS

1 DMX Channel mode

DMX	Value	Description
1	000 – 000	Light off
	001 – 004	Color 1
	005 – 009	Color 2
	010 – 014	Color 3
	~	
	240 – 244	Color 49
	245 – 249	Color 50
	250 – 255	Color 51

4 DMX Channel mode

DMX	Value	Description
1	000 – 255	Red
2	000 – 255	Green
3	000 – 255	Blue
4	000 – 255	White

8 DMX Channel mode

DMX	Value	Description
1	000 – 255	Master dimmer
2	000 – 255	Red
3	000 – 255	Green
4	000 – 255	Blue
5	000 – 255	White
6	000 – 255	Strobe
7	000 – 000	Channel 1 – 6
	001 – 024	Auto 1
	025 – 049	Auto 2
	050 – 074	Auto 3
	075 – 099	Auto 4
	100 – 124	Auto 5
	125 – 149	Auto 6
	150 – 174	Auto 7
	175 – 199	Auto 8
	200 – 224	Auto 9
	225 – 249	Auto 10
250 – 255	Auto 11	
8	000-255	Auto Speed Ch 7 (slow-fast)



tronios
Sound & Light

CE Declaration of Conformity

Importer: TRONIOS BV
Bedrijvenpark Twente 415
7602 KM - ALMELO

Tel : 0031546589299
Fax : 0031546589298
The Netherlands

Product number: **150.672**
Product Description: **WH-248 LED Wash 24x 8W Quad DMX**

Regulatory Requirement: EN 60598-1/-2-17
EN 55015
EN 61547
EN 61000-3-2/-3-3

The product meets the requirements stated in Directives 2006/95 and 2004/108/EC and conforms to the above mentioned Declarations.

13-12-2012

Signature:

P. Feldman

Specifications and design are subject to change without prior notice..

www.tronios.com

Copyright © 2013 by TRONIOS the Netherlands