

10026904 10026905

## Miri

Kinderschaukel

Kids Swing

Columpio infantil

Balançoire pour enfants

Altalena per bambini



**Sehr geehrter Kunde,**

wir gratulieren Ihnen zum Erwerb Ihres Gerätes. Lesen Sie die folgenden Hinweise sorgfältig durch und befolgen Sie diese, um möglichen Schäden vorzubeugen. Für Schäden, die durch Missachtung der Hinweise und unsachgemäßen Gebrauch entstehen, übernehmen wir keine Haftung. Scannen Sie den folgenden QR-Code, um Zugriff auf die aktuellste Bedienungsanleitung und weitere Informationen rund um das Produkt zu erhalten.



---

## INHALTSVERZEICHNIS

---

Sicherheitshinweise 4  
 Lieferumfang 6  
 Montage 6  
 Hersteller & Importeur (UK) 8

**English 9**  
**Español 15**  
**Français 21**  
**Italiano 27**

---

## TECHNISCHE DATEN

---

Artikelnummer	10026904, 10026905
Maximal zulässiges Körpergewicht	Bis zu 45 kg

## SICHERHEITSHINWEISE

### Hinweise zur Alters- und Gewichtsbeschränkung

	<p>Die Schaukel eignet sich für Kinder im Alter von 3-8 Jahren. Die Schaukel ist nicht für Kinder unter 3 Jahren geeignet, da sie sich an Kleinteilen oder den langen Seilen verletzen könnten. Die Schaukel eignet sich nicht für Erwachsene oder Kinder mit einem Gewicht von mehr als 45 kg.</p>
---	---

### Allgemeine Hinweise

- Es darf immer nur ein Kind gleichzeitig auf der Schaukel sitzen.
- Die Schaukel ist für den Außenbereich konzipiert.
- Überprüfen Sie vor jeder Benutzung alle Muttern, Schrauben und Anschlusssteile auf festen Sitz und ziehen Sie sie nach, wenn nötig.
- Überprüfen Sie vor jeder Benutzung alle Abdeckungen für Schrauben und scharfe Kanten und ersetzen Sie sie, falls nötig.
- Ölen Sie regelmäßig alle beweglichen Metallteile.
- Überprüfen Sie regelmäßig den Schaukelsitz, die Seile und alle anderen Teile auf Verschleiß. Falls nötig, ersetzen Sie die Teile nach Anweisung des Herstellers.
- Überprüfen Sie die Schaukel in regelmäßigen Abständen vorsorglich auf Anzeichen für Verschleiß und Schäden.

### Hinweise zu Standort

- Stellen Sie die Schaukel auf einen flachen, ebenen Untergrund und halten Sie um die Schaukel mindestens 2 Meter Abstand zu Zäunen, Garagen, Häusern, Mauern, herunterhängenden Ästen oder elektrischen Kabeln.
- Aus Sicherheitsgründen muss die Schaukel im Boden verankert werden. Verankern Sie die Schaukel bündig am oder im Boden, damit niemand über die Verankerung stolpert.
- Achten Sie darauf, dass Ihr Kind nicht der Sonne zugewandt schaukelt, um Augenschäden durch direktes Sonnenlicht zu vermeiden.
- Um sich den Aufbau zu erleichtern, ziehen Sie alle Zubehörteile zunächst nur handfest an. Ziehen Sie die Teile erst fest, wenn Sie den Aufbau beendet haben.
- Stellen Sie die Schaukel nicht auf einen betonierten, asphaltierten oder harten Untergrund.













## Hinweise zur Benutzung

- Achten Sie darauf, dass Kinder nicht im Stehen schaukeln.
- Achten Sie darauf, dass Kinder nicht von der Schaukel steigen, solange sie sich noch bewegt.
- Verdrehen Sie die Schwingseile nicht und wickeln Sie sie nicht um die obere Stange.
- Achten Sie darauf, dass Kinder beim Schaukeln keine weite, offene Kleidung oder Kapuzenshirts anhaben, damit sie sich mit der Kleidung nicht in der Schaukel verfangen.
- Achten Sie darauf, dass Kinder nicht auf der Schaukel herumklettern.
- Achten Sie darauf, dass andere Kinder nicht in der Nähe der Schaukel spielen, solange sie benutzt wird.

## Hinweise zu Aufbau und Wartung

- Um Verletzungen zu vermeiden, halten Sie sich genau an die hier beschriebenen Hinweise zum Aufbau und zur Wartung.
- Verpackungsmaterialien sind kein Spielzeug. Entsorgen Sie alle Verpackungsmaterialien umgehend und achten Sie darauf, dass Sie nicht in die Hände von Kindern gelangen.
- Die Schaukel darf nur von Erwachsenen zusammengebaut werden.
- Unter Aufsicht eines Erwachsenen darf die Wartung auch von Kindern durchgeführt werden.
- Das Gerät ist nur für private Haushalte ausgelegt.
- Sobald die Schaukel komplett zusammengebaut ist, überprüfen Sie sie vor der Benutzung noch einmal sorgfältig. Falls Sie problematische Stellen oder Schäden entdecken, achten Sie darauf, dass niemand die Schaukel benutzt, bis sie wieder einsatzfähig ist.

# LIEFERUMFANG

<b>A x 1</b> 	<b>B x 2</b> 	<b>C x 2</b> 	<b>D x 4</b> 	<b>E x 2</b> 
<b>F x 1</b> 	<b>G x 4</b> 	<b>H x 2 (M8)</b> 	<b>I x 4 ( M8X50 mm)</b> 	<b>J x 4 ( M8X63 mm)</b> 
<b>K x 1</b> 	<b>L x 1</b> 			

# MONTAGE

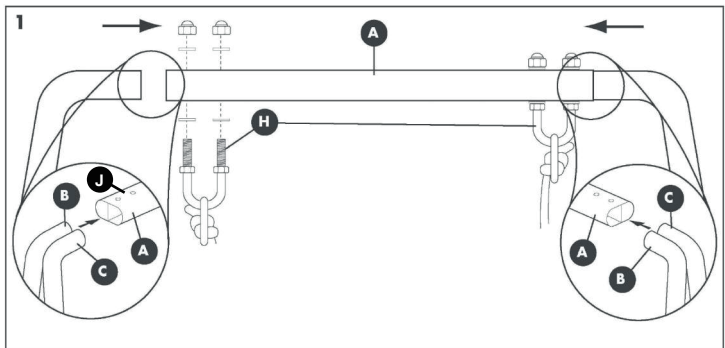

Befestigen Sie vor dem Anschrauben die Seilklemme (F) am Rundbügel (H).

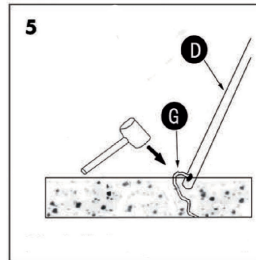
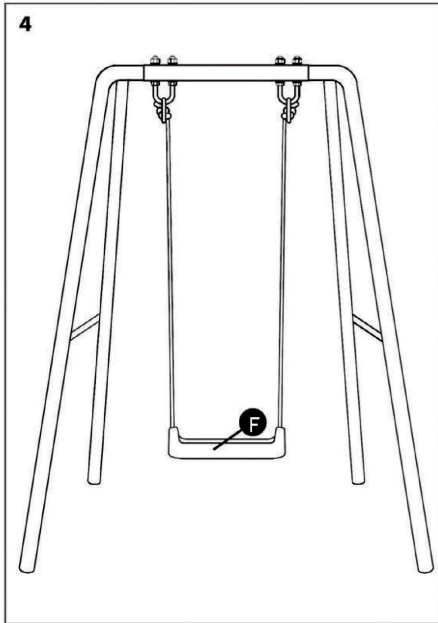
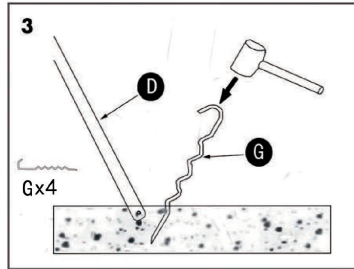
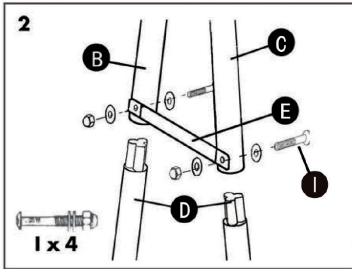

Verankern Sie die Schaukel  
im Boden.

---

## HERSTELLER & IMPORTEUR (UK)

---

**Hersteller:**

Chal-Tec GmbH, Wallstraße 16, 10179 Berlin, Deutschland.

**Importeur für Großbritannien:**

Berlin Brands Group UK Ltd  
PO Box 1145  
Oxford, OX1 9UW  
United Kingdom



**Dear Customer,**

Congratulations on purchasing this device. Please read the following instructions carefully and follow them to prevent possible damages. We assume no liability for damage caused by disregard of the instructions and improper use. Scan the QR code to get access to the latest user manual and more product information.



---

**CONTENT**

---

Safety Instructions 10  
Scope of Delivery 12  
Assembly 12  
Manufacturer & Importer (UK) 14

---

**TECHNICAL DATA**

---

Item number	10026904, 10026905
Maximum permissible body weight	Up to 45 kg

## SAFETY INSTRUCTIONS

### Hints on age and weight

	<p>Suitable for children aged 3-8 years. Not suitable for children under the age of 36 months because of small part(s) and because of long cord(s) – choking and entanglement/strangulation hazards. This item is not for adults or children weighing more than 45 kg.</p>
---	--

### General Hints

- Only one child per seat at any one time.
- For outdoor use.
- Check all nuts, bolts and fittings for tightness and tighten if required.
- Check all coverings for bolts and sharp edges and replace when required
- Oil all metallic moving parts.
- Check swing seats, ropes and other means of attachments for evidence of deterioration. Replace when required in accordance with the manufacturer's instructions.
- As an extra precaution, check this toy regularly for signs of wear and damage.

### Hints on Placement

- Place the product on a level surface at least 2 metres from any obstructions such as a fence, garage, house, wall, overhanging branches, laundry line or electrical wires.
- For safety reasons, this swing must be anchored into the ground.
- Anchors shall be placed level with or under the ground in order to reduce tripping hazards.
- Ensure the child is not facing the sun when on the swing.
- Leave all fittings finger-tight until assembly is complete, for ease of construction. Then tighten firmly.
- Do not install the product on concrete, asphalt or hard surfaces.













## Hints on Use

- Do not allow children to stand on the swing or glider seats.
- Do not allow children to get off the swings or glider while they are still moving.
- Do not twist swing ropes or wrap them over the top bar.
- Do not allow loose, hooded or baggy clothes to be worn since children can get trapped and may be unable to free themselves.
- Do not allow children to climb on this equipment.
- Do not allow children to wander into the play area when the equipment is in use.
- Gliders and swings must not exceed an angle of 60 degrees from the ground.

## Hints on mounting and maintenance

- Failure to assemble and maintain this item as per these instructions may cause injury to the user.
- Packaging materials are not toys. Please remove all packaging and packing tags / wires before giving this toy to your child.
- Adult assembly required.
- For use under adult supervision.
- Maintenance to be carried out under the direct supervision of a responsible adult.
- For family domestic use only.
- Once assembly is complete, carefully check the equipment before use. If you find any problems, do not allow children to use the equipment until it is fit for use.

## SCOPE OF DELIVERY

<b>A x 1</b> 	<b>B x 2</b> 	<b>C x 2</b> 	<b>D x 4</b> 	<b>E x 2</b> 
<b>F x 1</b> 	<b>G x 4</b> 	<b>H x 2 (M8)</b> 	<b>I x 4 (M8X50 mm)</b> 	<b>J x 4 (M8X63 mm)</b> 
<b>K x 1</b> 	<b>L x 1</b> 			

## ASSEMBLY

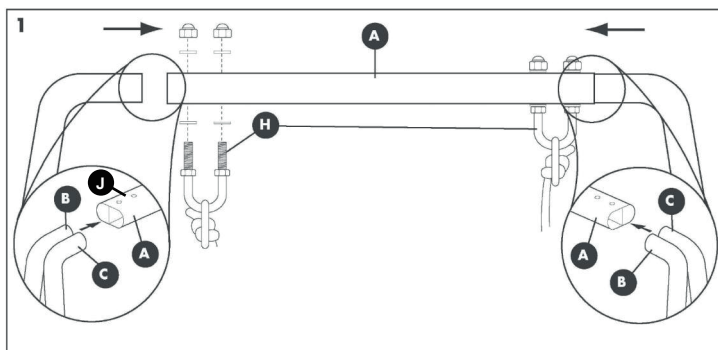

Before screwing on, fasten the rope clamp (F) to the round bracket (H).

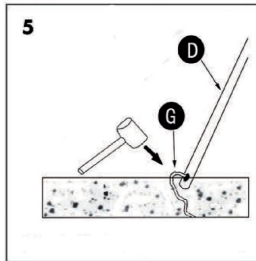
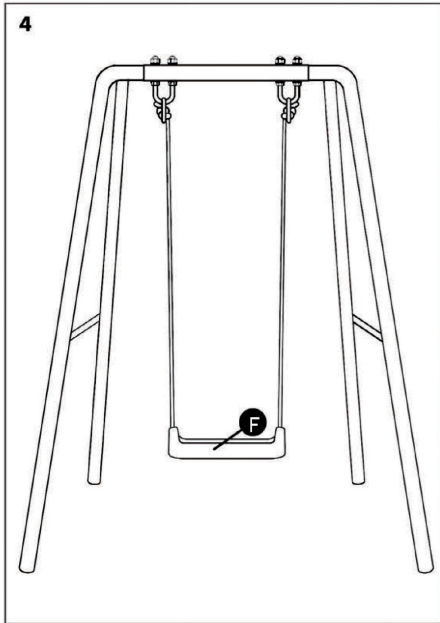
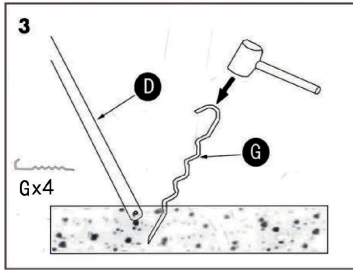
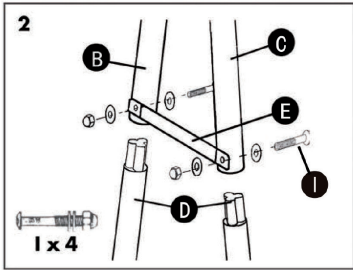

Anchor the swing in the ground.

---

## MANUFACTURER & IMPORTER (UK)

---

**Manufacturer:**

Chal-Tec GmbH, Wallstrasse 16, 10179 Berlin, Germany.

**Importer for Great Britain:**

Berlin Brands Group UK Ltd

PO Box 1145

Oxford, OX1 9UW

United Kingdom

**Estimado cliente,**

Le felicitamos por la adquisición de este producto. Lea atentamente las siguientes instrucciones y sígalas para evitar posibles daños. No asumimos ninguna responsabilidad por los daños causados por el incumplimiento de las instrucciones y el uso inadecuado. Escanee el siguiente código QR para obtener acceso a la última guía del usuario y más información sobre el producto.



---

## ÍNDICE

---

Indicaciones de seguridad	16
Envío	18
Montaje	18
Fabricante e importador (Reino Unido)	20

---

## DATOS TÉCNICOS

---

Número de artículo	10026904, 10026905
Capacidad de carga máxima	Hasta 45 kg

## INDICACIONES DE SEGURIDAD

### Indicaciones sobre las restricciones de edad y peso

	<p>El columpio está diseñado para niños de entre 3 y 8 años de edad. El columpio no es adecuado para niños menores de 3 años, ya que podrían lesionarse con piezas pequeñas o cuerdas largas. El columpio no es adecuado para adultos o niños que pesen más de 45 kg.</p>
---	---

### Indicaciones generales

- Solamente un niño puede sentarse en el columpio a la vez.
- El columpio está diseñado para uso en el exterior.
- Antes de cada uso, compruebe que todas las tuercas, tornillos y otras piezas estén bien atornilladas; ajústelas más si es necesario.
- Antes de cada uso, revise todas las cubiertas en busca de tornillos y bordes afilados y reemplácelos si es necesario.
- Lubrique regularmente todas las piezas metálicas móviles.
- Revise regularmente el asiento del columpio, las cuerdas y todas las demás partes para ver si están desgastadas. De ser necesario, reemplace las piezas siguiendo las instrucciones del fabricante.
- Revise regularmente el columpio como medida de precaución para detectar signos de desgaste y daños.

### Indicaciones sobre el lugar de instalación

- Instale el columpio en una superficie plana y nivelada y conserve una distancia de al menos 2 metros entre el columpio y vallas, garajes, casas, paredes, ramas o cables eléctricos.
- Por motivos de seguridad, ancle el columpio al suelo. Ancle el columpio a ras del suelo o en el suelo para que nadie tropiece con el anclaje.
- Asegúrese de que su hijo no balancee en dirección del sol para evitar que se dañe los ojos por la luz solar directa.
- Para facilitar el montaje, apriete todas las piezas solo a mano al principio. Atornille todas las piezas fuertemente una vez finalizado el montaje.
- No instale el columpio sobre una superficie dura, de hormigón o asfalto.















**Indicaciones sobre el uso**

- No permita que los niños se columpien de pie.
- Asegúrese de que los niños no se levanten del columpio mientras este esté en movimiento.
- No tuerza las cuerdas ni las envuelva alrededor de la barra superior.
- Asegúrese de que los niños no usen ropa ancha o sudaderas con capucha cuando se columpien, para evitar que se enreden en el columpio con su ropa.
- No permita que los niños trepen por el columpio.
- Asegúrese de que no haya niños jugando cerca del columpio mientras esté este en movimiento.

**Indicaciones sobre el montaje y mantenimiento**

- Para evitar lesiones, siga exactamente las instrucciones de montaje y mantenimiento aquí descritas.
- El material de embalaje no es un juguete. Deseche todo el material de embalaje y asegúrese de que no llegue a las manos de los niños.
- Solamente un adulto debe montar el columpio.
- Los niños podrán llevar a cabo los trabajos de mantenimiento solamente si están bajo la supervisión de un adulto.
- El columpio solo es apto para uso doméstico.
- Una vez que el columpio esté completamente ensamblado, compruébelo cuidadosamente antes de usarlo. Si detecta puntos problemáticos o daños, asegúrese de que nadie use el columpio hasta que estos no se reparen.

# ENVÍO

<b>A x 1</b> 	<b>B x 2</b> 	<b>C x 2</b> 	<b>D x 4</b> 	<b>E x 2</b> 
<b>F x 1</b> 	<b>G x 4</b> 	<b>H x 2 (M8)</b> 	<b>I x 4 ( M8X50 mm)</b> 	<b>J x 4 ( M8X63 mm)</b> 
<b>K x 1</b> 	<b>L x 1</b> 			

# MONTAJE

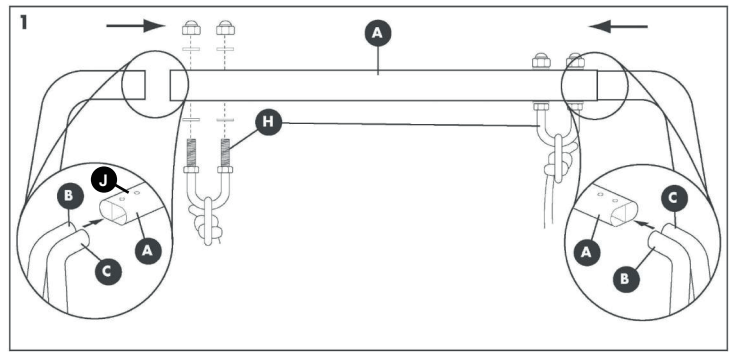

Monte la abrazadera de la cadena (F) en el soporte redondo (H).

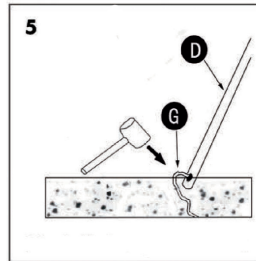
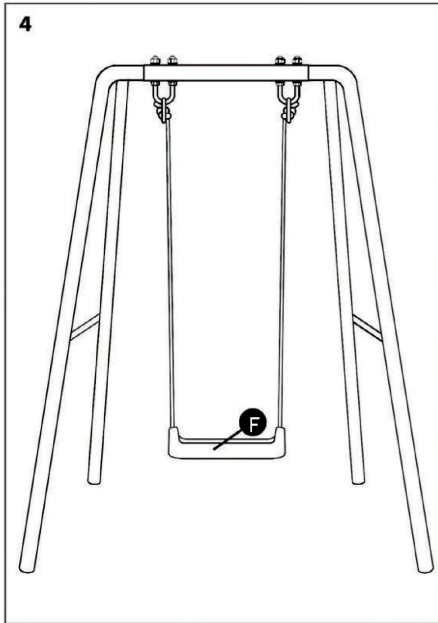
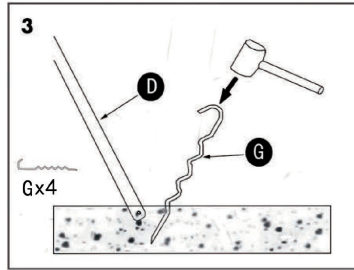
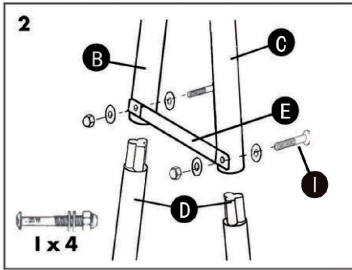

Ancle el columpio al suelo.

---

## FABRICANTE E IMPORTADOR (REINO UNIDO)

---

**Fabricante:**

Chal-Tec GmbH, Wallstraße 16, 10179 Berlín, Alemania.

**Importador para Gran Bretaña:**

Berlin Brands Group UK Ltd

PO Box 1145

Oxford, OX1 9UW

United Kingdom

**Chère cliente, cher client,**

Toutes nos félicitations pour l'acquisition de ce nouvel appareil. Veuillez lire attentivement et respecter les instructions de ce mode d'emploi afin d'éviter d'éventuels dommages. Nous ne saurions être tenus pour responsables des dommages dus au non-respect des consignes et à la mauvaise utilisation de l'appareil. Scannez le QR-Code pour obtenir la dernière version du mode d'emploi et des informations supplémentaires concernant le produit.



---

**SOMMAIRE**

---

Consignes de sécurité 22  
Contenu de l'emballage 24  
Montage 24  
Fabricant et importateur (UK) 26

---

**FICHE TECHNIQUE**

---

Numéro d'article	10026904, 10026905
Poids total utilisateur maximal autorisé	Jusqu'à 45 kg

## CONSIGNES DE SÉCURITÉ

### Remarques sur les restrictions d'âge et de poids

	<p>La balançoire est adaptée pour des enfants âgés entre 3-8 ans. La balançoire ne convient pas à des enfants de moins de 3 ans, car ils pourraient se blesser avec les petits éléments ou les longues cordes. La balançoire ne convient pas aux adultes ou aux enfants dont le poids dépasse 45 kg.</p>
---	--

### Consignes générales

- Il doit toujours se trouver un seul enfant à la fois sur la balançoire.
- La balançoire est conçue pour une utilisation en extérieur.
- Avant utilisation, vérifiez que tous les écrous, les vis et les assemblages sont bien fixés et resserrez-les si besoin.
- Avant utilisation, vérifiez tous les caches des vis et autres bords coupants et remplacez-les si besoin.
- Lubrifiez régulièrement toutes les parties métalliques mobiles.
- Contrôlez régulièrement le niveau d'usure du siège de la balançoire, de la corde et de toutes les autres pièces. Si nécessaire, remplacez les pièces selon les instructions du fabricant.
- Vérifiez à intervalles réguliers les signes éventuels d'usure ou les dommages de la balançoire.

### Consignes sur l'emplacement

- Placez la balançoire sur une surface plane et de niveau à au moins 2 mètres des clôtures, garages, maisons, murs, branches suspendues ou câbles électriques.
- Pour des raisons de sécurité, la balançoire doit être ancrée au sol. Les fixations de la balançoire doivent affleurer ou être dans le sol afin que personne ne trébuche dessus.
- Assurez-vous que votre enfant ne se balance pas face au soleil pour éviter les dommages oculaires causés par la lumière directe du soleil.
- Pour faciliter l'assemblage, serrez d'abord tous les accessoires à la main. Ne serrez pas les pièces avant d'avoir terminé l'assemblage.
- Ne placez pas la balançoire sur du béton, de l'asphalte ou une surface dure.













## Consignes d'utilisation

- Assurez-vous que les enfants ne se balancent pas en position debout.
- Assurez-vous que les enfants ne descendent pas de la balançoire en mouvement.
- Ne tordez pas les câbles pivotants et ne les enroulez pas autour de la barre supérieure.
- Assurez-vous que les enfants ne portent pas de vêtements amples, ouverts ou à capuche lorsqu'ils se balancent, afin que les vêtements ne se prennent pas dans la balançoire.
- Assurez-vous que les enfants ne grimpent pas sur la balançoire.
- Assurez-vous que les autres enfants ne jouent pas près de la balançoire pendant son utilisation.

## Consignes de montage et d'entretien

- Afin d'éviter les blessures, suivez précisément les instructions d'installation et d'entretien décrites ici.
- Les matériaux d'emballage ne sont pas des jouets. Jetez immédiatement tous les matériaux et assurez-vous qu'ils ne tombent pas entre les mains des enfants.
- La balançoire ne peut être assemblée que par des adultes.
- L'entretien peut éventuellement être effectué par des enfants sous la surveillance d'un adulte.
- L'appareil est uniquement conçu pour un usage privé.
- Une fois la balançoire entièrement assemblée, vérifiez-la à nouveau soigneusement avant utilisation. Si vous découvrez des problèmes ou des dommages, assurez-vous que personne n'utilise la balançoire jusqu'à ce qu'elle soit à nouveau en état.

## CONTENU DE L'EMBALLAGE

<b>A x 1</b> 	<b>B x 2</b> 	<b>C x 2</b> 	<b>D x 4</b> 	<b>E x 2</b> 
<b>F x 1</b> 	<b>G x 4</b> 	<b>H x 2 (M8)</b> 	<b>I x 4 (M8X50 mm)</b> 	<b>J x 4 (M8X63 mm)</b> 
<b>K x 1</b> 	<b>L x 1</b> 			

## MONTAGE

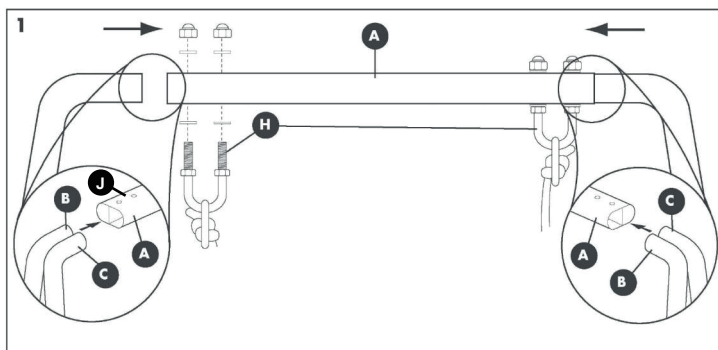

Avant de visser, fixez le serre-câble (F) au support rond (H).



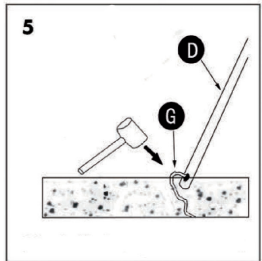
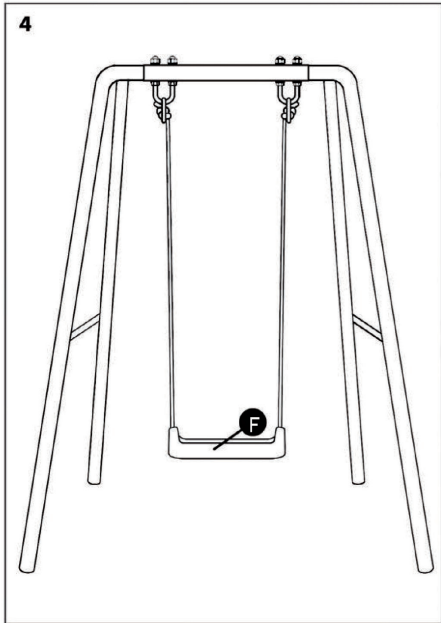
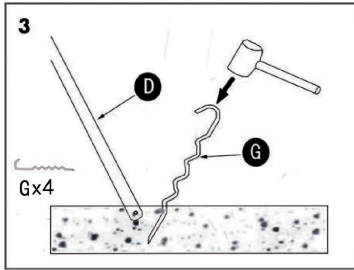
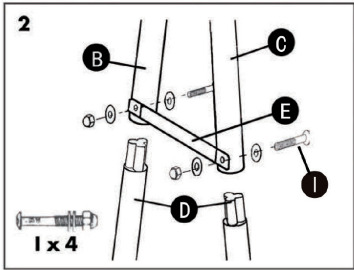

Ancrez la balançoire au sol.

---

## FABRICANT ET IMPORTATEUR (UK)

---

**Fabricant :**

Chal-Tec GmbH, Wallstraße 16, 10179 Berlin, Allemagne.

**Importateur pour la Grande Bretagne :**

Berlin Brands Group UK Ltd

PO Box 1145

Oxford, OX1 9UW

United Kingdom

**Gentile cliente,**

La ringraziamo per aver acquistato il dispositivo. La preghiamo di leggere attentamente le seguenti istruzioni per l'uso e di seguirle per evitare possibili danni. Non ci assumiamo alcuna responsabilità per danni scaturiti da una mancata osservazione delle avvertenze di sicurezza e da un uso improprio del dispositivo. Scansionare il codice QR seguente, per accedere al manuale d'uso più attuale e per ricevere informazioni sul prodotto.



---

**INDICE**

---

Avvertenze di sicurezza 28  
Volume di consegna 30  
Montaggio 30  
Produttore e importatore (UK) 32

---

**DATI TECNICI**

---

Numero articolo	10026904,10026905
Peso corporeo massimo consentito	Fino a 45 kg

## AVVERTENZE DI SICUREZZA

### Avvertenze sulle limitazioni relative a età e peso

	<p>L'altalena è adatta a bambini da 3 a 8 anni. L'altalena non è adatta a bambini sotto i 3 anni, dato che potrebbero subire lesioni a causa di piccoli componenti o delle lunghe funi. L'altalena non è adatta a persone adulte e bambini che superano i 45 kg di peso.</p>
---	--

### Avvertenze generiche

- Sull'altalena può essere seduto solo un bambino alla volta.
- L'altalena è progettata per spazi all'aperto.
- Prima di ogni utilizzo, controllare che tutti i bulloni, le viti e i connettori siano fissati saldamente e stringerli, se necessario.
- Prima di ogni utilizzo, controllare tutte le coperture per viti sporgenti o bordi taglienti e sostituirli, se necessario.
- Oliare regolarmente tutti i componenti mobili in metallo.
- Controllare regolarmente se la seduta dell'altalena, le funi e tutti gli altri componenti presentano usura. Se necessario, sostituire i componenti in base alle indicazioni del produttore.
- Controllare l'altalena a intervalli regolari, in modo da prevenire usura e danni.

### Avvertenze sul luogo di posizionamento

- Posizionare l'altalena su un fondo piano e tenerla ad almeno 2 metri di distanza da recinti, garage, case, mura, rami pendenti o cavi elettrici.
- Per motivi di sicurezza, l'altalena deve essere ancorata al suolo. Ancorarla a livello con il suolo, in modo da non inciampare nell'ancoraggio.
- Assicurarci che i bambini non si dondolino diretti verso il sole, in modo da evitare danni agli occhi dovuti alla luce del sole diretta.
- Per facilitare il montaggio, stringere tutti i componenti solo a mano in un primo momento. Stringere saldamente solo ad assemblaggio concluso.
- Non posizionare l'altalena su un fondo in calcestruzzo, asfalto o altri materiali duri.













## **Avvertenze sull'utilizzo**

- Assicurarsi che i bambini non si dondolino stando in piedi.
- Assicurarsi che i bambini non scendano dall'altalena mentre è ancora in movimento.
- Non arrotolare le funi dell'altalena e non avvolgerle intorno all'asta superiore.
- Assicurarsi che i bambini non indossino abiti ampi o felpe col cappuccio quando si trovano sull'altalena, in modo che non si impiglino.
- Assicurarsi che i bambini non si arrampichino sull'altalena.
- Assicurarsi che non ci siano bambini che giocano vicino all'altalena mentre viene utilizzata.

## **Avvertenze su montaggio e manutenzione**

- Per evitare lesioni, rispettare con attenzione tutte le avvertenze su montaggio e manutenzione.
- I materiali di imballaggio non sono giocattoli. Smaltire tutti materiali di imballaggio immediatamente e assicurarsi che non finiscano nelle mani di bambini.
- L'altalena deve essere montata da persone adulte.
- La manutenzione può essere realizzata da bambini solo con l'attenta supervisione di un adulto.
- Il dispositivo è adatto solo a contesti privati.
- Non appena l'altalena è completamente montata, controllarla con cura un'altra volta prima dell'utilizzo. Se si scoprono parti problematiche o danni, assicurarsi che nessuno la utilizzi fino a quando è di nuovo pronta all'uso.

## VOLUME DI CONSEGNA

<b>A x 1</b> 	<b>B x 2</b> 	<b>C x 2</b> 	<b>D x 4</b> 	<b>E x 2</b> 
<b>F x 1</b> 	<b>G x 4</b> 	<b>H x 2 (M8)</b> 	<b>I x 4 (M8X50 mm)</b> 	<b>J x 4 (M8X63 mm)</b> 
<b>K x 1</b> 	<b>L x 1</b> 			

## MONTAGGIO

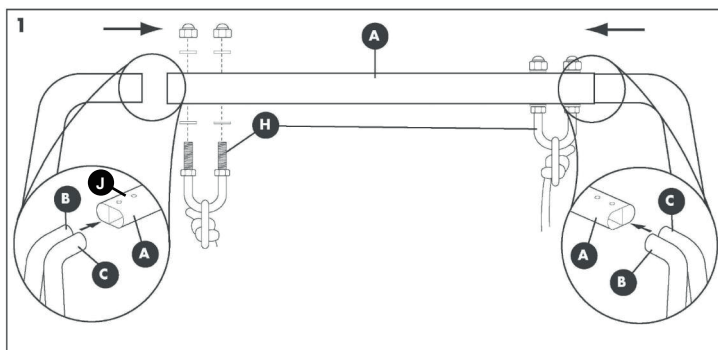

Prima di avvitare, fissare il gancio delle funi (F) all'archetto a U (H).

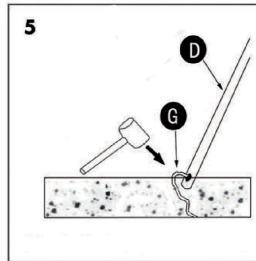
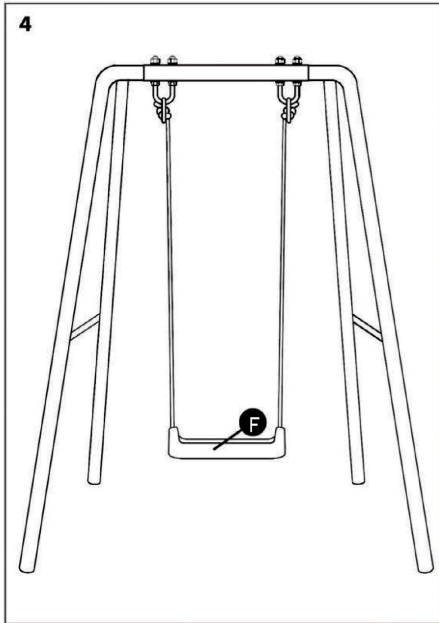
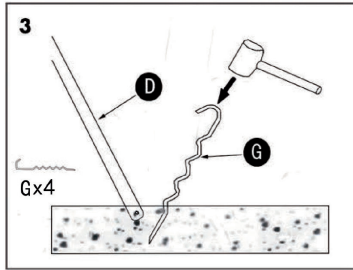
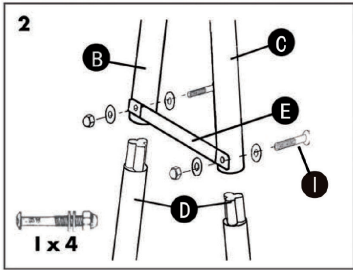

Ancorare l'altalena al suolo.

---

## PRODUTTORE E IMPORTATORE (UK)

---

**Produttore:**

Chal-Tec GmbH, Wallstraße 16, 10179 Berlino, Germania.

**Importatore per la Gran Bretagna:**

Berlin Brands Group UK Ltd  
PO Box 1145  
Oxford, OX1 9UW  
United Kingdom









