



CAPITAL SPORTS

**Tremendour
Tremendour Plus**

Power Rack

10027846 10027847 10028832 10028833
10029511 10029512 10029513 10029514

Sehr geehrter Kunde,

wir gratulieren Ihnen zum Erwerb Ihres Gerätes. Lesen Sie die folgenden Hinweise sorgfältig durch und befolgen Sie diese, um möglichen Schäden vorzubeugen. Für Schäden, die durch Missachtung der Hinweise und unsachgemäßen Gebrauch entstehen, übernehmen wir keine Haftung. Scannen Sie den QR-Code, um Zugriff auf die aktuellste Bedienungsanleitung und weitere Informationen rund um das Produkt zu erhalten.



WICHTIGE SICHERHEITSHINWEISE

1. Lesen Sie sich diese Bedienungsanleitung vor dem Aufbauen und Benutzen des Gerätes aufmerksam durch. Ein sicherer und effektiver Gebrauch des Gerätes kann nur erzielt werden, wenn das Gerät ordnungsgemäß aufgebaut, gepflegt und benutzt wird. Stellen Sie sicher, dass sämtliche Personen, die dieses Gerät nutzen, über die Warnungen und Sicherheitshinweise informiert sind.
2. Falls Sie Medikamente mit Auswirkungen auf Blutdruck, Herzschlag oder Cholesterinspiegel einnehmen, ist die Konsultation eines Arztes vor dem Training notwendig.
3. Achten Sie auf die Signale Ihres Körpers. Falsches oder übermäßiges Training kann gesundheitsschädlich sein. Beenden Sie umgehend das Training wenn Sie folgende Symptome feststellen: Schmerzen / Engegefühl in der Brust, unregelmäßiger Herzschlag, extreme Kurzatmigkeit, Anzeichen leichter Benommenheit, Schwindel oder Übelkeit. Falls Sie irgendwelche dieser Symptome an sich feststellen, sollten Sie einen Arzt aufsuchen, bevor Sie das Training fortsetzen.
4. Dieses Gerät ist nicht dafür bestimmt, durch Personen (einschließlich Kinder) mit eingeschränkten physischen, sensorischen oder geistigen Fähigkeiten oder mangels Erfahrung und/oder mangels Wissen benutzt zu werden, es sei denn, sie werden durch eine für ihre Sicherheit zuständige Person beaufsichtigt oder erhielten von ihr Anweisungen, wie das Gerät zu benutzen ist. Kinder sollten beaufsichtigt werden, um sicherzustellen, dass sie nicht mit dem Gerät spielen.
5. Stellen Sie vor jedem Training sicher, dass sämtliche Schrauben und Befestigungen ordnungsgemäß festgezogen sind.
6. Die Sicherheit des Gerätes kann nur gewährleistet werden, wenn das Gerät regelmäßig gepflegt und auf etwaige Schäden oder Abnutzungserscheinungen untersucht wird.

English 13
Español 23
Français 33
Italiano 43

7. Nutzen Sie das Gerät ausschließlich wie vorgesehen. Sollten Sie beim Aufbau oder bei der Kontrolle defekte Komponenten entdecken oder sollten Sie während des Trainings ungewöhnliche Geräusche am Gerät feststellen, beenden Sie umgehend das Training. Nutzen Sie das Gerät erst wieder nachdem das Problem identifiziert und gelöst wurde.
8. Tragen Sie angemessene Kleidung bei Benutzung des Gerätes. Vermeiden Sie weite Kleidung, die sich am Gerät verfangen könnte und die Ihre Bewegungsfreiheit einschränken könnten.
9. Das Gerät wurde gemäß EN 957 getestet und zertifiziert und ist für den häuslichen Gebrauch freigegeben. Das maximale Benutzergewicht sollte 120 kg nicht übersteigen.
10. Das Gerät ist nicht für therapeutischen Einsatz geeignet.

Kleine Objekte/Verpackungsteile

(Plastikbeutel, Karton, etc.)

Bewahren Sie die kleine Objekte (z.B. Schrauben und anderes Montagematerial) und Verpackungsteile außerhalb der Reichweite von Kindern auf, damit sie nicht von diesen verschluckt werden können. Lassen Sie kleine Kinder nicht mit Folie spielen. Es besteht Erstickungsgefahr!

Bestimmungsgemäßer Gebrauch

Dieses Gerät dient zum körperlichen Muskeltraining durch Durchführen von Klimmzügen und ähnlicher Übungen. Es ist ausschließlich für diesen Zweck bestimmt und darf nur zu diesem Zweck verwendet werden. Es darf nur in der Art und Weise benutzt werden, wie es in dieser Gebrauchsanleitung beschrieben ist.











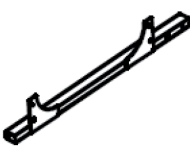
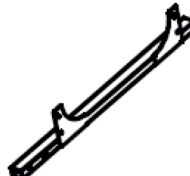
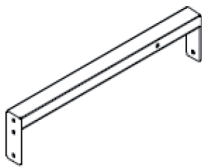
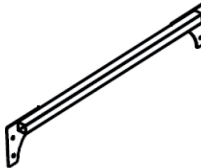
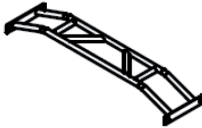

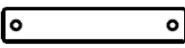
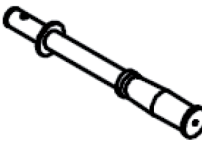
Transport des Gerätes

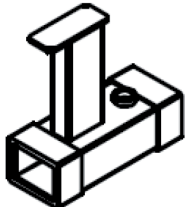
Bitte bewahren Sie die Originalverpackung auf. Um einen ausreichender Schutz beim Transport des Gerätes zu erreichen, verpacken Sie das Gerät in der Originalverpackung.











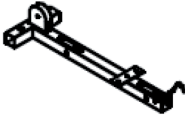

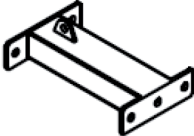

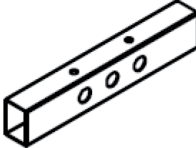

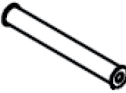

Reinigung der äußeren Oberfläche

Verwenden Sie keine flüchtigen Flüssigkeiten, wie Insektensprays. Durch zu starken Druck beim Abwischen können die Oberflächen beschädigt werden.

BAUTEILE HAUPTGERÄT

			
A 1x	B 1x	C 2x	D 1x
			
E 1x	F 1x	G 4x	H 2x
			
I 2x	J 1x	K 1x	L 4x
 			
M 2x	1 8x Schraube (M12x90), Unterlegscheiben, Mutter	2 8x Schraube (M12x95), Unterlegscheiben, Mutter	3 8x Schraube (M12x75), Unterlegscheiben, Mutter
			
4 2x Pin (8x40 mm)	R 8x Pin M20		

BAUTEILE LAT-ZUG (NUR 10027847)

			
IA 1x	IB 1x	IC 1x	ID 1x
			
IE 1x	IF 1x	IG 1x	IH 2x
			
II 2x	IJ 2x	IK 2x	
			
1 2x Schraube (M10x25), Unterlegscheibe, Mutter	2 4x Schraube (M10x45), Unterlegscheiben, Mutter	3 5x Schraube (M10x70), Unterlegscheiben, Mutter	4 2x Schraube (M10x90), Unterlegscheiben, Mutter
			
5 2x Pin (8x40 mm)	6 6x	7 4x	8 4x

MONTAGE

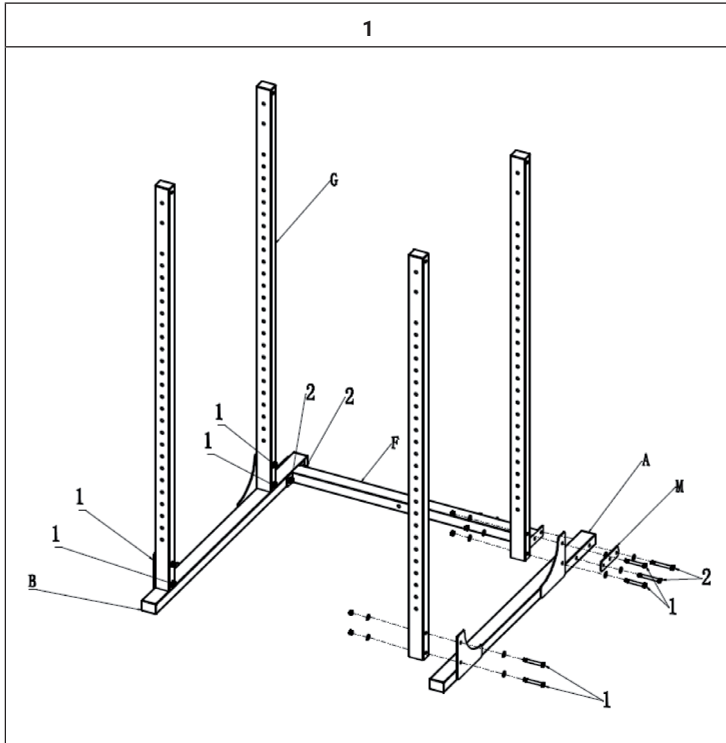

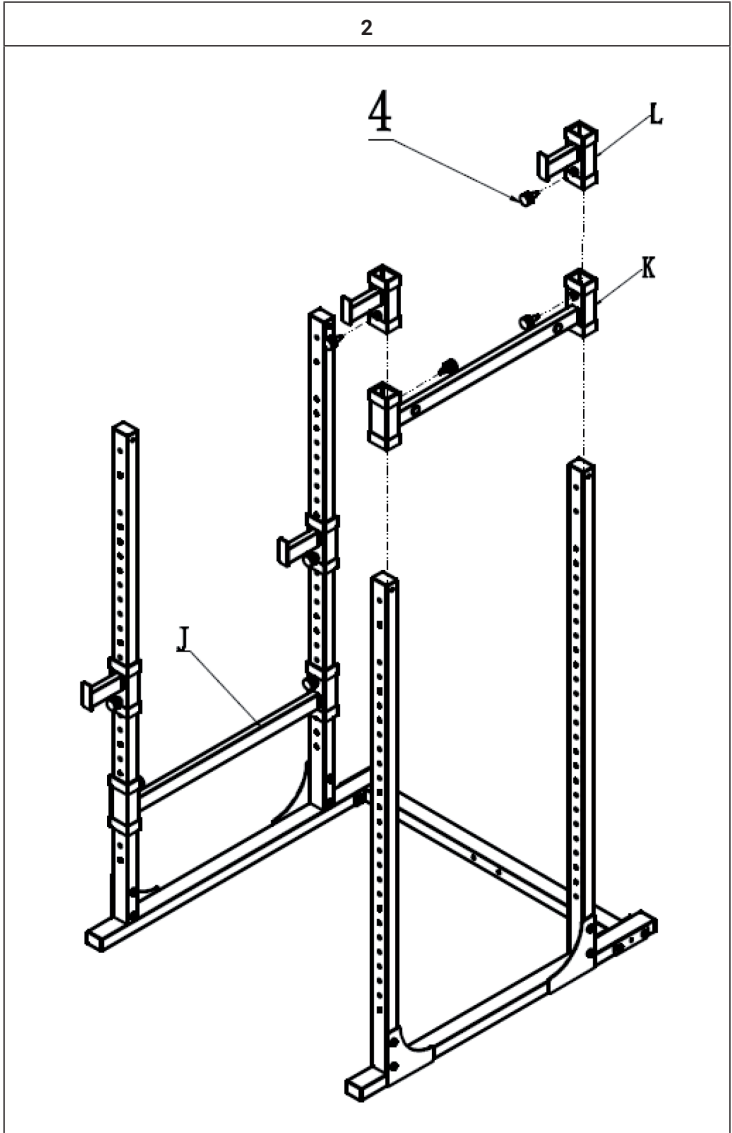

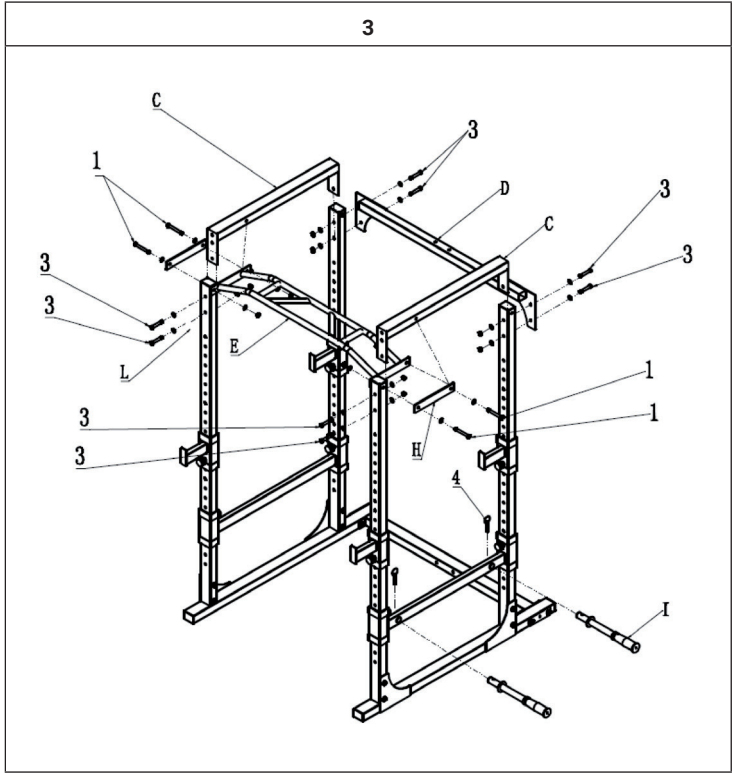

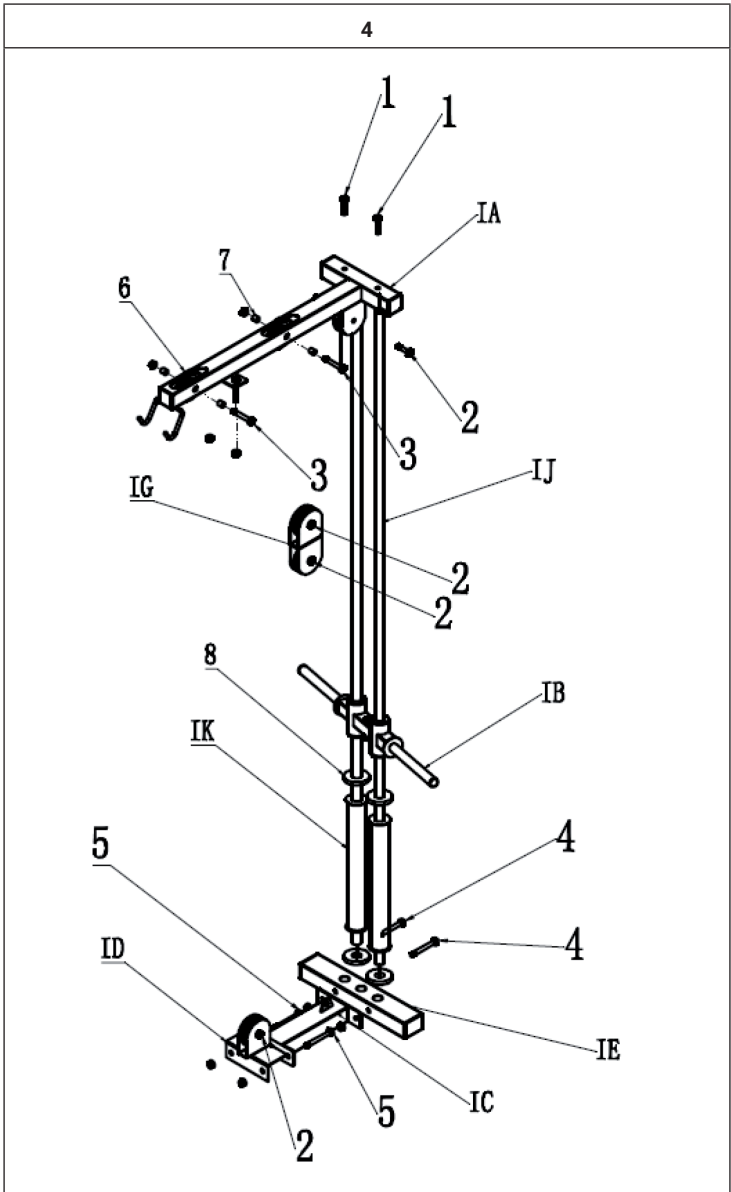



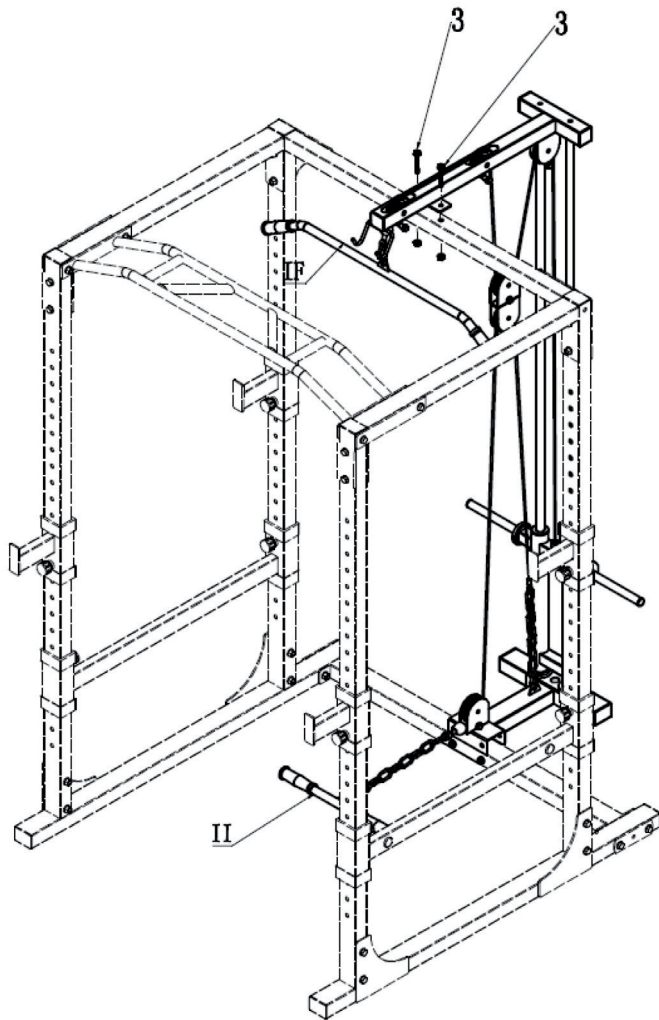

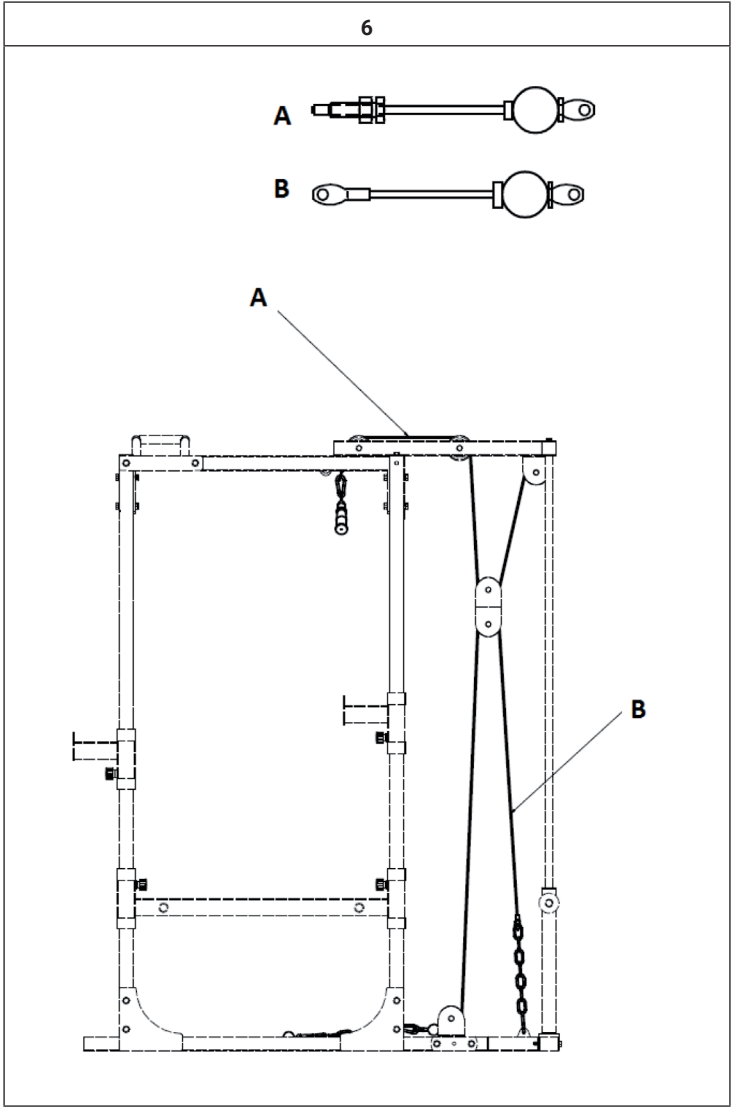



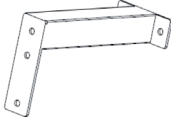
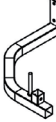

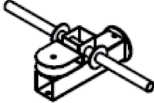



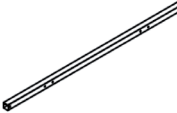

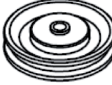











5





BAUTEILE KABELZUG (NUR 10027846)

			
1 x2	2 x1	3 x1	4 x2
			
5 x4	6 x2	7 x2	8 x1
			
9 x1	10 x1	11 x8	12 x4
			
13 x2	M12 x 100 14 x4	M12 x 75 15 x8	M12 x 70 16 x4
			
M10 x 65 17 x6	M10 x 45 18 x8	M12 19 x24	M10 20 x14
			
M12 21 x12	M10 22 x6	M16 23 x4	M16 24 x4
			
25 x4	26 x12	27 x6	28 x4
			
29 x4	30 x2	31 x2	

MONTAGE DES KABELZUGS

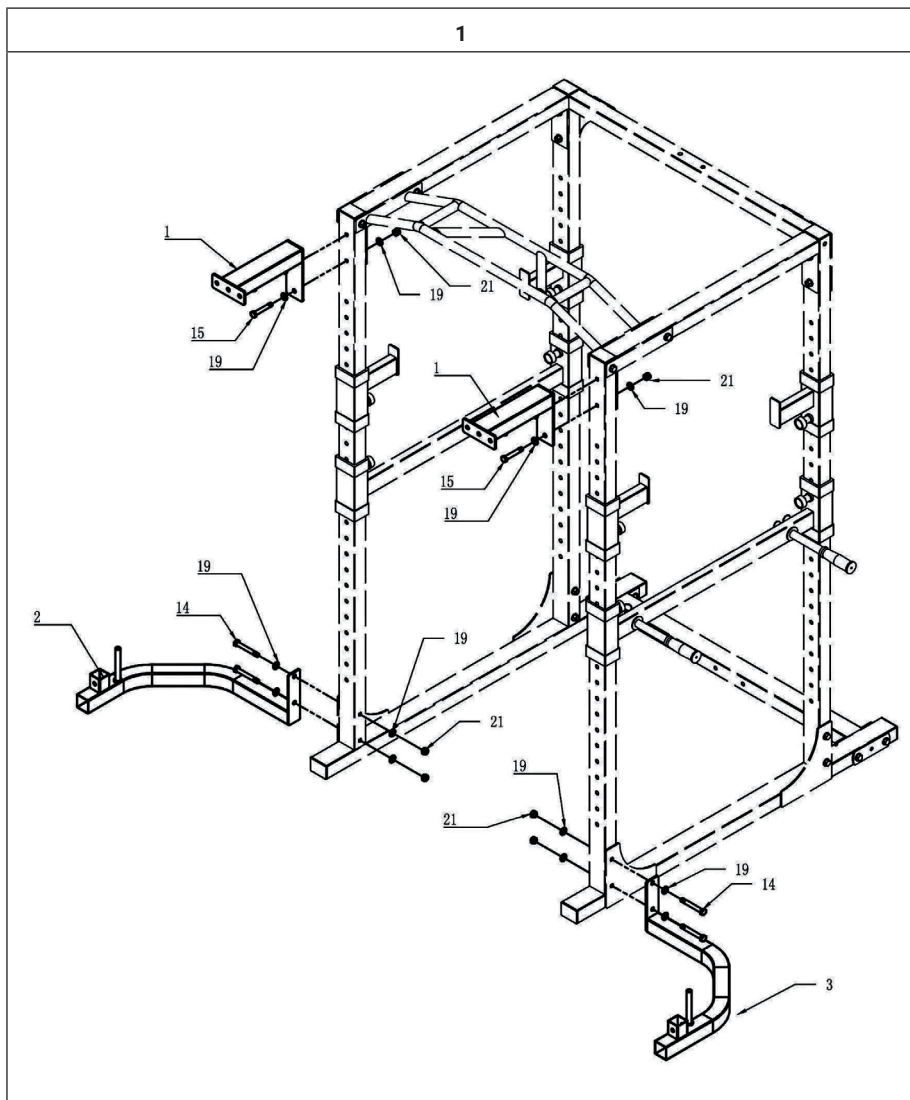

2

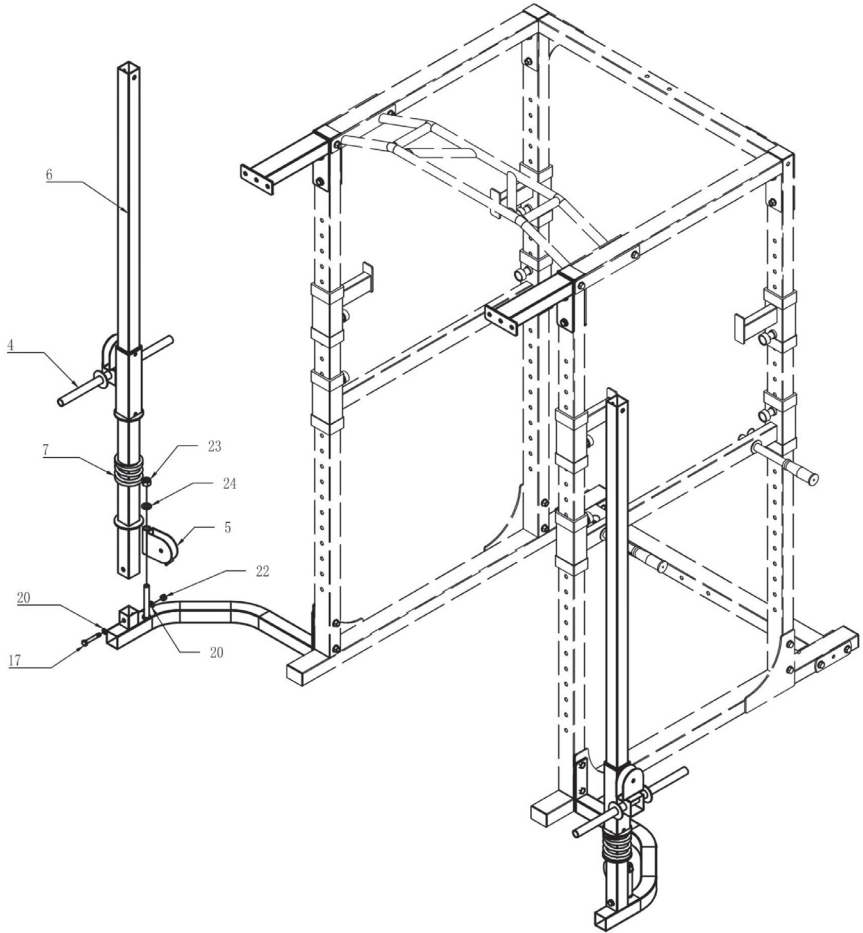

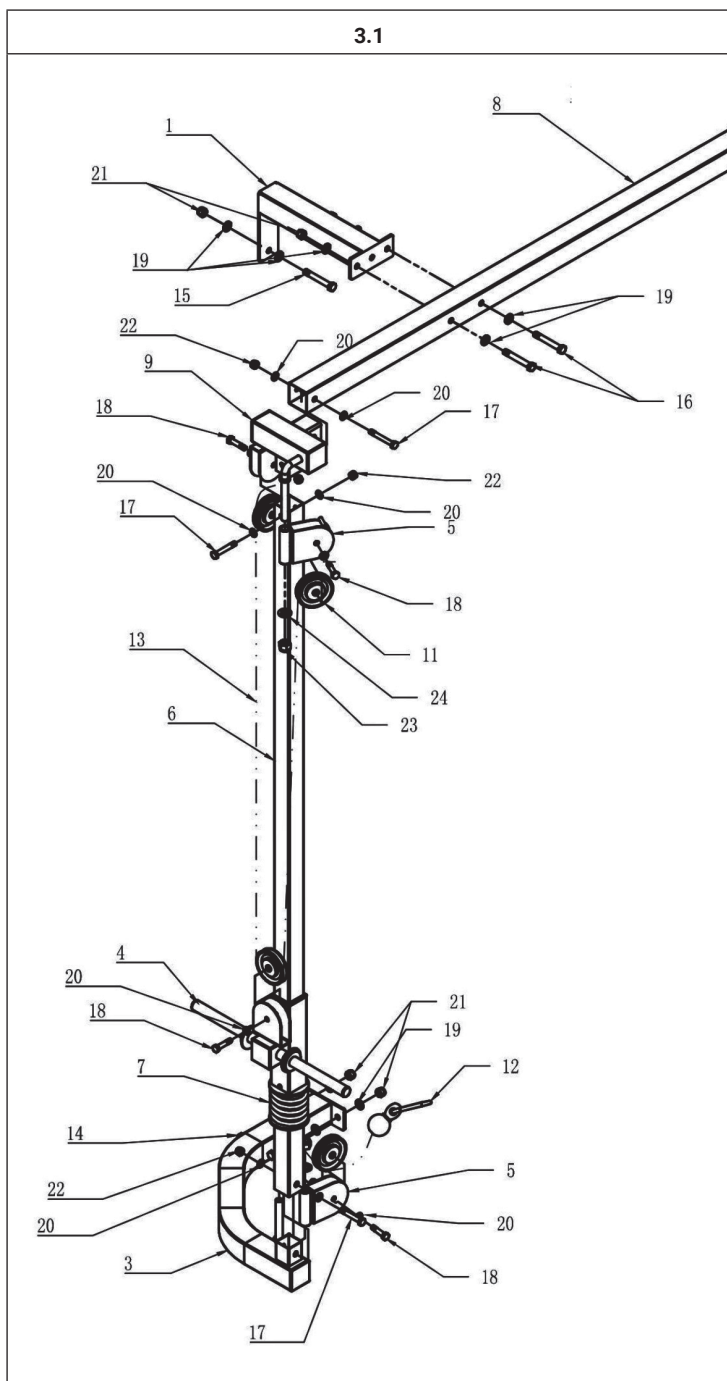

3.2

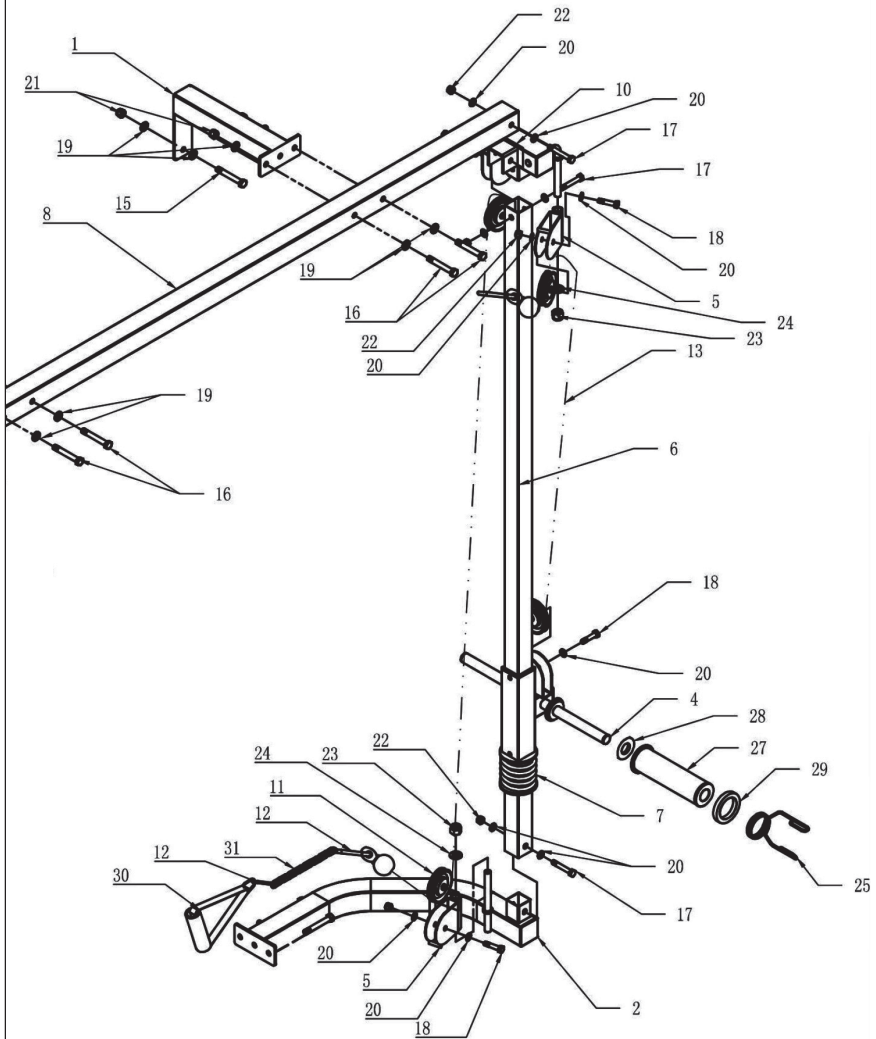

Dear Customer,

Congratulations on purchasing this device. Please read the following instructions carefully and follow them to prevent possible damages. We assume no liability for damage caused by disregard of the instructions and improper use. Scan the QR code to get access to the latest user manual and more product information.



IMPORTANT SAFETY INSTRUCTIONS

1. Read these operating instructions carefully before installing and using the device. Safe and effective use of the appliance can only be achieved if the appliance is properly set up, maintained and used. Make sure that all persons using this appliance are aware of the warnings and safety instructions.
2. If you are taking medication that affects blood pressure, heartbeat or cholesterol levels, consult a physician before exercising.
3. Pay attention to the signals from your body. Incorrect or excessive exercise can be harmful to your health. Stop exercising immediately if you experience any of the following symptoms: pain / tightness in the chest, irregular heartbeat, extreme shortness of breath, signs of lightheadedness, dizziness or nausea. If you experience any of these symptoms, you should consult a physician before continuing training.
4. This device is not intended for use by persons (including children) with reduced physical, sensory or mental abilities or lack of experience and/or knowledge, unless they are supervised by or receive instructions from a person responsible for their safety. Children should be supervised to ensure that they do not play with the device.
5. Make sure that all screws and fasteners are properly tightened before each workout.
6. The safety of the device can only be guaranteed if the device is regularly maintained and checked for any damage or wear and tear.

7. Use The Device Only As Intended. If You Discover Defective Components During Assembly Or Inspection Or If You Notice Unusual Noises On The Device During Training, Stop Training Immediately. Only Use The Device Again After The Problem Has Been Identified And Solved.
8. Wear Appropriate Clothing When Using The Device. Avoid Loose Clothing That May Get Caught On The Device And Restrict Your Freedom Of Movement.
9. The Device Has Been Tested And Certified According To En 957 And Is Approved For Domestic Use. The Maximum User Weight Should Not Exceed 120 kg.
10. The Device Is Not Suitable For Therapeutic Use.

Small objects/packaging parts

(plastic bags, cardboard, etc.)

Keep small objects (e.g. screws and other assembly materials) and packaging parts out of the reach of children so that they cannot be swallowed by them. Do not let small children play with foil. There is a danger of suffocation!









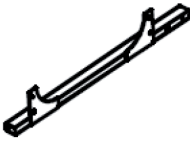
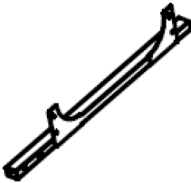
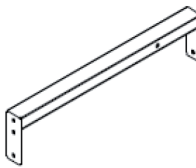
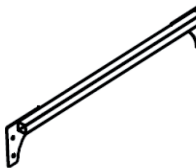
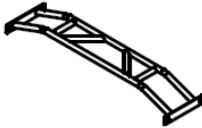

Intended use

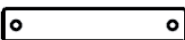
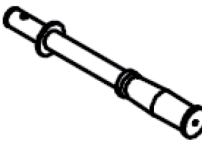
This device is used for physical muscle training by performing pull-ups and similar exercises. It is intended exclusively for this purpose and may only be used for this purpose. It may only be used in the manner described in this user manual.

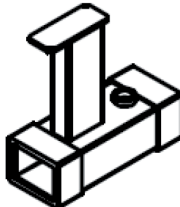









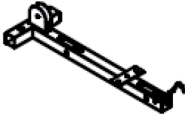

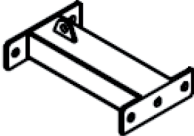

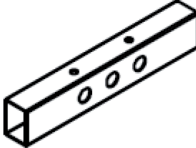

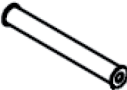

Transport of the device

Please keep the original packaging. To ensure adequate protection when transporting the device, pack the device in its original packaging.

COMPONENTS MAIN UNIT

 <p>A 1x</p>	 <p>B 1x</p>	 <p>C 2x</p>	 <p>D 1x</p>
 <p>E 1x</p>	 <p>F 1x</p>	 <p>G 4x</p>	 <p>H 2x</p>
 <p>I 2x</p>	 <p>J 1x</p>	 <p>K 1x</p>	 <p>L 4x</p>
 <p>M 2x</p>	 <p>1 8x Screw (M12x90), washers, nut</p>	 <p>2 8x Screw (M12x95), washers, nut</p>	 <p>3 8x Screw (M12x75), washers, nut</p>
 <p>4 2x Pin (8x40 mm)</p>	 <p>R 8x Pin M20</p>		

COMPONENTS LAT (ONLY 10027847)

			
IA 1x	IB 1x	IC 1x	ID 1x
			
IE 1x	IF 1x	IG 1x	IH 2x
			
II 2x	IJ 2x	IK 2x	
			
1 2x Screw (M10x25), washer, nut	2 4x Screw (M10x45), washers, nut	3 5x Screw (M10x70), washers, nut	4 2x Screw (M10x90), washers, nut
			
5 2x Screw (M10x95 mm)	6 6x	7 4x	8 4x

ASSEMBLY

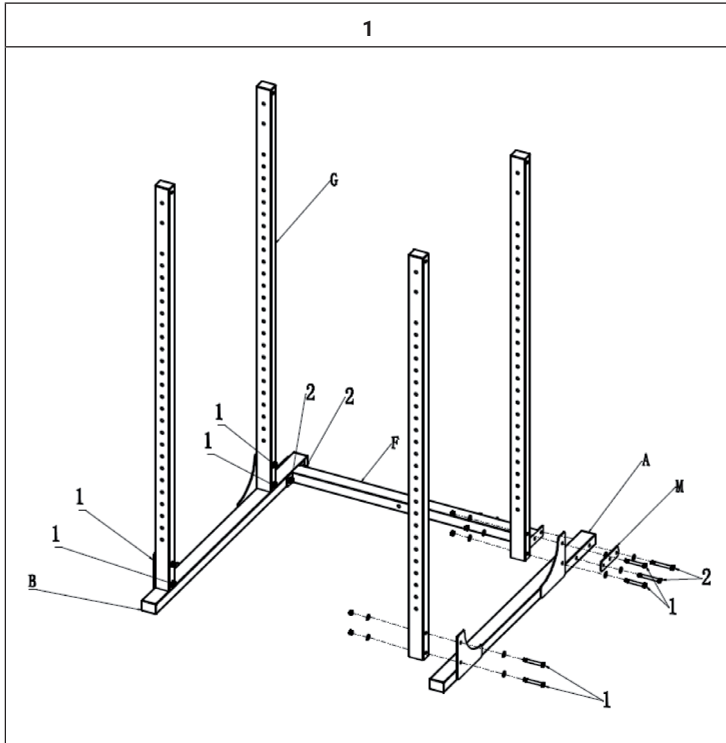

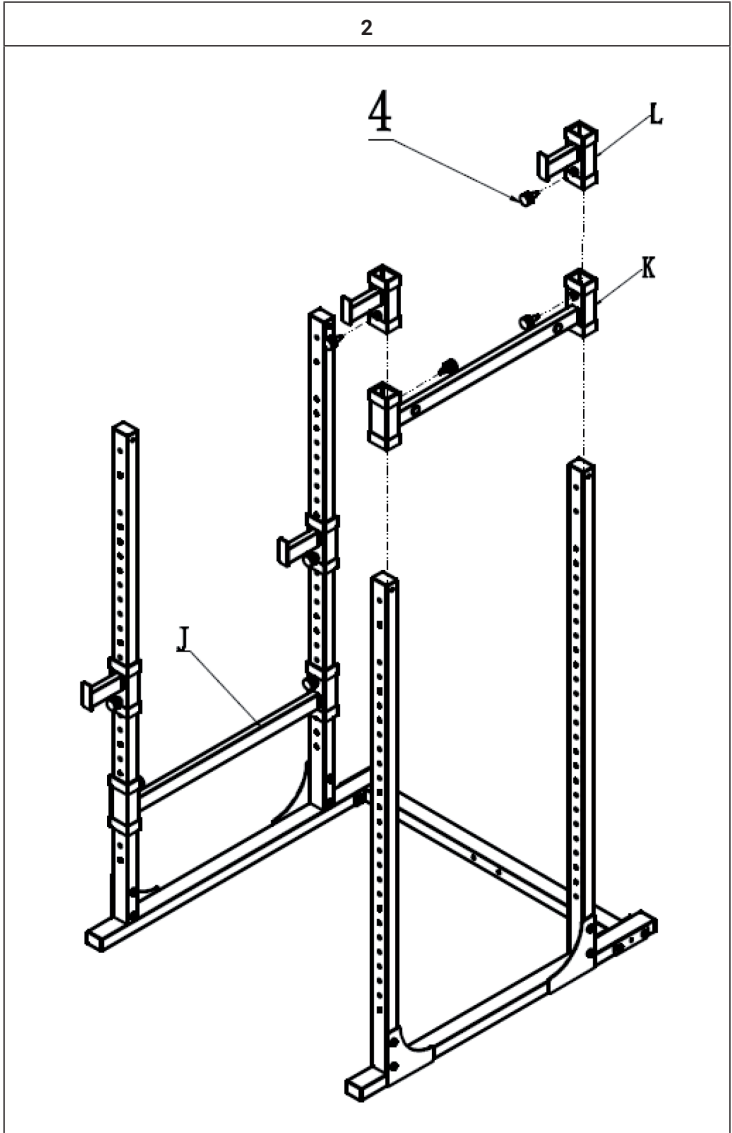

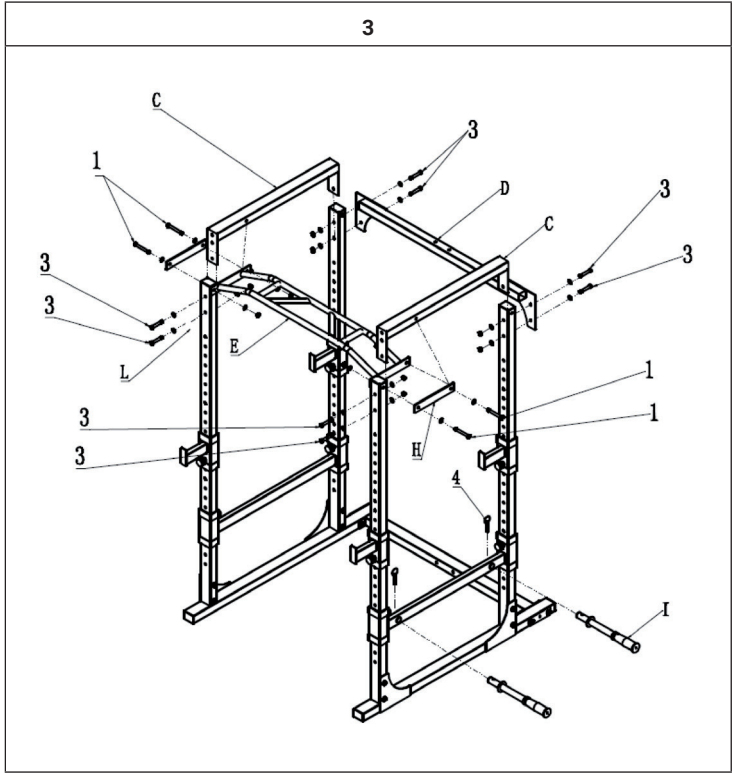

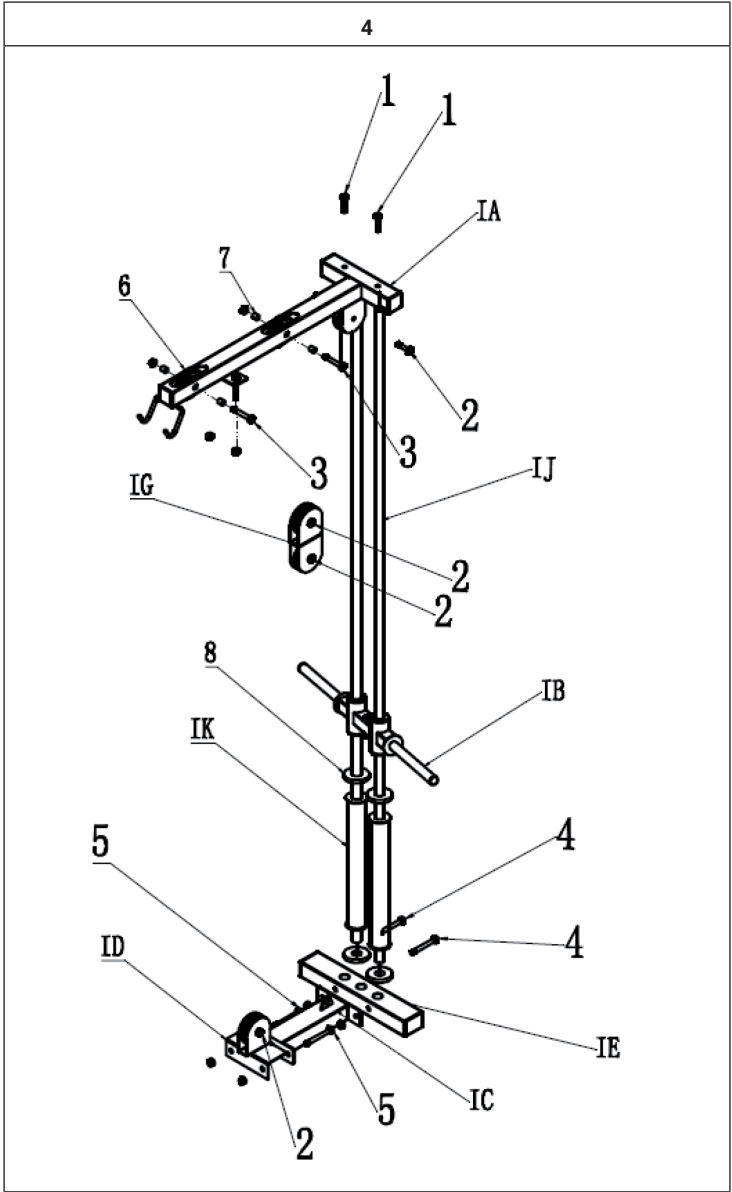



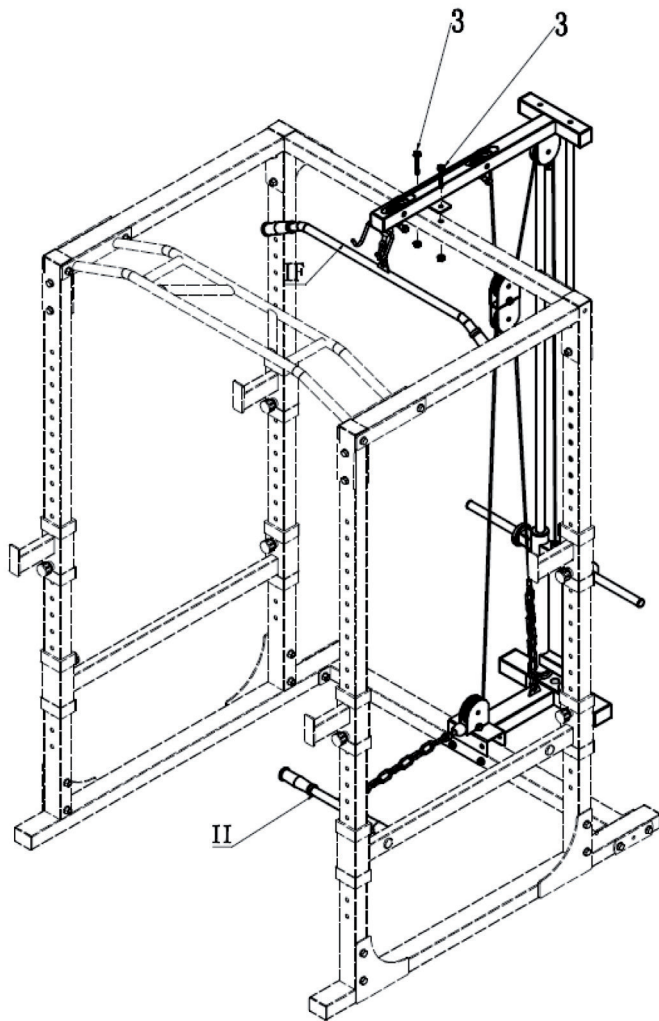



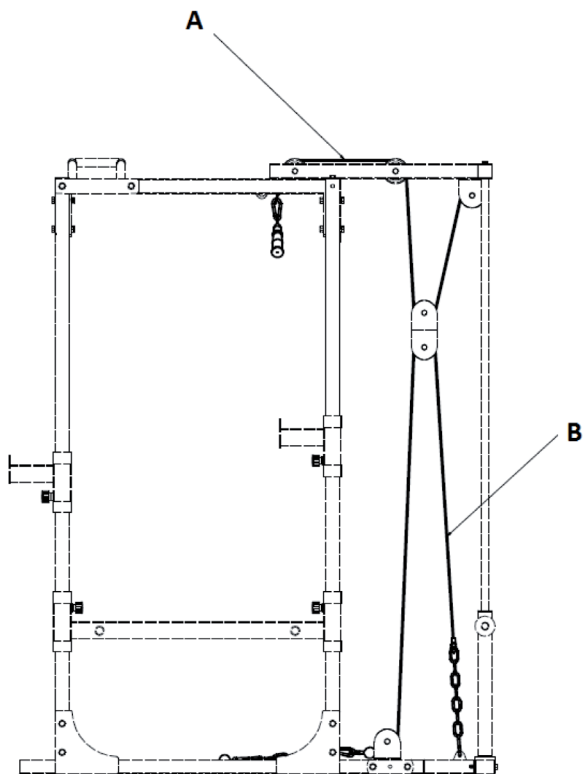
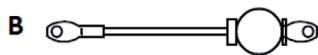
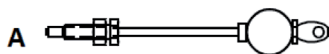



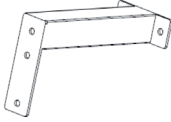
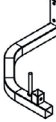

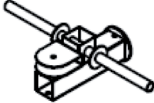



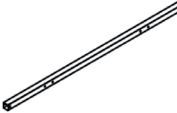

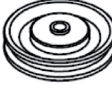









5



6



CABLE PULL COMPONENTS (10027846 ONLY)

			
1 x2	2 x1	3 x1	4 x2
			
5 x4	6 x2	7 x2	8 x1
			
9 x1	10 x1	11 x8	12 x4
			
13 x2	M12 x 100 14 x4	M12 x 75 15 x8	M12 x 70 16 x4
			
M10 x 65 17 x6	M10 x 45 18 x8	M12 19 x24	M10 20 x14
			
M12 21 x12	M10 22 x6	M16 23 x4	M16 24 x4
			
25 x4	26 x12	27 x6	28 x4
			
29 x4	30 x2	31 x2	

CABLE PULL ASSEMBLY

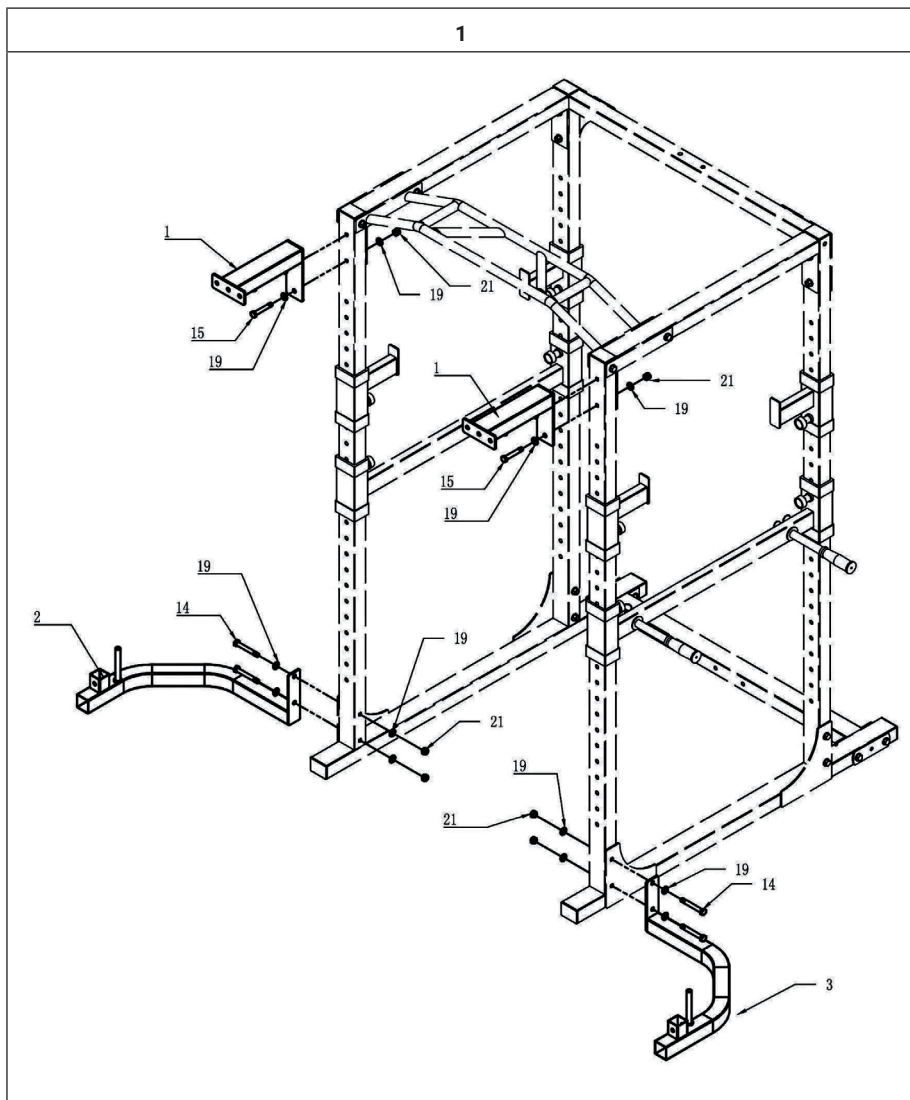

2

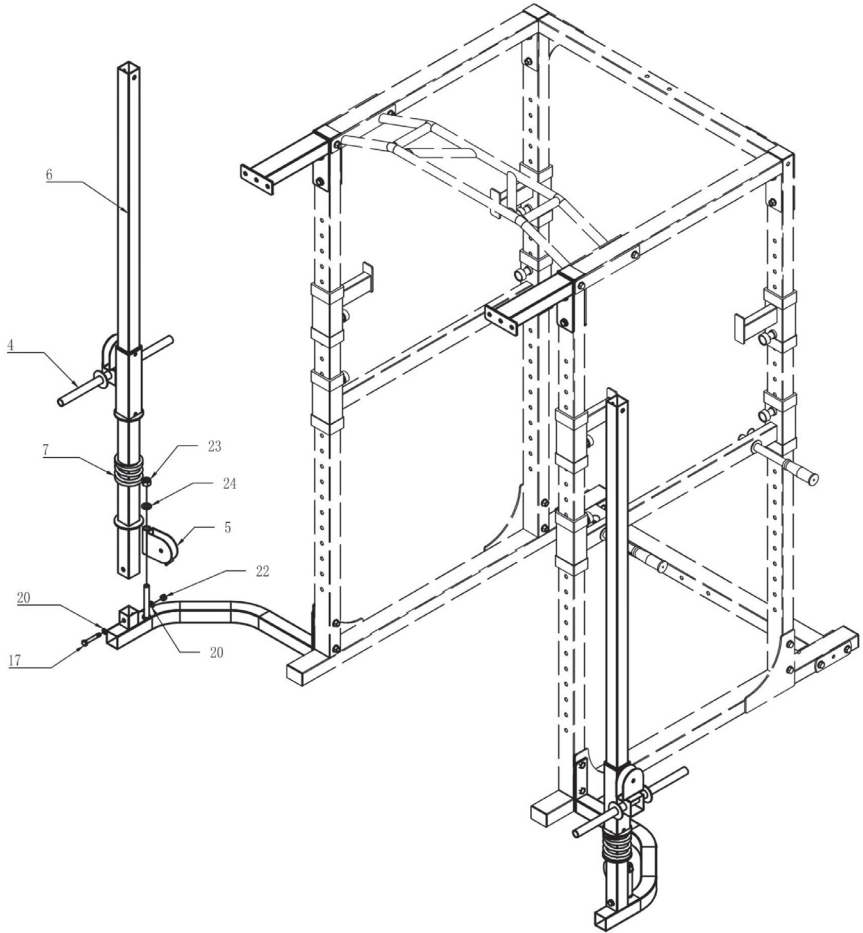

3.1

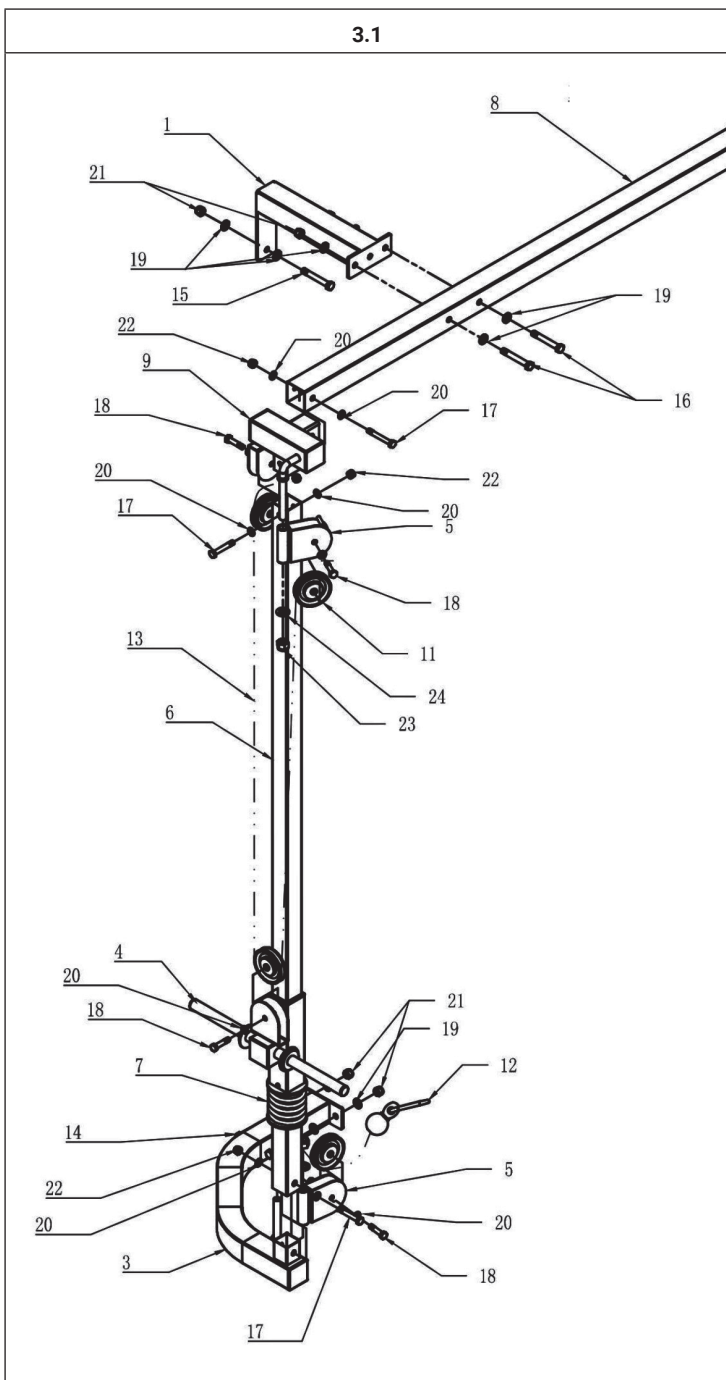

3.2

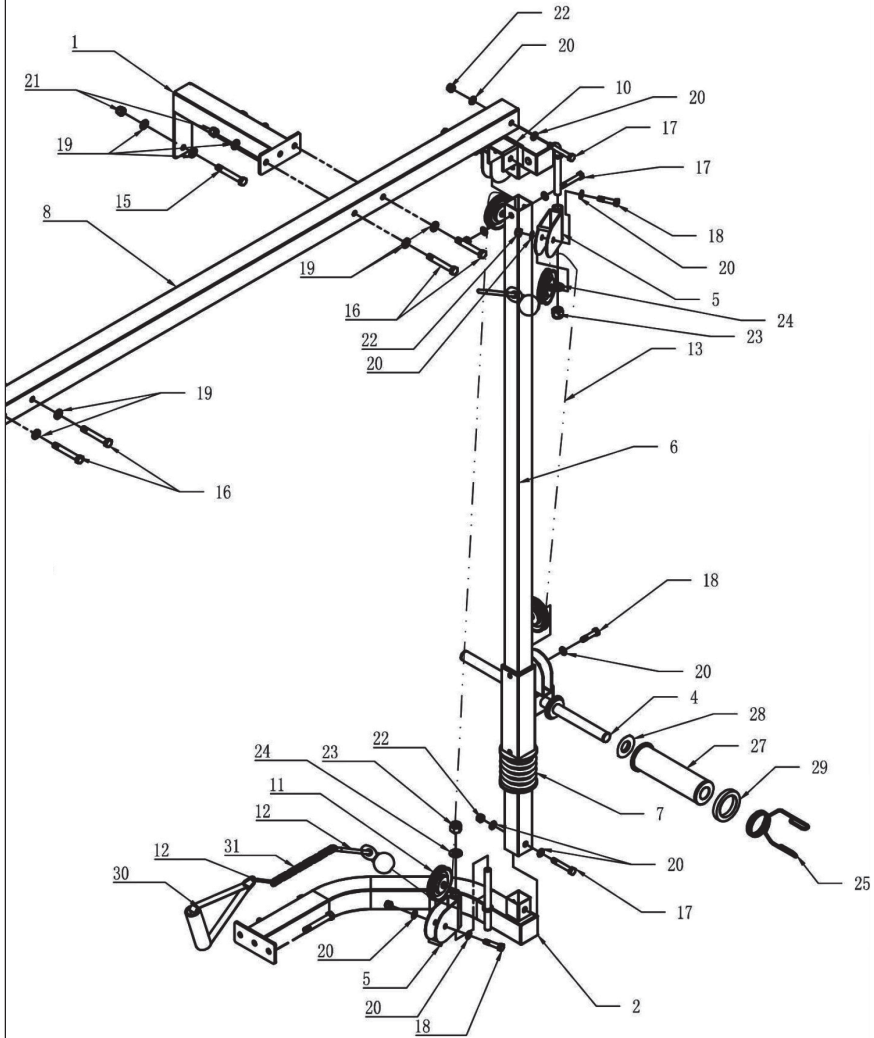

Estimado cliente:

Le felicitamos por la adquisición de este producto. Lea atentamente el siguiente manual y siga cuidadosamente las instrucciones de uso con el fin de evitar posibles daños. La empresa no se hace responsable por los daños causados por el incumplimiento de las instrucciones y el uso indebido. Escanee el siguiente código QR para acceder al último manual de usuario y a más información sobre el producto.



INDICACIONES DE SEGURIDAD IMPORTANTES

1. Lea atentamente este manual de instrucciones antes de instalar y utilizar el aparato. Sólo se garantizará un uso seguro y eficaz del aparato si se configura, mantiene y utiliza correctamente. Asegúrese de que todas las personas que utilicen este aparato conozcan las advertencias e instrucciones de seguridad.
2. Si está tomando medicamentos que afectan a la presión arterial, la frecuencia cardíaca o los niveles de colesterol, se recomienda encarecidamente consultar con un médico antes de hacer ejercicio.
3. Preste atención a las señales de su cuerpo. Un entrenamiento incorrecto o excesivo puede ser perjudicial para su salud. Detenga el entrenamiento inmediatamente si experimenta alguno de los siguientes síntomas: dolor/ presión en el pecho, latidos cardíacos irregulares, dificultad extrema para respirar, signos de aturdimiento, mareos o náuseas. Si experimenta alguno de estos síntomas, debe consultar a un médico antes de continuar con el entrenamiento.
4. Este aparato no está diseñado para ser manejado por personas (incluidos niños) con discapacidades físicas, sensoriales o mentales o con falta de experiencia y/o conocimientos, salvo que estén supervisados por una persona responsable o hayan recibido instrucciones sobre cómo utilizar el aparato. Los niños deben estar bajo vigilancia para evitar que jueguen con el aparato.
5. Antes de cada sesión de entrenamiento, asegúrese de que todos los tornillos y fijaciones estén bien apretados.
6. La seguridad del aparato sólo puede garantizarse si se realiza un mantenimiento periódico del mismo y se inspecciona para detectar cualquier daño o signo de desgaste.

7. Utilice la unidad solo como está previsto. Si descubre algún componente defectuoso durante la puesta en marcha o la inspección, o si nota algún ruido inusual en el aparato durante el entrenamiento, detenga el entrenamiento inmediatamente. No vuelva a utilizar el aparato hasta que se haya identificado y solucionado el problema.
8. Utilice ropa adecuada cuando utilice la unidad. Evite la ropa suelta que pueda engancharse en el aparato y restringir su movimiento.
9. La unidad ha sido probada y certificada según la norma EN 957 y está aprobada para uso doméstico. El peso máximo del usuario no debe superar los 120 kg.
- 10 El aparato no es adecuado para uso terapéutico.

Objetos pequeños/piezas de embalaje

(bolsas de plástico, cartón, etc.)

Conserve las piezas pequeñas (p. ej., tornillos y otro material de montaje, tarjetas de memoria) y las piezas del embalaje fuera del alcance de los niños para evitar que se asfixien. No permita que los niños jueguen con los plásticos. ¡Existe peligro de asfixia!

Bestimmungsgemäßer Gebrauch

Esta máquina se utiliza para el entrenamiento físico de los músculos mediante la realización de dominadas y ejercicios similares. Está diseñado exclusivamente para este fin y no debe emplearse para ningún otro propósito. Sólo puede utilizarse de la manera descrita en estas instrucciones de uso.











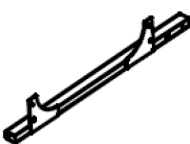
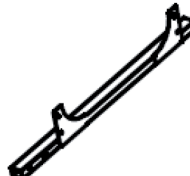
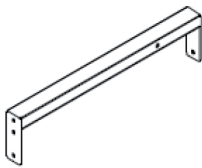
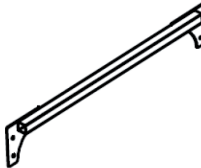
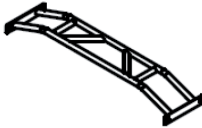



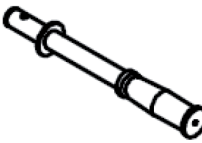

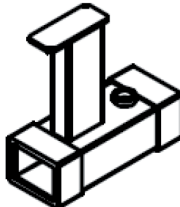
Transporte del aparato

Conserve el embalaje original. Para ofrecer suficiente protección durante el transporte, embale el aparato en su embalaje original.











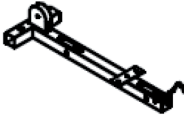

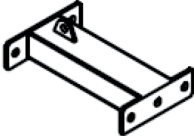

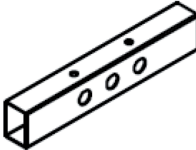

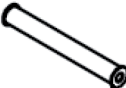

Limpieza de la superficie exterior

No utilice líquidos volátiles, como sprays para insectos. Si se ejerce una presión elevada al frotar se podrían dañar las superficies.

COMPONENTES DE LA UNIDAD PRINCIPAL

			
A 1x	B 1x	C 2x	D 1x
			
E 1x	F 1x	G 4x	H 2x
			
I 2x	J 1x	K 1x	L 4x
 	 	 	 
M 2x	1 8x Tornillo (M12x90), Arandelas, tuercas	2 8x Tornillo (M12x95) Arandelas, tuercas	3 8x Tornillo (M12x75) Arandelas, tuercas
			
4 2x Clavija (8x40 mm)	R 8x Clavija M20		

COMPONENTES LAT PULL (SÓLO 10027847)

 <p>IA 1x</p>	 <p>IB 1x</p>	 <p>IC 1x</p>	 <p>ID 1x</p>
 <p>IE 1x</p>	 <p>IF 1x</p>	 <p>IG 1x</p>	 <p>IH 2x</p>
 <p>II 2x</p>	 <p>IJ 2x</p>	 <p>IK 2x</p>	
 <p>1 2x Tornillo (M10x25) Arandelas, tuercas</p>	 <p>2 4x Tornillo (M10x45) Arandelas, tuercas</p>	 <p>3 6x Tornillo (M10x70) Arandelas, tuercas</p>	 <p>4 2x Tornillo (M10x90), Arandelas, tuercas</p>
 <p>5 2x Clavija (8x40 mm)</p>	 <p>6 6x</p>	 <p>7 4x</p>	 <p>8 4x</p>

MONTAJE

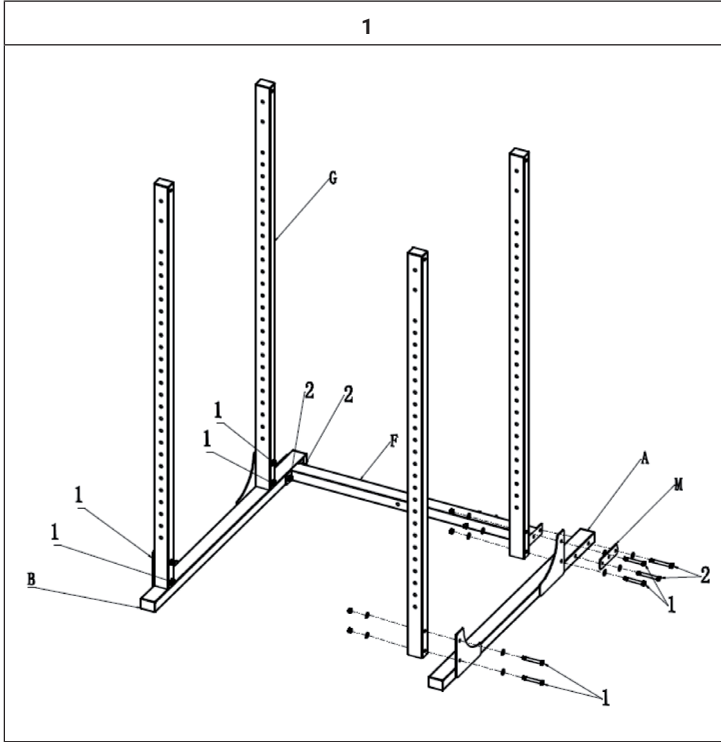

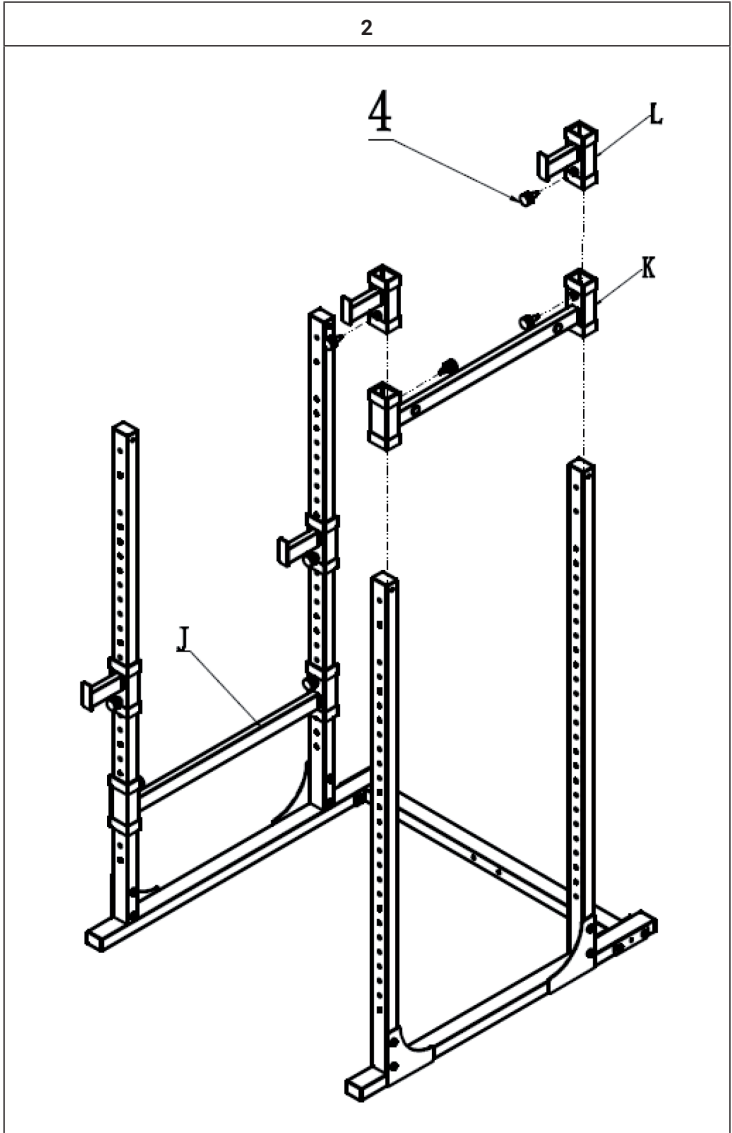

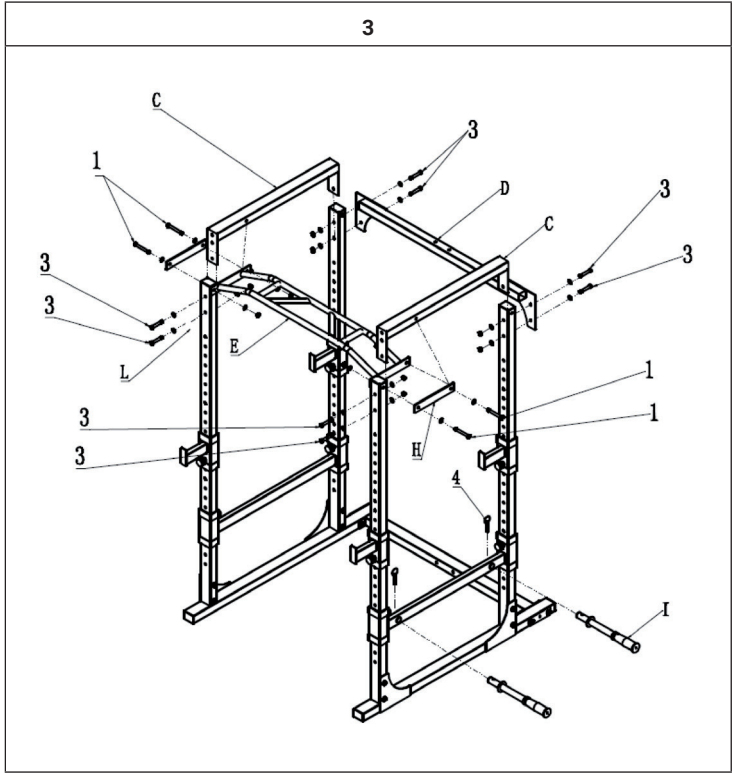

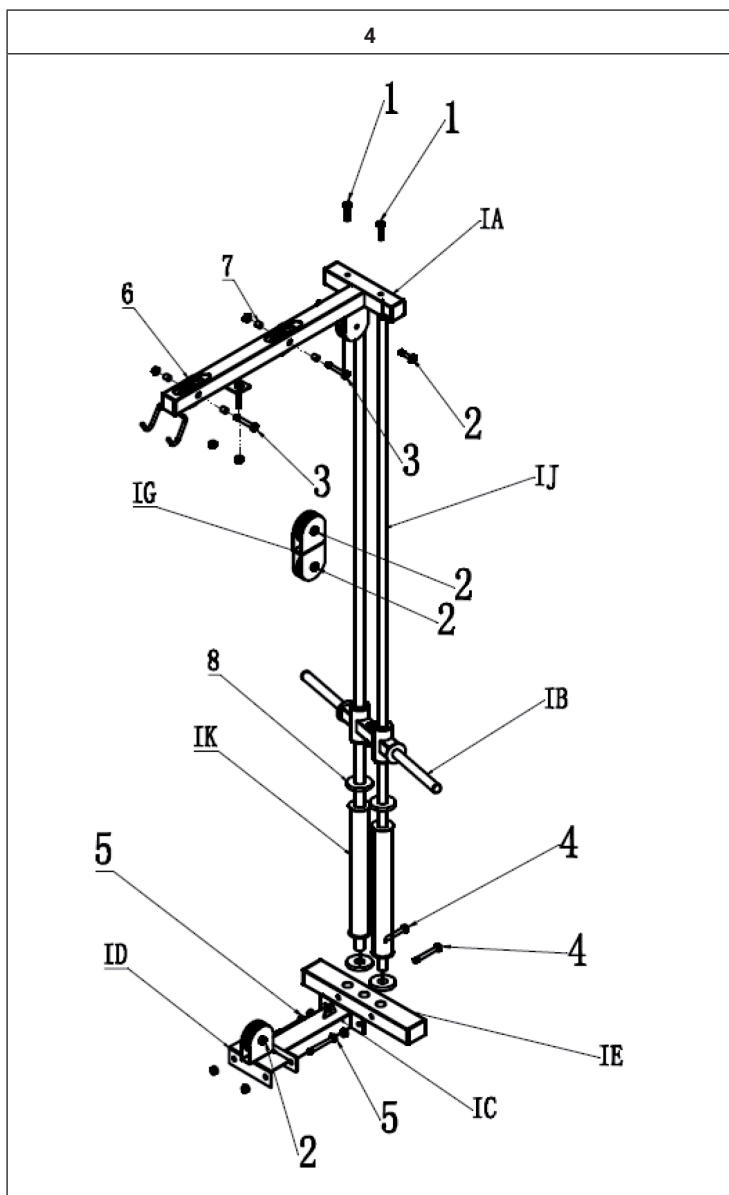

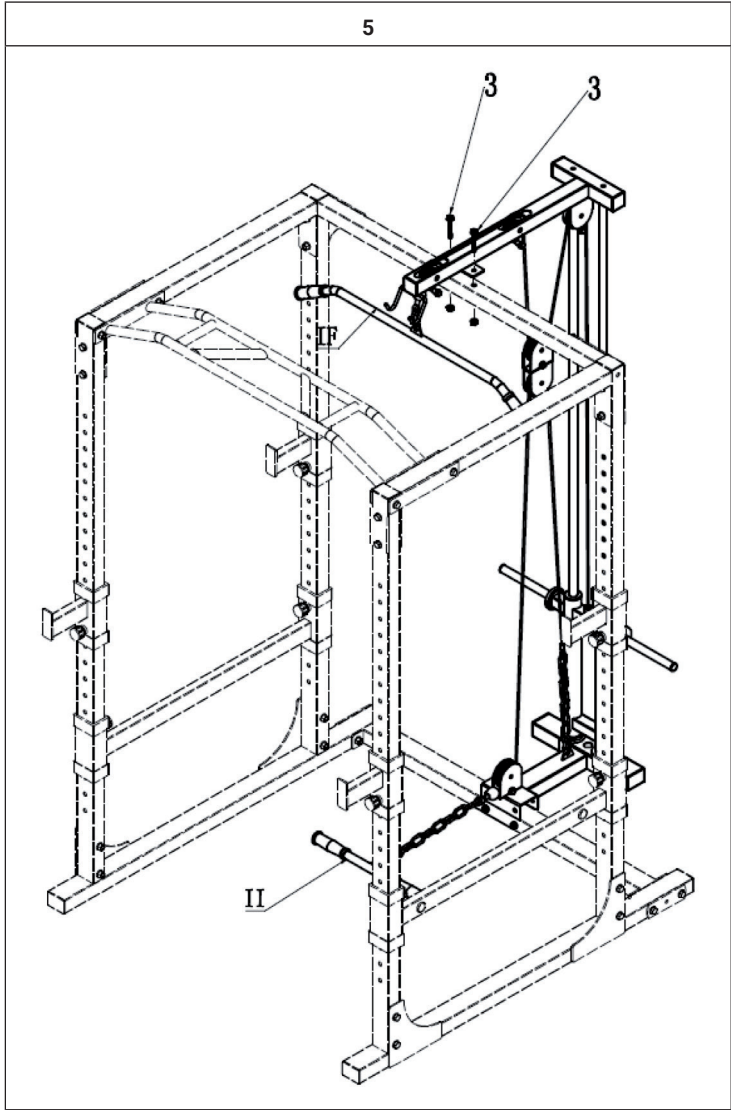

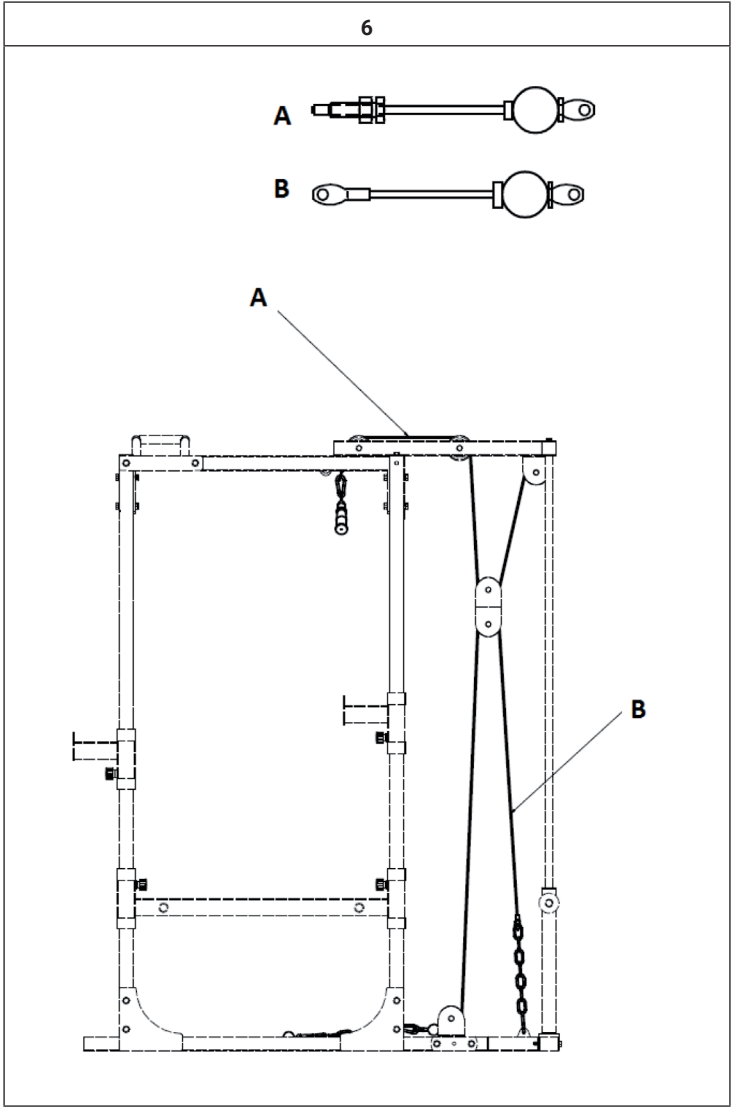



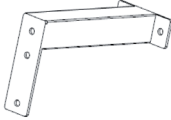
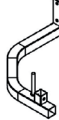

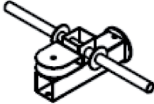



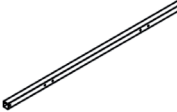



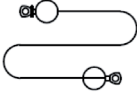















COMPONENTES DE TRACCIÓN DE CABLES (SÓLO 10027846)

			
1 x2	2 x1	3 x1	4 x2
			
5 x4	6 x2	7 x2	8 x1
			
9 x1	10 x1	11 x8	12 x4
			
13 x2	M12 x 100 x4	M12 x 75 x8	M12 x 70 x4
			
M10 x 65 x6	M10 x 45 x8	M12 x24	M10 x14
			
M12 x12	M10 x6	M16 x4	M16 x4
			
25 x4	26 x12	27 x6	28 x4
			
29 x4	30 x2	31 x2	

MONTAJE DEL TIRADOR DE CABLE

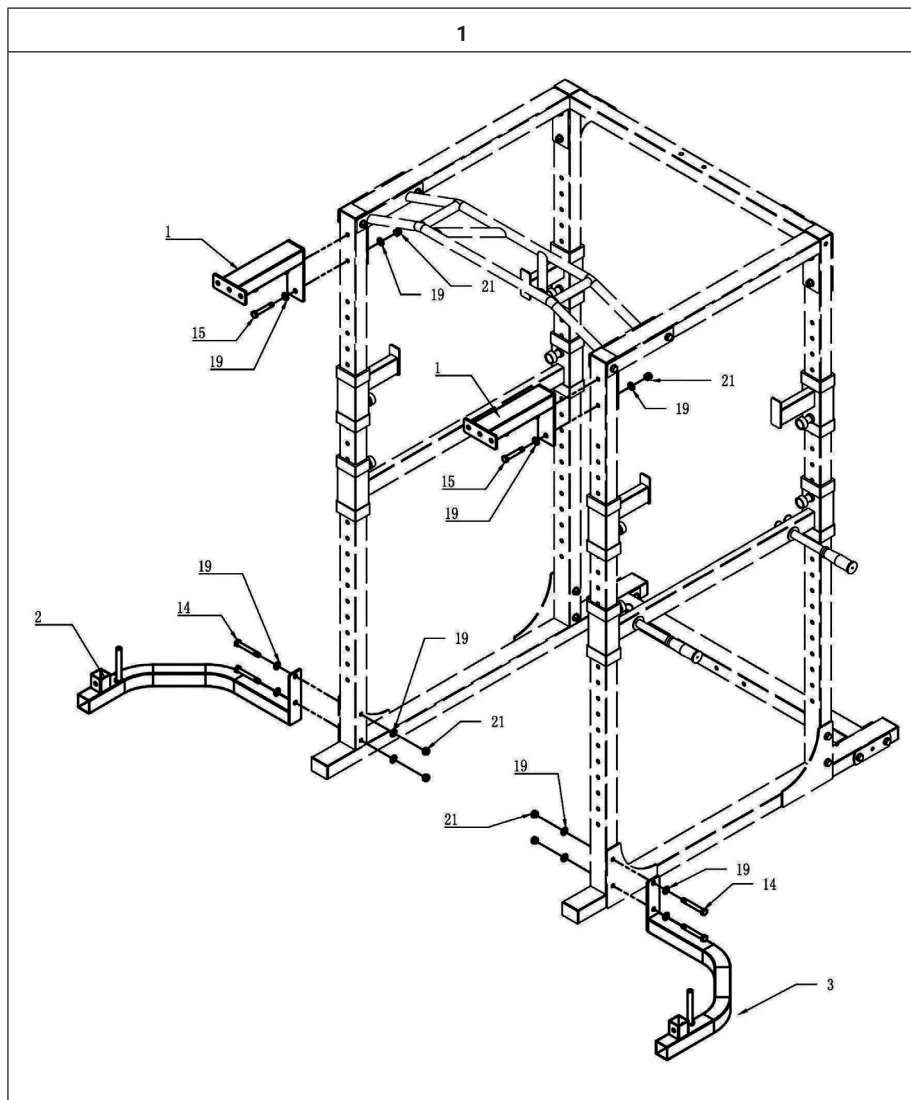

2

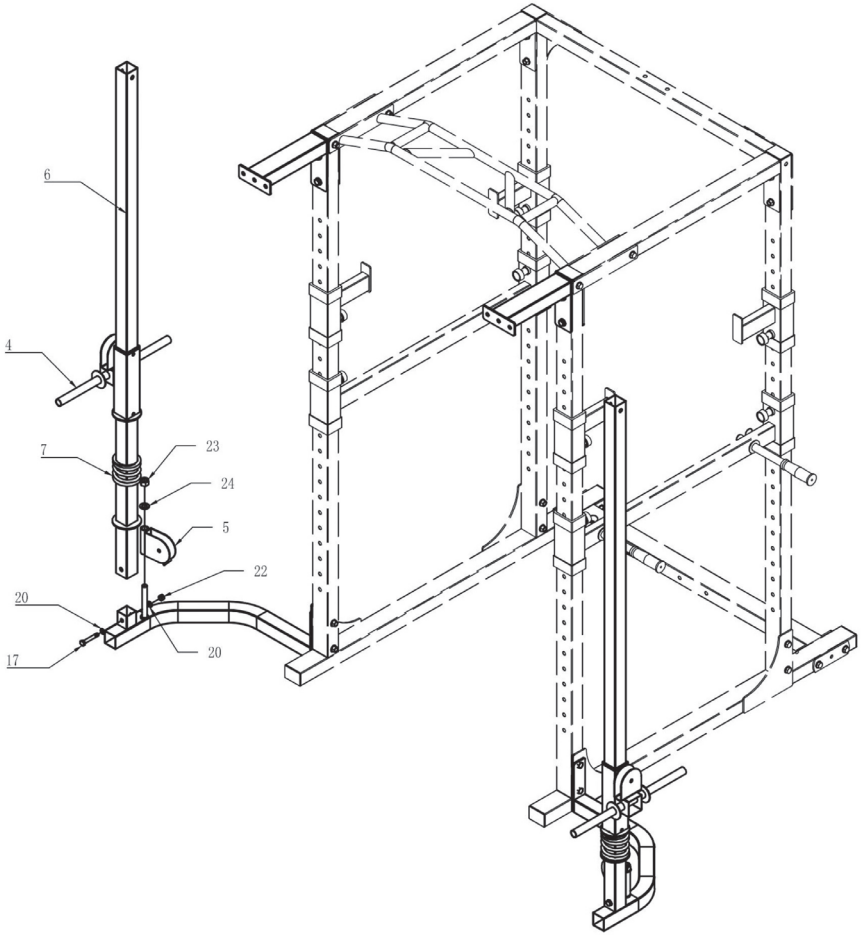

3.1

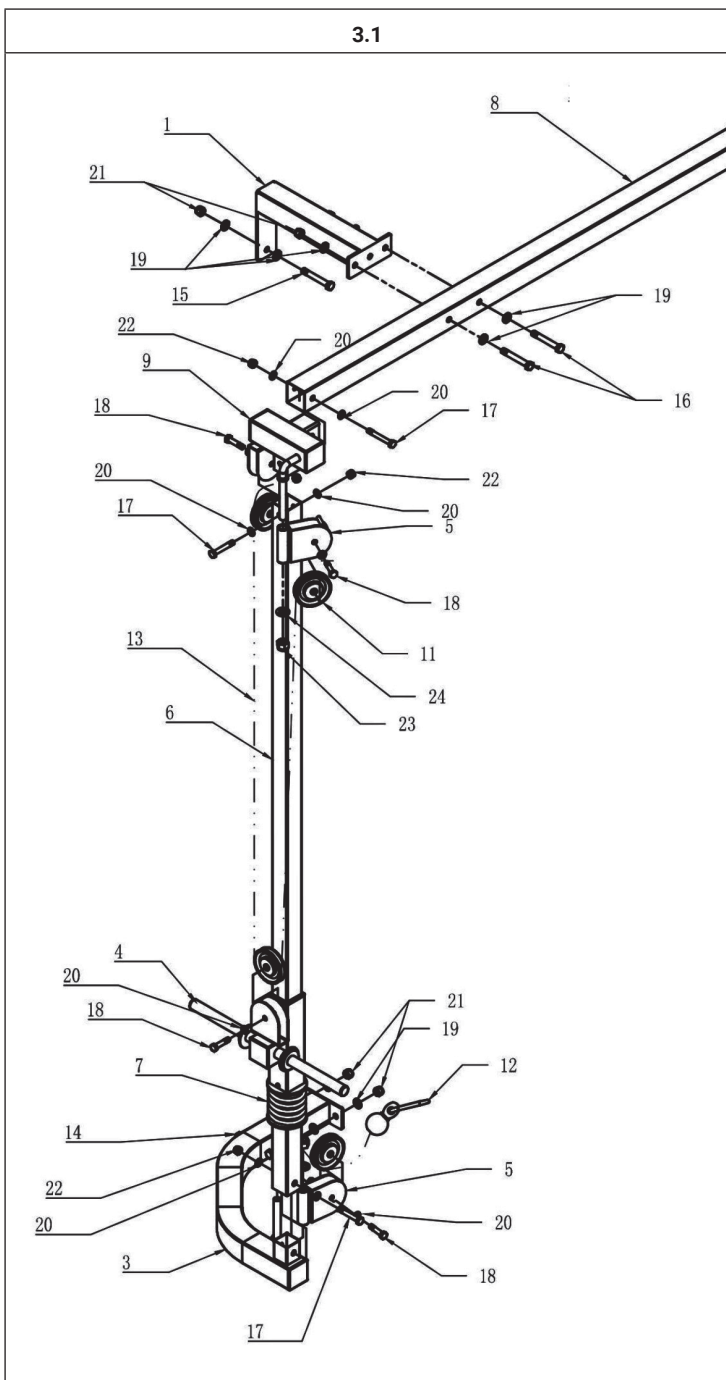

3.2

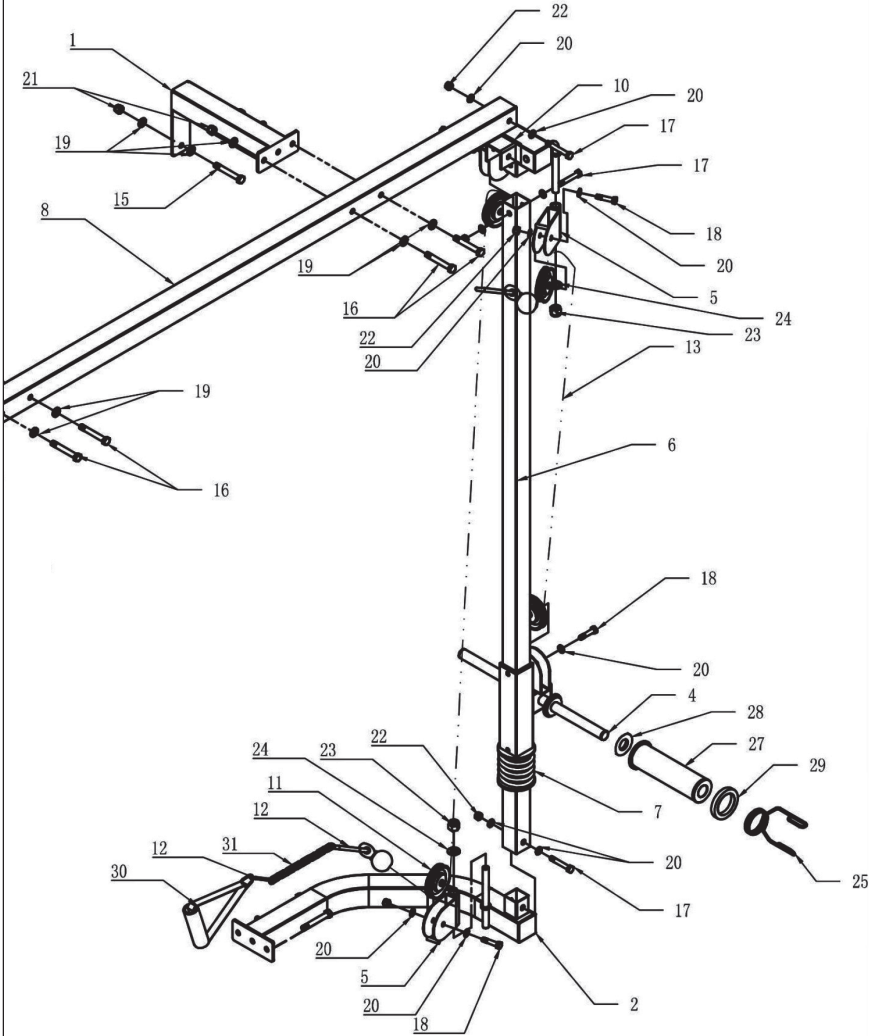

Cher client, chère cliente,

Toutes nos félicitations pour l'acquisition de ce nouvel appareil. Lisez attentivement les indications suivantes et suivez-les pour éviter d'éventuels dommages. Nous ne saurions être tenus pour responsables des dommages dus au non-respect des consignes et à la mauvaise utilisation de l'appareil. Scannez le QR-Code pour obtenir la dernière version du mode d'emploi ainsi que d'autres informations concernant le produit.



IMPORTANTES CONSIGNES DE SÉCURITÉ

1. Lisez attentivement ce mode d'emploi avant d'installer et d'utiliser l'appareil. Une utilisation sûre et efficace de l'appareil ne peut être obtenue que si l'appareil est correctement installé, entretenu et utilisé. Assurez-vous que toutes les personnes qui utilisent cet appareil ont pris connaissance des avertissements et des consignes de sécurité.
2. Si vous prenez des médicaments qui affectent la tension artérielle, le rythme cardiaque ou le taux de cholestérol, il est fortement conseillé de consulter un médecin avant de faire de l'exercice.
3. Prêtez attention aux signaux de votre corps. Un entraînement inadapté ou excessif peut nuire à votre santé. Arrêtez immédiatement de faire de l'exercice si vous ressentez l'un des symptômes suivants : douleur ou oppression thoracique, rythme cardiaque irrégulier, essoufflement extrême, signes d'étourdissement, vertiges ou nausées. Si vous ressentez l'un de ces symptômes, consultez un médecin avant de poursuivre l'entraînement.
4. Cet appareil n'est pas destiné à être utilisé par des personnes (y compris des enfants) ayant des capacités physiques, sensorielles ou mentales limitées ou dénuées d'expérience et/ou de connaissances, sauf sous surveillance ou après avoir été formées par un responsable de leur sécurité aux instructions et à la façon d'utiliser l'appareil. Surveillez les enfants pour qu'ils ne jouent pas avec l'appareil.
5. Avant chaque session d'entraînement, assurez-vous que toutes les vis et fixations sont correctement serrées.
6. La sécurité de l'appareil ne peut être garantie que s'il est régulièrement entretenu et inspecté pour détecter tout dommage ou signe d'usure.

7. Utilisez l'appareil uniquement comme prévu. Si vous découvrez des composants défectueux lors de l'installation ou de l'inspection, ou si vous remarquez des bruits inhabituels sur l'appareil pendant l'entraînement, arrêtez immédiatement l'entraînement. N'utilisez plus l'appareil tant que le problème n'a pas été identifié et résolu.
8. Portez des vêtements appropriés lorsque vous utilisez l'appareil. Évitez les vêtements amples qui pourraient s'accrocher à l'appareil et limiter vos mouvements.
9. L'appareil a été testé et certifié conformément à la norme EN 957 et est approuvé pour un usage domestique. Le poids maximal de l'utilisateur ne doit pas dépasser 120 kg.
10. L'appareil n'est pas adapté à un usage thérapeutique.

Petits objets/pièces d'emballage

(sacs en plastique, carton, etc.)

Conservez les petits objets (par ex. vis et autre matériel de montage, cartes mémoire) et les pièces d'emballage hors de portée des enfants afin qu'ils ne puissent pas les avaler. Ne laissez pas les jeunes enfants jouer avec les plastiques d'emballage. Il y a risque d'étouffement !

Utilisation prévue

Cet appareil sert à l'entraînement physique des muscles en effectuant des tractions et des exercices similaires. Il est destiné uniquement à cette fin et ne peut être utilisé qu'à cette fin. Il ne doit être utilisé que de la manière décrite dans ce mode d'emploi.











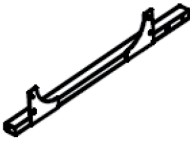
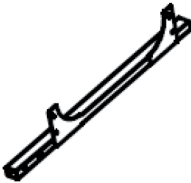
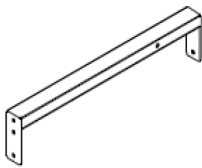
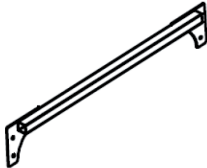
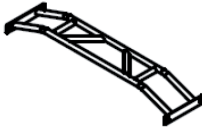



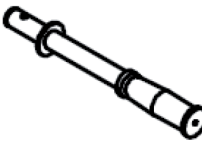

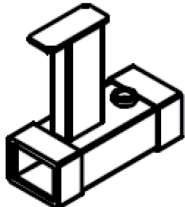
Transport de l'appareil

Transport de l'appareil : veuillez conserver l'emballage d'origine. Afin de fournir une protection adéquate lors du transport de l'appareil, remettez-le dans son emballage d'origine.











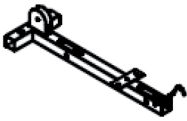

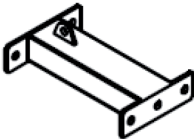

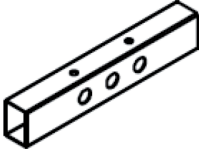

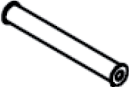

Nettoyage de la surface extérieure

N'utilisez pas de liquides volatils tels que des sprays insecticides. Une pression excessive lors de l'essuyage peut endommager les surfaces.

COMPOSANTS DE L'UNITÉ PRINCIPALE

			
A 1x	B 1x	C 2x	D 1x
			
E 1x	F 1x	G 4x	H 2x
			
I 2x	J 1x	K 1x	L 4x
 	 	 	 
M 2x	1 8x Vis (M12x90), Rondelles, écrous	2 8x Vis (M12x95), Rondelles, écrous	3 8x Vis (M12x75), Rondelles, écrous
			
4 2x Broche (8x40 mm)	R 8x Broche M20		

COMPOSANTS DE LA STATION DE TRACTIONS (SEULEMENT 10027847)

			
IA 1x	IB 1x	IC 1x	ID 1x
			
IE 1x	IF 1x	IG 1x	IH 2x
			
II 2x	IJ 2x	IK 2x	
			
Vis (M10x25), 1 Rondelles, écrous 2x	Vis (M10x45), 2 Rondelles, écrous 4x	Vis (M10x70), 3 Rondelles, écrous 8x	Vis (M10x90), 4 Rondelles, écrous 2x
			
Broche (8x40mm) 2x	6 6x	7 4x	8 4x

MONTAGE

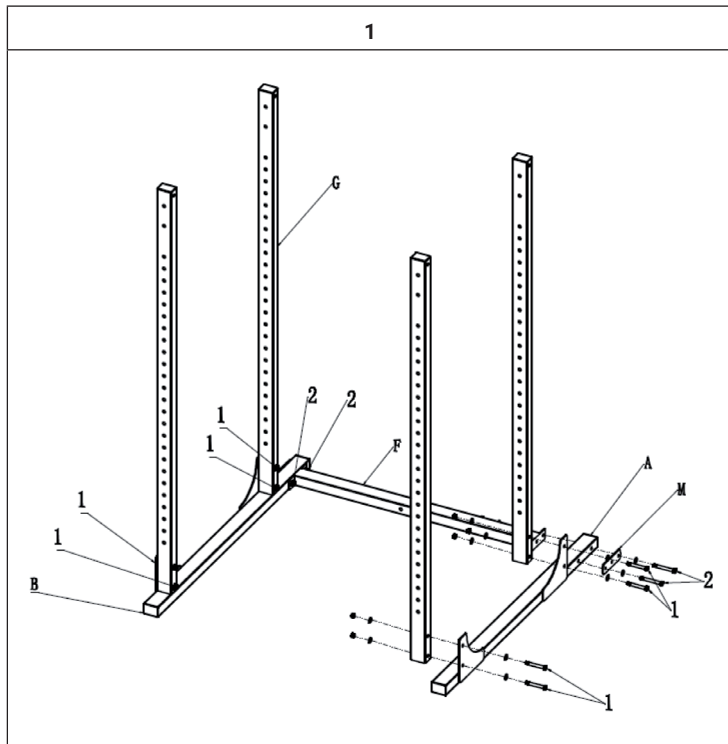

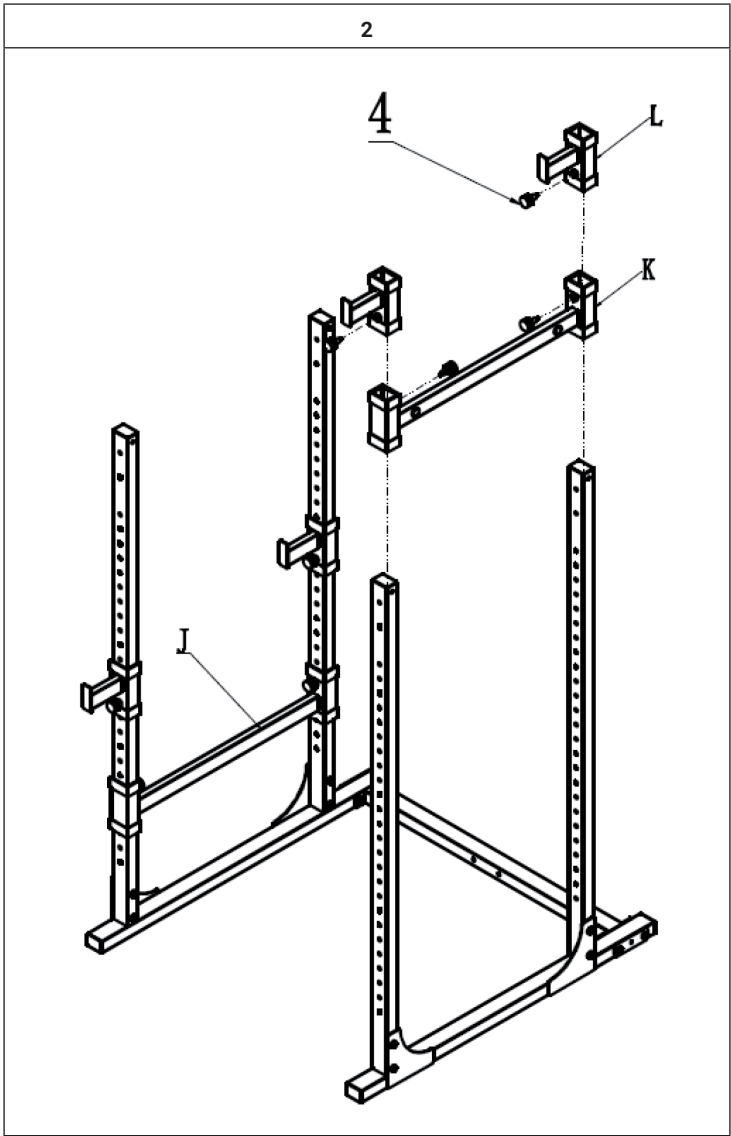

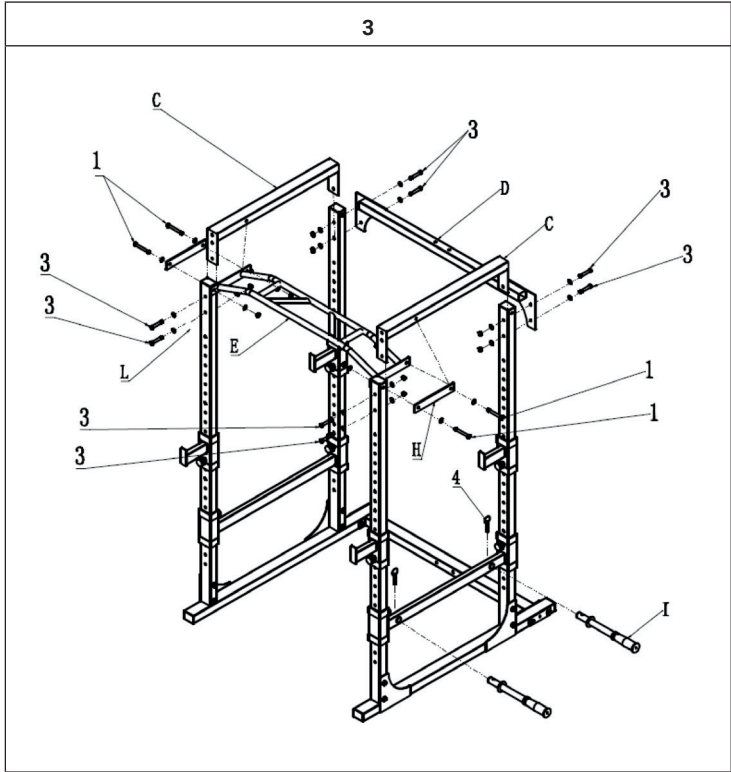

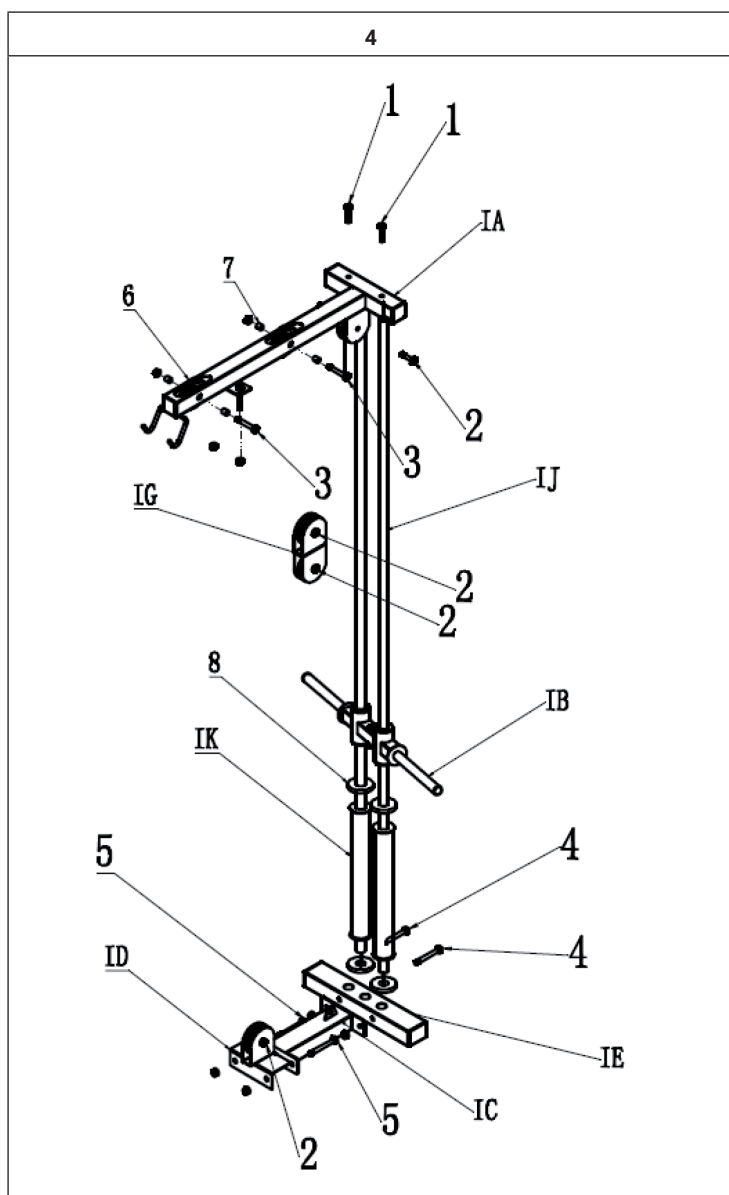



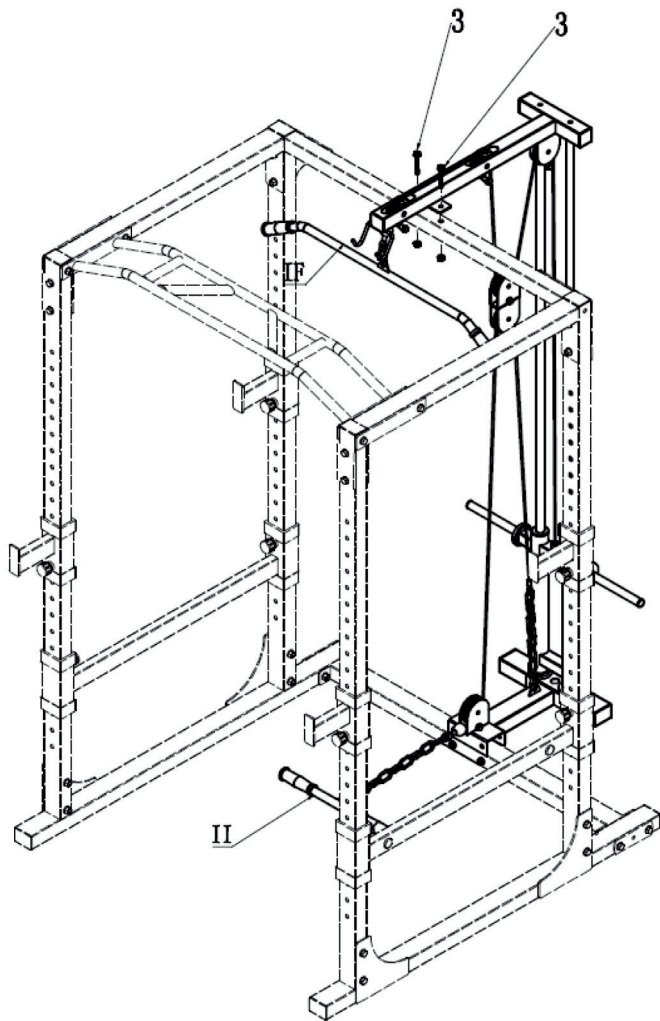



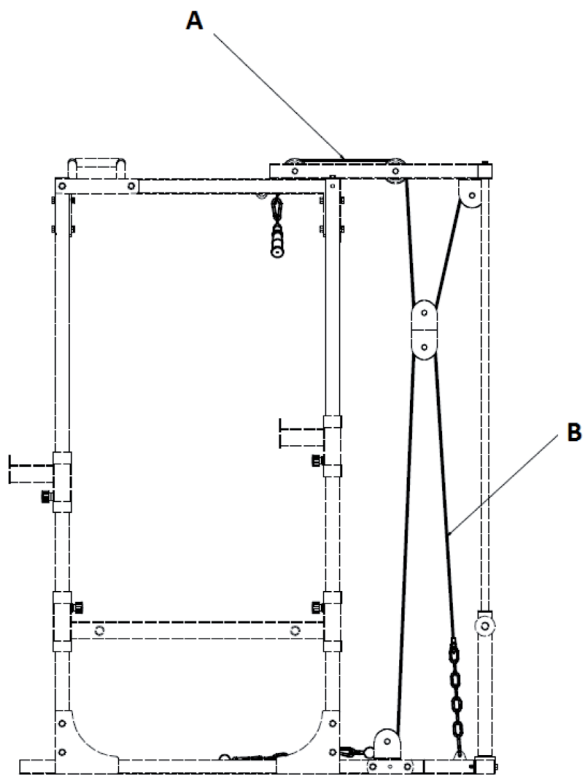
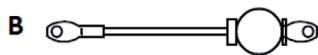
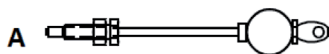



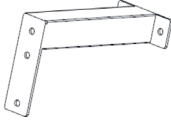
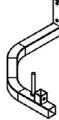

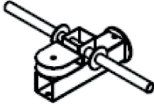



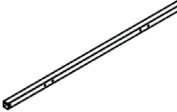



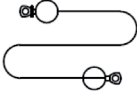







5



6



COMPOSANTS TIRAGE DE CÂBLE (SEULEMENT 10027846)

			
1 x2	2 x1	3 x1	4 x2
			
5 x4	6 x2	7 x2	8 x1
			
9 x1	10 x1	11 x8	12 x4
			
13 x2	M12 x 100 x4	M12 x 75 x8	M12 x 70 x4
			
M10 x 65 x6	M10 x 45 x8	M12 x24	M10 x14
			
M12 x12	M10 x6	M16 x4	M16 x4
			
25 x4	26 x12	27 x6	28 x4
			
29 x4	30 x2	31 x2	

MONTAGE DU TIRE-CÂBLE

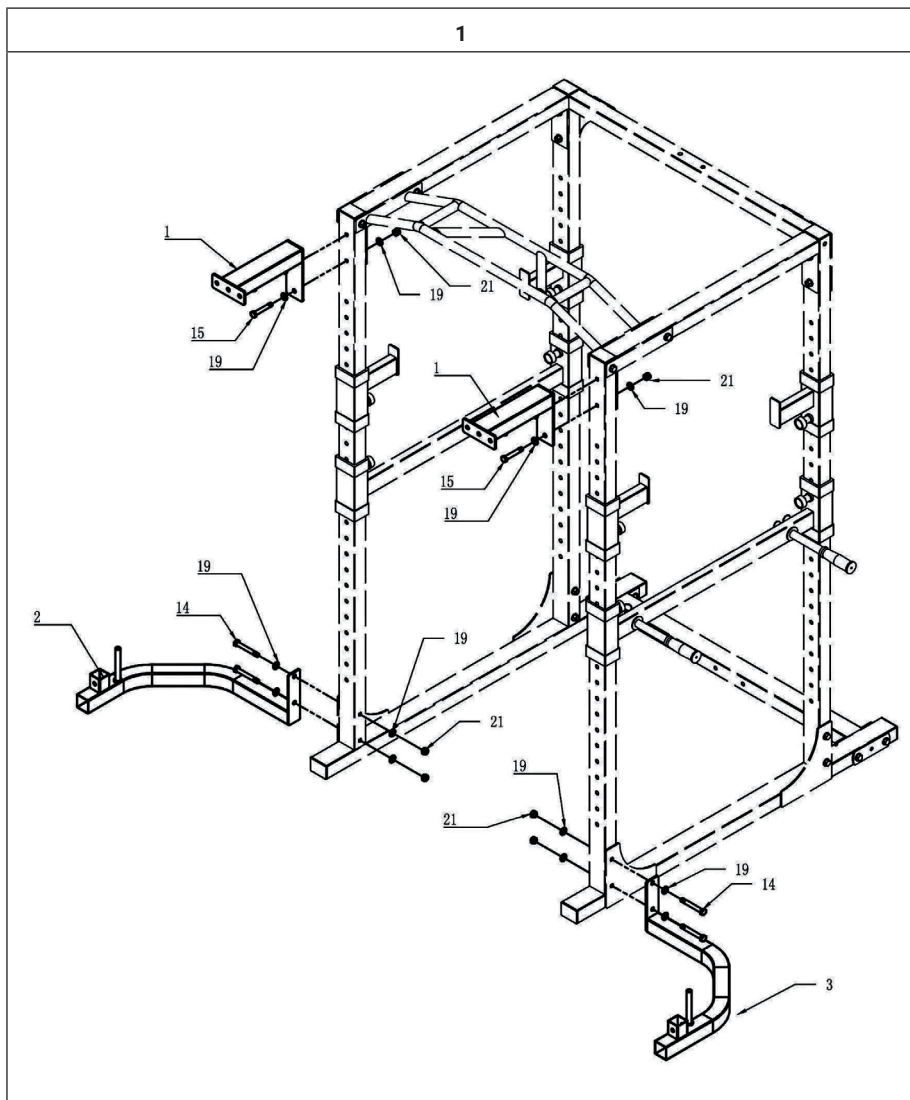

2

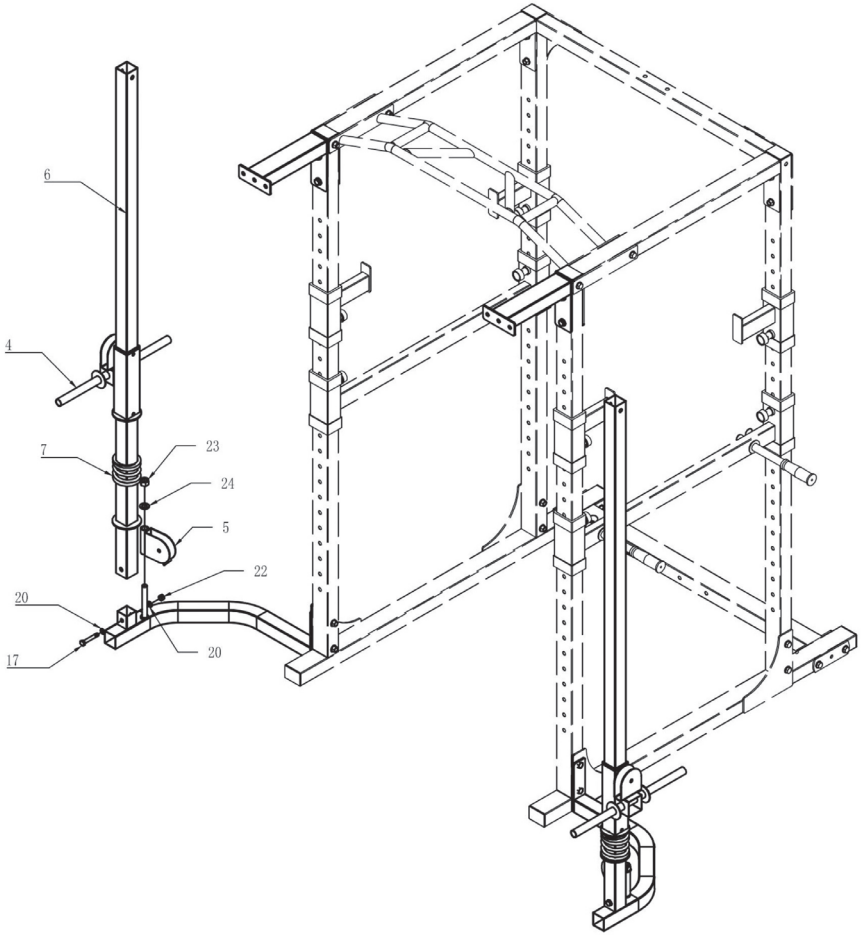

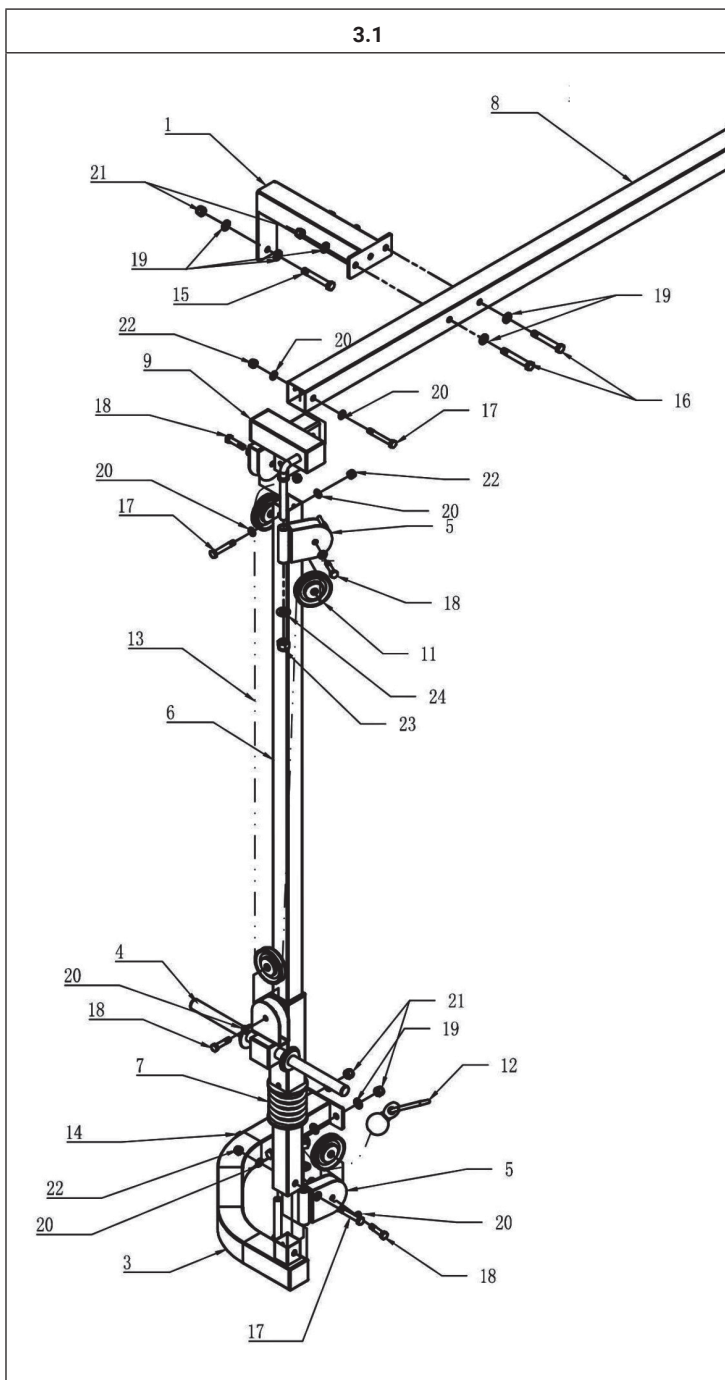

3.2

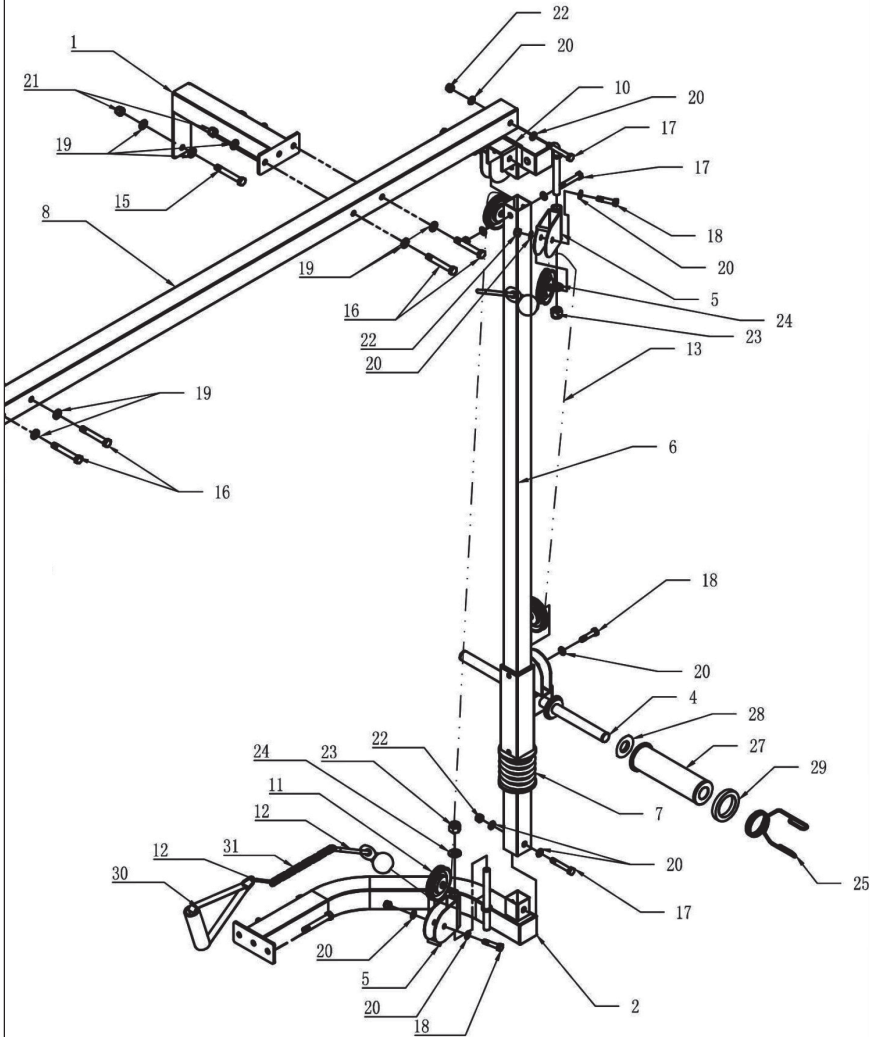

Gentile cliente,

la ringraziamo per l'acquisto del dispositivo. La preghiamo di leggere attentamente le seguenti istruzioni per l'uso e di seguirle per evitare possibili danni. Non ci assumiamo alcuna responsabilità per danni scaturiti da una mancata osservanza delle avvertenze di sicurezza e da un uso improprio del dispositivo. Scansionare il codice QR seguente per accedere al manuale d'uso più attuale e per ricevere informazioni sul prodotto.

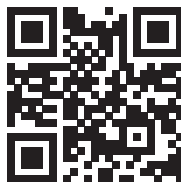

IMPORTANTI AVVERTENZE DI SICUREZZA

1. Leggere attentamente le istruzioni per l'uso prima di montare e utilizzare il dispositivo. L'uso sicuro ed efficace del dispositivo può essere ottenuto solo se il trampolino è montato, mantenuto e utilizzato correttamente. Assicurarsi che tutte le persone che utilizzano questo dispositivo siano a conoscenza delle avvertenze e delle istruzioni di sicurezza.
2. Se si stanno prendendo dei farmaci che influenzano la pressione sanguigna, la frequenza cardiaca o i livelli di colesterolo, si consiglia vivamente di consultare un medico prima di intraprendere l'allenamento.
3. Fare attenzione ai segnali del proprio corpo. Un allenamento errato o eccessivo può avere effetti negativi sulla salute. Smettere immediatamente l'allenamento se si sperimenta uno dei seguenti sintomi: dolore/senso di oppressione al torace, battito cardiaco irregolare, estrema mancanza di respiro, segni di stordimento, vertigini o nausea. Se si manifestano alcuni di questi sintomi, si consiglia di consultare un medico prima di continuare l'allenamento.
4. Questo dispositivo non è progettato per essere utilizzato da persone (inclusi bambini) con limitate facoltà fisiche, psichiche e sensoriali o carenza di esperienza e/o conoscenze, a meno che siano supervisionate da una persona responsabile del loro controllo o abbiano ricevuto istruzioni sull'utilizzo corretto e sicuro del dispositivo. Tenere sotto controllo i bambini per assicurarsi che non giochino con il dispositivo.
5. Prima di ogni sessione di allenamento, assicurarsi che tutte le viti e i fissaggi siano ben serrati.
6. La sicurezza del dispositivo può essere garantita solo se il trampolino viene regolarmente mantenuto e ispezionato per eventuali danni o segni di usura.

7. Utilizzare il dispositivo solo nel modo previsto. Se si scopre qualsiasi componente difettoso durante l'installazione o l'ispezione o se si notano rumori insoliti sul dispositivo durante l'allenamento, interrompere immediatamente gli esercizi. Non usare più il dispositivo finché il problema non è stato identificato e risolto.
8. Indossare un abbigliamento appropriato quando si usa il dispositivo. Evitare indumenti ampi, dato che potrebbero restare impigliati nel dispositivo e limitare la libertà di movimento.
9. Il dispositivo è stato testato e certificato secondo la norma EN 957 ed è approvato per uso domestico. Il peso massimo dell'utente non deve superare i 120 kg.
10. Il dispositivo non è adatto all'utilizzo terapeutico.

Piccoli oggetti/Componenti d'imballaggio

(sacchetti di plastica, cartone, ecc.)

Conservare i piccoli oggetti (ad es. viti e altro materiale di montaggio) e i componenti d'imballaggio fuori dalla portata dei bambini, in modo che non li ingeriscano. Non lasciare che i bambini giochino con la pellicola. Pericolo di soffocamento!

Utilizzo conforme

Questo dispositivo è utilizzato per l'allenamento fisico dei muscoli eseguendo pull-up ed esercizi simili. Il dispositivo è progettato e deve essere utilizzato esclusivamente per questo scopo. Può essere utilizzato solo secondo le modalità descritte in questo manuale.









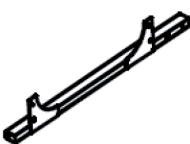
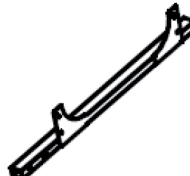
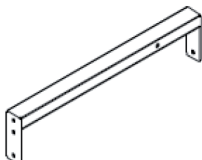
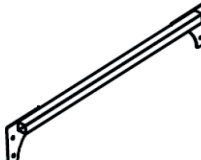
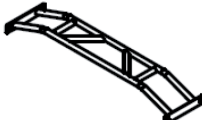

Trasporto del dispositivo

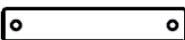
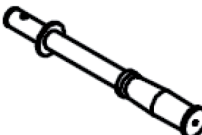
Si prega di conservare l'imballaggio originale. Per assicurare una protezione sufficiente durante il trasporto, mettere il dispositivo nell'imballaggio originale.

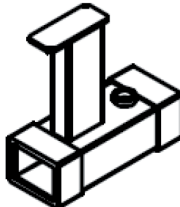









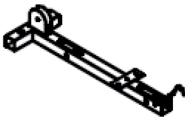

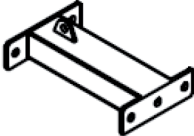

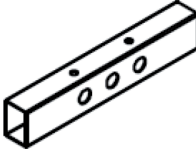

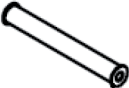

Pulizia della superficie esterna

Non utilizzare liquidi volatili, come spray per insetti. Se si esercita forza eccessiva durante la pulizia, è possibile che si rovini la superficie.

COMPONENTI DELL'UNITÀ PRINCIPALE

			
A 1x	B 1x	C 2x	D 1x
			
E 1x	F 1x	G 4x	H 2x
			
I 2x	J 1x	K 1x	L 4x
			
M 2x	1 8x Vite (M12x90), rondelle, dadi	2 8x Vite (M12x95), rondelle, dadi	3 8x Vite (M12x75), rondelle, dadi
			
4 2x Perno (8x40 mm)			
	R 8x Perno M20		

COMPONENTI TORRETTA LATISSIMUS (SOLO 10027847)

			
IA 1x	IB 1x	IC 1x	ID 1x
			
IE 1x	IF 1x	IG 1x	IH 2x
			
II 2x	IJ 2x	IK 2x	
			
Vite (M10x25), 1 rondella, dado 2x	Vite (M10x45), 2 rondelle, dadi 4x	Vite (M10x70), 3 rondelle, dadi 8x	Vite (M10x90), 4 rondelle, dadi 2x
			
Perrgo (8x40 mm) 2x	6 6x	7 4x	8 4x

MONTAGGIO

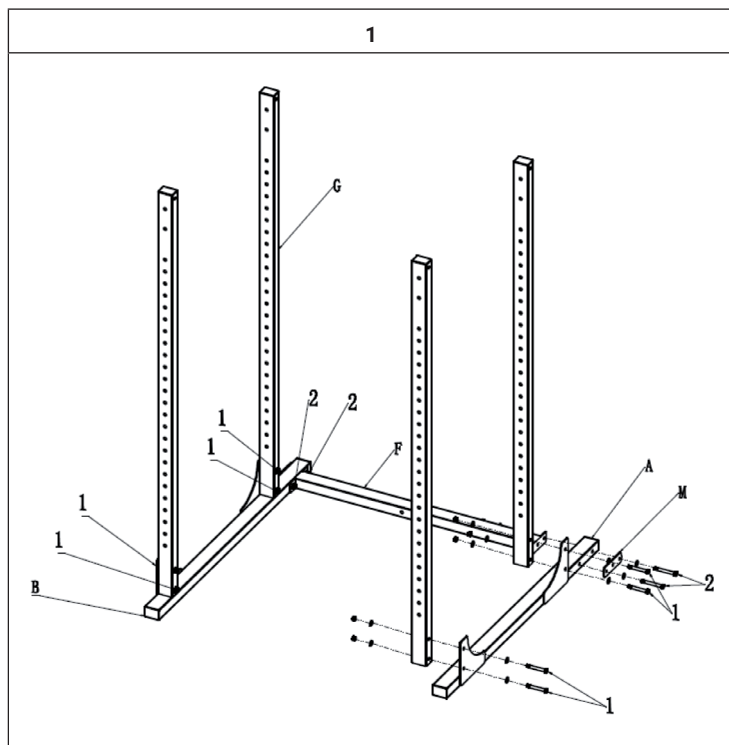

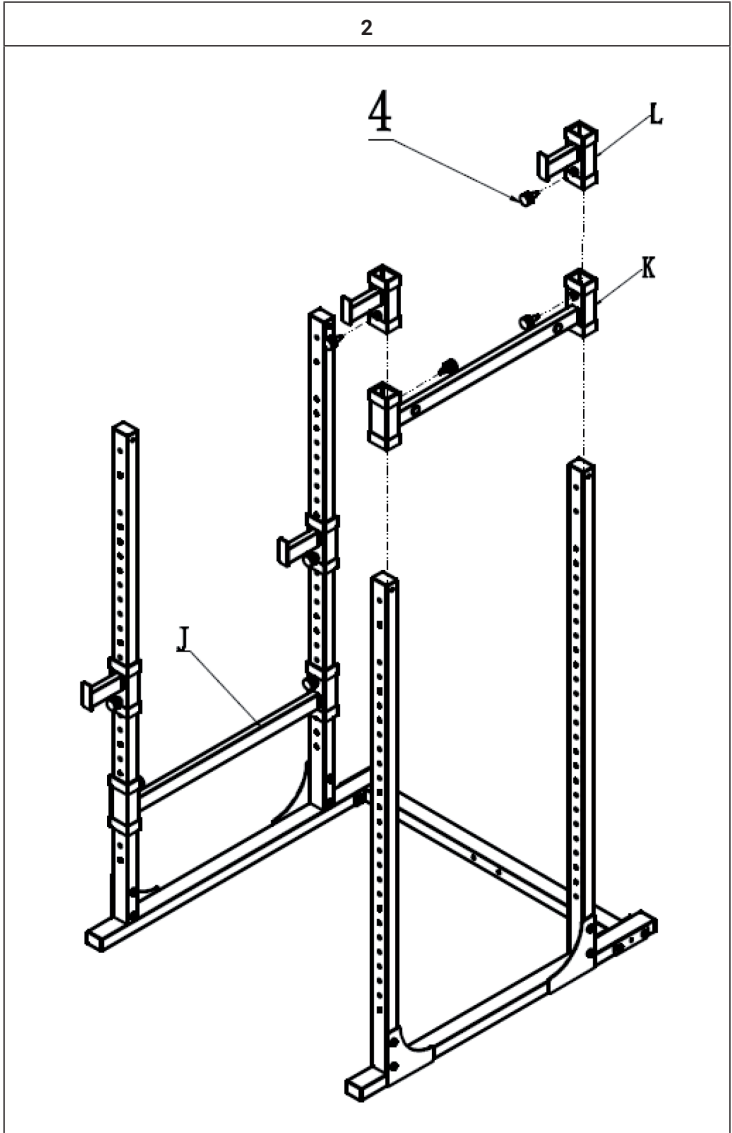

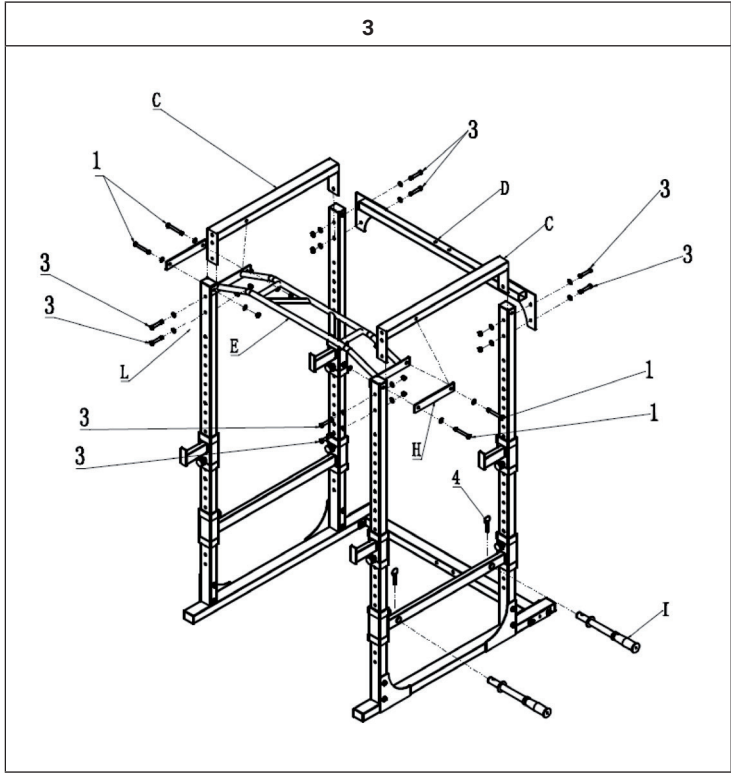

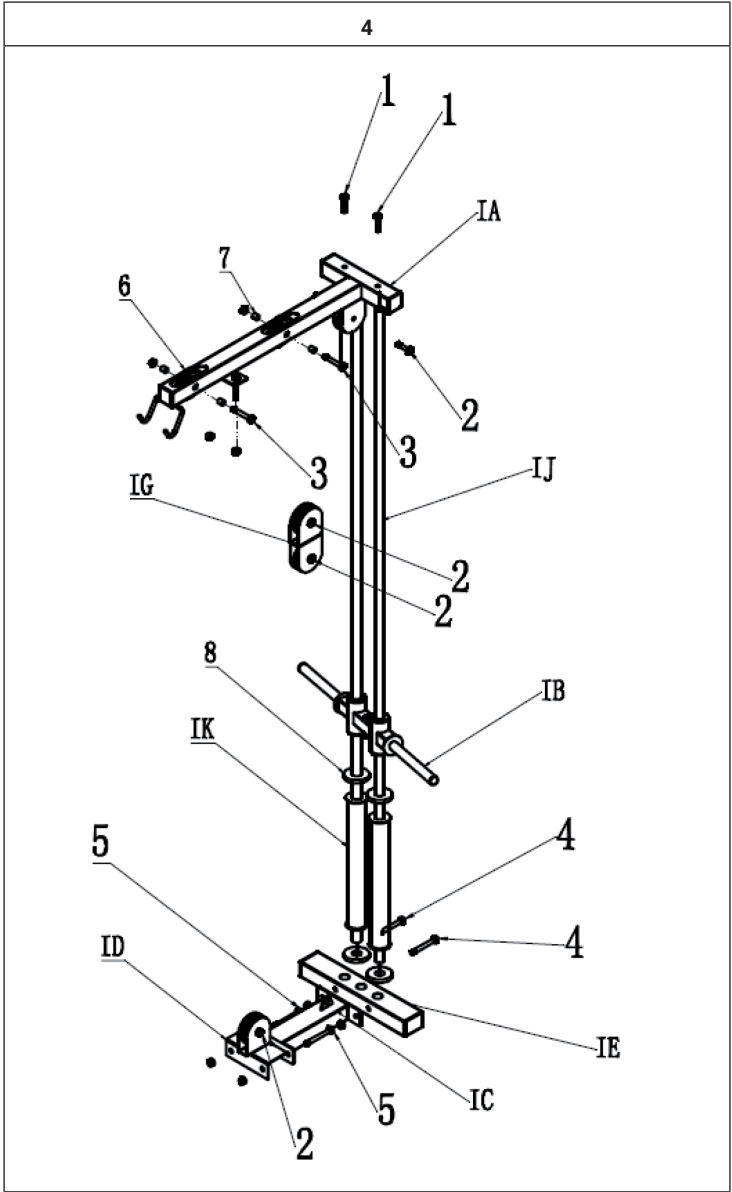



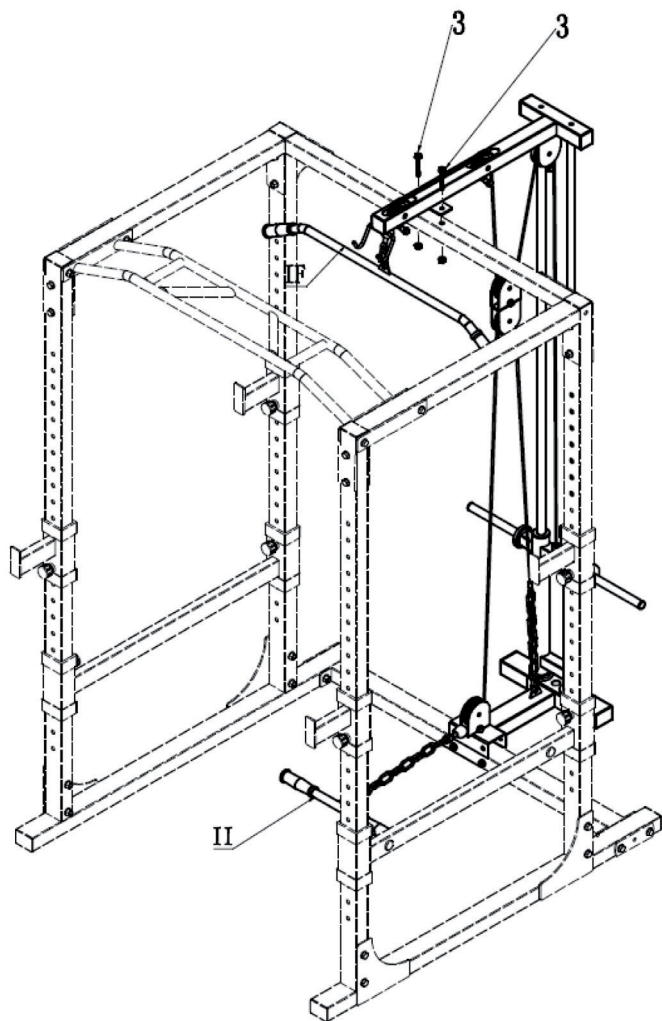



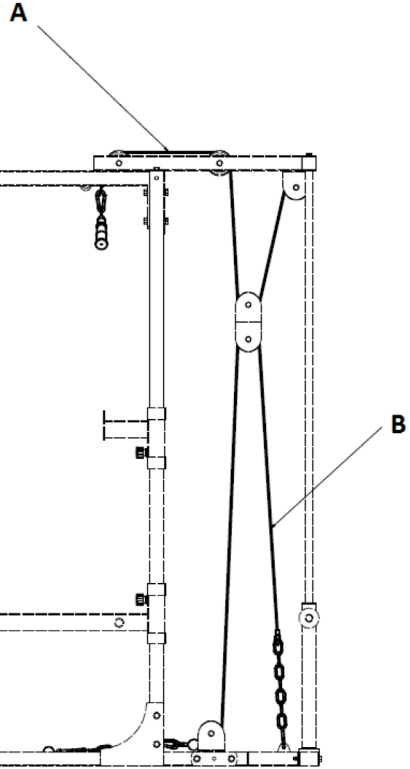
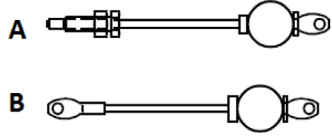



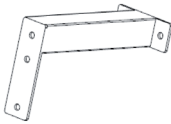
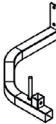

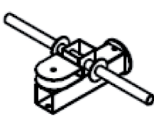



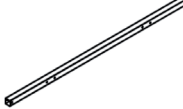



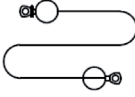







5



6



COMPONENTI PER L'ESTRAZIONE DEI CAVI (SOLO 10027846)

			
1 x2	2 x1	3 x1	4 x2
			
5 x4	6 x2	7 x2	8 x1
			
9 x1	10 x1	11 x8	12 x4
			
13 x2	M12 x 100 14 x4	M12 x 75 15 x8	M12 x 70 16 x4
			
M10 x 65 17 x6	M10 x 45 18 x8	M12 19 x24	M10 20 x14
			
M12 21 x12	M10 22 x6	M16 23 x4	M16 24 x4
			
25 x4	26 x12	27 x6	28 x4
			
29 x4	30 x2	31 x2	

MONTAGGIO DEL TIRACAVI

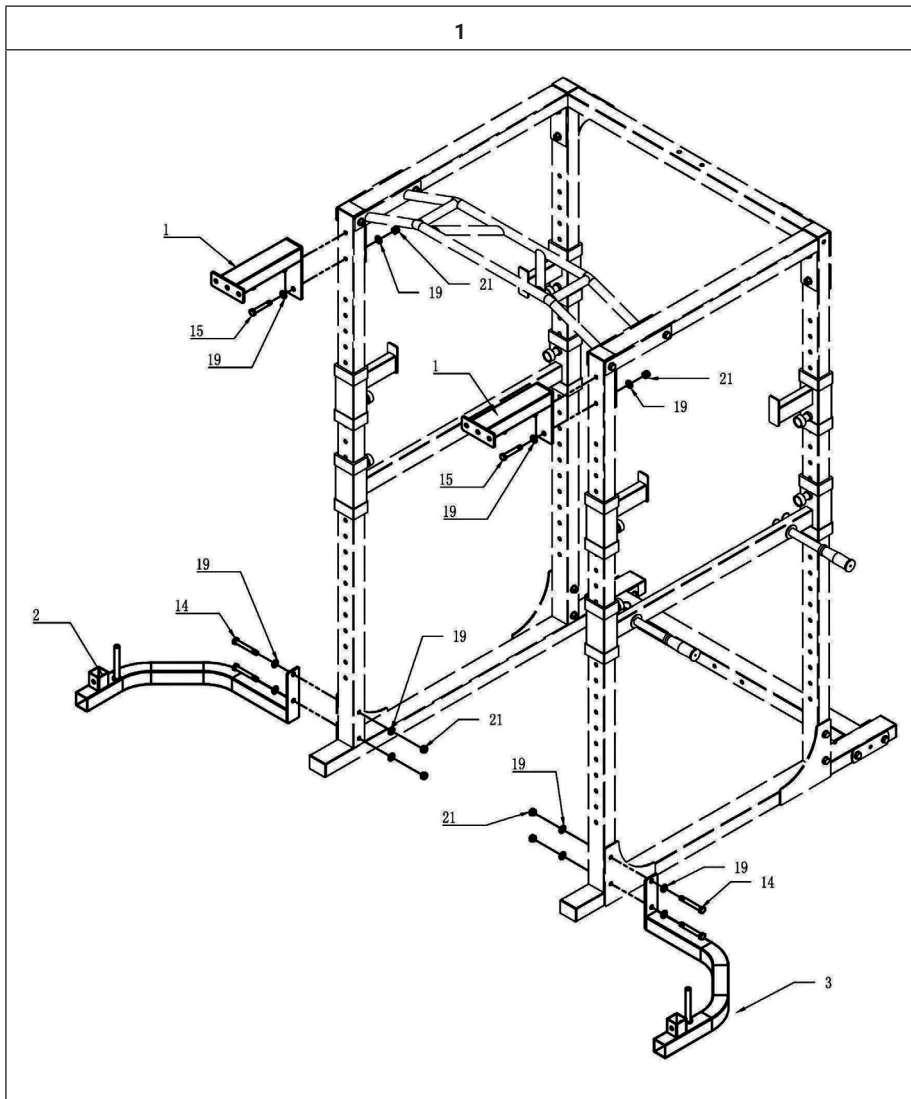

2

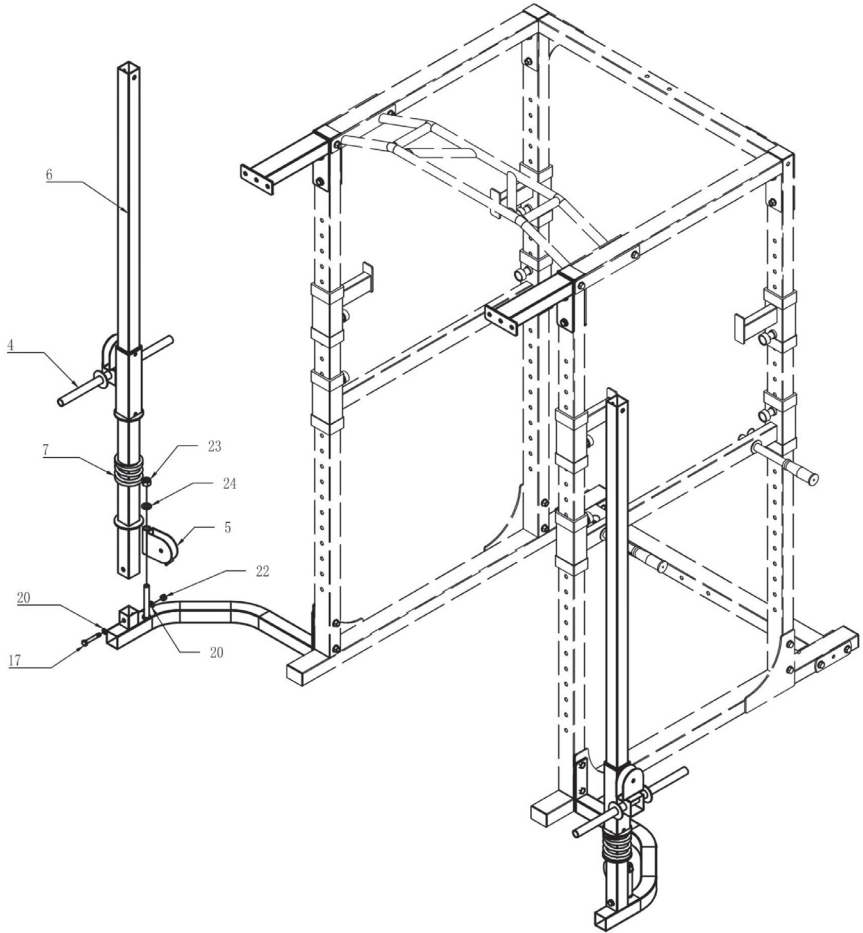

3.1

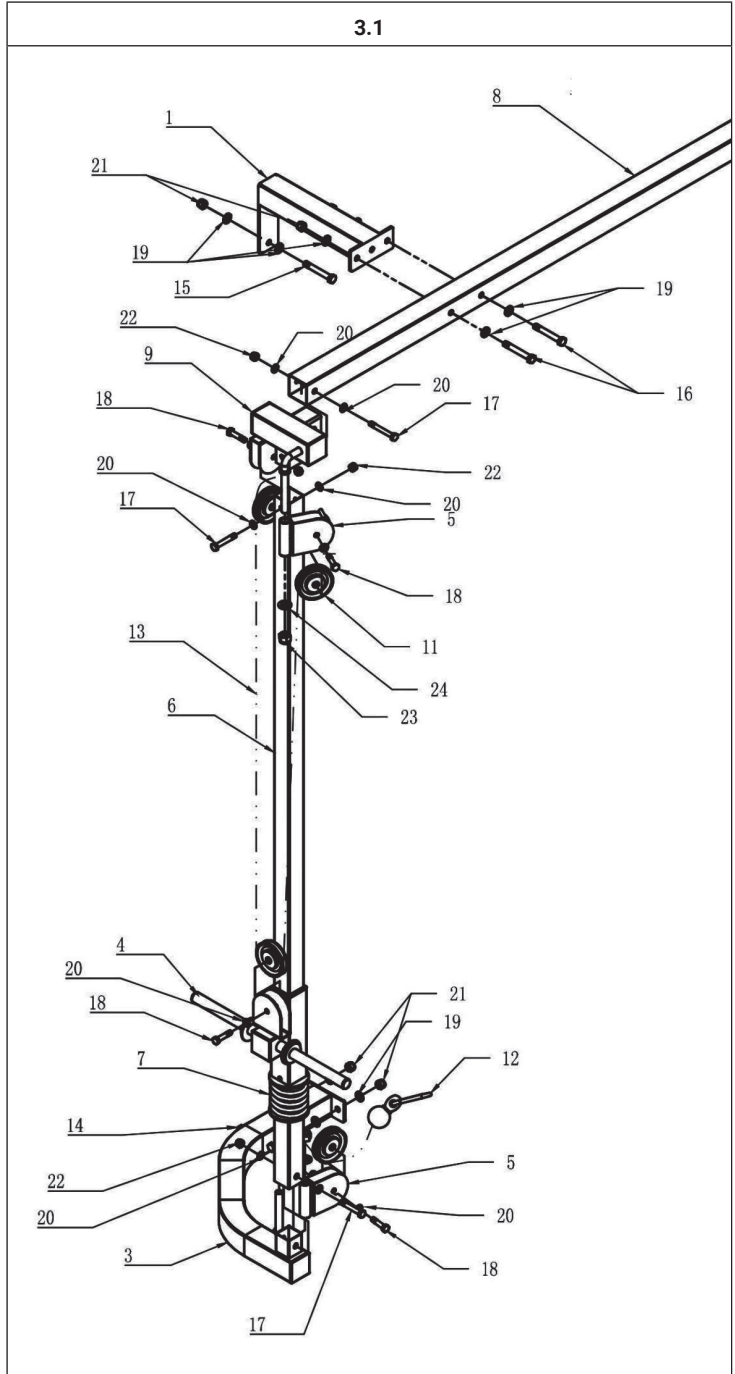

3.2

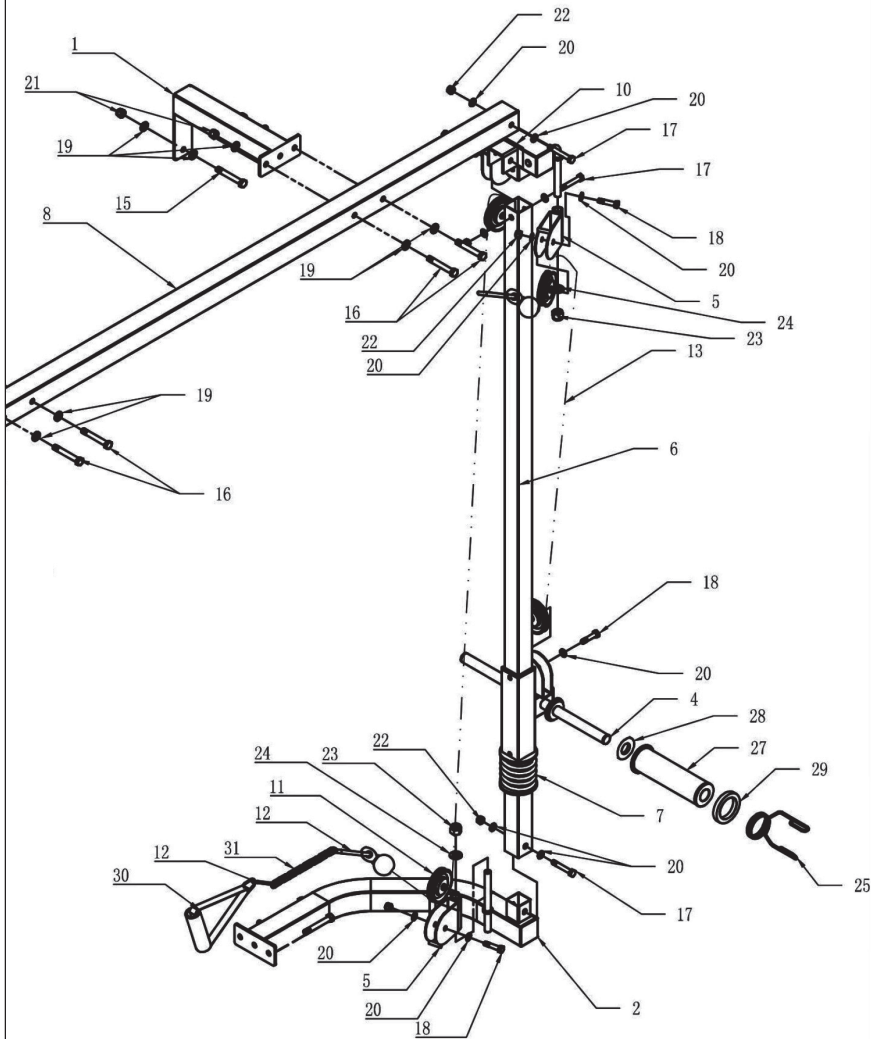

HERSTELLER

Manufacturer | Fabricante | Fabricant | Produttore

Chal-Tec GmbH, Wallstraße 16, 10179 Berlin, Deutschland (Germany).

IMPORTEUR FÜR GROSSBRITANNIEN

Importer for Great Britain | Importador para Gran Bretaña | Importateur pour la Grande Bretagne | Importatore per la Gran Bretagna

Berlin Brands Group UK Limited
PO Box 42
272 Kensington High Street
London, W8 6ND
United Kingdom

