

Nass-Trockensauger

10029182 10029183

KLARSTEIN

Sehr geehrter Kunde,

wir gratulieren Ihnen zum Erwerb Ihres Gerätes. Lesen Sie die folgenden Anschluss- und Anwendungshinweise sorgfältig durch und befolgen Sie diese, um möglichen technischen Schäden vorzubeugen. Für Schäden, die durch Missachtung der Sicherheitshinweise und unsachgemäßen Gebrauch entstehen, übernehmen wir keine Haftung.

Inhalt

Technische Daten	2
Lieferumfang	2
Sicherheitshinweise	3
Geräteübersicht.	5
Inbetriebnahme	6
Reinigung und Pflege	7
Fehlerbehebung	8
Hinweise zur Entsorgung	8
Konformitätserklärung	8

Technische Daten







Artikelnummer	10029182 10029183
Stromversorgung	220-240 V 50 Hz
Leistungsaufnahme	max. 2200 W (1000 W Geräteleistung, 1000 W Steckdose)
Lärmpegel	< 82 dB (A)









Lieferumfang

- Staubsauger x 1
- Flexibler Schlauch x 1
- Nassbürste x 1
- Verlängerungsrohr x 2
- Bürstenaufsatz x 1

Sicherheitshinweise

- Falls das Netzkabel beschädigt ist, muss es durch ein Originalkabel des Herstellers oder seinem Kundendienst ersetzt werden.
- Dieses Gerät ist nicht für die Verwendung durch Personen vorgesehen (Kinder eingeschlossen), die verminderte körperliche, sensorische oder geistige Fähigkeiten haben oder nicht über ausreichende Erfahrung und Kenntnisse verfügen; außer sie haben von einer Person, die für ihre Sicherheit verantwortlich ist, Anweisungen für den Gebrauch des Geräts erhalten oder werden von dieser beaufsichtigt.
- Kinder dürfen mit dem Gerät nicht spielen.
- Die Reinigung und Wartung darf nicht von unbeaufsichtigten Kindern erfolgen.
- Der Netzstecker muss aus der Steckdose gezogen werden, bevor das Gerät gereinigt oder gewartet wird.

⊘	Saugen Sie keine scharfkantigen oder heißen Materialien.	
⊘	Das Gerät darf nicht Hitze ausgesetzt werden.	
⊘	Ziehen Sie den Netzstecker, nachdem Sie das Gerät benutzt haben und vor jeder Reinigung. Ziehen Sie dabei am Stecker und nicht am Netzkabel.	
⊘	Stecken Sie keine Gegenstände in die Öffnungen. Verwenden Sie das Gerät nicht mit blockierten Öffnungen. Bewahren Sie das Gerät nicht in der Nähe von Staub, Flusen und Haaren auf.	
⊘	Verwenden Sie den Staubsauger nicht ohne einsetzten Staubbehälter oder Filter.	
⊘	Saugen Sie kein Mehl, Zement usw., um das Gerät nicht zu überfordern.	

	<p>Das Gerät sollte mit einem trockenen oder feuchten Tuch gereinigt werden. Es darf nicht in Wasser getaucht werden. Verwenden Sie zur Reinigung keine Lösungsmittel.</p>	
	<p>Das Gerät ist nur für Haushaltszwecke und nicht für den betrieblichen Einsatz bestimmt.</p>	
	<p>Vermeiden Sie die Berührung Ihrer Möbel mit der Düse oder dem Bürstenaufsatz.</p>	
	<p>Verwenden Sie das Netzkabel nicht, um das Gerät damit zu tragen.</p>	

Geräteübersicht

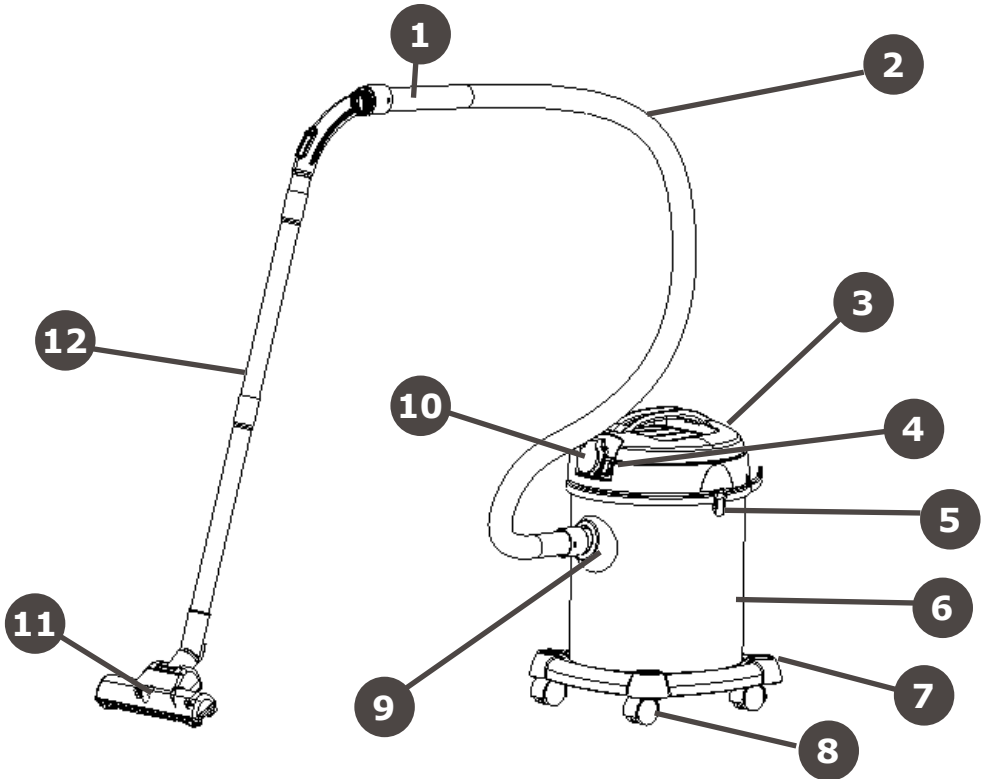

1 Handgriff

2 Schlauch

3 Deckel

4 Ein/Aus-Schalter

5 Haken

6 Staubbehälter

7 Basis

8 Rollen

9 Schlauchanschluss / Saugöffnung



10 Stromanschluss

11 Saugfuss

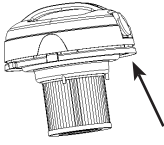
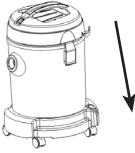
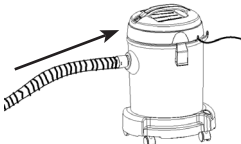
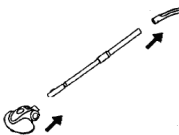
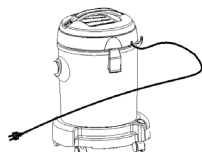

12 Rohr

Inbetriebnahme

Zusammensetzen

<p>Staubfilter:</p> <p>Setzen Sie den Filter vorsichtig in den Motorkopf ein.</p>	
<p>Staubbehälter:</p> <p>Setzen Sie den Staubbehälter in das Gerät ein.</p>	
<p>Flexibler Schlauch</p> <p>Stecken Sie das Ende des Schlauchs in die Saugöffnung. Achten Sie darauf, dass der Schlauch einklinkt.</p>	
<p>Aufsätze</p> <p>Wählen Sie die gewünschten Aufsätze (Bürste oder Düse) und befestigen Sie den jeweiligen Aufsatz am Rohr.</p>	
<p>Wickeln Sie das Netzkabel ab.</p>	
<p>Schließen Sie den Netzstecker an. Schalten Sie das Gerät ein.</p>	

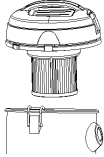
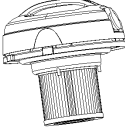
Reinigung und Pflege

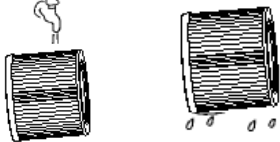
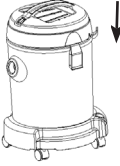
Öffnen Sie den Motorkopf.	
Entnehmen Sie den Staubfilter.	
Leeren Sie den Staubbehälter.	
Spülen Sie den Staubfilter mit Wasser. Trocknen Sie ihn anschließend.	
Setzen Sie das Gerät wieder zusammen.	

Fehlerbehebung

Problem	Mögliche Ursache	Lösung
Der Motor startet nicht.	Der Netzstecker sitzt nicht fest in der Steckdose. Die Steckdose ist beschädigt.	Stecken Sie den Stecker richtig in die Steckdose. Überprüfen Sie die Steckdose. Schalten Sie das Gerät ein.
Die Saugkraft lässt nach.	Das Gerät ist verstopft. Der Staubfilter muss gereinigt werden. Der Staubbehälter sitzt nicht fest. Der Filter ist blockiert.	Entfernen Sie die Verstopfung. Reinigen Sie den Staubfilter. Setzen Sie den Staubbehälter noch einmal richtig ein. Reinigen Sie den Filter.

Hinweise zur Entsorgung



Befindet sich die linke Abbildung (durchgestrichene Mülltonne auf Rädern) auf dem Produkt, gilt die Europäische Richtlinie 2002/96/EG. Diese Produkte dürfen nicht mit dem normalen Hausmüll entsorgt werden. Informieren Sie sich über die örtlichen Regelungen zur getrennten Sammlung elektrischer und elektronischer Gerätschaften. Richten Sie sich nach den örtlichen Regelungen und entsorgen Sie Altgeräte nicht über den Hausmüll. Durch die regelkonforme Entsorgung der Altgeräte werden Umwelt und die Gesundheit ihrer Mitmenschen vor möglichen negativen Konsequenzen geschützt. Materialrecycling hilft, den Verbrauch von Rohstoffen zu verringern.

Konformitätserklärung



Hersteller: Chal-Tec GmbH, Wallstraße 16, 10179 Berlin, Deutschland

Dieses Produkt entspricht den folgenden Europäischen Richtlinien:

2004/108/EG (EMV)
2006/95/EG (LVD)
2011/65/EU (RoHS)

Dear Customer,

Congratulations on purchasing this equipment. Please read this manual carefully and take care of the following hints on installation and use to avoid technical damages. Any failure caused by ignoring the mentioned items and cautions mentioned in the operation and installation instructions are not covered by our warranty and any liability.

Contents

Technical Data	9
Scope of Supply	9
Security Instructions.	10
Assembly.	12
Operation	13
Cleaning and maintenance.	14
Troubleshooting	15
Disposal Considerations	15
Declaration of Conformity	15

Technical Data







Item number	10029182 10029183
Power supply	220-240 V 50/60 Hz
Rated power	max. 2200 W (1200 W device, 1000 W socket)
Sound level	<82 dB (A)









Scope of Supply

- Vacuum cleaner x 1
- Flexible hose x 1
- Wet brush x 1
- Operating instructions x 1
- Extension tube x 2
- Assembled brush x 1

Security Instructions

- If the supply cord is damaged, it must be replaced by a special cord or assembly available from the manufacturer or its service agent .
- This appliance is not intended for use by persons(including children)with reduced physical, sensory or mental capabilities or lack of experience and knowledge, unless they have been given supervision or instruction concerning use of the appliance by a person responsible for their safety.
- Children should be supervised to ensure that they do not play with the appliance.
- .Cleaning and user maintenance shall not be made by children without supervision.
- The plug must be removed from the socket-outlet before cleaning or maintaining the appliance.

⊘	Do not vacuum any sharp-edged, hot or incandescent materials. .	
⊘	The appliance should not be exposed to heat.	
⊘	Unplug the appliance from the mains supply socket after use and before every cleaning. Pull the plug, not the mains cable, in order to disconnect the appliance from the mains.	
⊘	Do not put any object into openings. Do not use with any opening blocked. Keep free of dust, lint, hair etc.	
⊘	Do not use the vacuum cleaner without dust container or dust filter in place.	
⊘	Do not use the vacuum cleaner without dust container or dust filter in place	

	<p>Do not vacuum any flour, cement etc, in order to avoid the overloads.</p>	
	<p>This appliance is intended for domestic use only and not for commercial applications.</p>	
	<p>Avoid the nozzle or brush touching the surface of the furniture.</p>	
	<p>Do not use the mains wire to carry the appliance. Do not pull the mains wire over sharp edges.</p>	

Assembly

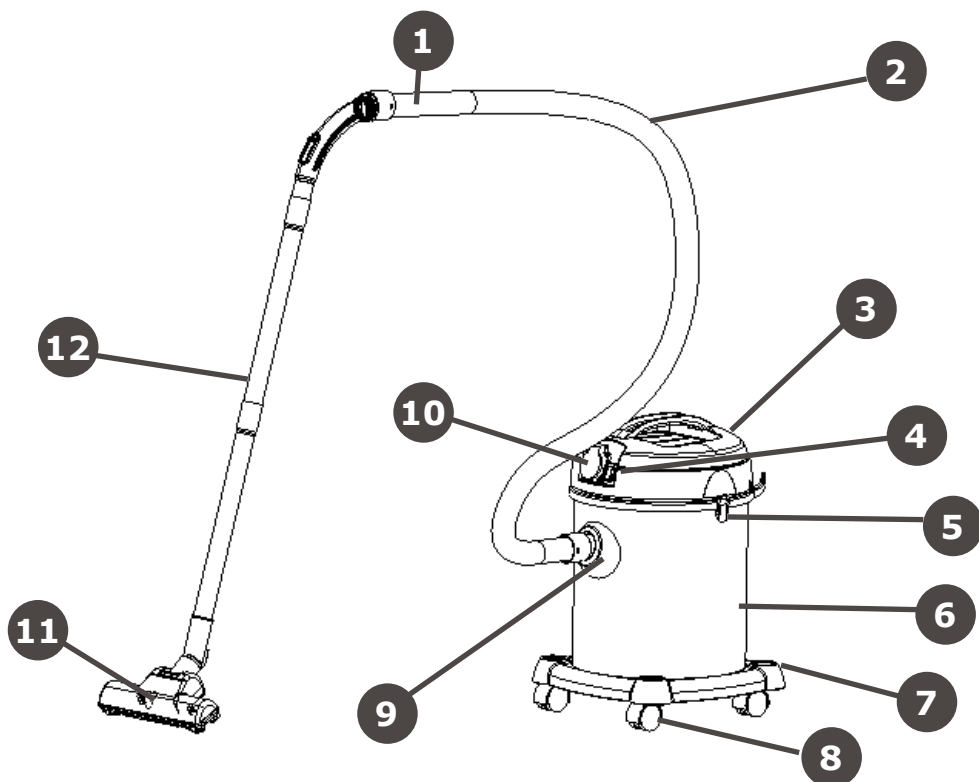

1 Hose handle

2 Hose

3 Cover

4 On/Off switch

5 Hook

6 Dust container

7 Base

8 Wheel

9 Inlet

10 Electrical outlet

11 Brush



12 Plastic tube

Operation

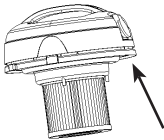
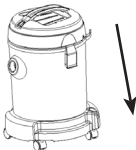
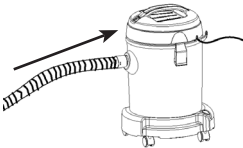
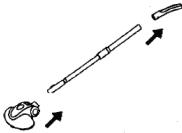
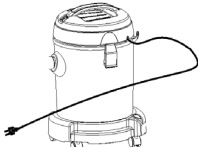
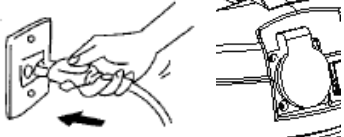
Assembly

<p>Dust filter</p> <p>Put the dust filter carefully in the machine head.</p>	 A line drawing of the machine head with a dust filter being inserted into its top. An arrow points to the filter.
<p>Dust container</p> <p>Attach the dust container to the hand vacuum cleaner.</p>	 A line drawing of the dust container being attached to the bottom of the machine head. An arrow points downwards.
<p>Flexible hose</p> <p>To use the flexible hose, insert the end of the hose into the suction hole. Make sure, that it is snapped in the positioning.</p>	 A line drawing of the dust container with a flexible hose being inserted into its side suction hole. An arrow points to the hose.
<p>Accessories</p> <p>Choose your desired accessory (brush or nozzle) and attach it to the suction hole.</p>	 A line drawing showing a brush or nozzle accessory being attached to the suction hole. An arrow points to the accessory.
<p>Unwind the power cord.</p>	 A line drawing of the machine with the power cord being unwound from its side. An arrow points to the cord.
<p>Plug the appliance and switch on. Rated power for electrical outlet.</p>	 A line drawing showing a hand plugging the power cord into an electrical outlet. An arrow points to the plug.

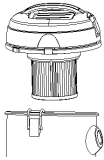
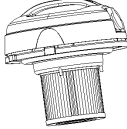
Cleaning and maintenance

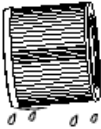
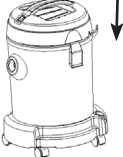
<p>Open the machine head.</p>	
<p>Take out the dust filter</p> <p>Empty the dust container.</p> <p>Wash off the dust filter with cleaning water. Dry up the dust filter.</p>	   
<p>Assemble the vacuum cleaner.</p>	

Troubleshooting

Problem	Possible reason	Advice
Motor does not start	-Power cord not firmly plugged into outlet. Outlet damaged Cleaner not switched on.	Plug unit firmly Check the Outlet Switch on the appliance
Suction power is weaker	Unit clogged Dust filter needs cleaning Dust container not in position. Filter blocked	Remove the blockage. Clean the dust filter. Attach the dust container again to the cleaner Clean the filter.

Disposal Considerations



According to the European waste regulation 2002/96/EC this symbol on the product or on its packaging indicates that this product may not be treated as household waste. Instead it should be taken to the appropriate collection point for the recycling of electrical and electronic equipment. By ensuring this product is disposed of correctly, you will help prevent potential negative consequences for the environment and human health, which could otherwise be caused by inappropriate waste handling of this product. For more detailed information about recycling of this product, please contact your local council or your household waste disposal service.

Declaration of Conformity



Producer: Chal-Tec GmbH, Wallstraße 16, 10179 Berlin.

This product is conform to the following European Directives:

2004/108/EC (EMC)
2011/65/EU (RoHS)
2006/95/EC (LVD)

Gentile cliente,

La ringraziamo per aver scelto il nostro prodotto. La preghiamo di leggere e di seguire attentamente le seguenti istruzioni in modo da evitare eventuali danni. Decliniamo ogni responsabilità in caso di danni dovuti ad una mancata osservanza delle norme di sicurezza e ad un uso improprio del prodotto.

Indice

Dati tecnici	16
Consegna	16
Avvertenze di sicurezza	17
Descrizione del prodotto	19
Messa in funzione	20
Pulizia e manutenzione	21
Ricerca e risoluzione degli errori.	22
Smaltimento	22
Dichiarazione di conformità	22

Dati tecnici















Numero articolo	10029182 10029183
Alimentazione	220-240 V 50 Hz
Potenza	max. 2200 W (1000 W attrezzatura, 1000 W presa)
Livello sonoro	< 82 dB (A)



Consegna

- Aspirapolvere x 1
- Tubo flessibile x 1
- Spazzola per lavare x 1
- Tubo estensibile x 2
- Accessori spazzola

Avvertenze di sicurezza

- Se il cavo di alimentazione è danneggiato, esso deve essere sostituito dal produttore con un cavo originale.
- Il dispositivo non è destinato a persone (bambini compresi) con ridotte capacità fisiche, sensoriali, mentali o che non dispongono dell'esperienza e della conoscenza necessarie, a meno che una persona responsabile della loro sicurezza illustri loro le avvertenze di sicurezza e come utilizzare il dispositivo.
- Non lasciare che i bambini giochino con il dispositivo.
- La pulizia e la manutenzione possono essere eseguite dai bambini solo se sorvegliati.
- Staccare sempre la spina dalla presa prima di ogni operazione di pulizia o di eseguire la manutenzione.

	<p>Non aspirare materiali caldi o appuntiti.</p>	
	<p>Non esporre il dispositivo al calore.</p>	
	<p>Staccare la spina dopo l'utilizzo e prima di ogni operazione di pulizia. Non tirare il cavo di alimentazione per staccare la spina.</p>	
	<p>Non infilare oggetti nelle aperture. Non utilizzare il dispositivo se le aperture sono ostruite. Non conservare il dispositivo vicino ad accumuli di polvere, lanugine, capelli ecc...</p>	
	<p>Non utilizzare l'aspirapolvere senza il contenitore raccogli-polvere o il filtro antipolvere al suo interno</p>	
	<p>Non aspirare farina, cemento, ecc. per non sovraccaricare il dispositivo.</p>	
	<p>Pulire il dispositivo con un panno asciutto o umido. Non immergere mai il dispositivo in acqua. Non utilizzare solventi.</p>	

⊘	Il dispositivo è destinato ad un uso domestico e non commerciale.	
⊘	Evitare il contatto dell'ugello o della spazzola aspirante con i mobili.	
⊘	Non spostare il dispositivo tirando il cavo di alimentazione.	

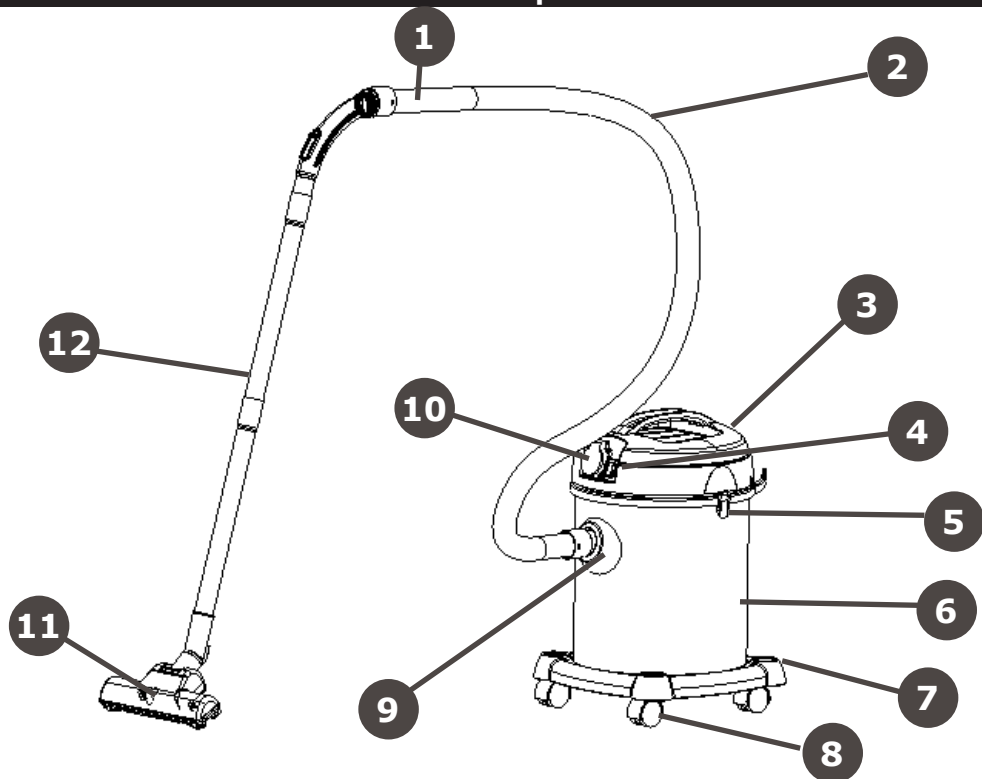

Descrizione del prodotto



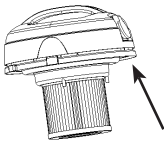
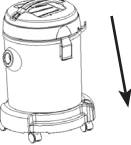
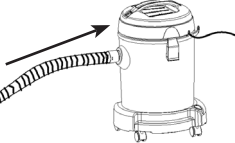
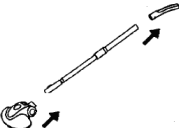

- | | |
|--------------------------------|---|
| 1 Impugnatura | 8 Rotelline |
| 2 Tubo flessibile | 9 Attacco tubo flessibile/apertura di aspirazione |
| 3 Coperchio | 10 Attacco corrente elettrica |
| 4 Interruttore ON/OFF | 11 Spazzola aspirante |
| 5 Gancio | 12 Tubo estensibile |
| 6 Contenitore raccogli-polvere | |
| 7 Base | |

Messa in funzion

Assemblaggio

<p>Filtro antipolvere:</p> <p>Inserire con cautela il filtro antipolvere nella testa motore.</p>	
<p>Contenitore raccogli-polvere:</p> <p>Inserire il contenitore raccogli-polvere nel dispositivo.</p>	
<p>Tubo flessibile</p> <p>Inserire l'estremità del tubo flessibile nell'apertura di aspirazione. Un clic segnala il corretto inserimento.</p>	
<p>Accessori</p> <p>Selezionare gli accessori desiderati (spazzola aspirante o ugello) e fissarli al tubo estensibile.</p>	
<p>Srotolare il cavo di rete.</p>	
<p>Inserire la spina nella presa. Accendere il dispositivo.</p>	

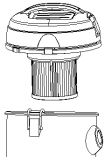
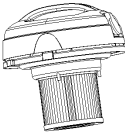
Pulizia e manutenzione

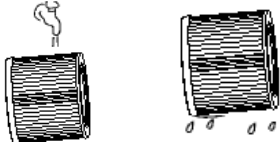
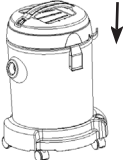
<p>Aprire la testa motore.</p>	
<p>Rimuovere il filtro antipolvere.</p>	
<p>Svuotare il contenitore raccogli-polvere.</p>	
<p>Lavare il filtro antipolvere con acqua. TInfine asciugare con cura.</p>	
<p>Assemblare di nuovo il dispositivo.</p>	

Ricerca e risoluzione degli errori

Problema	Causa possibile	Soluzione
Il dispositivo non si avvia	La spina non è inserita correttamente nella presa. La spina è danneggiata.	Inserire correttamente la spina nella presa. Controllare la presa. Accendere il dispositivo.
Il dispositivo non aspira correttamente.	Il dispositivo è ostruito. Il filtro antipolvere deve essere pulito. Il contenitore raccogliipolvere non è inserito correttamente. Il filtro antipolvere è ostruito.	Rimuovere ciò che ostruisce il dispositivo. Pulire il filtro antipolvere. Inserire il contenitore raccogliipolvere correttamente. Pulire il filtro antipolvere.

Smaltimento



Se sul prodotto è presente la figura a sinistra (il cassonetto dei rifiuti mobile sbarrato), si applica la direttiva europea 2002/96/CE. Questi prodotti non possono essere smaltiti con i rifiuti normali. Informarsi sulle disposizioni vigenti in merito alla raccolta separata di dispositivi elettrici ed elettronici. Non smaltire i vecchi dispositivi con i rifiuti domestici. Grazie al corretto smaltimento dei vecchi dispositivi, si proteggono il pianeta e la salute delle persone da possibili conseguenze negative. Il riciclo di materiali aiuta a ridurre il consumo di materie prime.

Dichiarazione di conformità



Produttore: Chal-Tec GmbH, Wallstraße 16, 10179 Berlino, Germania.

Questo prodotto è conforme alle seguenti direttive europee:

2004/108/CE (EMC)

2006/95/CE (LVD)

2011/65/UE (RoHS)

Chère cliente, cher client,

Toutes nos félicitations pour l'acquisition de ce nouvel appareil. Veuillez lire attentivement et respecter les instructions de ce mode d'emploi afin d'éviter d'éventuels dommages. Nous ne saurions être tenus pour responsables des dommages dus au non-respect des consignes et à la mauvaise utilisation de l'appareil.

Sommaire

Données techniques	23
Contenu de l'emballage	23
Consignes de sécurité	24
Aperçu de l'appareil	26
Fonctionnement	27
Nettoyage et entretien	28
Résolution des problèmes	29
Information sur le recyclage	29
Déclaration de conformité	29

Données techniques







Numéro d'article	10029182 10029183
Alimentation électrique	220-240 V 50 Hz
Puissance	max. 2200 W (1200 W appareil, 1000 W prise)
Niveau sonore	< 82 dB (A)









Contenu de l'emballage

- Aspirateur x 1
- Tuyau flexible x 1
- Brosse humide x 1
- Manche x 2
- Brosse

Consignes de sécurité

- Si le câble d'alimentation est endommagé, il doit être remplacé par un câble d'origine fourni par le fabricant ou le service client.
- Cet appareil ne doit pas être utilisé par des personnes (y compris les enfants) ayant des capacités physiques, sensorielles ou mentales réduites, ou ne disposant pas d'une expérience et de connaissances adéquates, sauf si elles sont sous la surveillance ou ont reçu les instructions d'utilisation appropriées d'une personne responsable de leur sécurité.
- Les enfants ne doivent pas jouer avec l'appareil.
- Le nettoyage et l'entretien ne doit pas être effectué par des enfants sans surveillance.
- Il faut retirer la fiche d'alimentation de la prise avant de nettoyer et d'entretenir l'appareil.

⊘	Ne pas aspirer d'objets coupants ou brûlants.	
⊘	L'appareil ne doit pas être exposé à la chaleur	
⊘	Débrancher la fiche d'alimentation après utilisation et avant tout nettoyage de l'appareil. Tirer sur la fiche et non sur le cordon d'alimentation.	
⊘	Ne pas boucher les ouvertures avec des objets. Ne pas utiliser l'appareil si les ouvertures sont bouchées. Ne pas entreposer l'appareil dans un endroit soumis à la poussière, à la saleté ou aux cheveux.	
⊘	Ne pas utiliser l'aspirateur sans réservoir ou filtre.	
⊘	Ne pas aspirer de farine, de ciment etc. pour ne pas surcharger l'appareil.	

	<p>Utiliser un chiffon sec ou humide pour nettoyer l'appareil. Ne pas plonger l'appareil dans l'eau. Ne pas utiliser de dissolvant pour le nettoyage.</p>	
	<p>L'appareil est conçu pour un usage domestique et non pour une utilisation professionnelle.</p>	
	<p>Éviter de toucher les meubles avec l'embout ou la brosse.</p>	
	<p>Ne pas se servir du câble d'alimentation pour porter l'appareil.</p>	

Aperçu de l'appareil

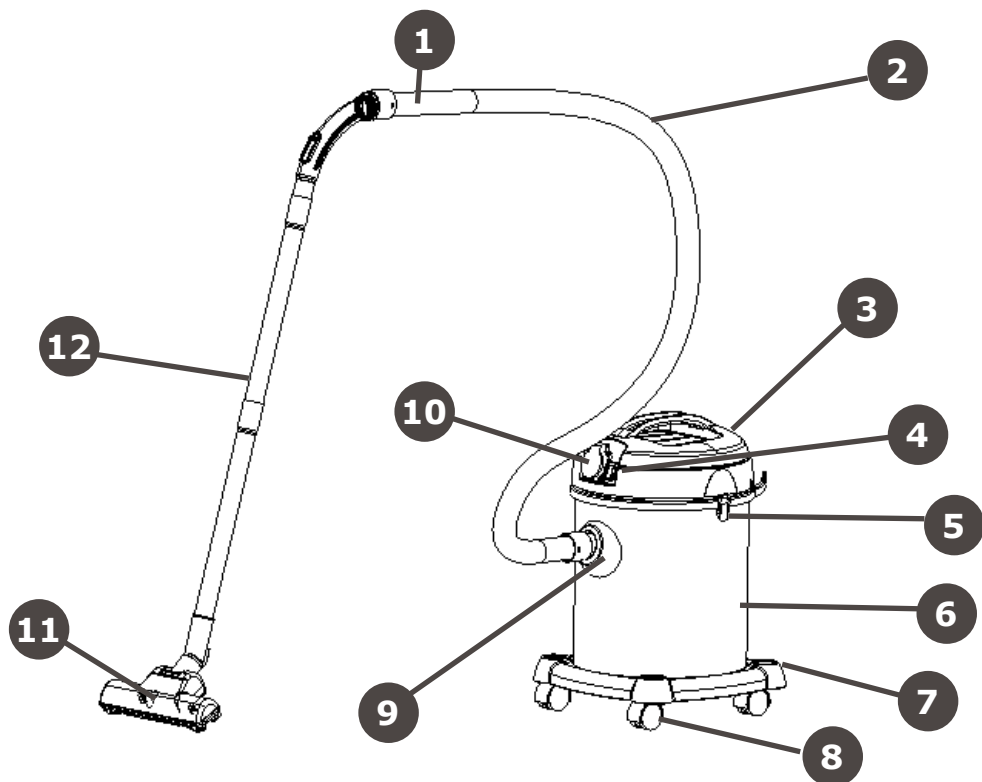

1 Poignée

2 Tuyau

3 Couvercle

4 Interrupteur marche/arrêt

5 Crochet

6 Réservoir

7 Socle

8 Roulettes

9 Raccord / ouverture d'aspirateur

10 Connecteur d'alimentation

11 Brosse



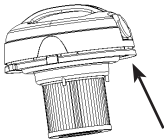
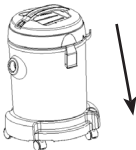
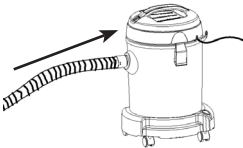
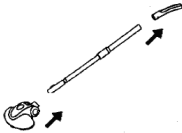
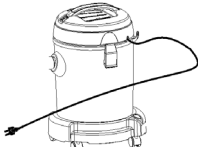
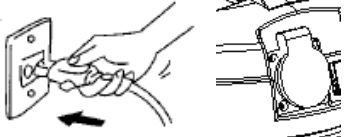

12 Manche

Fonctionnement

Fonctionnement

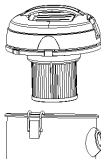
<p>Filtre à poussière :</p> <p>Placer le filtre dans la tête du moteur.</p>	
<p>Réservoir :</p> <p>Installer le réservoir dans l'appareil.</p>	
<p>Tuyau flexible</p> <p>Introduire le bout du tuyau dans l'ouverture de l'aspirateur. Veiller à ce que le tuyau s'enclenche bien.</p>	
<p>Embouts</p> <p>Sélectionner l'embout souhaité (brosse ou buse) et le fixer au manche.</p>	
<p>Dérouler le câble d'alimentation.</p>	
<p>Brancher la fiche d'alimentation. Mettre l'appareil en marche.</p>	

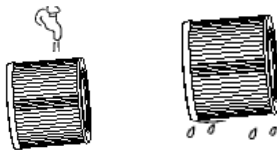
Nettoyage et entretien

Ouvrir la tête du moteur.	
Retirer le filtre à poussière.	
Vider le réservoir.	
Rincer le filtre à l'eau. Puis le sécher.	
Réassembler l'appareil.	

Résolution des problèmes

Problème	Cause possible	Solution
Le moteur ne fonctionne pas.	La fiche d'alimentation n'est pas bien enfoncée dans la prise électrique. La prise électrique est endommagée.	Enfoncer correctement la fiche dans la prise. Vérifier l'état de la prise. Mettre l'appareil en marche.
La force d'aspiration faiblit.	L'appareil est encombré. Le filtre à poussière doit être nettoyé. Le réservoir n'est pas correctement fixé. Le filtre est bloqué.	Désencombrer l'appareil. Nettoyer le filtre. Fixer correctement le réservoir. Nettoyer le filtre.

Information sur le recyclage



Vous trouverez sur le produit l'image ci-contre (une poubelle sur roues, barrée d'une croix), ce qui indique que le produit se trouve soumis à la directive européenne 2002/96/CE. Renseignez-vous sur les dispositions en vigueur dans votre région concernant la collecte séparée des appareils électriques et électroniques. Respectez-les et ne jetez pas les appareils usagés avec les ordures ménagères. La mise en rebut correcte du produit usagé permet de préserver l'environnement et la santé. Le recyclage des matériaux contribue à la préservation des ressources naturelles.

Déclaration de conformité



Fabricant : Chal-Tec GmbH, Wallstraße 16, 10179 Berlin, Allemagne.

Ce produit est conforme aux directives européennes suivantes :

2004/108/CE (CEM)

2006/95/CE (LVD)

2011/65/UE (RoHS)

Estimado cliente:

Le felicitamos por la adquisición de este producto. Lea atentamente el siguiente manual y siga cuidadosamente las instrucciones de uso con el fin de evitar posibles daños. La empresa no se responsabiliza de los daños causados por un uso indebido del producto o por haber desatendido las indicaciones de seguridad.

Índice

Datos técnicos	30
Contenido del envío	30
Indicaciones de seguridad	31
Descripción del aparato.	33
Puesta en marcha	34
Limpieza y cuidado	35
Detección y resolución de problemas	36
Indicaciones para la retirada del aparato	36
Declaración de conformidad.	36

Datos técnicos







Número de artículo	10029182 10029183
Suministro eléctrico	220-240 V 50 Hz
Consumo	max. 2200 W (1200 W aparato, 1000 W enchufe)
Nivel de ruido	< 82 dB (A)









Contenido del envío

- Aspiradora x1
- Tubo flexible x1
- Cepillo para limpieza en húmedo x1
- Manual de instrucciones x1
- Tubo extensible x2
- Cepillo x1

Indicaciones de seguridad

- Si el cable de alimentación está dañado, deberá ser sustituido por el fabricante o por el servicio de atención al cliente.
- Este aparato no está concebido para personas (niños incluidos) con discapacidades físicas, psíquicas o sensoriales o carentes de los conocimientos y experiencia necesarios, salvo que hayan sido previamente instruidos sobre las funciones del aparato y conozcan las indicaciones de seguridad.
- Los niños no deben jugar con el aparato.
- Los niños solamente podrán realizar labores de mantenimiento y limpieza bajo supervisión.
- Desconecte el aparato de la red eléctrica antes de limpiarlo o de realizar labores de mantenimiento.

⊘	No aspire materiales con cantos afilados ni a altas temperaturas..	
⊘	No exponga el aparato al calor.	
⊘	Desconecte el aparato cuando haya terminado de utilizarlo y antes de limpiarlo. Para ello, tire del cuerpo del enchufe y no del cable de alimentación.	
⊘	No introduzca ningún objeto en las ranuras. No utilice la aspiradora con las ranuras obstruidas. No almacene la aspiradora en lugares con polvo, pelusas o pelo.	
⊘	No utilice la aspiradora sin el filtro ni depósito.	
⊘	No aspire harina, cemento o materiales similares para no utilizar el aparato por encima de su rendimiento.	

	<p>Limpie el aparato con un paño seco o mojado. No lo sumerja en agua. No utilice productos químicos para limpiarlo.</p>	
	<p>El aparato está concebido solamente para uso doméstico, no para uso comercial.</p>	
	<p>Evite que los muebles entren con contacto con la boquilla de la aspiradora o con el cepillo.</p>	
	<p>No utilice el cable de alimentación para tirar del aparato.</p>	

Descripción del aparato

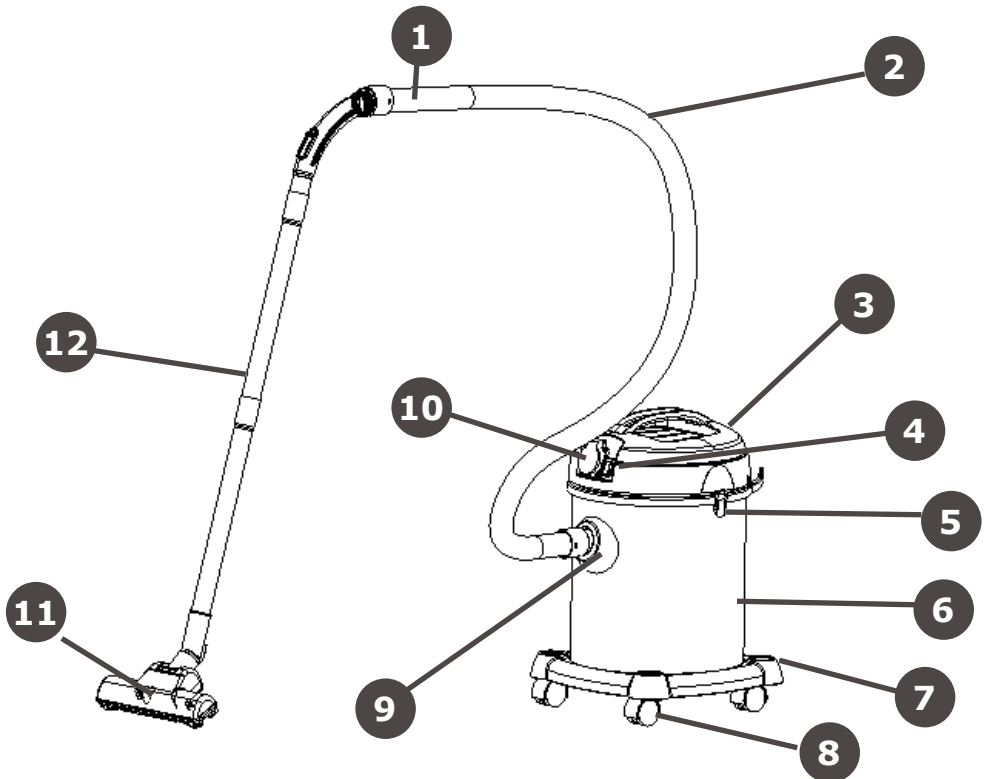

1 Asa

2 Tubo flexible

3 Tapa

4 Interruptor on/off

5 Gancho

6 Depósito para el polvo

7 Base

8 Ruedas

9 Conexión del tubo / orificio de succión



10 Conexión a la red eléctrica

11 Cepillo

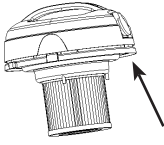
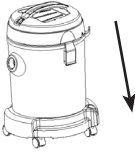
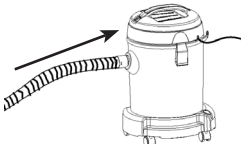
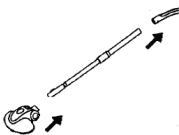
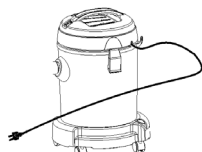

12 Tubo plástico

Puesta en marcha

Montaje

<p>Filtro:</p> <p>Introduzca el filtro con cuidado en la cabeza del motor.</p>	
<p>Depósito para el polvo:</p> <p>Introduzca el depósito dentro de la aspiradora.</p>	
<p>Tubo flexible</p> <p>Encaje un extremo del tubo en el orificio de succión. Asegúrese de que el tubo queda bien colocado.</p>	
<p>Accesorios</p> <p>Seleccione el accesorio deseado (cepillo o boquilla) y fíjelo al otro extremo del tubo.</p>	
<p>Desenrolle el cable de alimentación.</p>	
<p>Conecte el enchufe a la toma de corriente. Encienda la aspiradora.</p>	

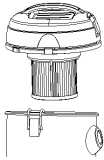
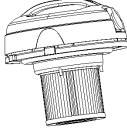
Limpieza y cuidado

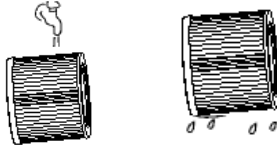
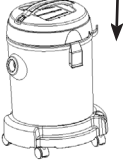
Abra la cabeza del motor.	
Retire el filtro.	
Vacíe el depósito para el polvo.	
Lave el filtro con agua y séquelo completamente.	
Vuelva a montar la aspiradora.	

DetECCIÓN Y RESOLUCIÓN DE PROBLEMAS

w	Posible causa	Solución
El motor no arranca.	El enchufe no está conectado correctamente a la toma de corriente. Toma de corriente averiada. La aspiradora no está encendida.	Conecte el enchufe correctamente a la toma de corriente. Compruebe la toma de corriente. Encienda la aspiradora.
La potencia de succión ha disminuido.	El aparato está obstruido. Es necesario limpiar el filtro. El depósito para el polvo no está bien colocado. El filtro está bloqueado.	Retire la obstrucción. Limpie el filtro. Coloque correctamente el depósito para el polvo. Limpie el filtro.

INDICACIONES PARA LA RETIRADA DEL APARATO



Si el aparato lleva adherida la ilustración de la izquierda (el contenedor de basura tachado) entonces rige la normativa europea, directiva 2002/96/CE. Este producto no debe arrojarse a un contenedor de basura común. Infórmese sobre las leyes territoriales que regulan la recogida separada de aparatos eléctricos y electrónicos. Respete las leyes territoriales y no arroje aparatos viejos al cubo de la basura doméstica. Una retirada de aparatos conforme a las leyes contribuye a proteger el medio ambiente y a las personas a su alrededor frente a posibles consecuencias perjudiciales para la salud. El reciclaje ayuda a reducir el consumo de materias primas.

DECLARACIÓN DE CONFORMIDAD



Fabricante: Chal-Tec GmbH, Wallstraße 16, 10179, Berlín (Alemania).

Este producto cumple con las siguientes directivas europeas:

2004/108/CE (EMC)

2011/65/UE (refundición RoHS 2)

2006/95/CE (baja tensión)