



blumfeldt

## Springbreak 2000

Getränkewagen  
Beverage Cart  
Carro de bebidas  
Chariot à boissons  
Carrello delle bevande

10029647





**Sehr geehrter Kunde,**

wir gratulieren Ihnen zum Erwerb Ihres Gerätes. Lesen Sie die folgenden Hinweise sorgfältig durch und befolgen Sie diese, um möglichen Schäden vorzubeugen. Für Schäden, die durch Missachtung der Hinweise und unsachgemäßen Gebrauch entstehen, übernehmen wir keine Haftung. Scannen Sie den folgenden QR-Code, um Zugriff auf die aktuellste Bedienungsanleitung und weitere Informationen rund um das Produkt zu erhalten:



---

**INHALTSVERZEICHNIS**

---

Einzelteile 4  
Zusammenbau 5

**English 7**  
**Français 11**  
**Español 15**  
**Italiano 19**

---

**HERSTELLER & IMPORTEUR (UK)**

---

**Hersteller:**

Chal-Tec GmbH, Wallstraße 16, 10179 Berlin, Deutschland.

**Importeur für Großbritannien:**

Berlin Brands Group UK Limited  
PO Box 42  
272 Kensington High Street  
London, W8 6ND  
United Kingdom

## EINZELTEILE

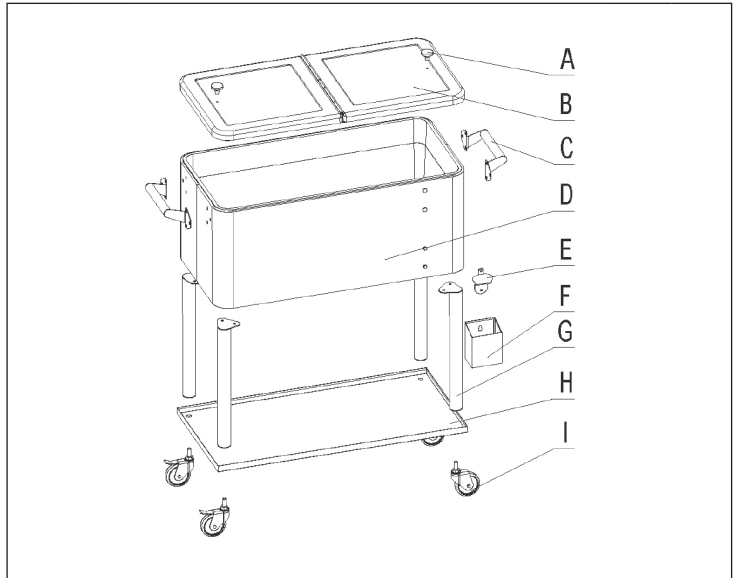

Nr.	Bezeichnung	Stk.
A	Deckelgriff	2
B	Deckel	1
C	Wagengriff	2
D	Getränkekasten	1
E	Flaschenöffner	1
F	Behälter für Flaschendeckel	1
G	Bein	4
H	Bodenregal	1
I	Räder (2 mit und 2 ohne Bremse)	4
AA	M6x16 Sechskantschraube	8
BB	M6x16 Innensechskant	14
CC	M6x16 Passschraube	2
DD	M5x35 Schraube	2

## ZUSAMMENBAU

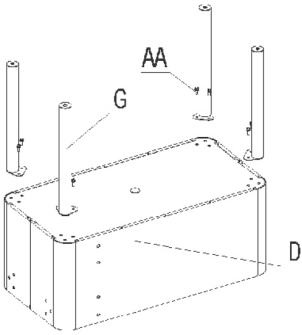
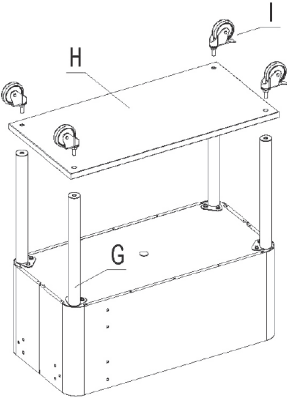
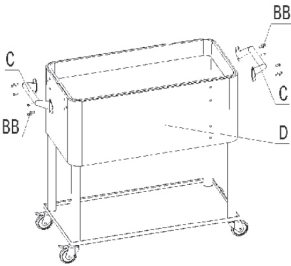
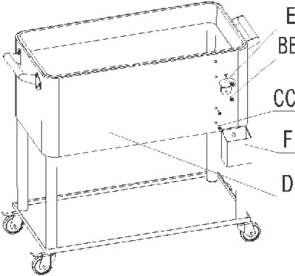
1	2
	
<p>Schrauben Sie die 4 Beine (G) an den Kasten. Verwenden Sie die Sechskantschrauben (AA).</p>	<p>Schrauben Sie die 4 Beine (G) an den Kasten. Setzen Sie die Rollen an die Löcher. Ziehen Sie die Schrauben jetzt noch nicht ganz fest.</p>
3	4
	
<p>Schrauben Sie die beiden Griffe (C) mit den Innensechskantschrauben (BB) an den Kasten (D). Ziehen Sie die Schrauben ganz fest.</p>	<p>Schrauben Sie den Flaschenöffner (E) mit den Innensechskantschrauben (BB) am Kasten (D) fest. Setzen Sie den Behälter für die Flaschendeckel an und montieren Sie ihn mit den Schrauben (DD).</p>

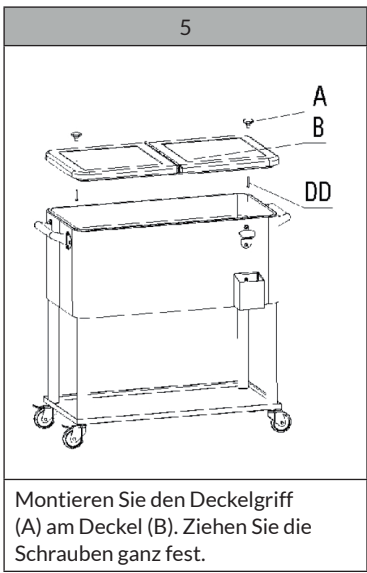

**Dear customer,**

Congratulations on the purchase of your appliance. Please read the following instructions carefully and follow them to prevent potential damage. We accept no liability for damage caused by disregarding the instructions or improper use. Please scan the QR code to access the latest operating instructions and for further information about the product.



---

**CONTENTS**

---

Individual parts 8

Assembly 9

---

**MANUFACTURER & IMPORTER (UK)**

---

**Manufacturer:**

Chal-Tec GmbH, Wallstraße 16, 10179 Berlin, Germany.

**Importer for Great Britain:**

Berlin Brands Group UK Limited

PO Box 42

272 Kensington High Street

London, W8 6ND

United Kingdom

## INDIVIDUAL PARTS

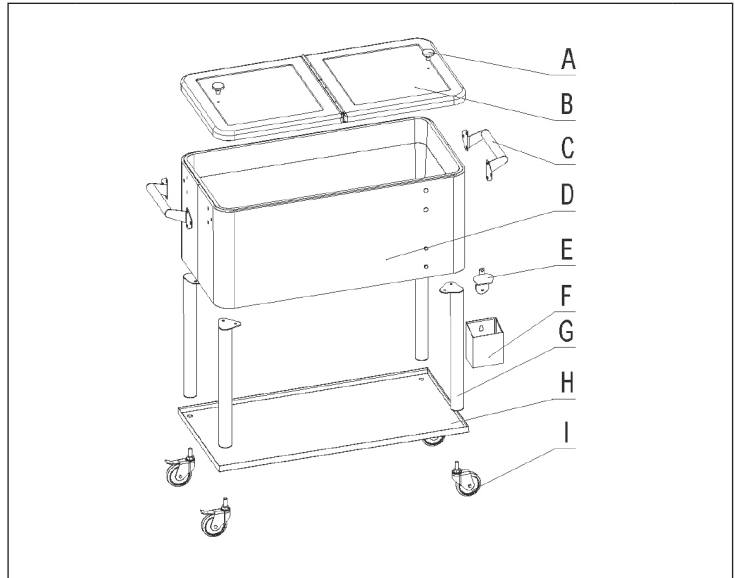

No.	Designation	Pc.
A	Lid handle	2
B	Cover	1
C	Wagon handle	2
D	Drinks crate	1
E	Bottle opener	1
F	Container for bottle tops	1
G	Leg	4
H	Floor shelf	1
I	Wheels (2 with and 2 without brake)	4
AA	M6x16 hexagon head screw	8
BB	M6x16 hexagon socket	14
CC	M6x16 fitting screw	2
DD	M5x35 screw	2

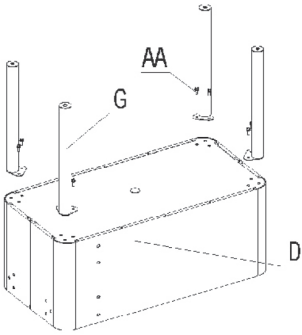
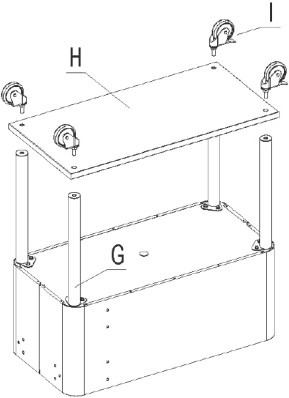
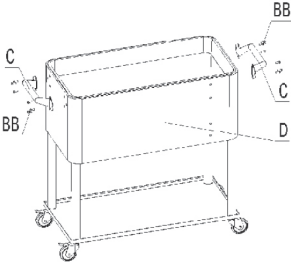
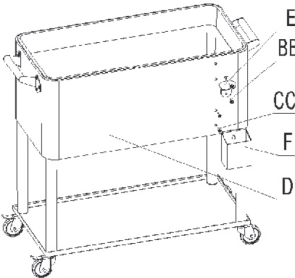

## ASSEMBLY

1	2
	
<p>Screw the 4 legs (G) to the box. Use the hexagon head screws (AA).</p>	<p>Screw the 4 legs (G) to the box. Place the rollers on the holes. Do not fully tighten the screws yet.</p>
3	4
	
<p>Screw the two handles (C) to the box (D) with the hexagon socket screws (BB). Tighten the screws well.</p>	<p>Screw the bottle opener (E) to the box (D) with the hexagon socket screws (BB). Put the bottle cap container in place and mount it with the screws (DD).</p>

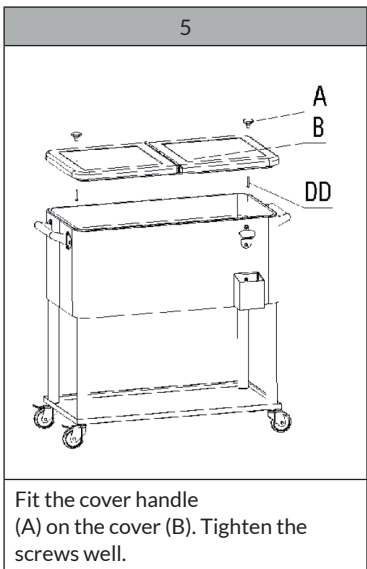

**Cher client, chère cliente,**

Toutes nos félicitations pour l'acquisition de ce nouvel appareil. Lisez attentivement les indications suivantes et suivez-les pour éviter d'éventuels dommages. Nous ne saurions être tenus pour responsables des dommages dus au non-respect des consignes et à la mauvaise utilisation de l'appareil. Scannez le QR-Code pour obtenir la dernière version du mode d'emploi ainsi que d'autres informations concernant le produit :



---

**SOMMAIRE**

---

Pièces détachées 12

Assemblage 13

---

**FABRICANT ET IMPORTATEUR (GB)**

---

**Fabricant :**

Chal-Tec GmbH, Wallstraße 16, 10179 Berlin, Allemagne.

**Importateur pour la Grande Bretagne :**

Berlin Brands Group UK Limited

PO Box 42

272 Kensington High Street

London, W8 6ND

United Kingdom

## PIÈCES DÉTACHÉES

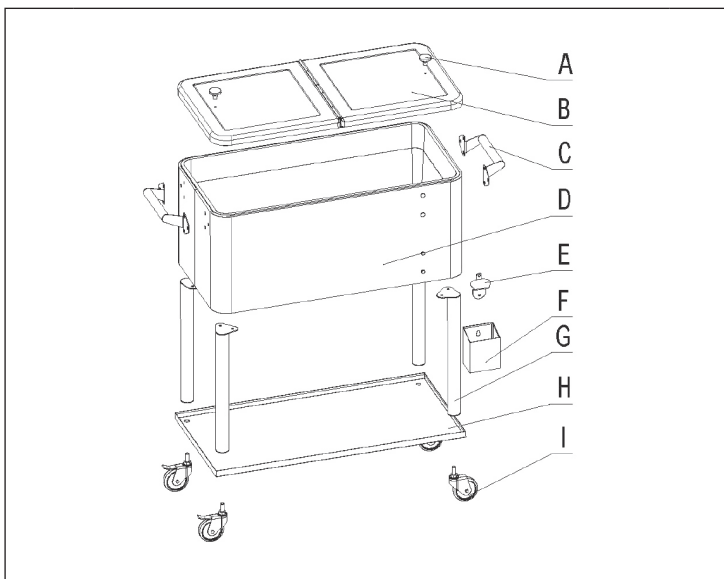

N°	Description	Qté
A	Poignée de couvercle	2
B	Couvercle	1
C	Poignée de chariot	2
D	Caisse à boissons	1
E	Ouvre-bouteille	1
F	Récipient à capsules	1
G	Pieds	4
H	Étagère de fond	1
I	Roues (2 avec et 2 sans frein)	4
AA	Vis hexagonale M6x16	8
BB	M6x16 Allen	14
CC	Vis d'ajustement M6x16	2
DD	Vis M5x35	2

# ASSEMBLAGE

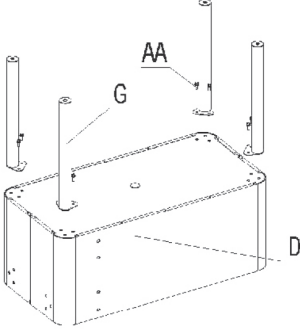
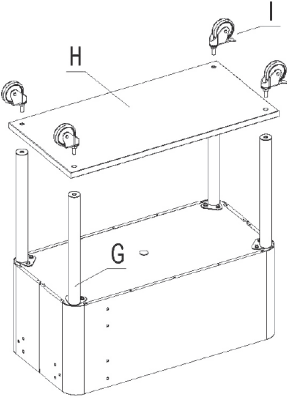
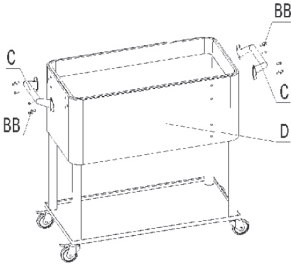
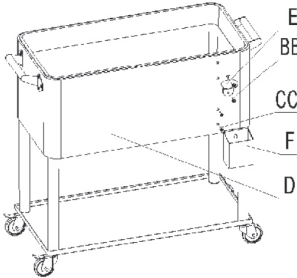
1	2
	
<p>Vissez les 4 pieds (G) sur le caisson. Utilisez les vis à tête hexagonale (AA).</p>	<p>Vissez les 4 pieds (G) sur le caisson. Placez les roues sur les trous. Ne serrez pas encore les vis à fond.</p>
3	4
	
<p>Vissez les deux poignées (C) sur le caisson (D) à l'aide des vis à six pans creux (BB). Serrez complètement les vis.</p>	<p>Vissez l'ouvre-bouteille (E) sur la caisse (D) à l'aide des vis à six pans creux (BB). Placez le récipient pour les capsules de bouteilles et montez-le avec les vis (DD).</p>

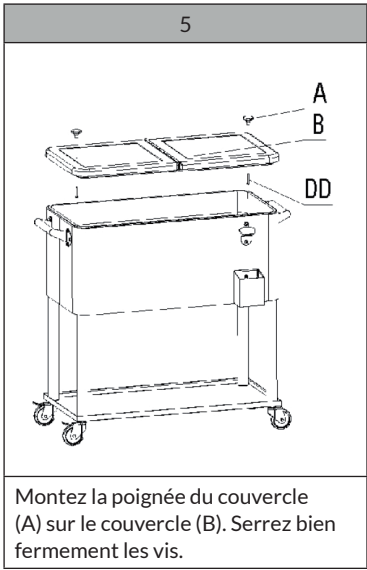

**Estimado cliente:**

Le felicitamos por la adquisición de este producto. Lea atentamente el siguiente manual y siga cuidadosamente las instrucciones de uso con el fin de evitar posibles daños. La empresa no se responsabiliza de los daños ocasionados por un uso indebido del producto o por haber desatendido las indicaciones de seguridad. Escanee el siguiente código QR para obtener acceso al manual de usuario más reciente y otra información sobre el producto.



---

## ÍNDICE

---

Componentes 16

Montaje 17

---

## FABRICANTE E IMPORTADOR (REINO UNIDO)

---

**Fabricante:**

Chal-Tec GmbH, Wallstraße 16, 10179 Berlín, Alemania.

**Importador para el Reino Unido:**

Berlin Brands Group UK Limited  
PO Box 42  
272 Kensington High Street  
London, W8 6ND  
United Kingdom

## COMPONENTES

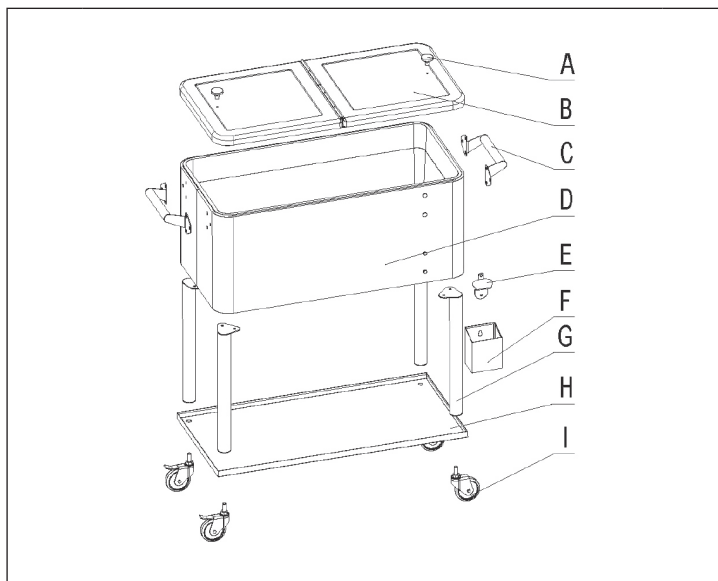

Núm.	Descripción	Uds.
A	Asa de la tapa	2
B	Tapa	1
C	Asa del carro	2
D	Caja de bebidas	1
E	Abridor de botellas	1
F	Recipiente para tapas de botellas	1
G	Pata	4
H	Estantería inferior	1
I	Ruedas (2 con y 2 sin freno)	4
AA	Tornillo de cabeza hexagonal M6x16	8
BB	Tornillo de cabeza hexagonal interna M6x16	14
CC	Tornillo de ajuste M6x16	2
DD	Tornillo M5x35	2

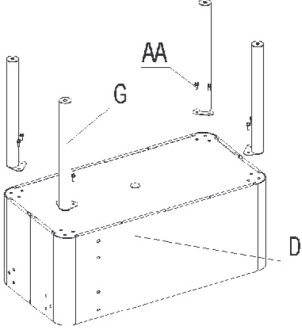
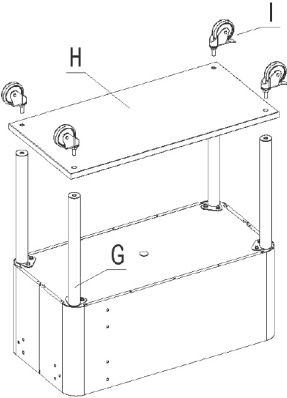
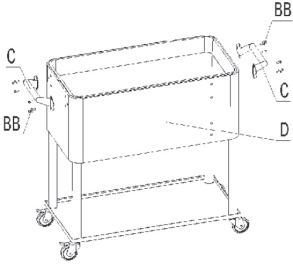
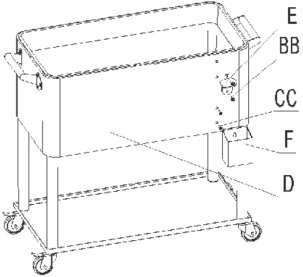

# MONTAJE

1	2
	
<p>Atornille las 4 patas (G) a la caja. Utilice los tornillos de cabeza hexagonal (AA).</p>	<p>Atornille las 4 patas (G) a la caja. Coloque las ruedas en los orificios. Apriete los tornillos, pero no hasta el final.</p>
3	4
	
<p>Atornille las dos asas (C) a la caja (D) con los tornillos de cabeza hexagonal interna (BB). Apriete bien los tornillos.</p>	<p>Atornille el abridor de botellas (E) a la caja (D) con los tornillos de cabeza hexagonal interna (BB). Coloque y atornille el recipiente para tapas de botellas con los tornillos (DD).</p>

5

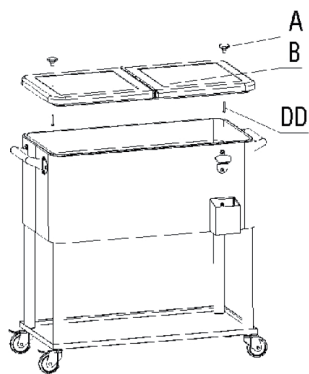

Monte el asa de la tapa (A) en la tapa (B). Apriete bien los tornillos.

**Gentile cliente,**

La ringraziamo per l'acquisto del dispositivo. La preghiamo di leggere attentamente le seguenti istruzioni d'uso e di seguirle per prevenire eventuali guasti. Non ci assumiamo alcuna responsabilità per danni scaturiti da una mancata osservanza delle indicazioni relative alla sicurezza e da un uso improprio del dispositivo. Scansiona il codice QR seguente per accedere al manuale d'uso più attuale e ricevere informazioni sul prodotto.



---

**INDICE**

---

Singoli componenti 20

Assemblaggio 21

---

**PRODUTTORE E IMPORTATORE (UK)**

---

**Produttore:**

Chal-Tec GmbH, Wallstraße 16, 10179 Berlino, Germania.

**Importatore per la Gran Bretagna:**

Berlin Brands Group UK Limited

PO Box 42

272 Kensington High Street

London, W8 6ND

United Kingdom

## SINGOLI COMPONENTI

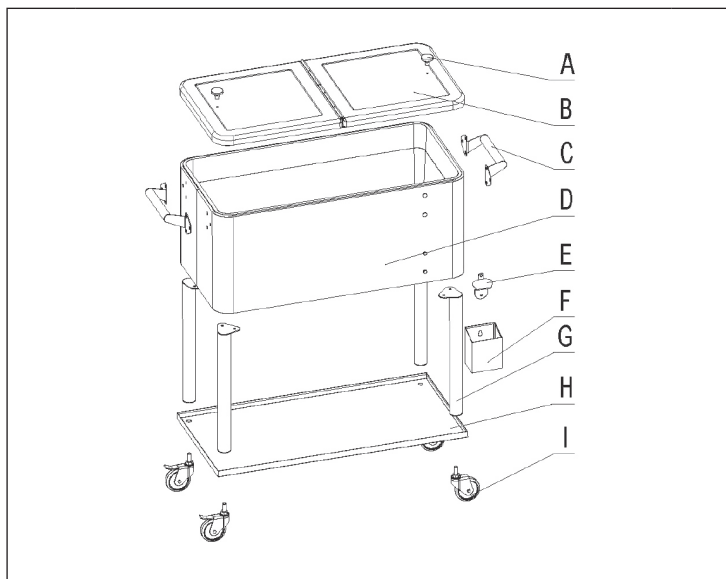

N.	Denominazione	Pz.
A	Maniglia del coperchio	2
B	Coperchio	1
C	Maniglia del carrello	2
D	Portabevande	1
E	Apribottiglie	1
F	Raccoglitore per tappi di bottiglia	1
G	Gamba	4
H	Ripiano in basso	1
I	Ruote (2 con e 2 senza freno)	4
AA	Vite esagonale M6x16	8
BB	Vite a esagono cavo M6x16	14
CC	Bullone calibrato M6x16	2
DD	Vite M5x35	2

## ASSEMBLAGGIO

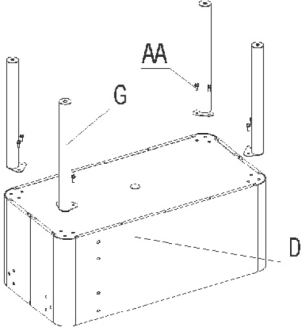
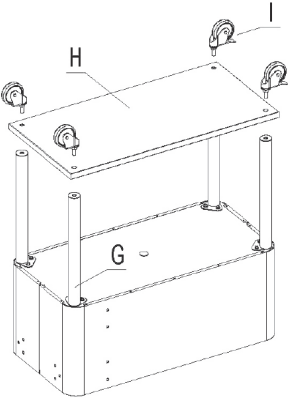
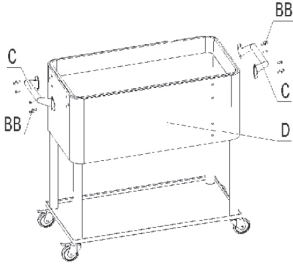
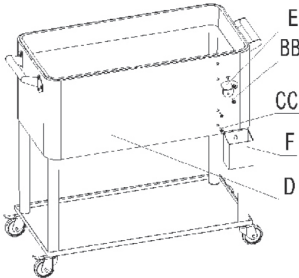
1	2
	
<p>Avvitare le 4 gambe (G) alla cassa. Utilizzare le viti a testa esagonale (AA).</p>	<p>Avvitare le 4 gambe (G) alla cassa. Posizionare le ruote sui fori. Non avvitare ancora del tutto le viti.</p>
3	4
	
<p>Avvitare le due maniglie (C) alla cassa (D) con le viti a esagono cavo (BB). Stringere saldamente le viti.</p>	<p>Avvitare l'apribottiglie (E) alla cassa (D) con le viti ad esagono cavo (BB). Posizionare il raccoglitore per i tappi di bottiglia e montarlo con le viti (DD).</p>

5

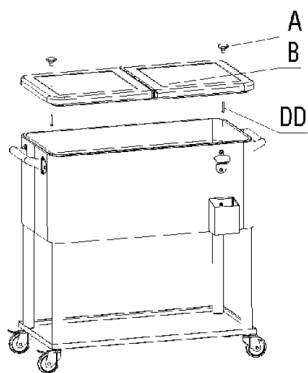

Montare la maniglia del coperchio (A) sul coperchio (B). Stringere saldamente le viti.



