



blumfeldt



Mandala

Gartenkamin

Garden chimney

Chimenea de jardín

Cheminée de jardin

Caminetto da giardino

10030147

Sehr geehrter Kunde,

wir gratulieren Ihnen zum Erwerb Ihres Gerätes. Lesen Sie die folgenden Hinweise sorgfältig durch und befolgen Sie diese, um möglichen Schäden vorzubeugen. Für Schäden, die durch Missachtung der Hinweise und unsachgemäßen Gebrauch entstehen, übernehmen wir keine Haftung. Scannen Sie den folgenden QR-Code, um Zugriff auf die aktuellste Bedienungsanleitung und weitere Informationen rund um das Produkt zu erhalten:



INHALTVERZEICHNIS

Sicherheitshinweise 4
Einzelteile 6
Zusammenbau 7
Reinigung und Pflege 10

English 11
Español 19
Français 27
Italiano 35

HERSTELLER & IMPORTEUR (UK)

Hersteller:

Chal-Tec GmbH, Wallstraße 16, 10179 Berlin, Deutschland.

Importeur für Großbritannien:

Chal-Tec UK limited
Unit 6 Riverside Business Centre
Brighton Road
Shoreham-by-Sea
BN43 6RE
United Kingdom

SICHERHEITSHINWEISE



WARNUNG

Erstickungsgefahr! Die Feuerstelle ist nur zur Nutzung im Freien bestimmt. Sie darf nicht in Gebäuden, Garagen oder anderen geschlossenen Bereichen verwendet werden. Es können sich giftige Dämpfe bilden, die zum Erstickten führen.











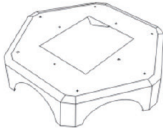

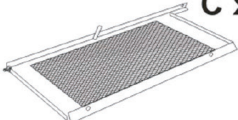
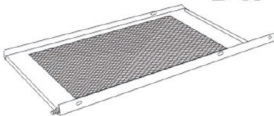
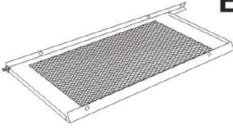
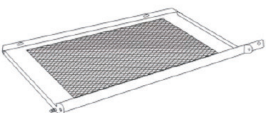
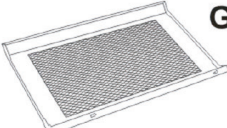
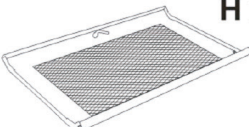
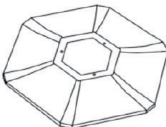

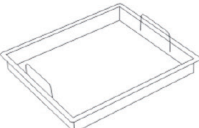
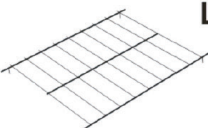
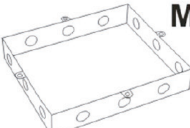
- Die Feuerstelle ist nicht für gewerbliche Zwecke geeignet.
- Die Feuerstelle darf nur von Erwachsenen verwendet werden. Kinder und Haustiere müssen einen sicheren Abstand einhalten.
- Verwenden Sie zum Anzünden kein Benzin, Brennspritus, Feuerzeugbenzin oder Alkohol.
- Benutzen Sie die Feuerstelle nicht, bevor sie nicht vollständig zusammengebaut wurde und alle Teile fest sitzen.
- Verwenden Sie die Feuerstelle nicht auf Untergründen aus Holz oder anderen brennbaren Materialien.
- Leeren Sie die Feuerstelle nach jeder Verwendung. Lassen Sie eine dünne Ascheschicht darin, um den Boden zu schützen. Nehmen Sie die Asche erst heraus, wenn die Kohle komplett abgebrannt und die Asche abgekühlt ist.
- Fassen Sie die Feuerstelle erst an, wenn sie komplett abgekühlt ist. Tragen Sie während des Betriebs hitzebeständige Handschuhe.
- Verstauen Sie die Feuerstelle erst, wenn sie komplett abgekühlt ist und die Asche entsorgt wurde.
- Verwenden Sie immer Werkzeuge und hitzebeständige Handschuhe, wenn Sie Brennmaterial hinzufügen oder die Feuerstelle bewegen.
- Lassen Sie die Feuerstelle während der Benutzung nicht unbeaufsichtigt.
- Während der Benutzung kann heiße Glut aus der Feuerstelle fallen.
- Überladen Sie die Feuerstelle nicht mit Brennmaterial. Fügen Sie erst dann neues Brennmaterial hinzu, wenn das Feuer heruntergebrannt ist. Wenn ein Teil der Feuerstelle rot glüht, ist sie überladen.
- Halten Sie den Brennstoff von Wand der Feuerstelle fern, da die Wand von hohen Temperaturen beschädigt werden kann.
- Atmen Sie den Rauch nicht ein und lassen Sie ihn nicht in die Ihre Augen kommen.
- Untersuchen Sie die Feuerstelle vor der Benutzung auf Beschädigungen.
- Durch die Benutzung kann sich die Metalloberfläche leicht verfärben.

Besondere Hinweise zu Grillgeräten

- Legen Sie das Grillgut erst auf, wenn der Brennstoff mit einer Ascheschicht bedeckt ist!
- Das Gerät wird sehr heiß und darf während des Betriebes nicht bewegt werden.
- Benutzen Sie da Gerät nicht in geschlossenen Räumen.
- Verwenden Sie zum Entzünden oder Wiederentzünden keinen Spiritus oder Benzin verwenden. Verwenden Sie nur Anzündhilfen entsprechend EN 1860-3.
- Halten Sie Kinder und Haustiere vom Gerät fern.

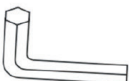

EINZELTEILE

 <p>A x 1</p>	 <p>B x 2</p>	 <p>C x 1</p>	
 <p>D x 1</p>	 <p>E x 1</p>	 <p>F x 1</p>	
 <p>G x 1</p>	 <p>H x 1</p>	 <p>I x 1</p>	
 <p>J x 1</p>	 <p>K x 1</p>	 <p>L x 1</p>	
 <p>M x 1</p>	 <p>N x 1</p>	 <p>O x 3</p>	
<p>P x 1</p> 	<p>Q X 6</p>  <p>M6X10</p>	<p>R X 3</p>  <p>M6X6</p>	<p>S x 21</p>  <p>Mx12</p>
<p>T x 33</p>  <p>M6</p>			

ZUSAMMENBAU

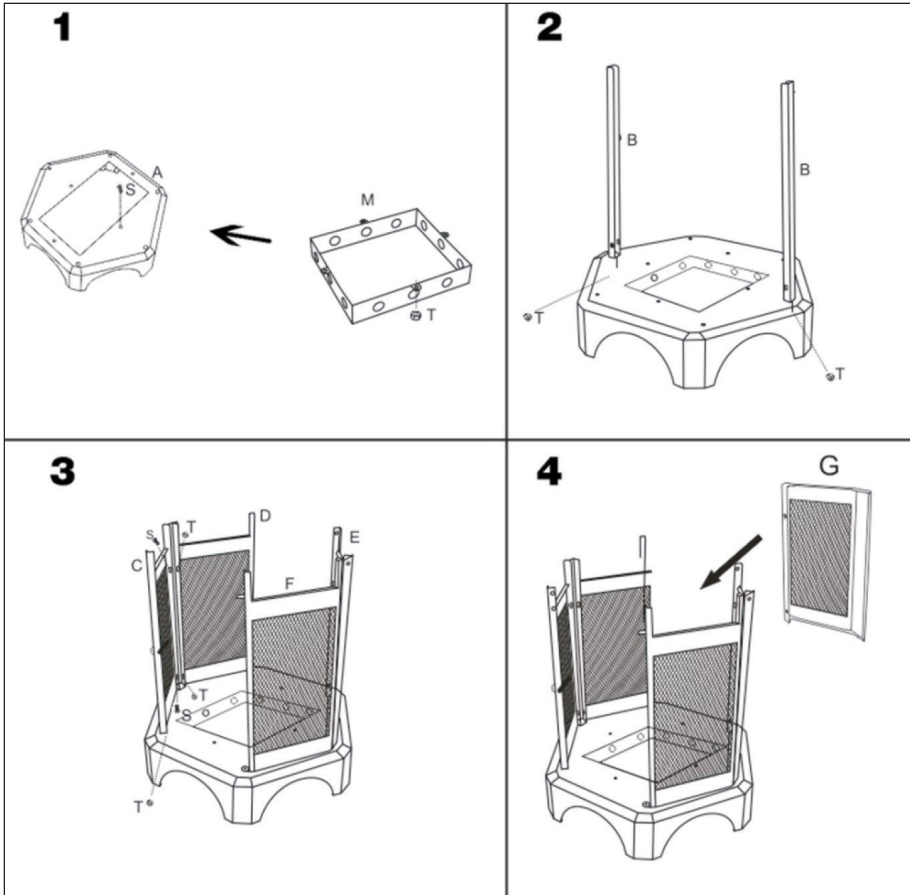

1. Die Feuerschale in die Basis einsetzen.
2. Montieren der beiden Pfeiler (B) mit den Schrauben Mx12 (S) und den Mutterschrauben (T).
3. Einsetzen der Seitengitter (C, D, E, F). Schrauben Sie die Seitenteile an den Pfeilern fest.
4. Einsetzen der hinteren Gitterwand.

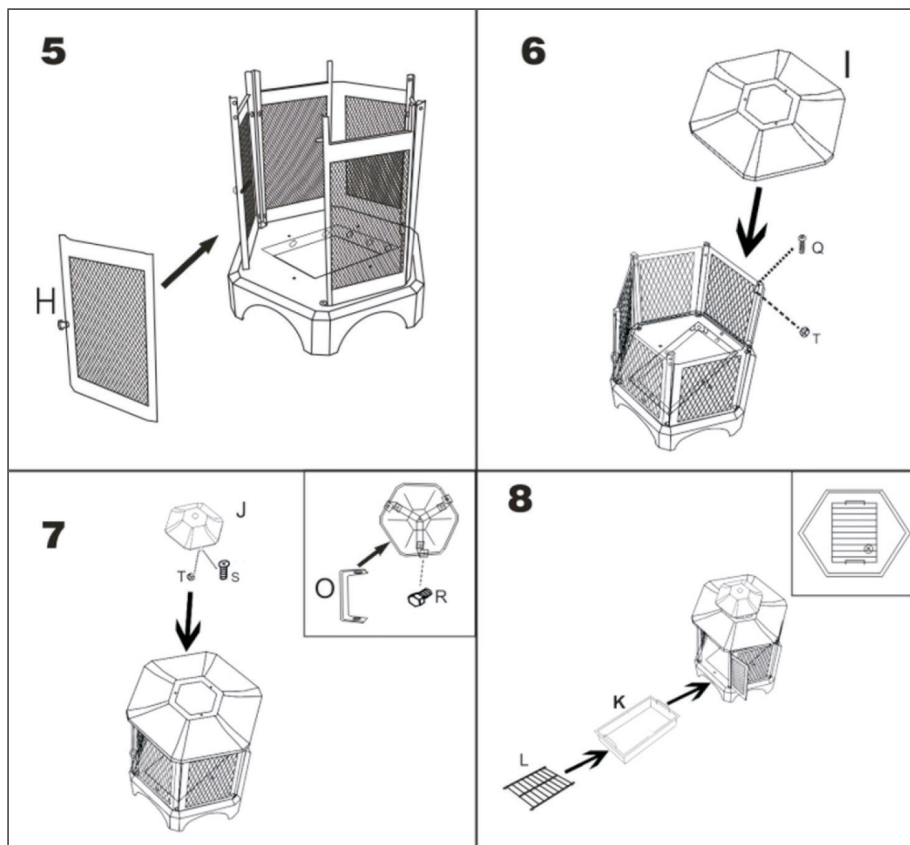

5. Tür einhängen.
6. Dach (I) aufsetzen und mit den Schrauben M6x10 (Q) befestigen.
7. Kaminhaube aufsetzen. Die Inbusschrauben von unten mit dem Sechskantschlüssel festziehen.
8. Aschewanne und Rost hineinlegen.

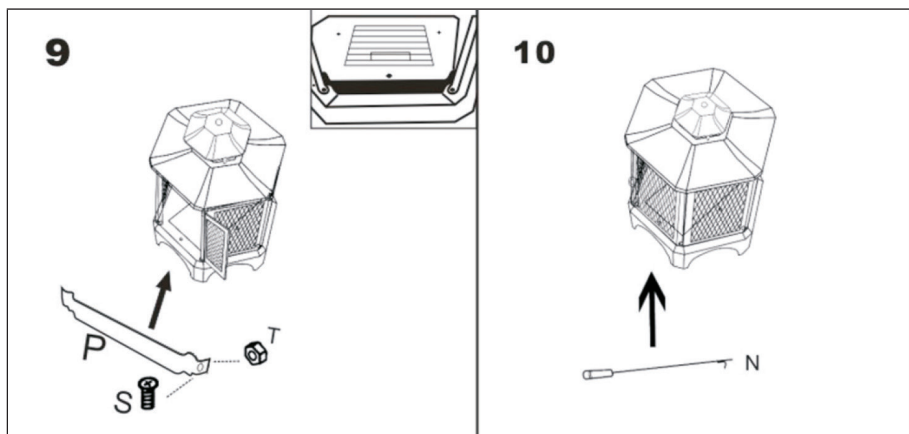

9. Blende mit den Schrauben Mx12 (S) befestigen.
10. Schürhaken zur Verwendung bereithalten.

REINIGUNG UND PFLEGE

**VORSICHT**

Verbrennungsgefahr! Lassen Sie die Feuerstelle vollständig abkühlen, bevor Sie sie auf Schäden untersuchen oder reinigen.

Die Feuerstelle auf Schäden untersuchen

Überprüfen Sie die Feuerstelle regelmäßig auf Schäden, um die Produktsicherheit und eine längere Lebensdauer zu gewährleisten.

1. Überprüfen Sie alle Teile, um sicherzustellen, dass sie fest sitzen.
2. Prüfen Sie die Komponenten auf Beschädigungen.
3. Wenn Sie Schäden an einer Komponente feststellen, lassen Sie die Feuerstelle reparieren, bevor Sie sie weiter benutzen.

Reinigung

- Versichern Sie sich, dass das Feuer vollständig gelöscht ist, wenn Sie die Feuerstelle nicht mehr verwenden.
- Stellen Sie sicher, dass das Feuer vollständig gelöscht ist und die Feuerstelle abgekühlt ist, bevor Sie die Asche entfernen.
- Verwenden Sie ein feuchtes Baumwolltuch, um Ruß zu entfernen. Reinigen Sie die Feuerstelle regelmäßig, um eine lange Lebensdauer zu gewährleisten.

Hinweis: Nach mehrmaligem Gebrauch kann sich die Oberfläche verfärben.

- Verwenden Sie keinen Ofenreiniger oder Scheuermittel, da diese das Produkt beschädigen können.
- Reinigen Sie die Außenseite mit Wasser und einem milden Geschirrspülmittel.
- Verwenden Sie bei hartnäckigen Flecken Sie einen Reiniger auf Zitrusbasis und eine Nylon-Bürste.

Dear Customer,

Congratulations on purchasing this device. Please read the following instructions carefully and follow them to prevent possible damages. We assume no liability for damage caused by disregard of the instructions and improper use. Scan the QR code to get access to the latest user manual and more product information.



CONTENTS

Safety Instructions 12
Individual Parts 14
Assembly 15
Cleaning and Care 18

MANUFACTURER & IMPORTER (UK)

Manufacturer:

Chal-Tec GmbH, Wallstrasse 16, 10179 Berlin, Germany.

Importer for Great Britain:

Chal-Tec UK limited
Unit 6 Riverside Business Centre
Brighton Road
Shoreham-by-Sea
BN43 6RE
United Kingdom

SAFETY INSTRUCTIONS

**WARNING**

Risk of suffocation! This fire pit is for outdoor use only and shall not be used in a building, garage or any other enclosed area. Toxic carbon monoxide fumes can accumulate and cause asphyxiation.











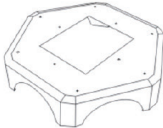

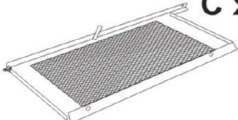
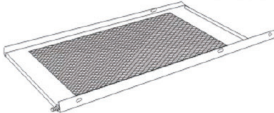
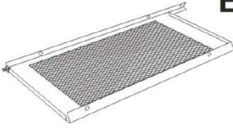
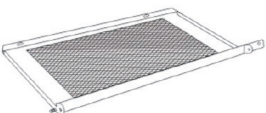
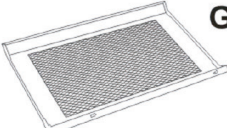
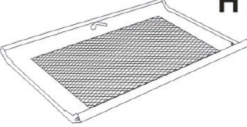
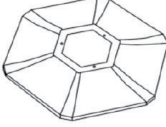

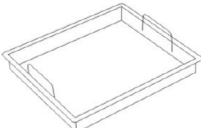

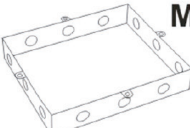
- This fire pit is not for commercial use.
- This fire pit should only be used by adults and all children and pets should be kept at a safe distance.
- Do not use petrol, white spirit, lighter fluid, alcohol or other similar chemicals to light a fire as a rapid increase in temperature could damage the fire pit. This fire pit is only suitable for use with charcoal, untreated wood or dry logs. Do not use coal.
- Do not use this fire pit until it is completely assembled and all parts are securely fastened and tightened.
- Do not use the fire pit on decking or any other flammable surfaces such as dry grass, wood chips, leaves.
- Always empty this fire pit after use. Leave a thin layer of ash to protect the bottom. Do not remove ashes or charcoal until they are completely and fully extinguished.
- Do not touch the fire pit until it is completely cooled unless you are wearing heat resistant gloves as it is hot when in use.
- Do not handle or move the fire pit when in use as it is hot.
- Do not attempt to store the fire pit until all ashes and charcoals are completely extinguished.
- Always use a safety tool and heat resistant gloves when adding or moving fuel.
- Do not leave a burning fire unattended.
- Fire hazard-Hot embers may emit while in use.
- Do not overload the fire pit with fuel. Do not add additional fuel until the fire burns down. If an portion of the fire bowl is growing red, it is overloaded.
- Do not burn fuel directly on the fire bowl base.
- Do keep the fuel away from the wall of the fire pit as the high temperature may damage it.
- Avoid breathing smoke from the fire and avoid getting it into your eyes.
- Always thoroughly inspect the fire pit before use.
- A slight discolouration of finish may occur after use.

Special instructions for grills

- Do not place the food on the grill until the fuel is covered with a layer of ash!
- The appliance becomes very hot and must not be moved during operation.
- Do not use the appliance in closed rooms.
- Do not use spirit or petrol for ignition or re-ignition. Only use ignition aids in accordance with EN 1860-3.
- Keep children and pets away from the appliance.

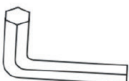

INDIVIDUAL PARTS

 <p>A x 1</p>	 <p>B x 2</p>	 <p>C x 1</p>	
 <p>D x 1</p>	 <p>E x 1</p>	 <p>F x 1</p>	
 <p>G x 1</p>	 <p>H x 1</p>	 <p>I x 1</p>	
 <p>J x 1</p>	 <p>K x 1</p>	 <p>L x 1</p>	
 <p>M x 1</p>	 <p>N x 1</p>	 <p>Ox3</p>	
<p>Px1</p> 	<p>Q X 6</p>  <p>M6X10</p>	<p>R X 3</p>  <p>M6X6</p>	<p>Sx21</p>  <p>Mx12</p>
<p>Tx33</p>  <p>M6</p>			

ASSEMBLY

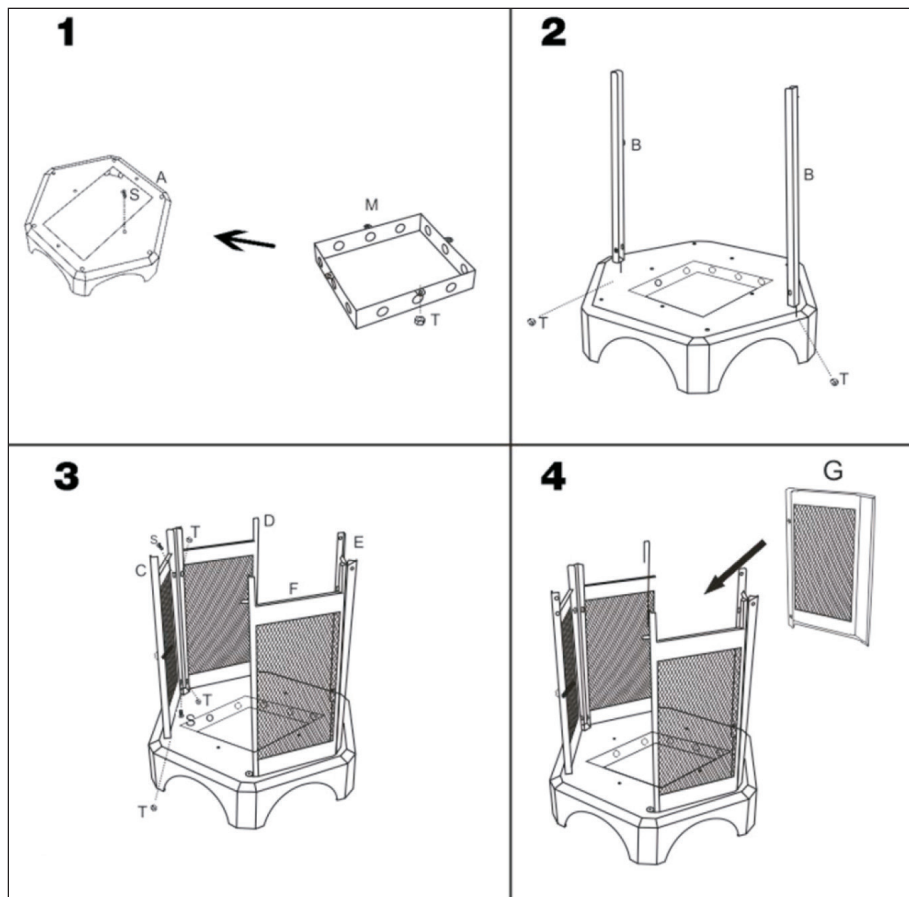

1. Insert the fire bowl into the base.
2. Assemble the two pillars (B) with the Mx12 screws (S) and the nut screws (T).
3. Insert the side grids (C, D, E, F). Screw the side grids to the abutments.
4. Insert the rear grating wall.

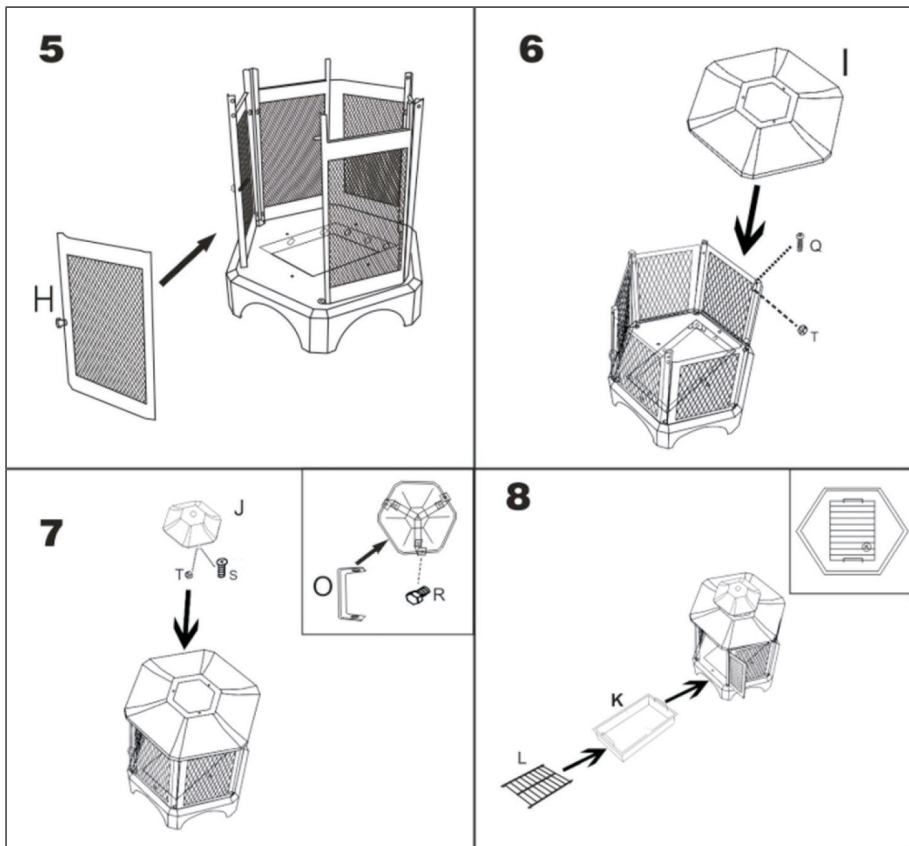

5. Hook in the door.
6. Put on roof (I) and fix it with the screws M6x10 (Q).
7. Put on the chimney hood. Tighten the allen screws from below with the hexagonal wrench.
8. Place the ash pan and grate inside.

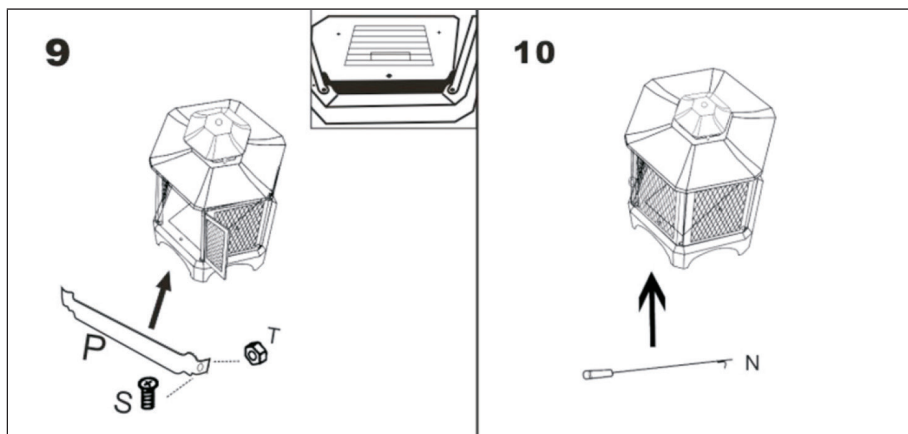

9. Fasten the cover with the Mx12 screws (S).
10. Have the poker ready for use.

CLEANING AND CARE

**CAUTION**

Danger of burns! Allow the fireplace to cool completely before inspecting or cleaning it for damage.

Inspect the fireplace for damage

Check the fireplace regularly for damage to ensure product safety and a longer service life.

1. Check all parts to make sure they are tight.
2. Check the components for damage.
3. If you find damage to a component, have the fireplace repaired before continuing to use it.

Cleaning

- Make sure that the fire is completely extinguished when you no longer use the fireplace.
- Make sure the fire is completely extinguished and the fireplace has cooled down before removing the ashes.
- Use a damp cotton cloth to remove soot. Clean the fireplace regularly to ensure a long service life.

Note: The surface may discolour after repeated use.

- Do not use oven cleaner or scouring agents, as these can damage the product.
- Clean the outside with water and a mild dishwashing liquid.
- For stubborn stains, use a citrus-based cleaner and a nylon brush.

Estimado cliente:

Le felicitamos por la adquisición de este producto. Lea atentamente el siguiente manual y siga cuidadosamente las instrucciones de uso con el fin de evitar posibles daños. La empresa no se responsabiliza de los daños ocasionados por un uso indebido del producto o por haber desatendido las indicaciones de seguridad. Escanee el código QR para obtener acceso al manual de usuario más reciente y otra información sobre el producto.



ÍNDICE DE CONTENIDOS

Indicaciones de seguridad 20
Piezas individuales 22
Montaje 23
Limpieza y cuidado 26

FABRICANTE E IMPORTADOR (REINO UNIDO)

Fabricante:

Chal-Tec GmbH, Wallstraße 16, 10179 Berlín, Alemania.

Importador para Gran Bretaña:

Chal-Tec UK limited
Unit 6 Riverside Business Centre
Brighton Road
Shoreham-by-Sea
BN43 6RE
United Kingdom

INDICACIONES DE SEGURIDAD



ADVERTENCIA

¡Riesgo de asfixia! La chimenea de jardín está concebida para utilizarse únicamente en el exterior. No debe utilizarse en un edificio, garaje o área cerrada. Se pueden crear humos tóxicos y provocar asfixia.











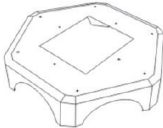

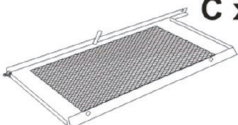
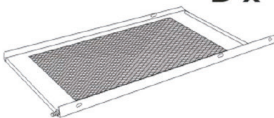
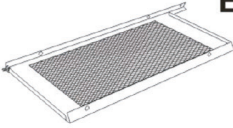
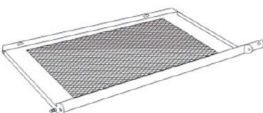
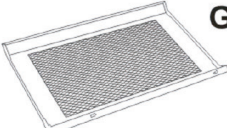
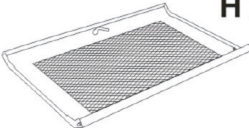
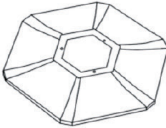

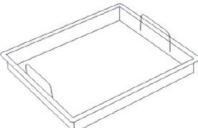

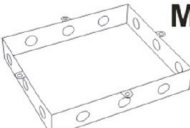
- La chimenea no está diseñada para fines comerciales.
- Solamente un adulto debe operar la chimenea. Mantenga a niños y mascotas a una distancia segura.
- No utilice gasolina, alcohol, gasolina para encendedores ni otros líquidos explosivos para encender la chimenea.
- Utilice la chimenea únicamente después de haberla montado completamente y comprobado que todas sus piezas están correctamente atornilladas.
- No instale la chimenea sobre superficies hechas de madera u otros materiales inflamables.
- Vacíe la chimenea después de cada uso. Deje una capa fina de cenizas para proteger el fondo. Retire las cenizas cuando las brasas se hayan apagado y la chimenea se haya enfriado.
- No toque la chimenea hasta que se haya enfriado; utilice guantes resistentes al calor durante el manejo de la misma.
- Guarde la chimenea después de que se haya enfriado y haya retirado las cenizas.
- Utilice siempre utensilios y guantes resistentes al calor cuando añada el material combustible o mueva la chimenea.
- No deje la chimenea sin supervisión cuando está encendida.
- Durante el uso, puede salir brasa muy caliente de la chimenea.
- No llene en exceso la chimenea con material de combustión. Añada más material combustible cuando el fuego se esté apagando. Si una parte de la chimenea se ilumina en rojo, significa que está llena en exceso.
- No coloque el material combustible cerca de las paredes de la chimenea, ya que las altas temperaturas las podrían dañar.
- No inhale el humo y evite que entre en contacto con sus ojos.
- Inspeccione la chimenea antes de cada uso para detectar cualquier deterioro.
- La superficie de metal puede decolorarse un poco por el uso.

Instrucciones especiales para parrillas

- No coloque los alimentos en la parrilla hasta que el combustible esté cubierto con una capa de ceniza!
- El aparato se calienta mucho y no debe moverse durante el funcionamiento.
- No utilice el aparato en espacios cerrados.
- No utilice alcohol o gasolina para el encendido o reencendido. Utilizar únicamente dispositivos auxiliares de encendido conforme a la norma EN 1860-3.
- Mantenga a los niños y a las mascotas alejados del aparato.

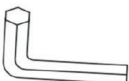

PIEZAS INDIVIDUALES

 <p>A x 1</p>	 <p>B x 2</p>	 <p>C x 1</p>	
 <p>D x 1</p>	 <p>E x 1</p>	 <p>F x 1</p>	
 <p>G x 1</p>	 <p>H x 1</p>	 <p>I x 1</p>	
 <p>J x 1</p>	 <p>K x 1</p>	 <p>L x 1</p>	
 <p>M x 1</p>	 <p>N x 1</p>	 <p>O x 3</p>	
<p>P x 1</p> 	<p>Q X 6</p>  <p>M6X10</p>	<p>R X 3</p>  <p>M6X6</p>	<p>S x 21</p>  <p>Mx12</p>
<p>T x 33</p>  <p>M6</p>			

MONTAJE

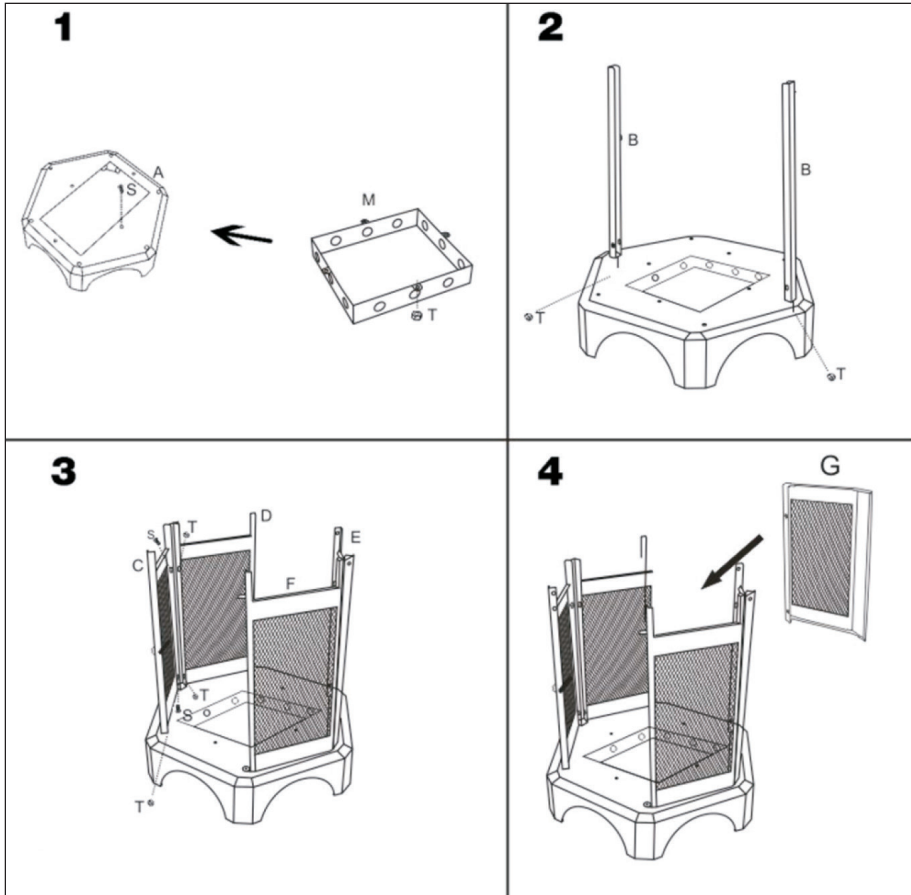

1. Inserte el recipiente del fuego en la base.
2. Ensamble los dos pilares (B) con los tornillos Mx12 (S) y los tornillos de tuerca (T).
3. Inserte los rieles laterales (C, D, E, F). 3. Atornille las barandillas laterales a los pilares.
4. Insertar la pared de la rejilla trasera.

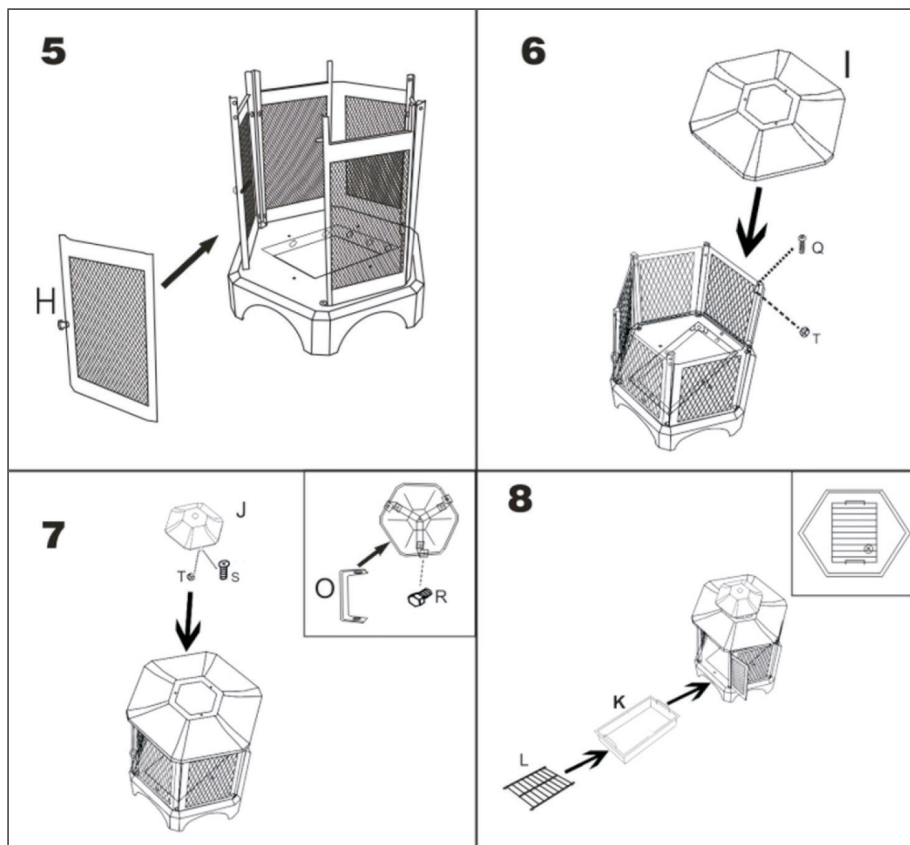

5. Colgar la puerta.
6. Coloque el techo (I) y fíjelo con los tornillos M6x10 (Q).
7. Ponte el gorro de la chimenea. Apriete los tornillos Allen desde abajo con la llave hexagonal.
8. Coloque el cajón de la ceniza y la rejilla en el interior.

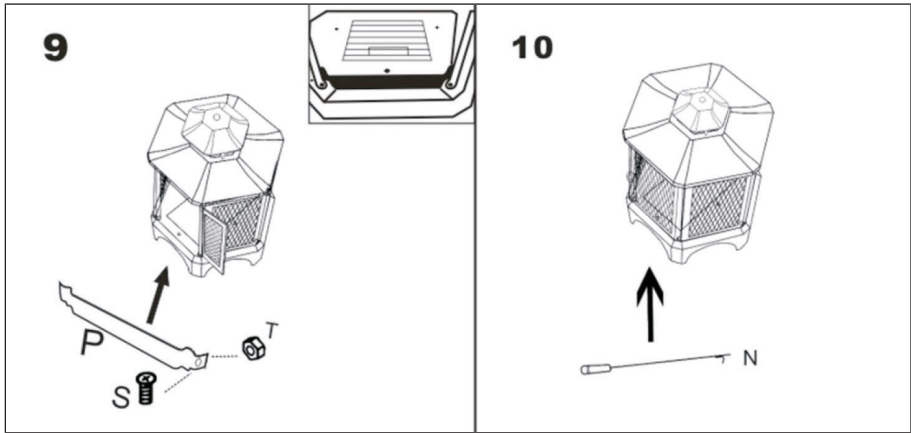

9. Fije la pantalla con los tornillos Mx12 (S).
10. Tener el atizador listo para su uso.

LIMPIEZA Y CUIDADO

**ATENCIÓN:**

¡Riesgo de quemaduras! Deje que la chimenea se enfríe por completo antes de limpiarla o examinarla para detectar cualquier deterioro.

Examinar la chimenea

Inspeccione regularmente la chimenea para detectar posibles daños y, de este modo, garantizar la seguridad del producto y una mayor vida útil.

1. Inspeccione todas las piezas para asegurar que están bien atornilladas.
2. Revise las piezas para detectar cualquier deterioro u oxidación.
3. Si detecta cualquier deterioro, repárelo antes de volver a utilizar la chimenea.

Limpieza

- Compruebe que el fuego está completamente apagado si no utiliza más la chimenea.
- Asegúrese de que el fuego está completamente apagado y la chimenea enfriada antes de retirar las cenizas.
- Utilice un paño de algodón húmedo para retirar el hollín de la tapa de rejilla y la tapa de chimenea. Limpie regularmente la chimenea para asegurar una mayor vida útil.

Atención: la superficie puede decolorarse después de varios usos.

- No utilice limpiadores para hornos ni agentes abrasivos, ya que pueden dañar el producto.
- Limpie el exterior con agua y un lavavajillas suave.
- Para manchas difíciles, use un limpiador a base de cítricos y un cepillo de nylon.

Cher client,

Toutes nos félicitations pour l'acquisition de ce nouvel appareil. Veuillez lire attentivement les instructions suivantes de branchement et d'utilisation afin d'éviter d'éventuels dommages. Le fabricant ne saurait être tenu pour responsable des dommages dus au non-respect des consignes de sécurité et à la mauvaise utilisation de l'appareil. Scannez le QR-Code pour accéder à la dernière version du mode d'emploi et à d'autres informations concernant le produit.



SOMMAIRE

Consignes de sécurité 28

Pièces détachées 30

Montage 31

Nettoyage et entretien 34

FABRICANT ET IMPORTATEUR (UK)

Fabricant :

Chal-Tec GmbH, Wallstraße 16, 10179 Berlin, Allemagne.

Importateur pour la Grande Bretagne :

Chal-Tec UK limited

Unit 6 Riverside Business Centre

Brighton Road

Shoreham-by-Sea

BN43 6RE

United Kingdom

CONSIGNES DE SÉCURITÉ



MISE EN GARDE

Risque d'étouffement ! Le braséro est destiné à un usage extérieur seulement. Il ne doit pas être utilisé dans des bâtiments, garages ou autres espaces clos. Il peut former des fumées toxiques qui provoquent la suffocation.











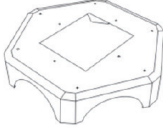

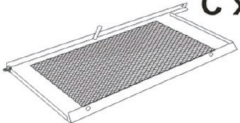
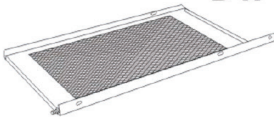
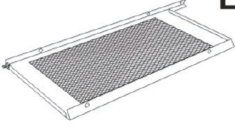
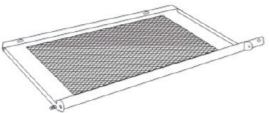
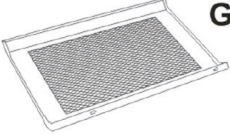
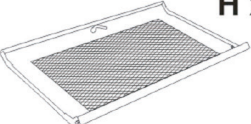
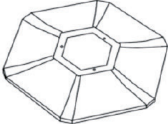

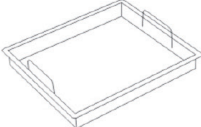

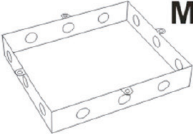
- Le braséro ne convient pas à un usage commercial.
- Le braséro ne peut être utilisé que par des adultes. Les enfants et les animaux de compagnie doivent garder une distance de sécurité.
- N'utilisez pas d'essence, d'alcool à brûler, de liquide léger ou d'alcool pour l'éclairage.
- N'utilisez pas le braséro tant qu'il n'est pas complètement assemblé et que toutes les pièces sont serrées.
- N'utilisez pas le braséro sur du bois ou d'autres matériaux combustibles.
- Videz le braséro après chaque utilisation. Laissez une fine couche de cendre pour protéger le fond. Ne retirez les cendres que lorsque le charbon a complètement brûlé et que les cendres se sont refroidies.
- Ne touchez pas le braséro avant qu'il ne soit complètement refroidi ; portez des gants résistant à la chaleur pendant le fonctionnement.
- Ne rangez le braséro que lorsqu'il est complètement refroidi et que les cendres ont été éliminées.
- Utilisez toujours des outils et des gants résistant à la chaleur pour ajouter du carburant ou déplacer le braséro.
- Ne laissez pas le braséro sans surveillance pendant l'utilisation.
- Pendant l'utilisation, des braises chaudes peuvent tomber du braséro.
- Ne surchargez pas le braséro avec du carburant. Ajoutez du nouveau carburant seulement lorsque le feu a brûlé. Si une partie du foyer est rouge, cela signifie qu'elle est surchargée.
- Gardez le carburant loin des parois du braséro car la paroi peut être endommagée par les températures élevées.
- N'inhalez pas la fumée et ne la laissez pas entrer dans vos yeux.
- Inspectez le braséro pour vous assurer qu'il n'est pas endommagé avant de l'utiliser.
- La surface métallique peut facilement décolorer au fur et à mesure des utilisations.

Consignes particulières concernant les barbecues

- Ne placez les aliments sur le gril que lorsque le combustible est recouvert d'une fine couche de cendre !
- L'appareil devient très chaud et ne doit pas être déplacé pendant le fonctionnement.
- N'utilisez pas l'appareil à l'intérieur.
- N'utilisez pas d'alcool ou d'essence pour allumer ou raviver le feu. Utilisez uniquement des allume-feu conformément à la norme EN 1860-3.
- Gardez les enfants et les animaux domestiques éloignés de l'appareil.

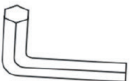

PIÈCES DÉTACHÉES

 A x 1	 B x 2	 C x 1	
 D x 1	 E x 1	 F x 1	
 G x 1	 H x 1	 I x 1	
 J x 1	 K x 1	 L x 1	
 M x 1	 N x 1	 O x 3	
 P x 1	 Q X 6 M6X10	 R X 3 M6X6	 S x 21 Mx12
 T x 33 M6			

MONTAGE

1

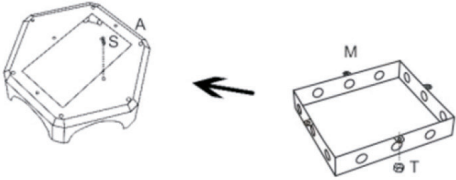

2

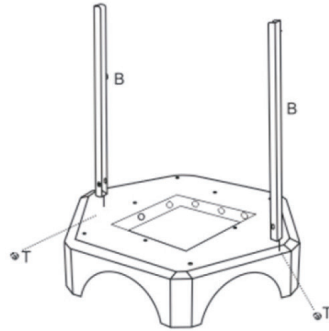

3

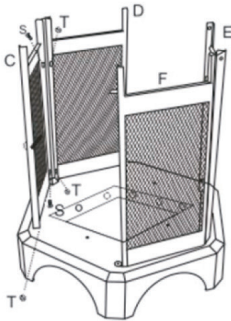

4

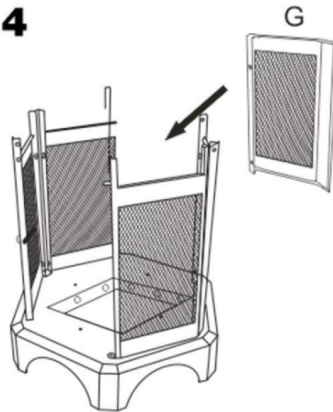

1. Insérez le bol à feu dans la base.
2. Assemblez les deux piliers (B) avec les vis Mx12 (S) et les vis à écrou (T).
3. Insérez les rails latéraux (C, D, E, F). Vissez les rails latéraux aux piliers.
4. Insérez la paroi de la grille arrière.

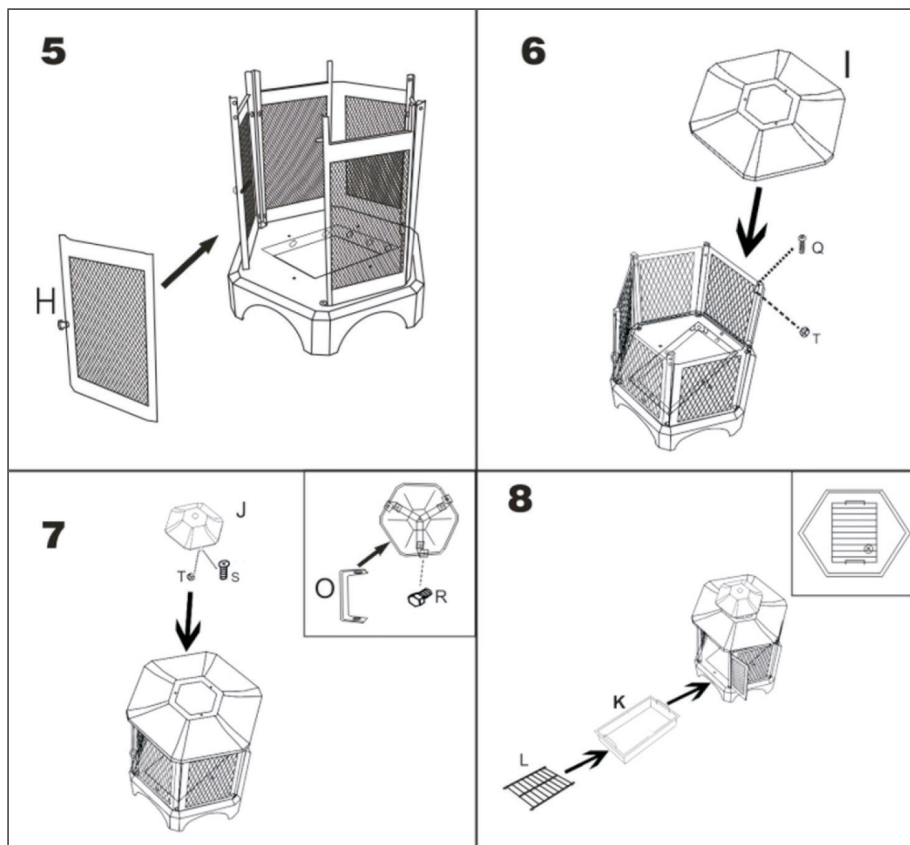

5. Accrochez la porte.
6. Mettre le toit (I) et le fixer avec les vis M6x10 (Q).
7. Mets le bonnet de cheminée. Serrez les vis Allen par le bas avec la clé hexagonale.
8. Placez le bac à cendres et la grille à l'intérieur.

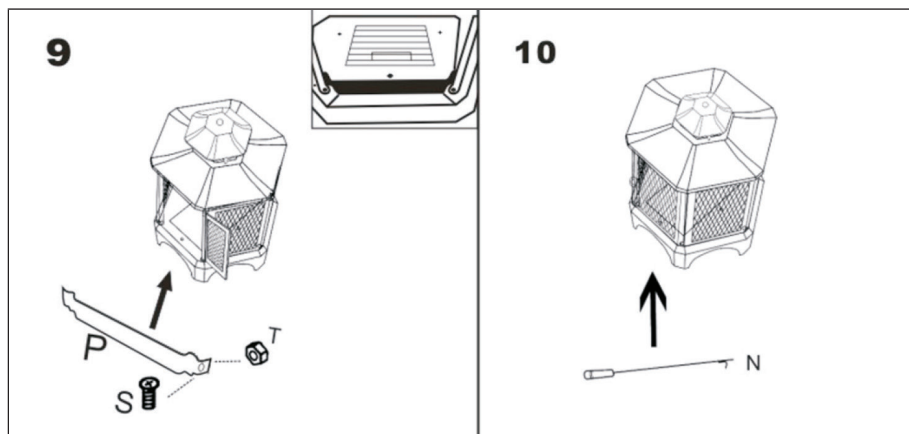

9. Fixez l'écran avec les vis Mx12 (S).
10. Avoir le poker prêt à être utilisé.

NETTOYAGE ET ENTRETIEN



ATTENTION

Risque de brûlure ! Laissez la cheminée refroidir entièrement avant de l'examiner pour rechercher d'éventuels défauts ou de la nettoyer.

Contrôle du bon état de la cheminée

Vérifiez régulièrement la cheminée du jardin pour déceler tout dommage afin d'assurer la sécurité du produit et une plus longue durée de vie.

1. Vérifiez les poignées pour vous assurer qu'elles sont bien serrées.
2. Vérifiez que les éléments sont exempts de dommages et de rouille.
3. Si vous remarquez des dommages sur un élément, faites réparer la cheminée avant de continuer à l'utiliser.

Nettoyage

- Assurez-vous que le feu est complètement éteint lorsque vous cessez d'utiliser la cheminée de jardin.
- Assurez-vous que le feu est complètement éteint et que la cheminée s'est refroidie avant de nettoyer le bac à cendres. Remettez les cendres dans le conteneur à cendres, sortez le conteneur à cendres et videz-le.
- Utilisez un chiffon en coton humide pour enlever la suie du couvercle grillagé et du chapeau de cheminée. Nettoyez la cheminée régulièrement pour lui assurer une grande longévité.

Remarque : les surfaces sont susceptibles de se décolorer après plusieurs utilisations.

- N'utilisez pas de nettoyeur pour four ou d'agents abrasifs, car ils peuvent endommager le produit.
- Nettoyez l'extérieur avec de l'eau et un liquide vaisselle doux.
- Pour les taches tenaces, utilisez un nettoyeur à base d'agrumes et une brosse en nylon.

Gentile cliente,

La ringraziamo per aver acquistato il dispositivo. La preghiamo di leggere attentamente le seguenti istruzioni per l'uso e di seguirle per evitare possibili danni tecnici. Non ci assumiamo alcuna responsabilità per danni scaturiti da una mancata osservazione delle avvertenze di sicurezza e da un uso improprio del dispositivo. Scansionare il codice QR seguente, per accedere al manuale d'uso più attuale e per ricevere informazioni sul prodotto.



INDICE

Avvertenze di sicurezza 36
Parti individuali 38
Montaggio 39
Pulizia e manutenzione 42

PRODUTTORE E IMPORTATORE (UK)

Produttore:

Chal-Tec GmbH, Wallstraße 16, 10179 Berlino, Germania.

Importatore per la Gran Bretagna:

Chal-Tec UK limited
Unit 6 Riverside Business Centre
Brighton Road
Shoreham-by-Sea
BN43 6RE
United Kingdom

AVVERTENZE DI SICUREZZA



ATTENZIONE

Pericolo di soffocamento! Il braciere da giardino è progettato per il solo uso all'aperto. Non può essere utilizzato in edifici, garage o altri ambienti chiusi. Possono formarsi vapori tossici, che provocano il soffocamento.











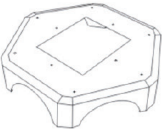

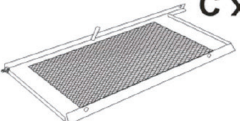
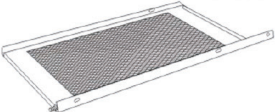
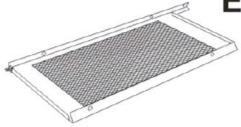
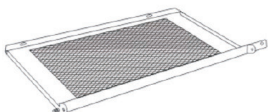
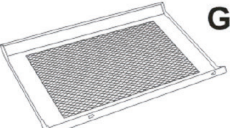
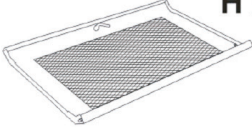
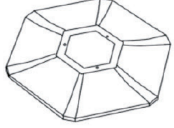

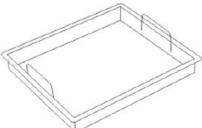

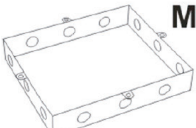
- Il braciere non è adatto a utilizzi commerciali.
- Il braciere può essere utilizzato solo da persone adulte. Tenere bambini e animali domestici a distanza di sicurezza.
- Non utilizzare benzina, spirito, liquido per accendini o alcool per accenderlo.
- Non utilizzare il braciere prima del completo montaggio e prima che tutti i componenti siano saldamente assemblati.
- Non utilizzare il braciere su fondi in legno o in altri materiali infiammabili.
- Svuotare il braciere dopo ogni utilizzo. Lasciare un sottile strato di cenere all'interno per proteggere il fondo. Togliere la cenere solo quando il carbone è completamente bruciato e la cenere si è raffreddata.
- Toccare il braciere solo quando è completamente raffreddato. Durante l'utilizzo, indossare guanti termoresistenti.
- Riporre il braciere solo quando è completamente raffreddato ed è stata rimossa la cenere.
- Quando si aggiunge materiale combustibile o si sposta il braciere, utilizzare sempre utensili e guanti termoresistenti.
- Non lasciare il braciere privo di controllo durante il funzionamento.
- Durante il funzionamento, possono cadere braci fuori dal braciere.
- Non sovraccaricare il braciere con materiale combustibile. Aggiungere combustibile solo quando il fuoco è debole. Se alcune parti del braciere diventano rosse a causa dell'eccessivo calore, è stato inserito troppo materiale combustibile.
- Tenere il combustibile lontano dalla parete del braciere, in quanto temperature elevate potrebbero danneggiarla.
- Non inspirare il fumo e non farlo arrivare negli occhi.
- Controllare il braciere prima dell'utilizzo per eventuali danneggiamenti.
- L'utilizzo può causare un cambiamento di colore delle superfici metalliche.

Avvertenze particolari sui dispositivi per grigliare

- Aggiungere le pietanze da grigliare solo quando il combustibile è coperto da uno strato di cenere!
- Il dispositivo diventa estremamente caldo e non può essere spostato durante l'utilizzo.
- Non utilizzare il dispositivo in locali chiusi.
- Non utilizzare spirito o benzina per accendere o riaccendere il fuoco. Utilizzare solo accenditori conformi a EN 1860-3.
- Tenere bambini e animali domestici lontano dal dispositivo.

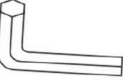

PARTI INDIVIDUALI

 <p>A x 1</p>	 <p>B x 2</p>	 <p>C x 1</p>	
 <p>D x 1</p>	 <p>E x 1</p>	 <p>F x 1</p>	
 <p>G x 1</p>	 <p>H x 1</p>	 <p>I x 1</p>	
 <p>J x 1</p>	 <p>K x 1</p>	 <p>L x 1</p>	
 <p>M x 1</p>	 <p>N x 1</p>	 <p>O x 3</p>	
<p>P x 1</p> 	<p>Q X 6</p>  <p>M6X10</p>	<p>R X 3</p>  <p>M6X6</p>	<p>S x 21</p>  <p>Mx12</p>
<p>T x 33</p>  <p>M6</p>			

MONTAGGIO

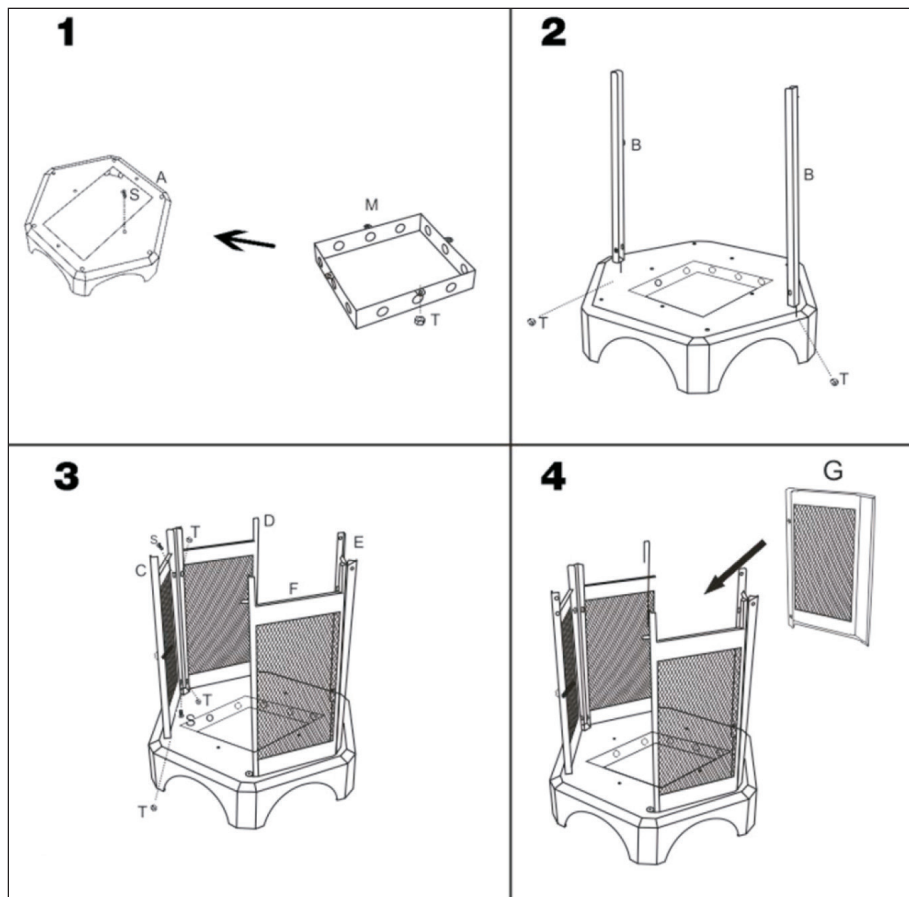

1. Inserire la ciotola del fuoco nella base.
2. Assemblare i due pilastri (B) con le viti Mx12 (S) e le viti a dado (T).
3. Inserire le guide laterali (C, D, E, F). Avvitare le guide laterali ai pilastri.
4. Inserire la parete della griglia posteriore.

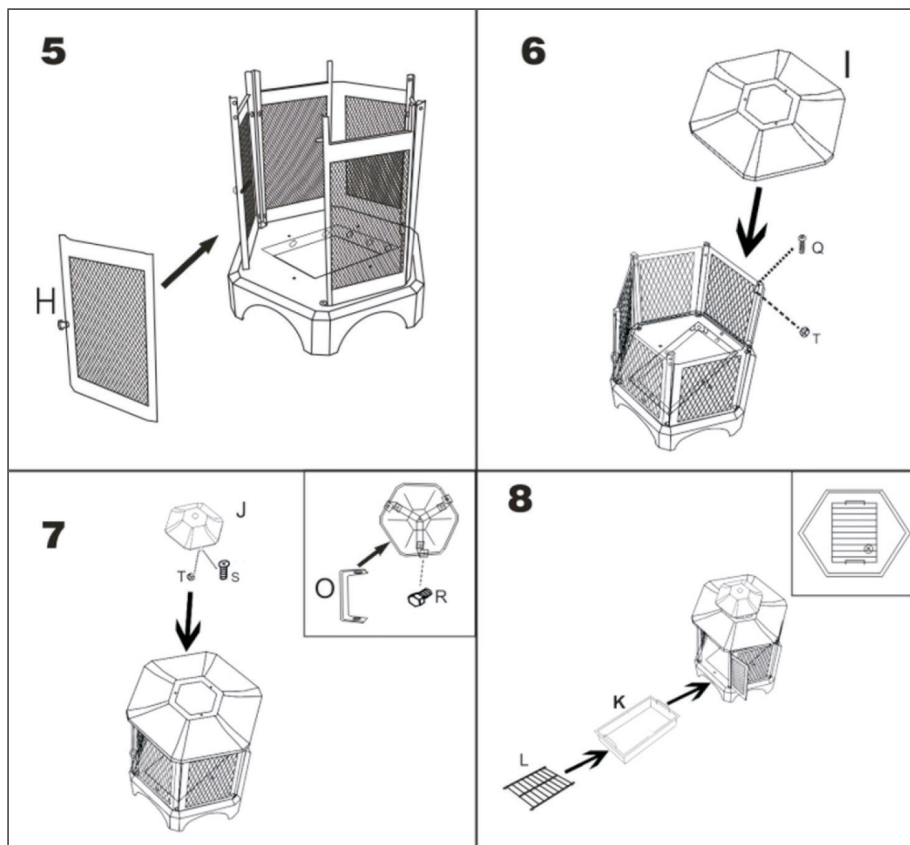

5. Appendere la porta.
6. Mettere il tetto (I) e fissarlo con le viti M6x10 (Q).
7. Mettiti la cuffietta del camino. Serrare le viti a brugola dal basso con la chiave esagonale.
8. Posizionare il cassetto della cenere e la griglia all'interno.

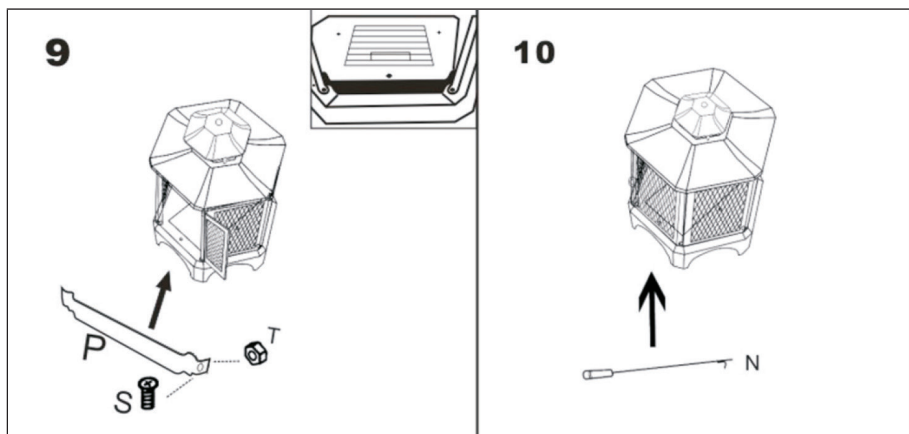

9. Fissare lo schermo con le viti Mx12 (S).
10. Avere l'attizzatoio pronto all'uso.

PULIZIA E MANUTENZIONE

**ATTENZIONE**

Pericolo di ustione! Far raffreddare completamente il camino, prima di controllarlo per eventuali danni o di pulirlo.

Controllare il camino per eventuali danni

Controllare regolarmente se il camino è danneggiato, in modo da garantire sicurezza e durata.

1. Controllare le impugnature per assicurarsi che siano fissate saldamente.
2. Controllare se i componenti sono arrugginiti o danneggiati.
3. Se si nota un componente danneggiato, far riparare il camino prima di utilizzarlo.

Pulizia

- Assicurarsi che il fuoco sia completamente spento, quando non si utilizza più il camino.
- Assicurarsi che il fuoco sia completamente spento e che il camino si sia raffreddato, prima di rimuovere la cenere.
- Utilizzare un panno in cotone umido per rimuovere fuliggine dalla copertura in rete e dal coperchio del comignolo. Pulire regolarmente il camino per garantire una lunga vita utile.

Avvertenza: dopo diversi utilizzi, la superficie può cambiare colore.

- Non utilizzare detersivi per forni o agenti abrasivi, in quanto potrebbero danneggiare il prodotto.
- Pulire l'esterno con acqua e un detersivo delicato.
- Per le macchie ostinate utilizzare un detersivo a base di agrumi e una spazzola di nylon.

