

Smoker-Grill-Lokomotive

10030555

KLARSTEIN







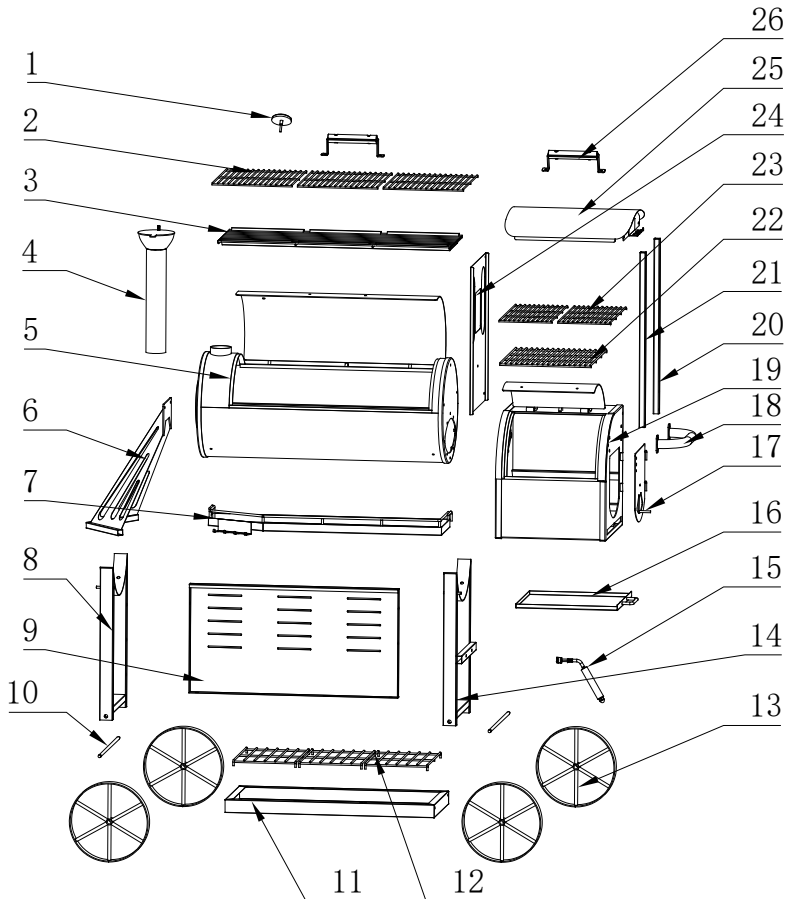









Sehr geehrter Kunde,









wir gratulieren Ihnen zum Erwerb Ihres Gerätes. Lesen Sie die folgenden Hinweise sorgfältig durch und befolgen Sie diese, um möglichen Schäden vorzubeugen. Für Schäden, die durch Missachtung der Hinweise und unsachgemäßen Gebrauch entstehen, übernehmen wir keine Haftung.

Geräteübersicht



Teileliste

Nr.	Teil	Anzahl	Bild
1	Thermometer	1	
2	Großer Rost	3	
3	Kohlenpfanne und Kohlerost	2	
4	Kaminabzug	1	
5	Räucherkammer	1	
6	Zierschürze	2	
7	Vordere Ablage	2	
8	Linkes Bein	2	
9	Teil der hinteren Platte	1	
10	Achse	2	
11	Bodenplatte	1	
12	Bodenregal	3	
13	Rad	4	
14	Rechter Teil des Beins	2	
15	Klappengriff	1	
16	Ascheblech für die Brennkammer	2	
17	Kohlentür für Brennkammer	2	

Nr.	Teil	Anzahl	Bild
18	Seitengriff	1	
19	Bein rechts hinten	1	
20	Zierleiste für die Haltung der Platte vorne	1	
21	Zierleiste für die Haltung der Platte vorne	1	
22	Kohlengitter für die Brennkammer	1	
23	Rost für die Brennkammer	2	
24	Zierblende für Brennkammer	1	
25	Oberseite der Brennkammer	1	
26	Griff für den Deckel	2	

Schrauben

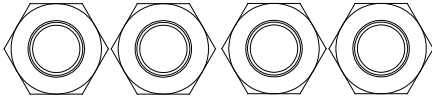

M10 4 Stück

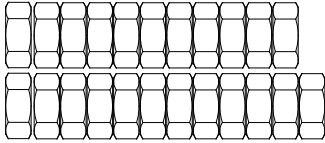

M6 23 Stück

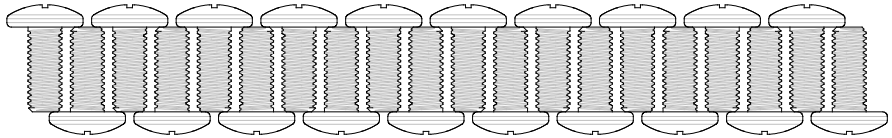
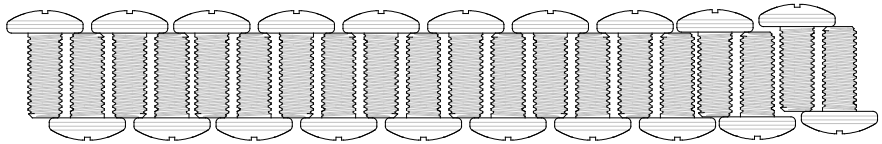
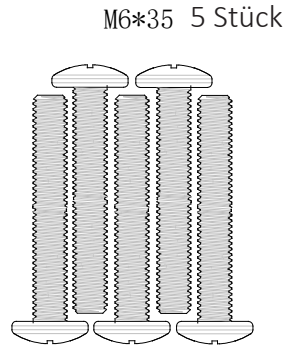

M6*15 40 Stück

A	M6x15 Schrauben	40
B	M6x35 Schrauben	5
C	M6 Gegenmuttern	23
D	M10 Muttern	4

Zusammenbau

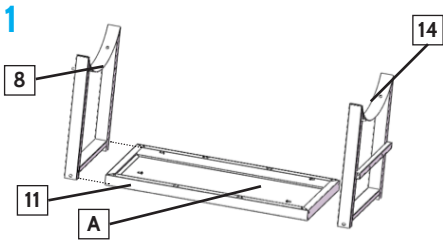

Setzen Sie die Bodenschiene, das linke Bein und das rechte Bein mit den Schrauben (A) zusammen.

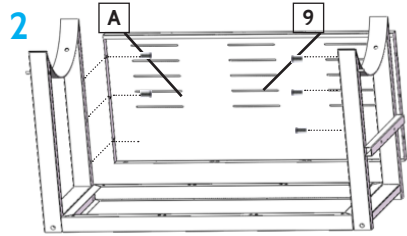

Montieren Sie die hintere Platte mit 6 Schrauben (A).

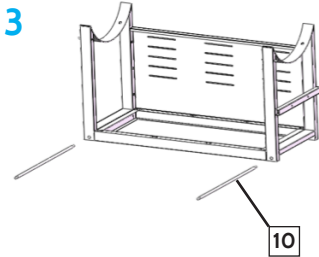

Bringen Sie die Achsen an.

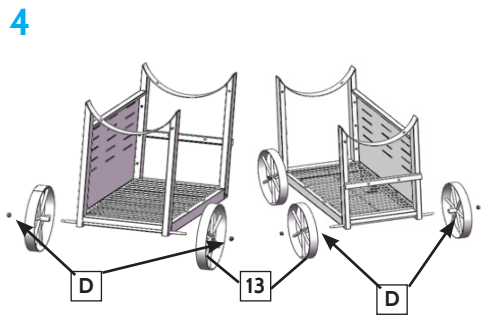

Montieren Sie die Räder mit 4 Muttern (D).

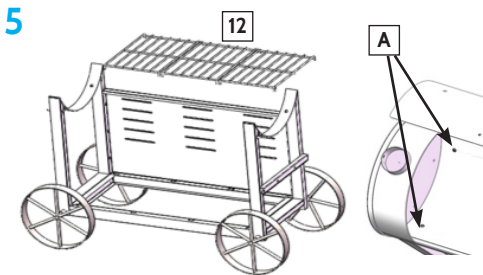

Befestigen Sie das dreiteilige Bodenregal.

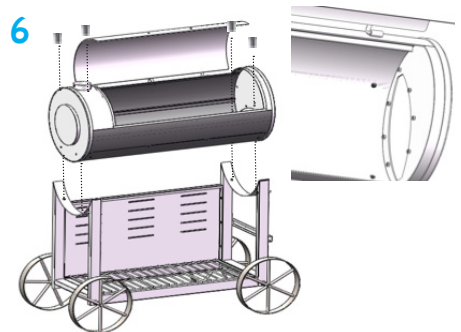

Setzen Sie den Räucherzylinder mit 4 Schrauben (A) und 4 Schrauben (C) zusammen. Die Deckel sind schon montiert.

7

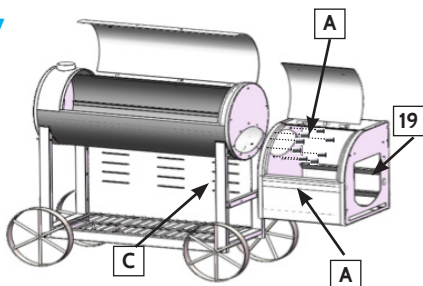

Die Brennkammer mit 10 Schrauben (A) und 2 Schrauben (C) befestigen. Die beiden äußeren Schrauben anbringen. Die Schrauben erst nach der Bestückung der Brennkammer anziehen.

8

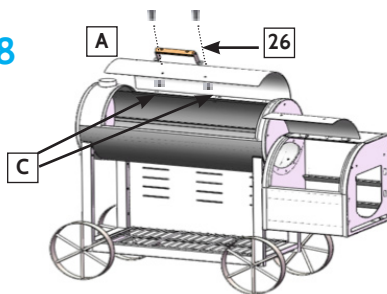

Den Griff für die Haupttröhre mit 2 Schrauben (A) und 2 Schrauben (C) anbringen.

9

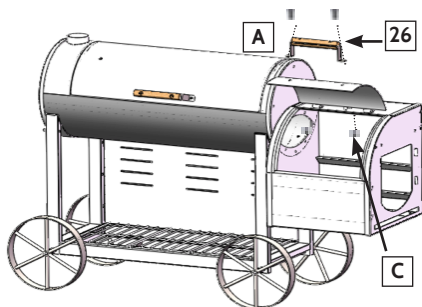

Den Griff der Brennkammer mit 2 Schrauben (A) und 2 Schrauben (C) anbringen.

10

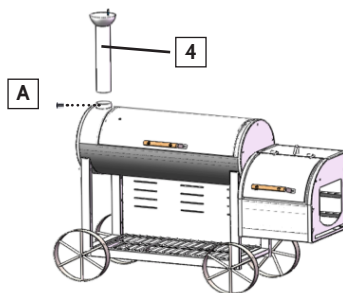

Den Kaminabzug mit einer Schraube (A) befestigen.

11

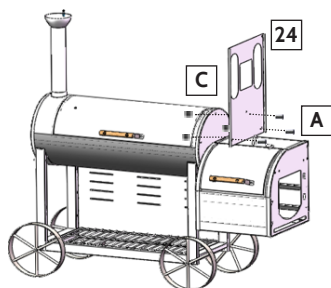

Die Zierplatte der Brennkammer mit 3 Schrauben (A) und 3 Schrauben (C) anbringen.

12

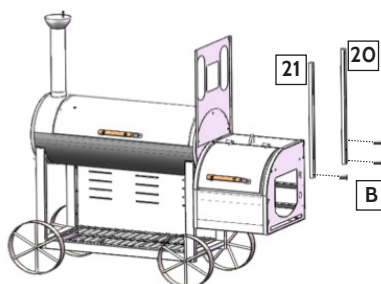

Die Stützen der Zierplatte mit 3 Schrauben (B) anbringen.

13

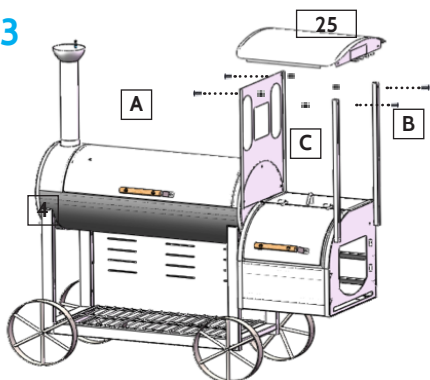

Das Dach mit 2 Schrauben (A), 2 Schrauben (B) und 4 Schrauben (C) anbringen.

14

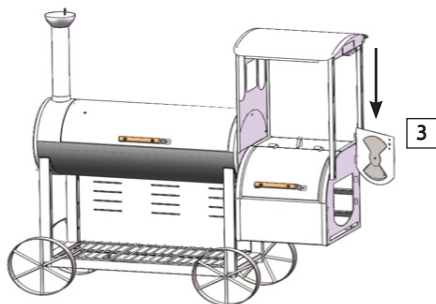

Kohletür der Brennkammer einschieben.

15

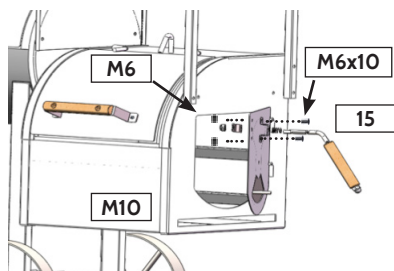

Den Griff der Brennkammer montieren. Schrauben Sie zuerst die vormontierten M6x10 Schrauben mit den Muttern ab und schrauben Sie wieder alles wie in dem Bild oben zusammen.

16

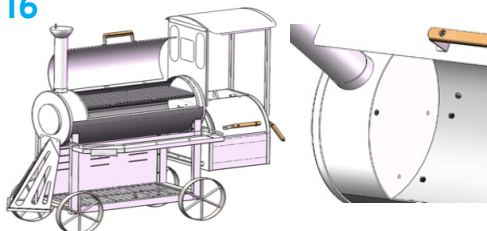

Die Zierplatte mit 2 Schrauben (A) und 2 Schrauben (C) montieren.

17

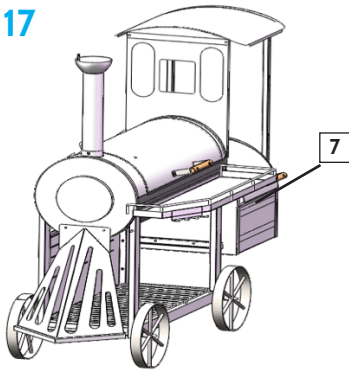

Die vordere Ablage montieren.

18

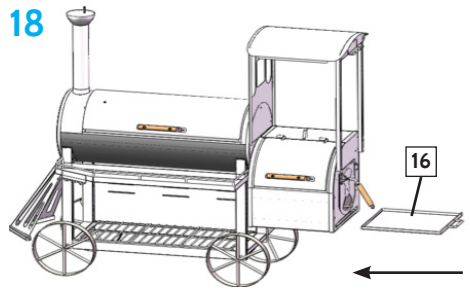

Das Ascheblech in die Brennkammer schieben.

19

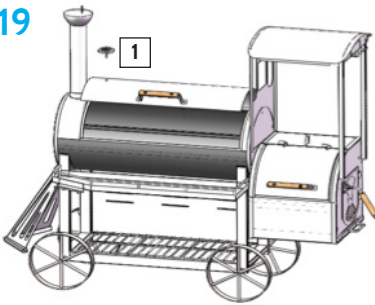

Das Thermometer einsetzen.

20

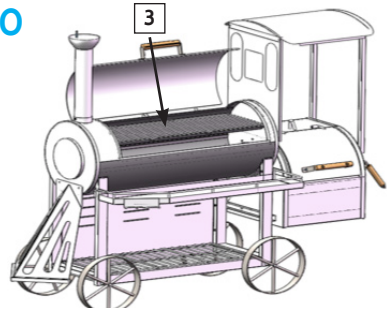

Den Rost für die Räucherammer und die Kohlenpfanne einsetzen

21

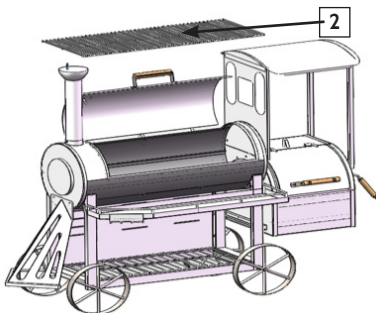

Die 3 Teile des Rosts für die Räucherammer einsetzen.

22

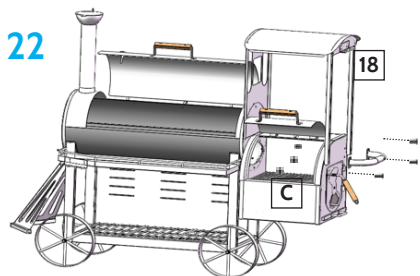

Die Seitengriffe mit 4 Schrauben (A) und 4 Schrauben (C) montieren.

23

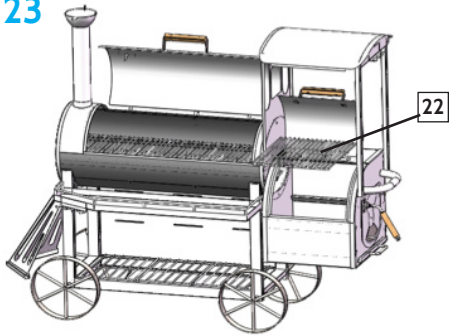

Setzen Sie den Kohlerost der Brennkammer ein.

24

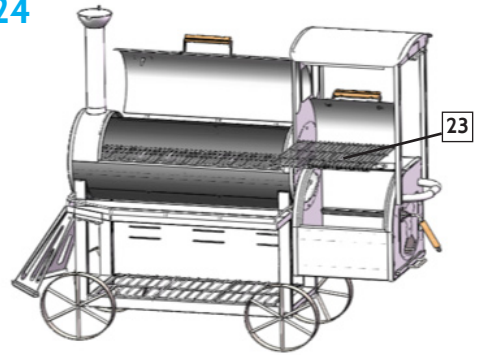

Setzen Sie den zweiteiligen Grillrost zusammen.



Herzlichen Glückwunsch. Der Aufbau ist fertig.

Hersteller: Chal-Tec GmbH, Wallstr. 16, 10179 Berlin







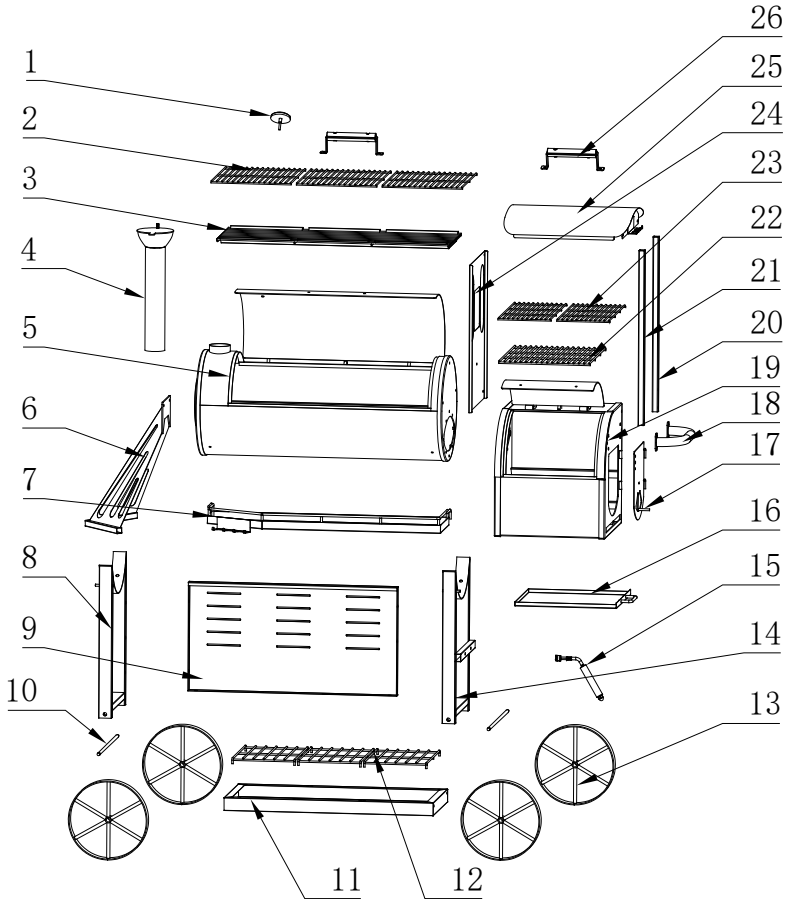









Dear Customer,









Congratulations on purchasing this equipment. Please read this manual carefully and take care of the following hints on installation and use to avoid technical damages. Any failure caused by ignoring the items and cautions mentioned in the operation and installation instructions are not covered by our warranty and any liability.

Equipment Overview



Parts List

Nr.	Part	Qty	Illustration
1	Thermometer	1	
2	Main body Grid	3	
3	Main body charcoal grid and charcoal pan	2	
4	Chimney	1	
5	Main body	1	
6	Decorating plate	2	
7	Front shelf	2	
8	Left leg part	2	
9	Back plate part	1	
10	Axle	2	
11	Bottom plate	1	
12	Bottom rack	3	
13	Wheel	4	
14	Right leg part	2	
15	Charcoal door handle	1	
16	Firebox ash tray	2	
17	Firebox charcoal door	2	

Nr.	Part	Qty	Illustration
18	Side handle	1	
19	Firebox	1	
20	Firebox decorating plate back support	1	
21	Firebox decorating plate front support	1	
22	Firebox charcoal grid	1	
23	Firebox grid	2	
24	Firebox decorating plate	1	
25	Firebox top	1	
26	Lid handle	2	

Screws

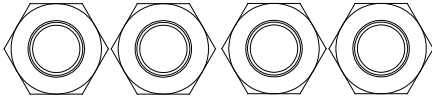

M10 4PCS

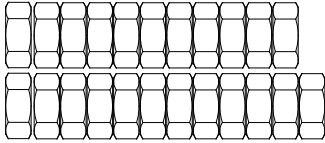

M6 23PCS

M6*35 5PCS

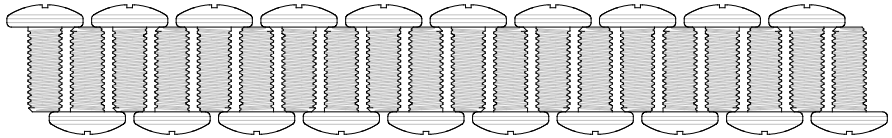
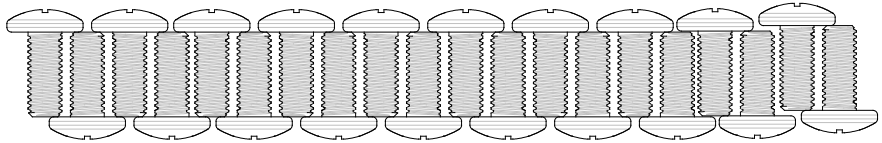
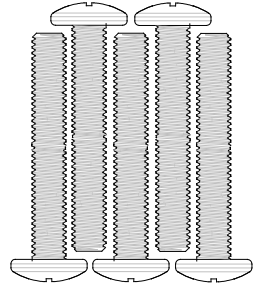

M6*15 40PCS

A	M6x15 screw	40
B	M6x35 screw	5
C	M6 nut	23
D	M10 lock nut	4

Assembly

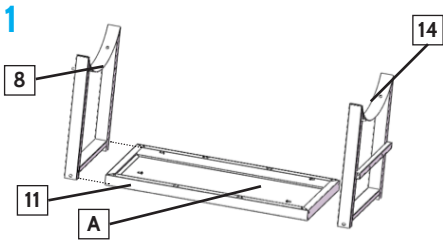

Assemble the bottom plate, left leg part and right leg part with 4pcs A.

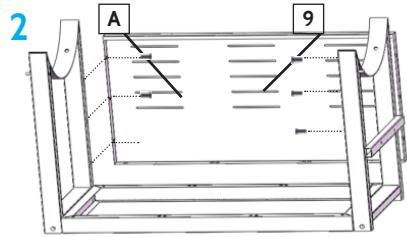

Assemble the back plate part with 6pcs A.

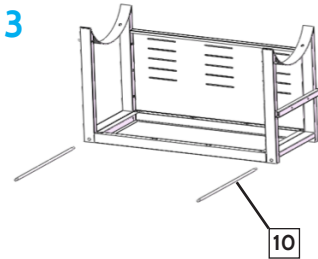

Assemble the Axels.

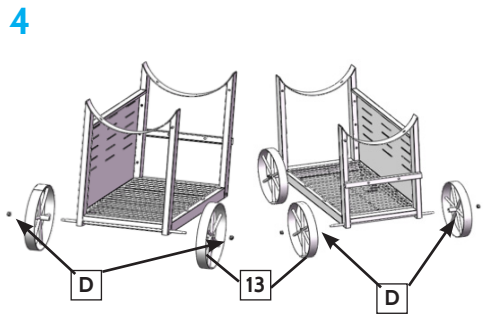

Assemble the wheels with 4PCS D.

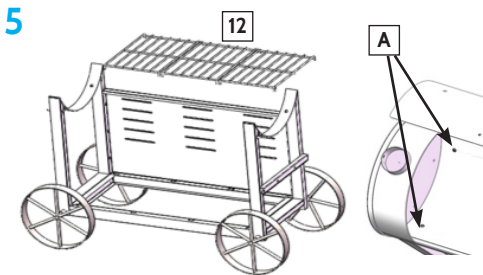

Assemble 3PCS bottom rack.

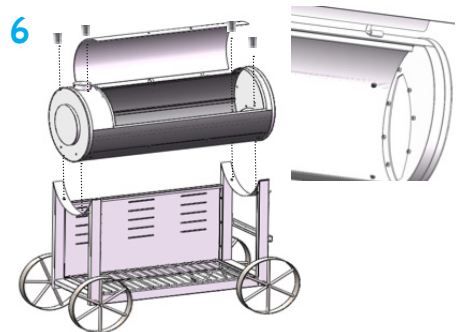

Assemble the main body (the lidis already assembled) with 4pcs A and 4pcs C.

7

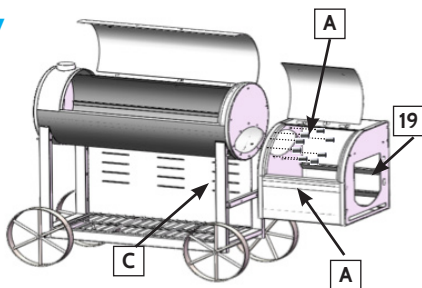

Assemble the firebox with 10pcs A and 2pcs C. Assemble the outer 2pcs screws, but do not tighten the screws until the firebox is loaded.

8

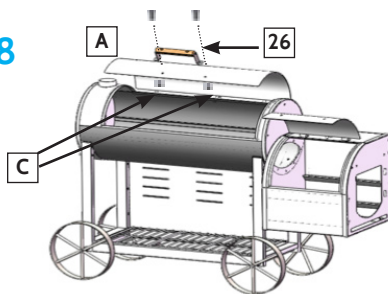

Assemble the Main body handle with 2pcs A and 2pcs C.

9

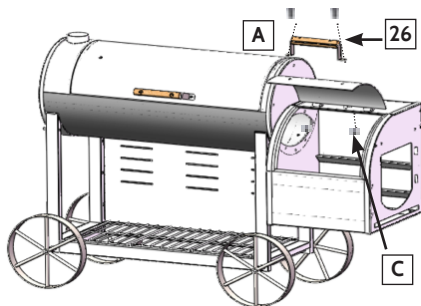

Assemble the firebox handle with 2PCS A and 2PCS C.

10

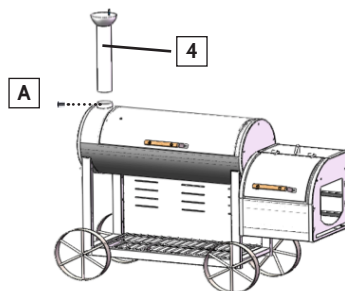

Assemble the chimney with 1PC A.

11

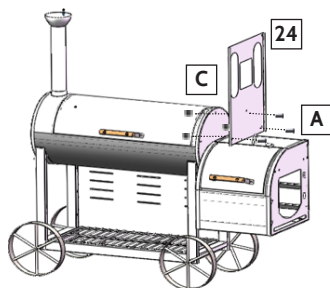

Assemble the firebox decorating plate with 3PCS A and 3PCS C.

12

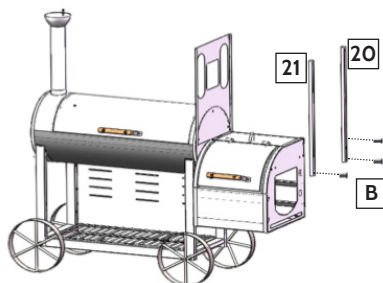

Assemble the decorating plate front & back support with 3PCS B.

13

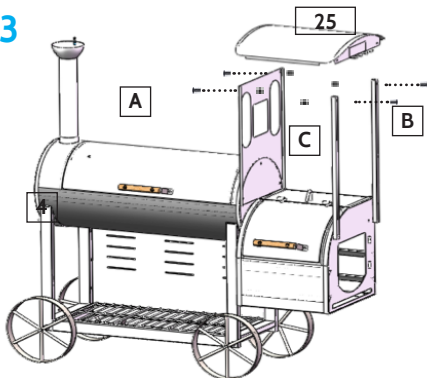

Assemble the firebox top with 2PCS A·2PCS B and 4PCS C.

14

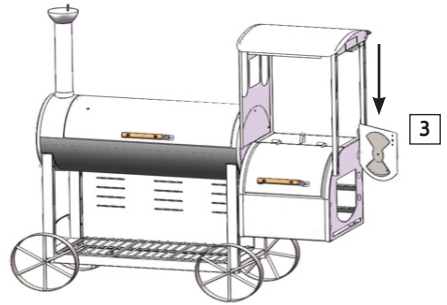

Assemble the firebox charcoal door.

15

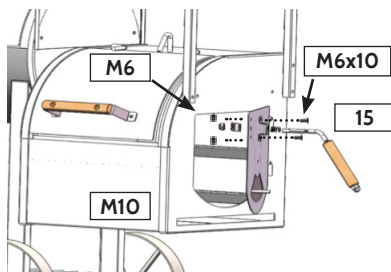

Assemble the firebox charcoal handle, first take down the 2pcs M6*10 screws, 2pcs M6 nuts, and M10 lock nuts, and then re-assemble as below picture..

16

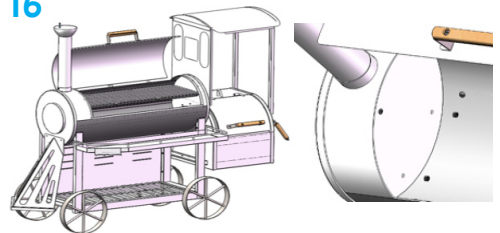

Assemble the decorating plate with 2PCS A and 2PCS C.

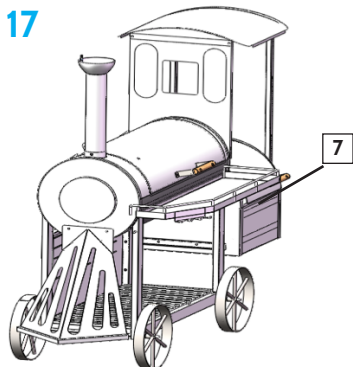

Assemble the front shelf.

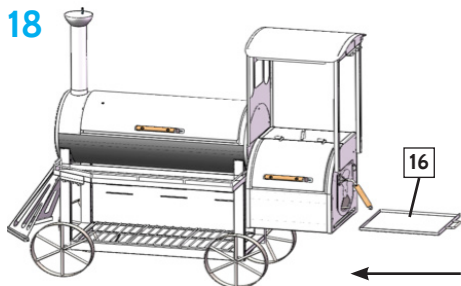

Assemble the firebox ash tray to the firebox.

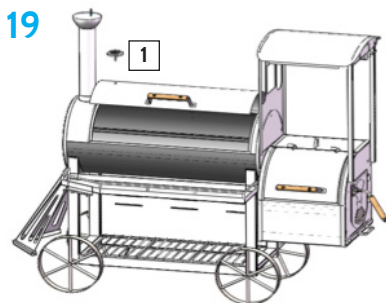

Assemble the thermometer.

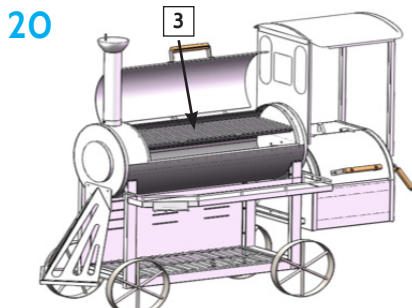

Assemble the main body charcoal grid and charcoal pan.

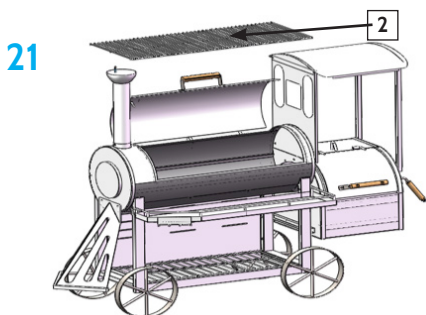

Assemble the 3PCS main body grid.

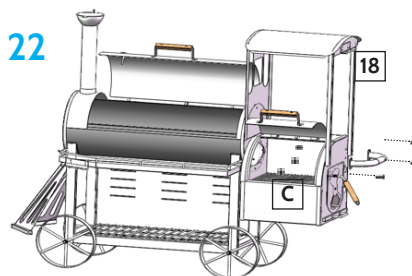

Assemble the side handle with 4PCS A and 4PCS C.

23

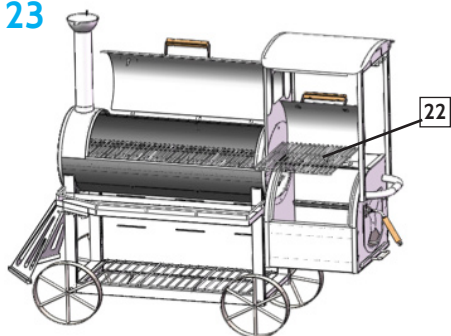

Assemble the firebox charcoal grid.

24



Assemble the 2pcs firebox grid.



Congratulations. The assembly is finished.

Producer: Chal-Tec GmbH, Wallstr. 16, 10179 Berlin

Chère cliente, cher client,





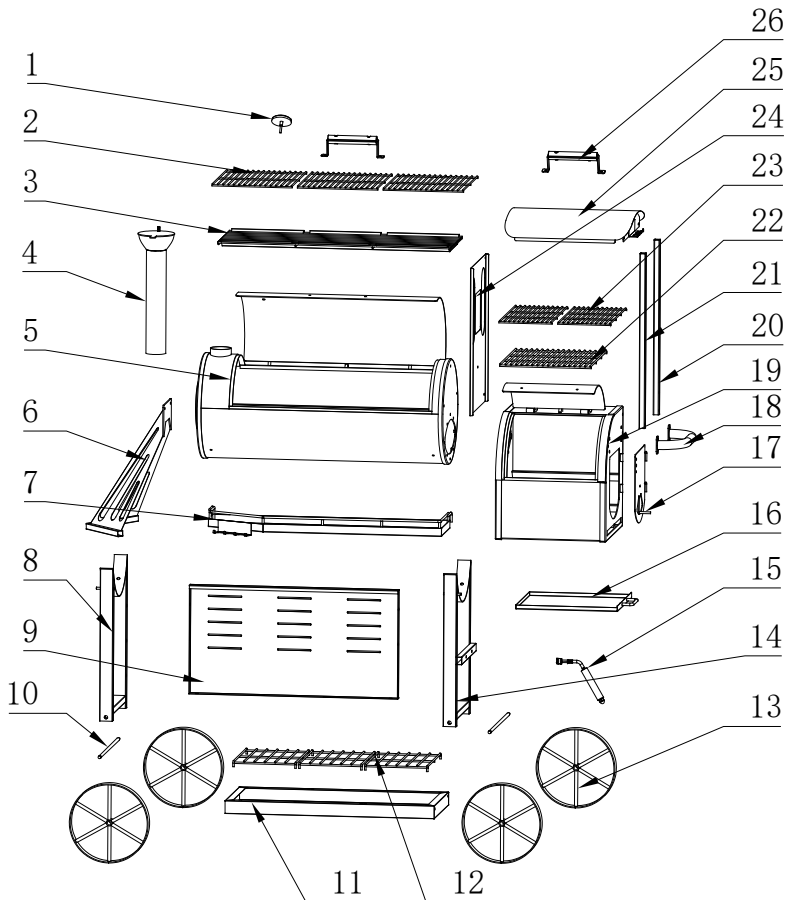





Toutes nos félicitations pour l'acquisition de ce nouvel appareil. Veuillez lire attentivement et respecter les instructions de ce mode d'emploi afin d'éviter d'éventuels dommages. Nous ne saurions être tenus pour responsables des dommages dus au non-respect des consignes et à la mauvaise utilisation de l'appareil.

Aperçu de l'appareil



Liste des pièces détachées

N°	Pièce	Qté	Image
1	Thermomètre	1	
2	Grand gril	3	
3	Plaque et gril à charbon	2	
4	Conduit de cheminée	1	
5	Chambre de fumaison	1	
6	Pare-chocs décoratif	2	
7	Plateau avant	2	
8	Pied gauche	2	
9	Partie de la plaque arrière	1	
10	Essieu	2	
11	Plaque du bas	1	
12	Étagère du bas	3	
13	Roue	4	
14	Partie droite du pied	2	
15	Poignée de fermeture	1	
16	Bac de cendres pour la chambre de combustion	2	

N°	Pièce	Qté	Image
17	Trappe à charbon pour la chambre de combustion	2	
18	Poignée latérale	1	
19	Pied arrière droit	1	
20	Baguette de soutien de la plaque avant	1	
21	Baguette de soutien de la plaque avant	1	
22	Gril à charbon pour la chambre de combustion	1	
23	Gril pour la chambre de combustion	2	
24	Plaque décorative de la chambre de combustion	1	
25	Dessus de la chambre de combustion	1	
26	Poignée du couvercle	2	

Vis

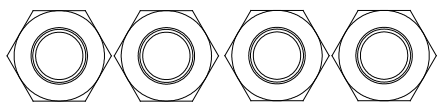

M10 4 Unités

M6*35 5 Unités

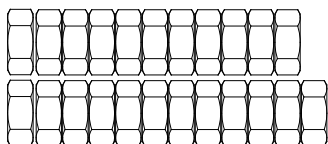
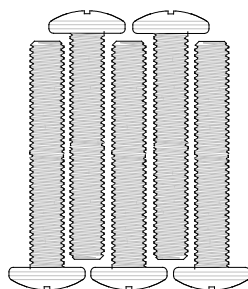

M6 23 Unités

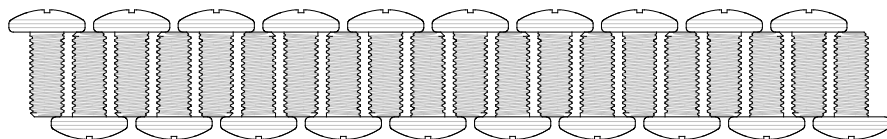
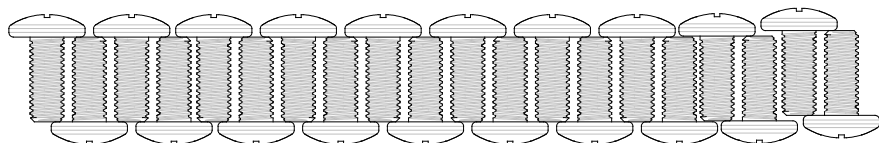

M6*15 40 Unités

A	Vis M6x15	40
B	Vis M6x35	5
C	Contre-écrous M6	23
D	Écrous M10	4

Montage

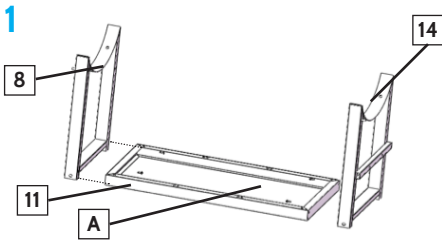

Monter la structure du fond avec le pied gauche et droit à l'aide de vis (A).

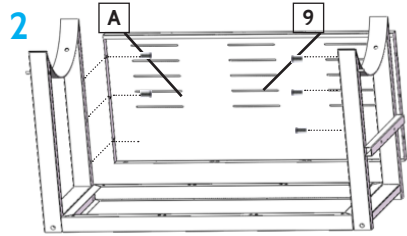

Monter la plaque arrière avec 6 vis (A)

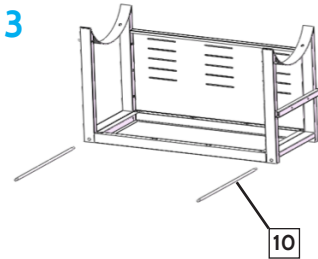

Monter les essieux.

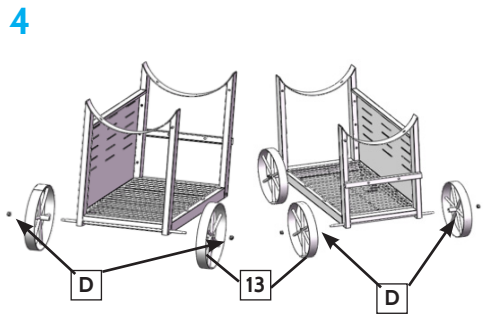

Monter les roues avec 4 écrous (D)

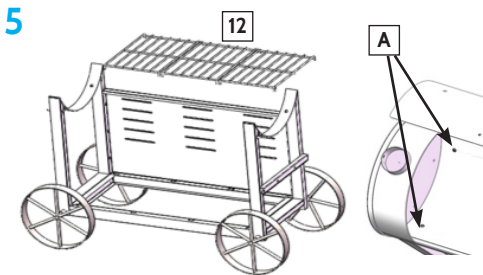

Fixer l'étagère du bas en trois parties.

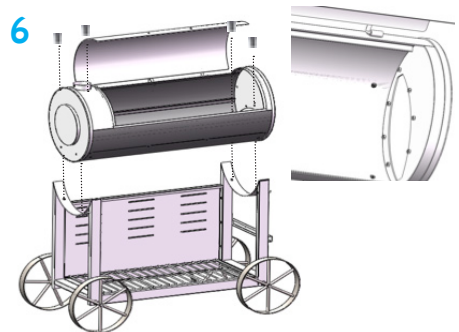

Assembler le cylindre d'enfumage avec 4 vis (A) et 4 contre-écrous (C). Les couvercles sont déjà pré-montés.

7

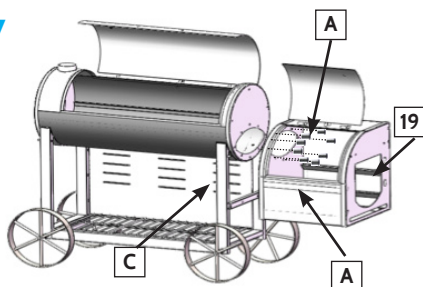

Fixer la chambre de combustion avec 10 vis (A) et 2 contre-écrous (C). Monter les deux vis extérieures.

8

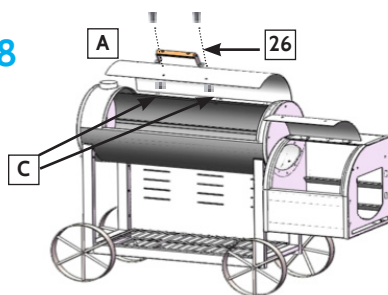

Monter la poignée du tube principal avec 2 vis (A) et 2 contre-écrous (C).

9

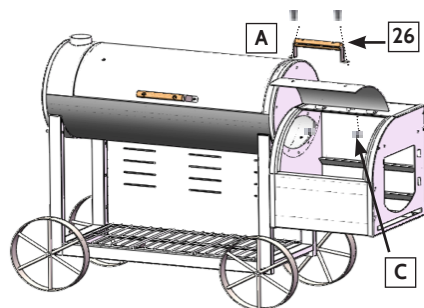

Monter la poignée de la chambre de combustion avec 2 vis (A) et 2 contre-écrous (C).

10

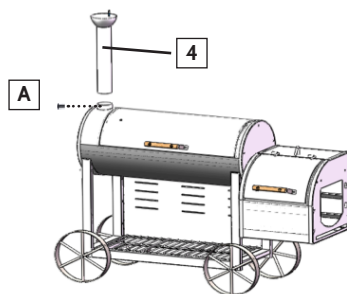

Monter le conduit de cheminée et le fixer avec une vis (A).

11

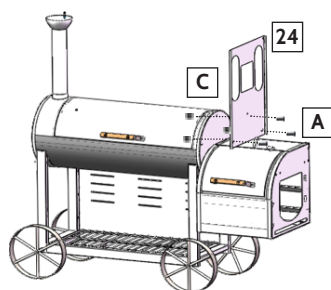

Fixer la plaque décorative de la chambre de combustion avec 3 vis (A) et 3 contre-écrous (C).

12

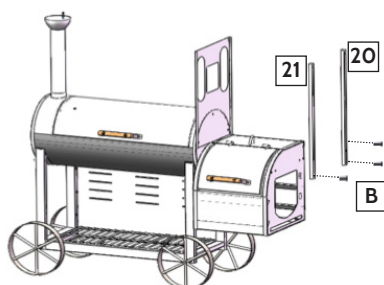

Fixer la plaque décorative de la chambre de combustion avec 3 vis (A) et 3 contre-écrous (C).

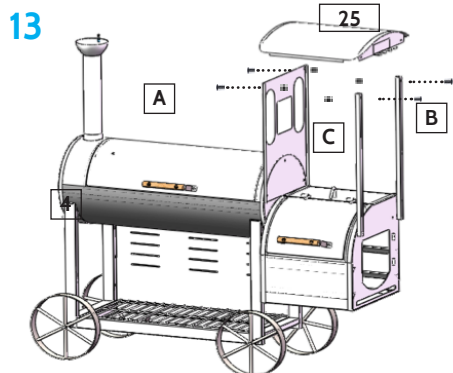

Monter le toit avec 2 vis (A), 2 vis (B) et 4 vis (C).

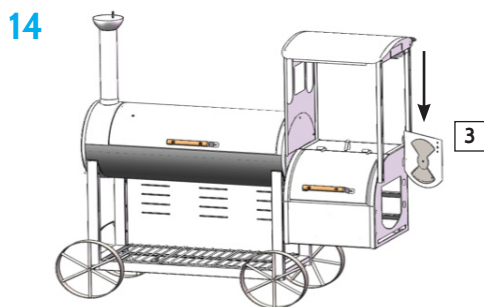

Faire coulisser la porte à charbon de la chambre de combustion.

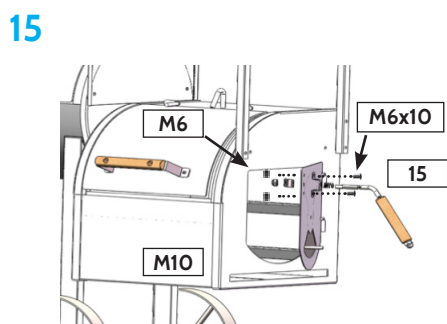

Monter la poignée de la chambre de combustion. Dévisser d'abord les vis M6x10 pré-montées puis remonter le tout comme illustré ci-dessus.

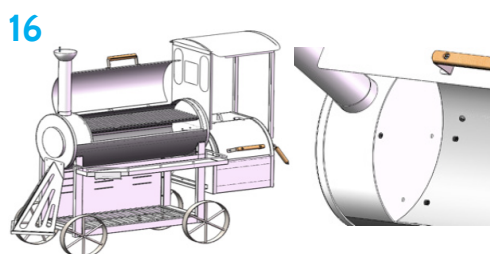

Fixer la plaque décorative avec 2 vis (A) et 2 contre-écrous (C).

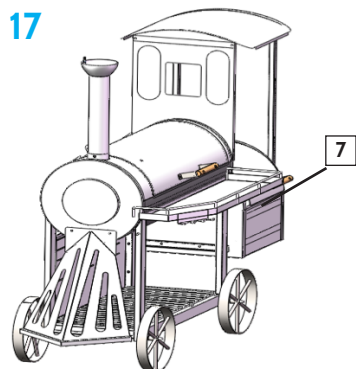

Monter le plateau avant.

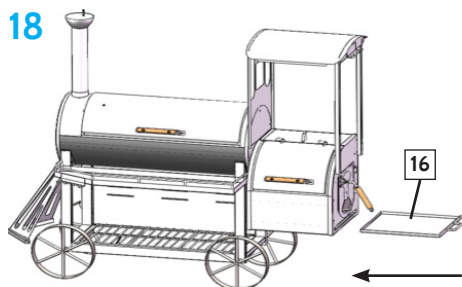

Faire glisser le bac de cendres dans la chambre de combustion.

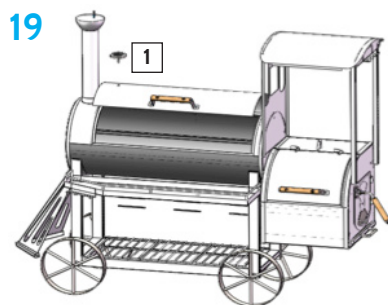

Installer le thermomètre.

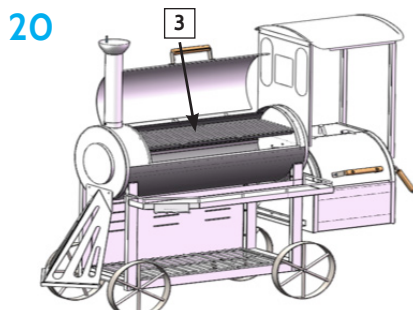

Installer le grill de la chambre d'enfumage ainsi que le grill à charbon.

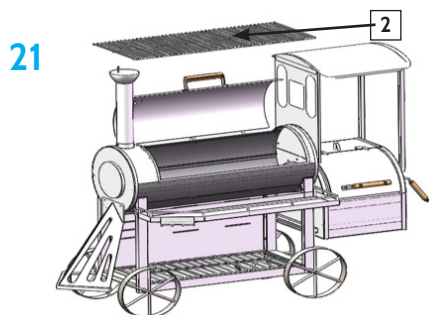

Installer les 3 parties du grill dans la chambre de combustion.

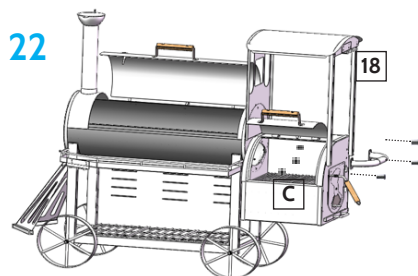

Monter les poignées latérales avec 4 vis (A) et 4 contre-écrous (C).

23

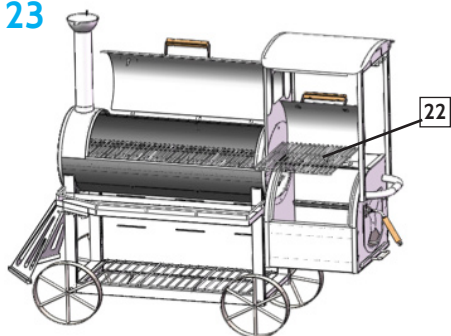

Installer le grill à charbon dans la chambre de combustion.

24



Assembler les deux parties du grill.



Bravo. Le montage est terminé.

Fabricant : Chal-Tec GmbH, Wallstr. 16, 10179 Berlin , Allemagne







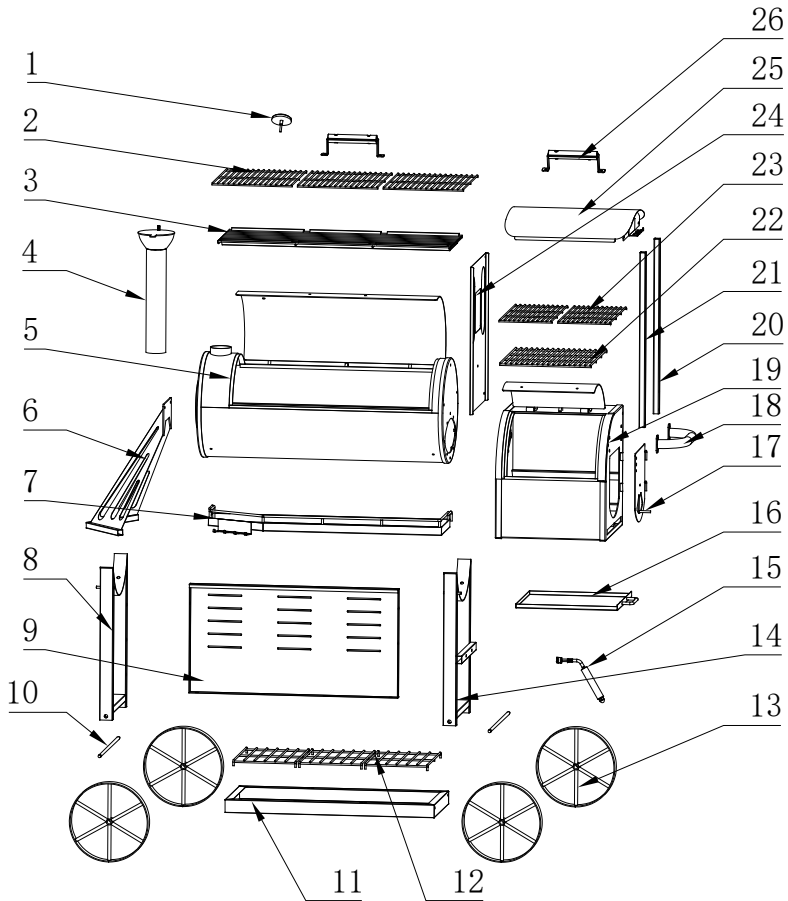



Gentile cliente,

La ringraziamo per aver acquistato il nostro dispositivo. La preghiamo di leggere attentamente le seguenti istruzioni e di seguirle per evitare eventuali danni. Non ci assumiamo alcuna responsabilità per danni derivati da una mancata osservazione delle avvertenze di sicurezza e da un uso improprio del dispositivo.

Descrizione del prodotto



Nr.	Componente	Quantità	Figura
1	Termometro	1	
2	Griglia per l'unità principale	3	
3	Griglia a carbone per l'unità principale e padella a carbone	2	
4	Scarico camino	1	
5	Unità principale	1	
6	Piastra decorativa	2	
7	Ripiano frontale	2	
8	Gamba sinistra	2	
9	Piastra posteriore	1	
10	Asse	2	
11	Piastra inferiore	1	
12	Ripiano inferiore	3	
13	Ruota	4	
14	Parte destra della gamba	2	
15	Impugnatura sportello	1	

Nr.	Componente	Quantità	Figura
16	Raccogliatore cenere per camera di combustione	2	
17	Sportello camera di combustione	2	
18	Impugnatura laterale	1	
19	Camera di combustione	1	
20	Listello decorativo piastra posteriore	1	
21	Listello decorativo piastra frontale	1	
22	Griglia a carbone per la camera di combustione	1	
23	Griglia per la camera di combustione	2	
24	Piastra decorativa camera di combustione	1	
25	Parte superiore della camera di combustione	1	
26	Impugnatura coperchio	2	

Viti

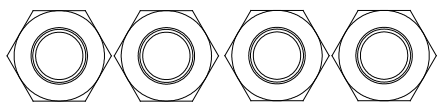

M10 4 pezzi

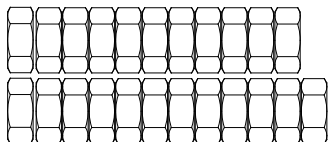

M6 23 pezzi

M6*35 5 pezzi

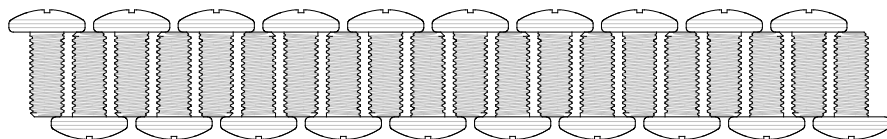
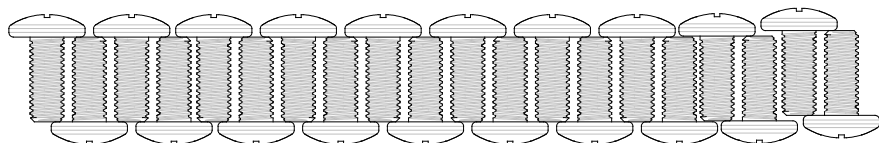
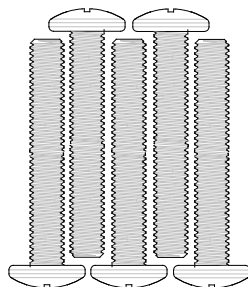

M6*15 40 pezzi

A	Viti M6x15	40
B	Viti M6x35	5
C	Controdadi M6	23
D	Dadi M10	4

Montaggio

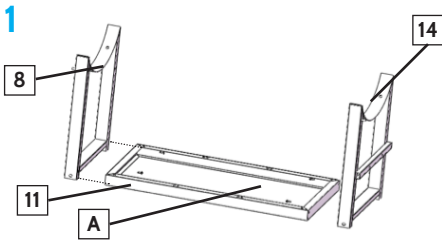

Assemblare la piastra inferiore, la gamba sinistra e la gamba destra utilizzando le viti (A).

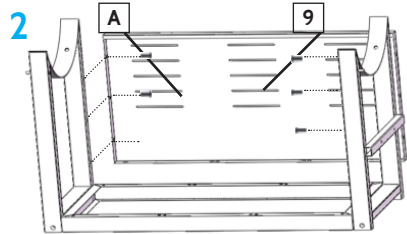

Montare la piastra posteriore utilizzando 6 viti (A).

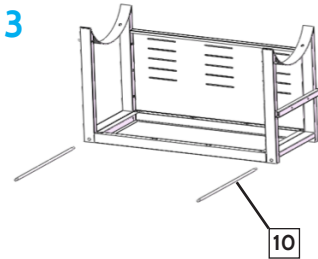

Assemblare gli assi.

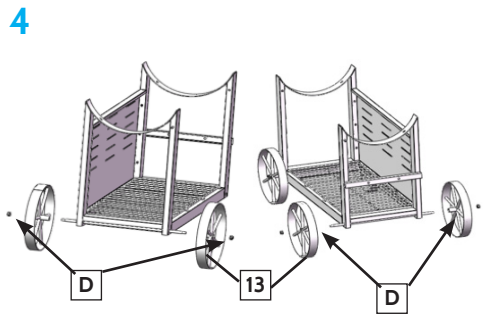

Montare le ruote utilizzando 4 dadi (D).

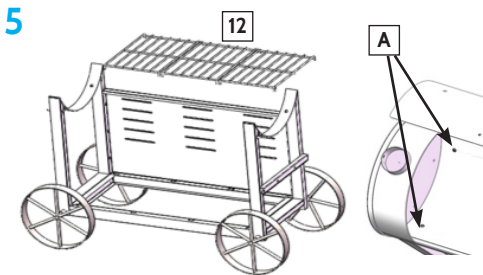

Fissare il ripiano per il pavimento composto da tre parti.

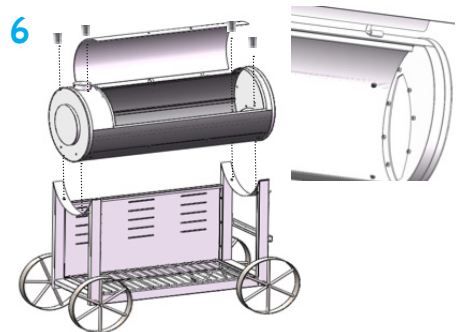

Assemblare l'unità principale utilizzando 4 viti (A) e 4 viti (C). I coperchi sono già montati.

7

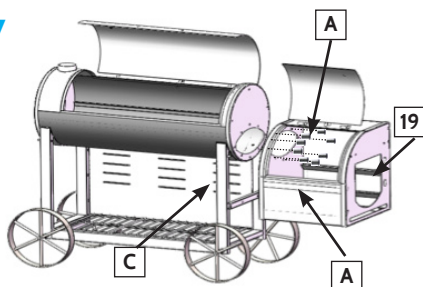

Fissare la camera di combustione con 10 viti (A) e 2 viti (C). Assemblare entrambe le viti esterne. Serrare le viti solo dopo aver montato la camera di combustione.

8

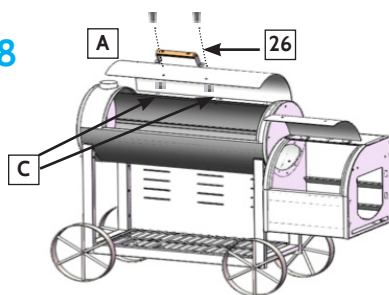

Assemblare l'impugnatura dei tubi principali utilizzando 2 viti (A) e 2 viti (C).

9

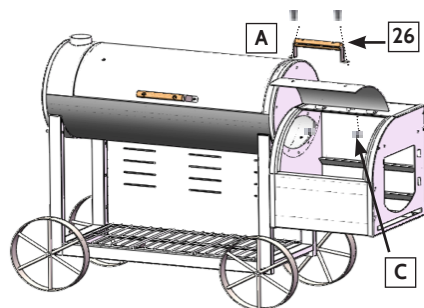

Assemblare l'impugnatura della camera di combustione utilizzando 2 viti (A) e 2 viti (C).

10

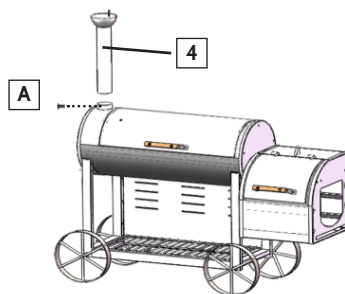

Fissare lo scarico del camino utilizzando una vite (A).

11

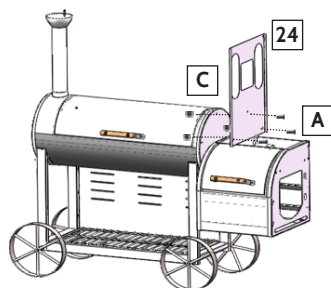

Assemblare la piastra decorativa utilizzando 3 viti (A) e 3 viti (C).

12

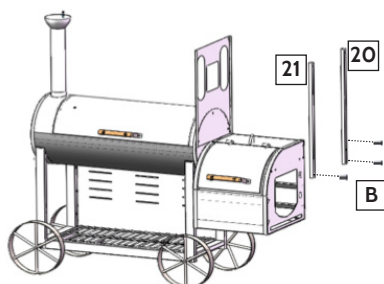

Assemblare la piastra decorativa utilizzando 3 viti (B).

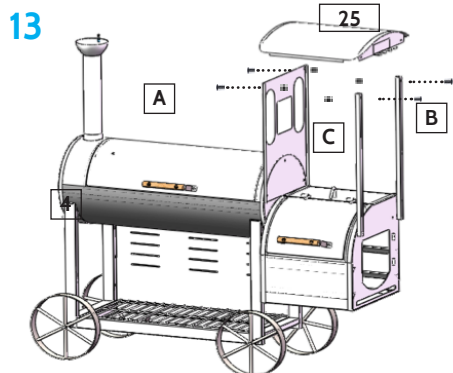

Assemblare il tetto utilizzando 2 viti (A), 2 viti (B) e 4 viti (C).

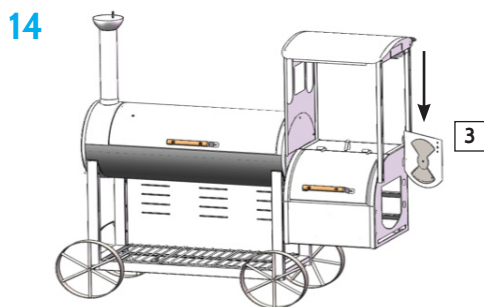

Inserire lo sportello della camera di combustione.

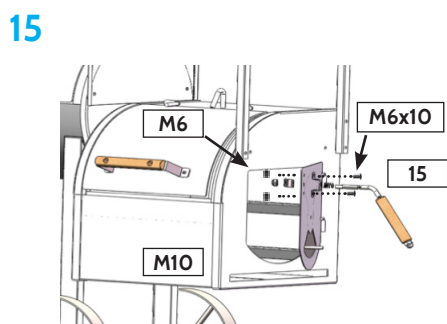

Montare l'impugnatura della camera di combustione. Svitare per prima cosa le viti premontate M6x10 e i dadi e assemblare tutto di nuovo come rappresentato nella figura.

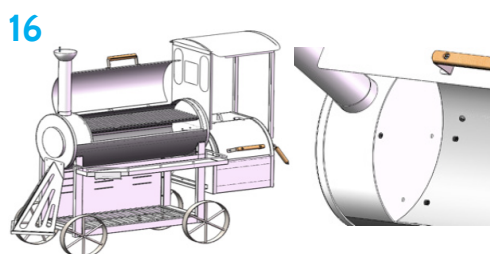

Montare la piastra decorativa utilizzando 2 viti (A) e 2 viti (C).

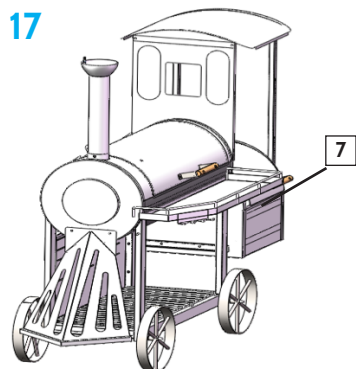

Montare il ripiano frontale.

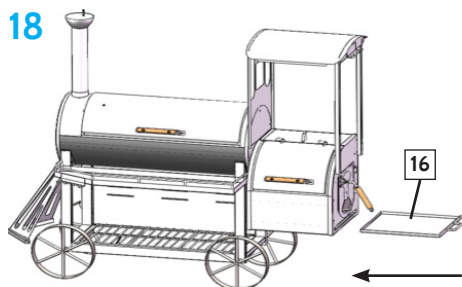

Inserire il contenitore per la cenere nella camera di combustione.

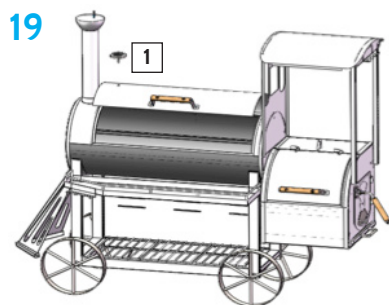

Inserire il termometro.

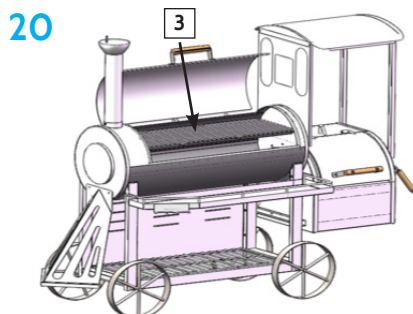

Inserire la griglia a carbone per l'unità principale e la padella a carbone.

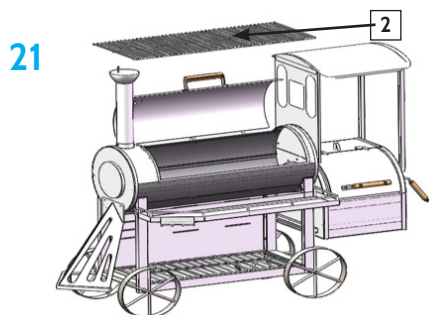

Inserire la griglia per l'unità principale composta da tre parti.

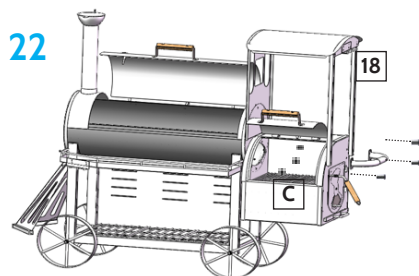

Montare le impugnature laterali utilizzando 4 viti (A) e 4 viti (C).

23

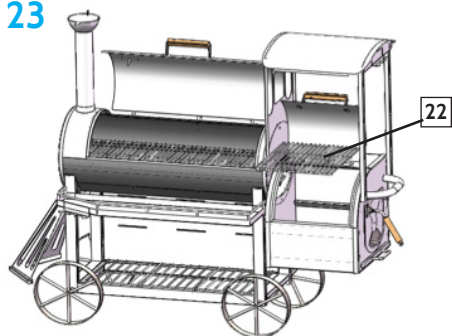

Inserire la griglia a carbone per la camera di combustione.

24



Assemblare la griglia per la camera di combustione composta da due parti.



Congratulazioni! Il montaggio è terminato.

Produttore: Chal-Tec GmbH, Wallstr. 16, 10179 Berlino

Estimado cliente,





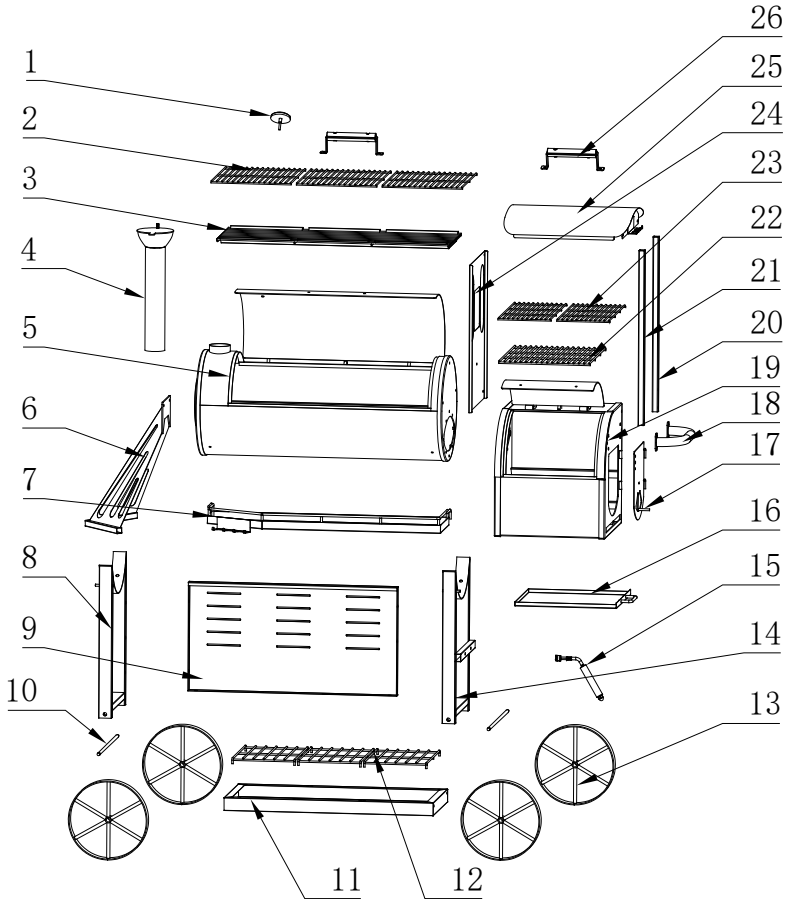





Le felicitamos por la adquisición de este producto. Lea atentamente el siguiente manual y siga cuidadosamente las instrucciones de uso con el fin de evitar posibles daños. La empresa no se responsabiliza de los daños ocasionados por un uso indebido del producto o por haber desatendido las indicaciones de seguridad.

Descripción del aparato



Lista de piezas

N.º	Pieza	Canti- dad	Imagen
1	Termómetro	1	
2	Parrilla grande	3	
3	Recipiente para el carbón y parrilla para el carbón	2	
4	Tiro de la chimenea	1	
5	Cámara de combustión	1	
6	Parte delantera decorativa	2	
7	Balda delantera	2	
8	Pata izquierda	2	
9	Pieza de la placa trasera	1	
10	Eje	2	
11	Placa inferior	1	
12	Rejilla inferior	3	
13	Rueda	4	
14	Parte derecha de la pata	2	
15	Asa de la cámara de combustión	1	

N.º	Pieza	Canti- dad	Imagen
16	Bandeja para la ceniza de la cámara de combustión	2	
17	Puerta para el carbón de la cámara de combustión	2	
18	Asa lateral	1	
19	Pata trasera derecha	1	
20	Listón decorativo para la sujeción de la placa trasera	1	
21	Listón decorativo para la sujeción de la placa delantera	1	
22	Rejilla para el carbón de la cámara de combustión	1	
23	Parrilla de la cámara de combustión	2	
24	Placa decorativa de la cámara de combustión	1	
25	Parte superior de la cámara de combustión	1	
26	Asa de la tapa	2	

Tornillos

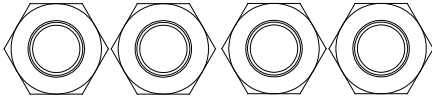

M10 4 uds

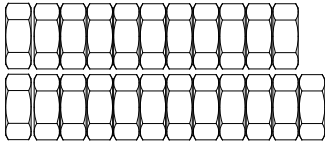

M6 23 uds

M6*35 5 uds

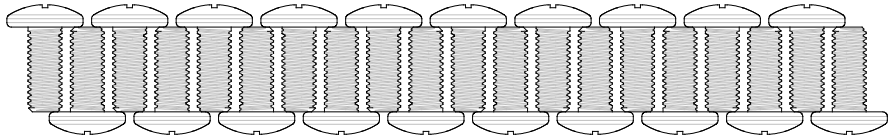
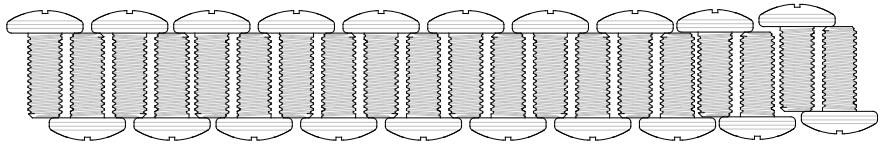
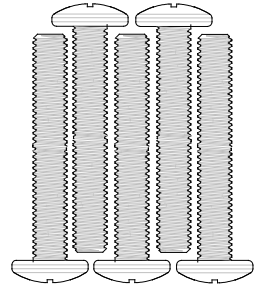

M6*15 40 uds

A	Tornillos M6x15	40
B	Tornillos M6x35	5
C	Contratuercas M6	23
D	Tuercas M10	4

Montaje

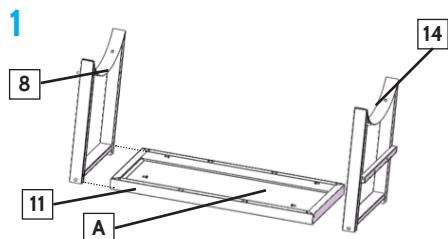

Coloque la placa inferior, la pata izquierda y la derecha y atornillelas con los tornillos (A).

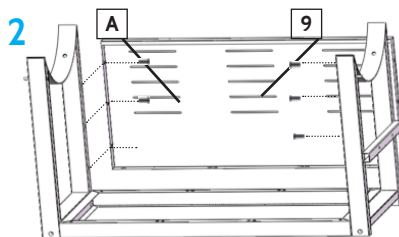

Monte la placa trasera con los 6 tornillos.

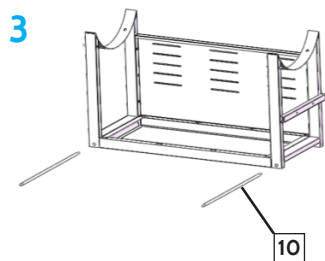

Monte los ejes

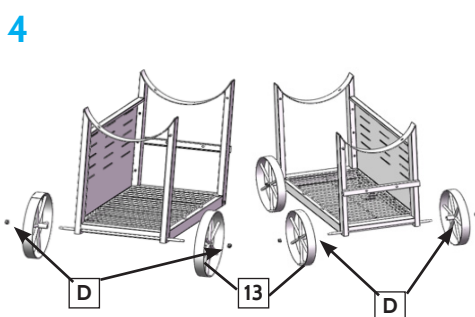

Monte las ruedas utilizando 4 tuercas (D).

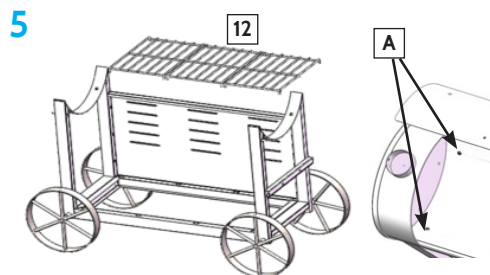

Fije la balda inferior compuesta por tres piezas.

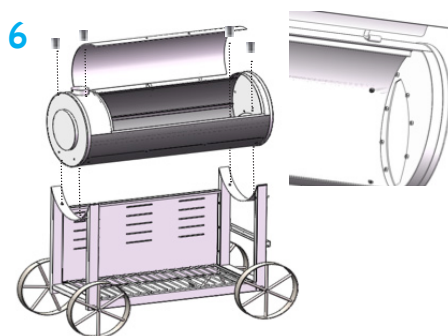

Coloque el cilindro de la estructura principal con 4 tornillos (A) y 4 tornillos (C). La tapa ya está montada.

7

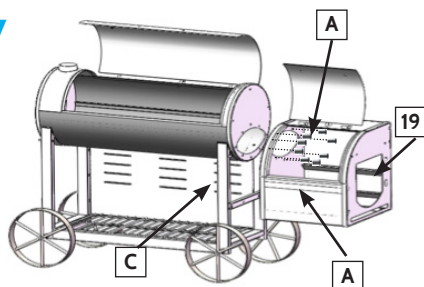

Fije la cámara de combustión con 10 tornillos (A) y 2 tornillos (C). Monte ambos tornillos exteriores. Apriete los tornillos tras colocar la cámara de combustión.

8

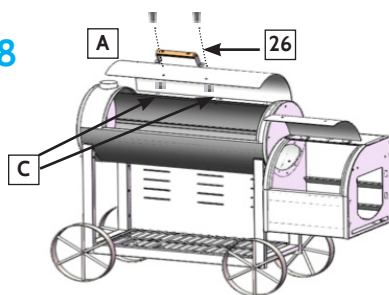

Monte el asa de la estructura principal con 2 tornillos (A) y 2 tornillos (C).

9

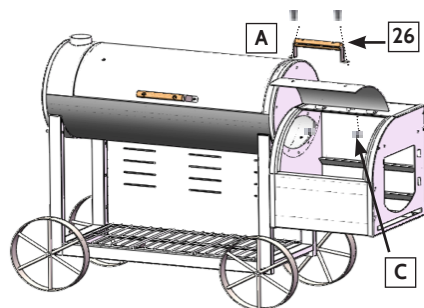

Monte el asa de la cámara de combustión con 2 tornillos (A) y 2 tornillos (C).

10

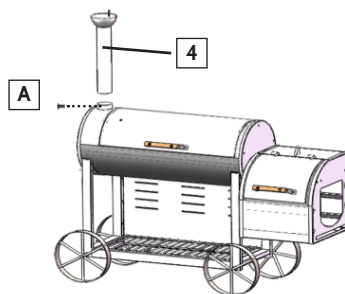

Fije el tiro de la chimenea con un tornillo.

11

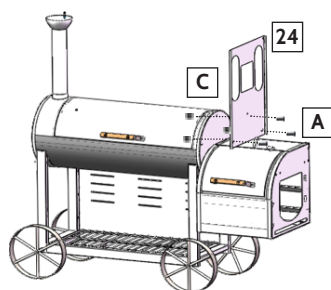

Monte placa decorativa de la cámara de combustión con 3 tornillos (A) y 3 tornillos (C).

12

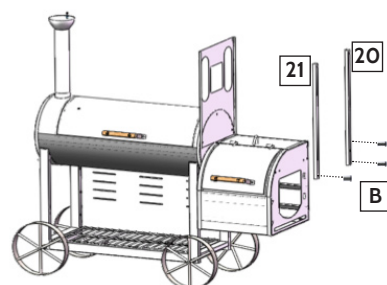

Monte los soportes de la placa decorativa con 3 tornillos (B).

13

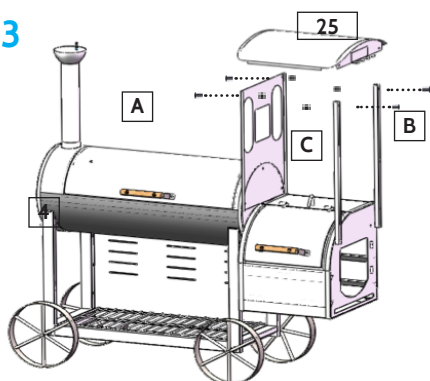

Monte la parte superior de la cámara de combustión con 2 tornillos (A), 2 tornillos (B) y 4 tornillos (C).

14

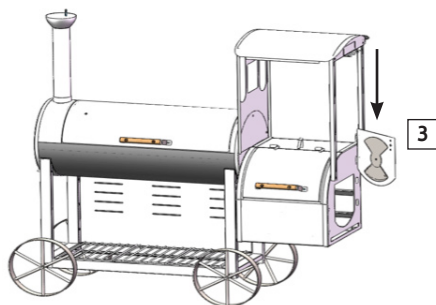

Instale la puerta para el carbón de la cámara de combustión.

15

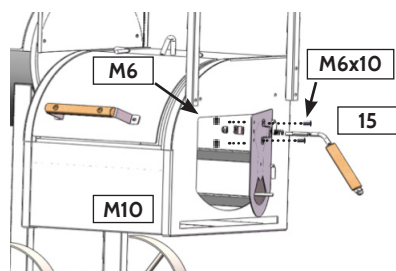

Monte el asa de la cámara de combustión. Afloje primero los tornillos M6x10 premontados con las tuercas y vuelva a atornillar todo como se muestra en la imagen.

16

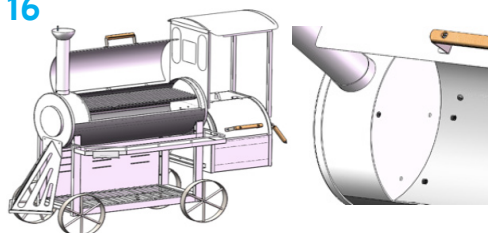

Monte la placa decorativa con 2 tornillos (A) y 2 tornillos (C).

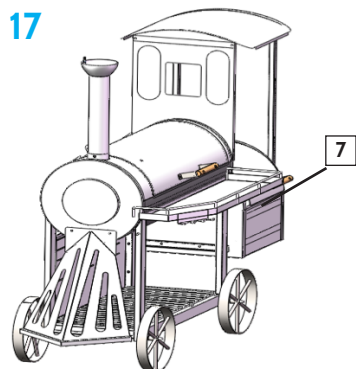

Monte la balda delantera.

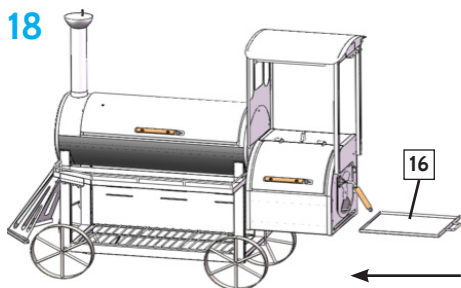

Deslice la bandeja para las cenizas en el interior de la cámara de combustión.

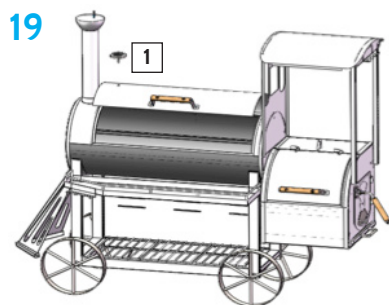

Coloque el termómetro.

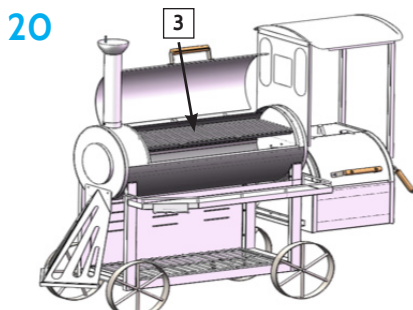

Coloque la rejilla de la cámara de combustión y el recipiente para el carbón.

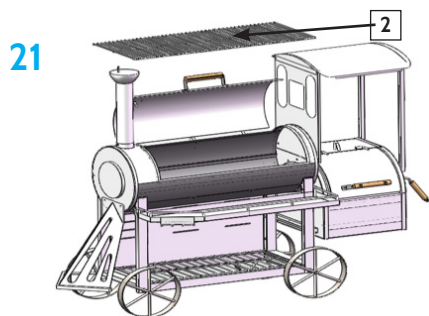

Coloque las tres partes de la rejilla para la cámara de combustión.

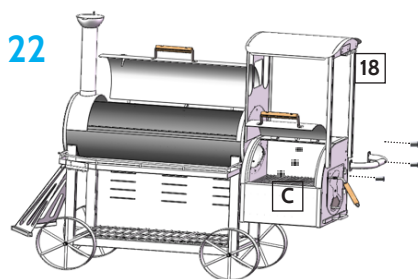

Monte el asa lateral con 4 tornillos (A) y 4 tornillos (C).

23

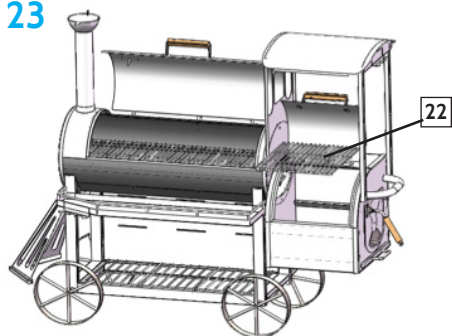

Coloque la rejilla para el carbón en la cámara de combustión.

24



Monte las dos piezas de la parrilla.



Enhorabuena. Ha terminado con el montaje.

Fabricante: Chal-Tec GmbH, Wallstraße 16, 10179 Berlín (Alemania).