

10030605 10030606 10030607

The Green Supreme

The Orange Supreme

The Blue Supreme

Bollerwagen

Handcart

Carrito

Chariot de transport

Carretto

Sehr geehrter Kunde,

wir gratulieren Ihnen zum Erwerb Ihres Gerätes. Lesen Sie die folgenden Hinweise sorgfältig durch und befolgen Sie diese, um möglichen Schäden vorzubeugen. Für Schäden, die durch Missachtung der Hinweise und unsachgemäßen Gebrauch entstehen, übernehmen wir keine Haftung. Scannen Sie den folgenden QR-Code, um Zugriff auf die aktuellste Bedienungsanleitung und weitere Informationen rund um das Produkt zu erhalten.



INHALTSVERZEICHNIS

Geräteübersicht 4
 Aufbau 5
 Dach-Aufbau 6
 Abbau 7
 Hersteller 7

English 9
Español 15
Français 21
Italiano 27

TECHNISCHE DATEN

Artikelnummer	10030605, 10030606, 10030607
Maße offen	76 x 51 x 20 cm
Maße gefaltet	51 x 163 x 50 cm
Gewicht	9,5 kg
Max. Belastbarkeit	68 kg
Lieferumfang	Faltwagen, Dach, Tasche, Kühltasche, Transporttasche, Bedienungsanleitung

GERÄTEÜBESICHT



AUFBAU



Öffnen Sie die Griffe der Transporttasche und entnehmen Sie den Faltwagen.



Ziehen Sie den Rahmen auseinander, bis der Wagen seine volle Ausdehnung hat.



Schieben Sie die Hinterräder auseinander, bis sie hörbar einrasten.

DACH-AUFBAU



Ziehen Sie die Stangen aus den Rahmen-Ecken, bis sie einrasten.



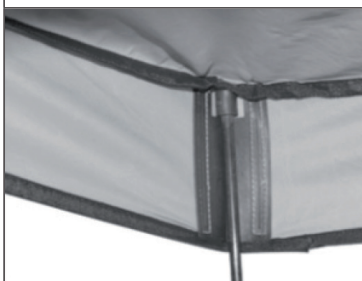

Ziehen Sie die Dach-Plane mit über die Endkappen der Stangen.



Ansicht der Innenseite: Die Eck-Verstärkungen sind innen.

ABBAU

	
<p>Schieben Sie zunächst die Hinterräder wieder in ihre Ausgangsposition.</p>	<p>Ziehen Sie den Riemen in der Mitte des Wagens, während Sie den Vordrädern die Drehung ermöglichen (nicht belasten).</p>
	
<p>Wenn Die Räder wieder in einer Reihe stehen, drücken Sie den Rahmen zusammen, drücken Sie die Griffe wieder mit den Klettverschlüssen. Nutzen Sie die Transporttasche für den geschützten Transport des Wagens.</p>	

HERSTELLER & IMPORTEUR (UK)

Hersteller:

Chal-Tec GmbH, Wallstraße 16, 10179 Berlin, Deutschland.

Importeur für Großbritannien:

Berlin Brands Group UK Ltd
 PO Box 1145
 Oxford, OX1 9UW
 United Kingdom

Dear Customer,

Congratulations on purchasing this device. Please read the following instructions carefully and follow them to prevent possible damages. We assume no liability for damage caused by disregard of the instructions and improper use. Scan the QR code to get access to the latest user manual and more product information.



CONTENT

Product Overview 10
Assembly 11
Roof set-up 12
Disassembly 13
Producer 13

TECHNICAL DATA

Item number	10030605, 10030606, 10030607
Dimensions open	76 x 51 x 20 cm
Dimensions folded	51 x 163 x 50 cm
Weight	9,5 kg
Max. load capacity	68 kg
Scope of delivery	Folding trolley, roof, bag, cooling bag, transport bag, operating instructions

PRODUCT OVERVIEW



ASSEMBLY



Open the handles of the transport bag and remove the folding trolley.



Pull the frame apart until the car is fully extended.



Slide the rear wheels apart until you hear them engage.

ROOF SET-UP



Pull the poles out of the frame corners until they click into place.





Pull the roof cover over the end caps of the poles.

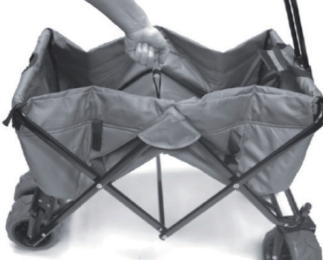

Inside view: The corner reinforcements are inside.

DISASSEMBLY

	
<p>First push the rear wheels back into their starting position.</p>	<p>Pull the belt in the middle of the trolley while allowing the front wheels to rotate (not load).</p>
	
<p>When the wheels are back in line, squeeze the frame together and secure the handles with the Velcro fasteners. Use the carrying bag for protected transport of the trolley.</p>	

MANUFACTURER & IMPORTER (UK)

Manufacturer:

Chal-Tec GmbH, Wallstrasse 16, 10179 Berlin, Germany.

Importer for Great Britain:

Berlin Brands Group UK Ltd
 PO Box 1145
 Oxford, OX1 9UW
 United Kingdom

Estimado cliente,

Le felicitamos por la adquisición de este producto. Lea atentamente las siguientes instrucciones y sígalas para evitar posibles daños. No asumimos ninguna responsabilidad por los daños causados por el incumplimiento de las instrucciones y el uso inadecuado. Escanee el siguiente código QR para obtener acceso a la última guía del usuario y más información sobre el producto.



ÍNDICE

Vista general del aparato 16
 Montaje 17
 Montaje del techo 18
 Desmantelamiento 19
 Fabricante 19

DATOS TÉCNICOS

Número de artículo	10030605, 10030606, 10030607
Dimensiones (abierto)	76 x 51 x 20 cm
Dimensiones (plegado)	51 x 163 x 50 cm
Peso	9,5 kg
Carga máxima	68 kg
Alcance de suministro	Carrito plegable, techo, bolsa, bolsa refrigerante, bolsa de transporte, instrucciones de uso

VISTA GENERAL DEL APARATO



MONTAJE



Abre las asas de la bolsa de transporte y saca el carrito plegable.



Separa el marco hasta que el carrito llegue a su máxima extensión.



Separa las ruedas traseras hasta que se encajen de forma audible.

MONTAJE DEL TECHO



Saque las barras de las esquinas del marco hasta que encajen en su lugar.





Tire de la lámina del techo sobre las tapas de los extremos de los postes.



Vista del interior: Los refuerzos de la esquina están dentro.

DESMANTELAMIENTO

	
<p>Primero empuja las ruedas traseras a su posición original.</p>	<p>Tire del cinturón en el medio del carrito mientras permite que las ruedas delanteras giren (no ponga peso sobre ellas).</p>
	
<p>Cuando las ruedas vuelvan a estar en línea, presione el marco y asegure las asas de nuevo con los cierres de velcro. Utilice la bolsa de transporte para el transporte protegido del carrito.</p>	

FABRICANTE E IMPORTADOR (REINO UNIDO)

Fabricante:

Chal-Tec GmbH, Wallstraße 16, 10179 Berlín, Alemania.

Importador para Gran Bretaña:

Berlin Brands Group UK Ltd
 PO Box 1145
 Oxford, OX1 9UW
 United Kingdom

Chère cliente, cher client,

Toutes nos félicitations pour l'acquisition de ce nouvel appareil. Veuillez lire attentivement et respecter les instructions de ce mode d'emploi afin d'éviter d'éventuels dommages. Nous ne saurions être tenus pour responsables des dommages dus au non-respect des consignes et à la mauvaise utilisation de l'appareil. Scannez le QR-Code pour obtenir la dernière version du mode d'emploi et des informations supplémentaires concernant le produit.



SOMMAIRE

Aperçu de l'appareil 22
 Montage 23
 Montage du toit 24
 Démontage 25
 Fabricant 25

FICHE TECHNIQUE

Numéro d'article	10030605, 10030606, 10030607
Dimensions ouvert	76 x 51 x 20 cm
Dimensions replié	51 x 163 x 50 cm
Poids	9,5 kg
Charge max	68 kg
Contenu de l'emballage	Chariot pliant, toit, sac, sac isotherme, sac de transport, mode d'emploi

APERÇU DE L'APPAREIL



MONTAGE



Ouvrez les poignées du sac de transport et retirez le chariot pliant.



Tirez sur le cadre jusqu'à ce que le chariot soit complètement déployé.



Écartez les roues arrière jusqu'à ce que vous les entendiez s'enclencher.

MONTAGE DU TOIT



Tirez les tiges hors des coins du cadre jusqu'à ce qu'elles s'enclenchent.





Tirez la bâche de toit sur les embouts des tiges.



Vue de l'intérieur : les renforts d'angle se trouvent à l'intérieur.

DÉMONTAGE

	
<p>Repoussez d'abord les roues arrière vers leur position d'origine.</p>	<p>Tirez la sangle au milieu du chariot tout en permettant aux roues avant de tourner (ne pas forcer).</p>
	
<p>Lorsque les roues sont de nouveau alignées, appuyez sur le cadre pour le rassembler et fixez les poignées avec les attaches auto agrippantes. Utilisez le sac de transport pour transporter le chariot à l'abri.</p>	

FABRICANT ET IMPORTATEUR (UK)

Fabricant :

Chal-Tec GmbH, Wallstraße 16, 10179 Berlin, Allemagne.

Importateur pour la Grande Bretagne :

Berlin Brands Group UK Ltd
 PO Box 1145
 Oxford, OX1 9UW
 United Kingdom

Gentile cliente,

La ringraziamo per aver acquistato il dispositivo. La preghiamo di leggere attentamente le seguenti istruzioni per l'uso e di seguirle per evitare possibili danni. Non ci assumiamo alcuna responsabilità per danni scaturiti da una mancata osservazione delle avvertenze di sicurezza e da un uso improprio del dispositivo. Scansionare il codice QR seguente, per accedere al manuale d'uso più attuale e per ricevere informazioni sul prodotto.



INDICE

Descrizione del prodotto 28
 Montaggio 29
 Montaggio del tettuccio 30
 Smontaggio 31
 Produttore 31

DATI TECNICI

Codice articolo	10030605, 10030606, 10030607
Dimensioni aperto	76 x 51 x 20 cm
Dimensioni piegato	51 x 163 x 50 cm
Peso	9,5 kg
Carico max.	68 kg
Fornitura	Carretto pieghevole, tettuccio, sacca, borsa termica, borsa per il trasporto, manuale di istruzioni

DESCRIZIONE DEL PRODOTTO



MONTAGGIO



Aprire i manici della borsa ed estrarre il carrello pieghevole.



Distendere il telaio finché il carrello non è completamente aperto.



Far scorrere le ruote posteriori distanziandole finché non scattano in posizione.

MONTAGGIO DEL TETTUCCIO



Sfilare le barre dagli angoli del telaio finché non scattano in posizione.





Tirare il telo di copertura sopra il cappuccio delle barre.



Veduta del lato interno: i sostegni angolari si trovano all'interno.

SMONTAGGIO

	
<p>Innanzitutto occorre spingere le ruote posteriori nella posizione iniziale.</p>	<p>Tirare la cinghia al centro del carretto mentre si consente alle ruote anteriori di girarsi (non sollecitare).</p>
	
<p>Quando le ruote sono nuovamente allineate comprimere il telaio e fissare i manici con il velcro. Utilizzare la borsa di trasporto per proteggere il carretto durante gli spostamenti.</p>	

PRODUTTORE E IMPORTATORE (UK)

Produttore:

Chal-Tec GmbH, Wallstraße 16, 10179 Berlino, Germania.

Importatore per la Gran Bretagna:

Berlin Brands Group UK Ltd

PO Box 1145

Oxford, OX1 9UW

United Kingdom

