



blumfeldt

Bermuda

Hollywoodschaukel
Swing Chair
Balancelle
Dondolo Hollywood
Columpio para jardín

10031459



Sehr geehrter Kunde,

wir gratulieren Ihnen zum Erwerb Ihrer Bäderliege. Lesen Sie die folgenden Hinweise sorgfältig durch und befolgen Sie diese, um möglichen Schäden vorzubeugen. Für Schäden, die durch Missachtung der Hinweise und unsachgemäßen Gebrauch entstehen, übernehmen wir keine Haftung. Scannen Sie den QR-Code, um Zugriff auf die aktuellste Bedienungsanleitung und weitere Informationen rund um das Produkt zu erhalten.



SICHERHEIT UND PFLEGE

Sicherheit

- Stecken Sie beim Zusammenbau die Hände nicht in bewegliche Teile der Liege.
- Überprüfen Sie nach dem Aufstellen der Hollywoodschaukel, ob sie stabil steht.

Reinigung und Pflege

- Wischen Sie das Gestänge mit einem feuchten Lappen.
- Verwenden Sie keine Scheuermittel und scharfen Reiniger.



Dear Customer,

Congratulations on purchasing this lounge swing. Please read this manual carefully and take care of the following hints on installation and use to avoid technical damages. Any failure caused by ignoring the items and cautions mentioned in the operation and installation instructions are not covered by our warranty and any liability. Scan the QR code to get access to the latest user manual and more product information.

SAFETY AND CARE

Safety notes

- When assembling the swing chair, do not hold your hands into moving parts.
- Check if the swing chair is stable after unfolding.

Cleaning and care

- Wipe the swing chair with a damp cloth.
- Do not use abrasive or strong detergents.

Chère cliente, cher client,

Toutes nos félicitations pour l'acquisition de ce nouvel appareil. Veuillez lire attentivement et respecter les instructions de ce mode d'emploi afin d'éviter d'éventuels dommages. Nous ne saurions être tenus pour responsables des dommages dus au non-respect des consignes et à la mauvaise utilisation de l'appareil. Scannez le QR-Code pour obtenir la dernière version du mode d'emploi ainsi que d'autres informations concernant le produit.



SÉCURITÉ ET ENTRETIEN

Sécurité

- Essuyez la structure avec un chiffon humide.
- Ne pas utiliser d'abrasifs et de nettoyeurs agressifs.

Nettoyage et entretien

- Essuyez la structure avec un chiffon humide.
- Ne pas utiliser d'abrasifs et de nettoyeurs agressifs.



Gentile Cliente,

La ringraziamo per aver acquistato il dispositivo. La preghiamo di leggere attentamente le seguenti istruzioni per l'uso e di seguirle per evitare possibili danni tecnici. Non ci assumiamo alcuna responsabilità per danni scaturiti da una mancata osservazione delle avvertenze di sicurezza e da un uso improprio del dispositivo. Scansionare il codice QR seguente, per accedere al manuale d'uso più attuale e per ricevere informazioni sul prodott

SICUREZZA E MANUTENZIONE

Sicurezza

- Non infilare le mani nei componenti mobili del dondolo mentre lo si assembla.
- Dopo aver posizionato il dondolo Hollywood, controllare che sia stabile.

Pulizia e manutenzione

- Pulire il telaio con un panno umido.
- Non utilizzare prodotti abrasivi o detergenti aggressivi.

Estimado cliente:

Le felicitamos por la adquisición de este columpio para jardín. Lea atentamente el siguiente manual y siga cuidadosamente las instrucciones de uso con el fin de evitar posibles daños. La empresa no se responsabiliza de los daños ocasionados por un uso indebido del producto o por haber desatendido las indicaciones de seguridad. Escanee el siguiente código QR para tener acceso al manual de instrucciones más actualizado y a información adicional sobre el producto..



LIMPIEZA Y CUIDADO

Seguridad

- Al montar el columpio, no encaje las manos en las partes móviles del mismo.
- Tras instalar el columpio para jardín, compruebe que esté montado de un modo estable.

Limpieza y cuidado

- Limpie las barras con un paño húmedo.
- No utilice productos abrasivos ni limpiadores corrosivos.

DE

TEILELISTE PARTS LIST LISTE DES PIÈCES

EN

LISTA DEI COMPONENTI LISTA DE PIEZAS

FR

IT

ES

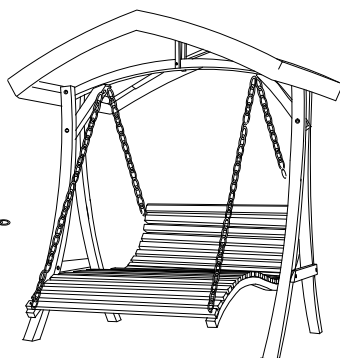
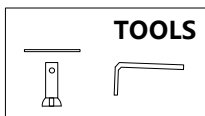
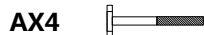
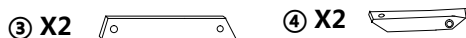
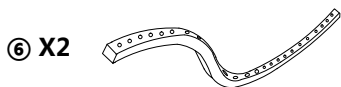

Werkzeug
outils
Attrezzi
Herramientas

MONTAGE ASSEMBLY ASSEMBLAGE

MONTAGGIO MONTAJE

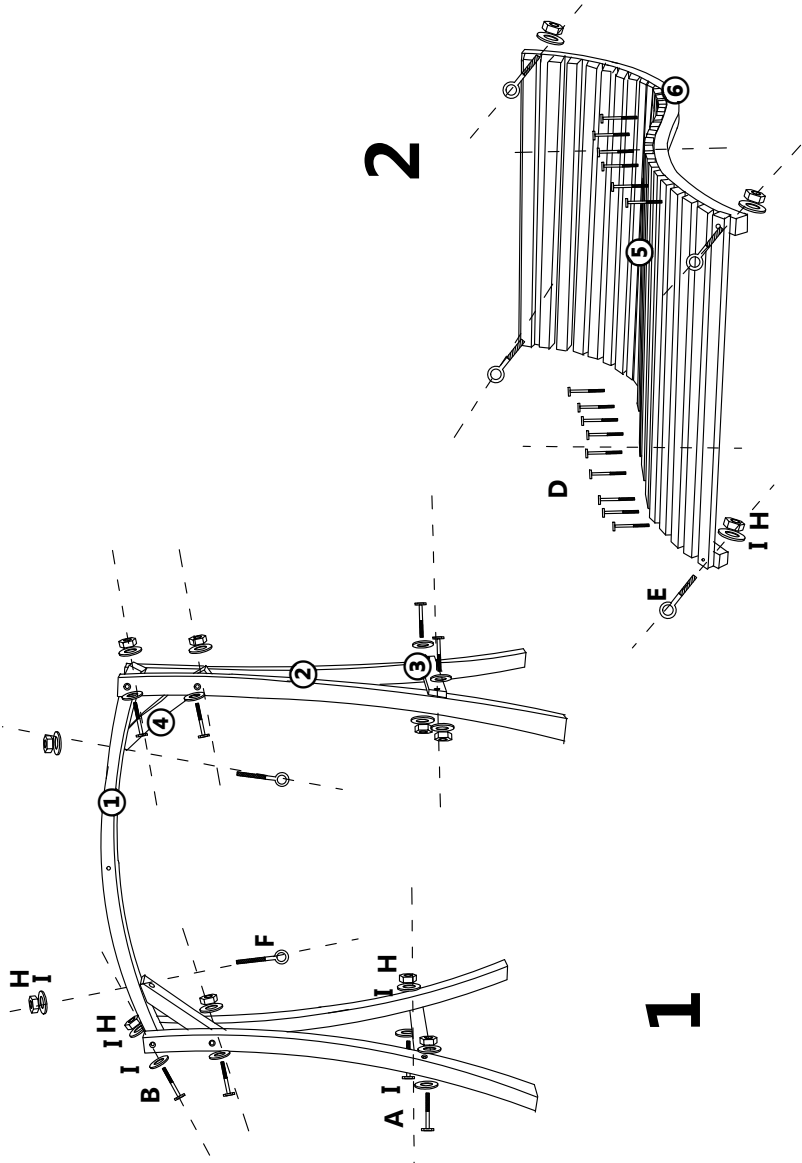

CANOPY Dach Tetto Toit Cubierta

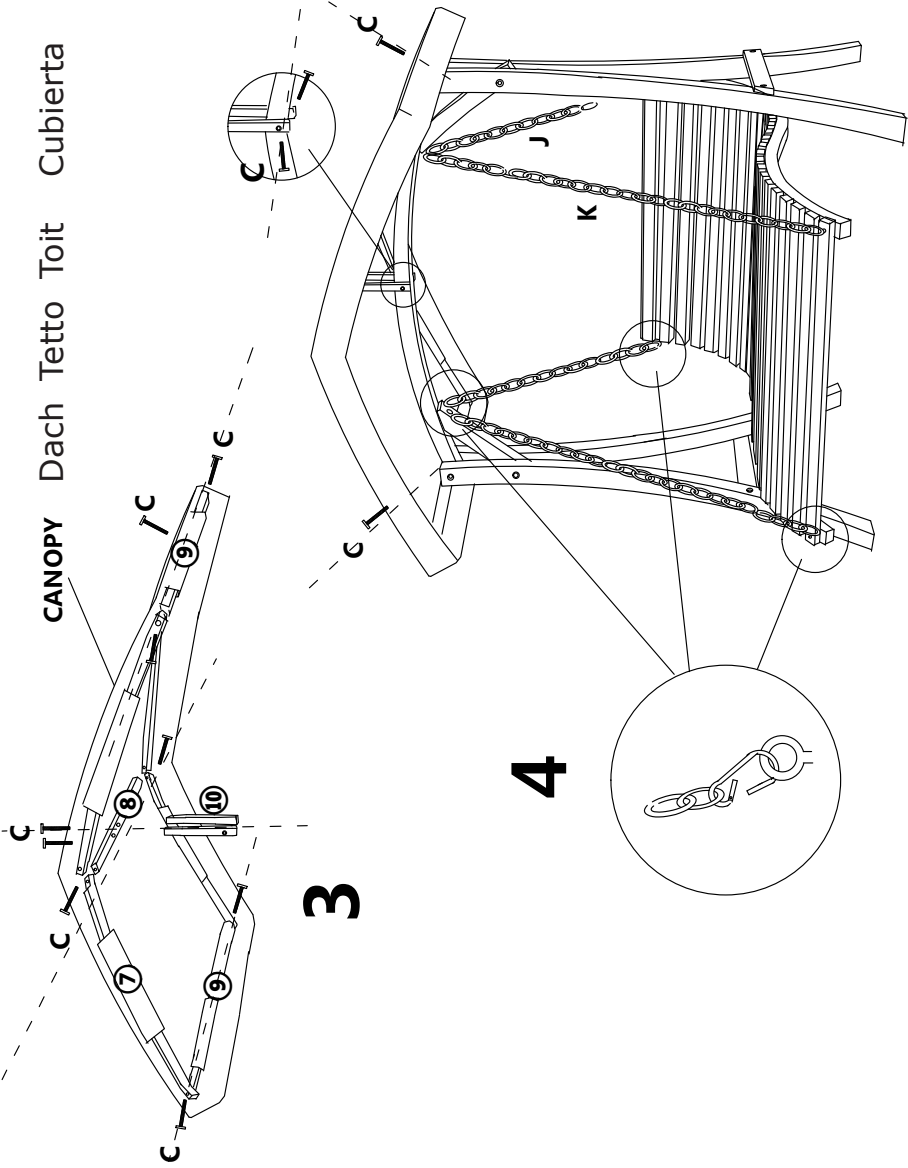

Hersteller: Chal-Tec GmbH, Wallstraße 16, 10179 Berlin, Deutschland

Producer: Chal-Tec GmbH, Wallstraße 16, 10179 Berlin, Germany

Fabricant : Chal-Tec GmbH, Wallstraße 16, 10179 Berlin, Allemagne

Produttore: Chal-Tec GmbH, Wallstraße 16, 10179 Berlino, Germania

Fabricante: Chal-Tec GmbH, Wallstraße 16, 10179 Berlín, Alemania

