

Hantelstation

10031714 10031715

KLAR  **FIT**

Sehr geehrter Kunde,

wir gratulieren Ihnen zum Erwerb Ihres Klarfit Gerätes. Lesen Sie alle Hinweise sorgfältig durch und befolgen Sie sie, um möglichen Schäden vorzubeugen. Für Schäden, die durch Missachtung der Sicherheitshinweise und unsachgemäßen Gebrauch entstehen, übernehmen wir keine Haftung.









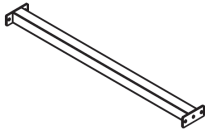
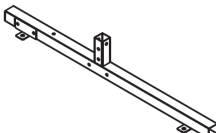
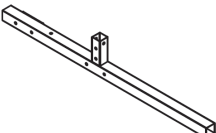
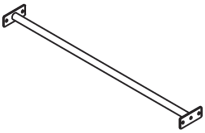
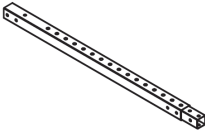
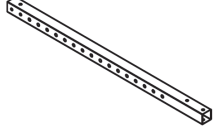

Sicherheitshinweise

- Behalten Sie die Verpackung und das Verpackungsmaterial nach dem Aufbau, falls Sie das Gerät irgendwann wieder abbauen oder transportieren müssen.
- Überprüfen Sie regelmäßig alle Schrauben und Verbindungen.
- Stellen Sie das Gerät an einen Ort, der genug Platz für das Gerät bietet.
- Stellen Sie das Gerät auf einen ebenen Untergrund und legen Sie eine Matte darunter, um Ihren Boden zu schonen.
- Lassen Sie sich vor dem Training von Ihrem Hausarzt untersuchen.
- Ziehen Sie die rutschsicheren Abdeckungen auf den Muttern mit einem Schraubenschlüssel fest.
- Das Gerät ist nicht für den kommerziellen Gebrauch, sondern nur für Gebrauch im Haushalt und in ähnlichen Umgebungen vorgesehen.
- Ziehen Sie alle Schrauben vor der Benutzung gut an, um Verletzungen zu vermeiden.
- Um die Verletzungsgefahr zu minimieren, nehmen Sie keine Veränderungen am Gerät vor, die so nicht in der Anleitung stehen.
- Verstauen Sie das Gerät an einem trockenen Ort. Verstauen Sie es nicht an heißen Orten oder Orten, an denen direktes Sonnenlicht auf das Gerät fällt.
- Reinigen Sie das Gerät mit einem trockenen Lappen. Entfernen Sie Flecken mit einem Schwamm und klarem Wasser. Benutzen Sie zur Reinigung kein Benzin, Lösemittel oder Chemikalien.
- Achten Sie während der Benutzung darauf, dass Sie Ihre Finger nirgendwo einklemmen.

Hersteller

Chal-Tec GmbH, Wallstraße 16, 10179 Berlin, Deutschland

Teile-Liste

			
1	1 PC	2	1 PC
			
5	2 PCS	6	2 PCS
		7	4 PCS
		M10*70 Bolzen	
		M10*65 Bolzen	
			
9	1 PC	10	2 PCS
M10*65 Bolzen		M10 Unterlegscheibe	
		M10*65 Mutter	
		Endkappe	
			
13	PCS	14	48 PCS
		24 PCS	
		4 PCS	

Hinweis: PC/PCS = Stückzahl

Zusammenbau

Schritt 1

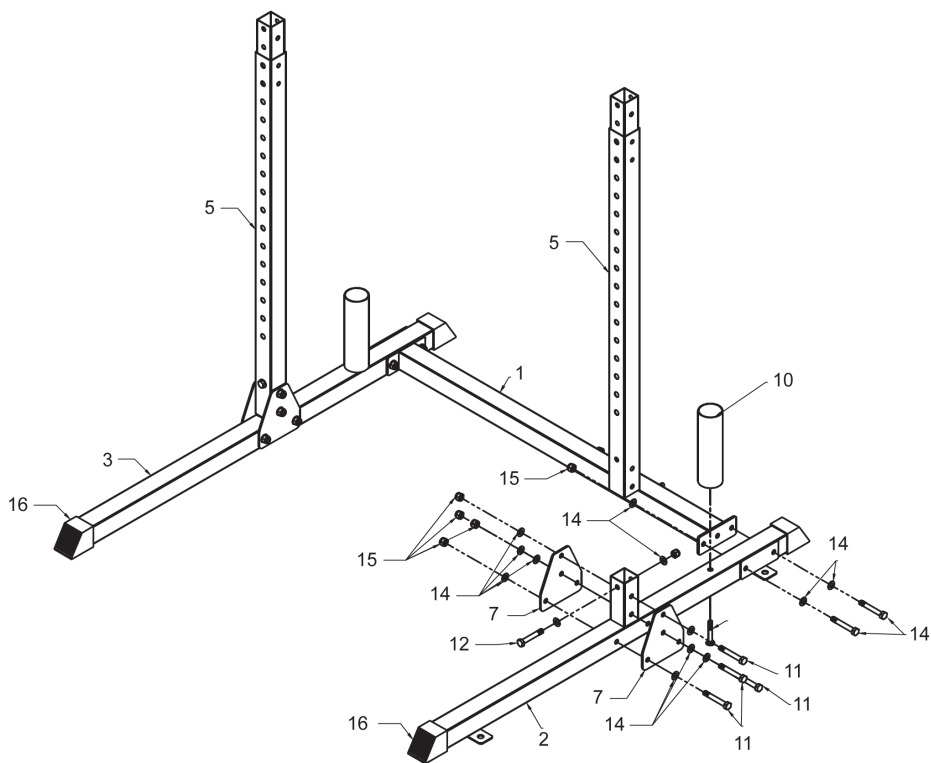

Ziehen Sie alle Muttern mit einem Schraubenschlüssel fest.

Schritt 2

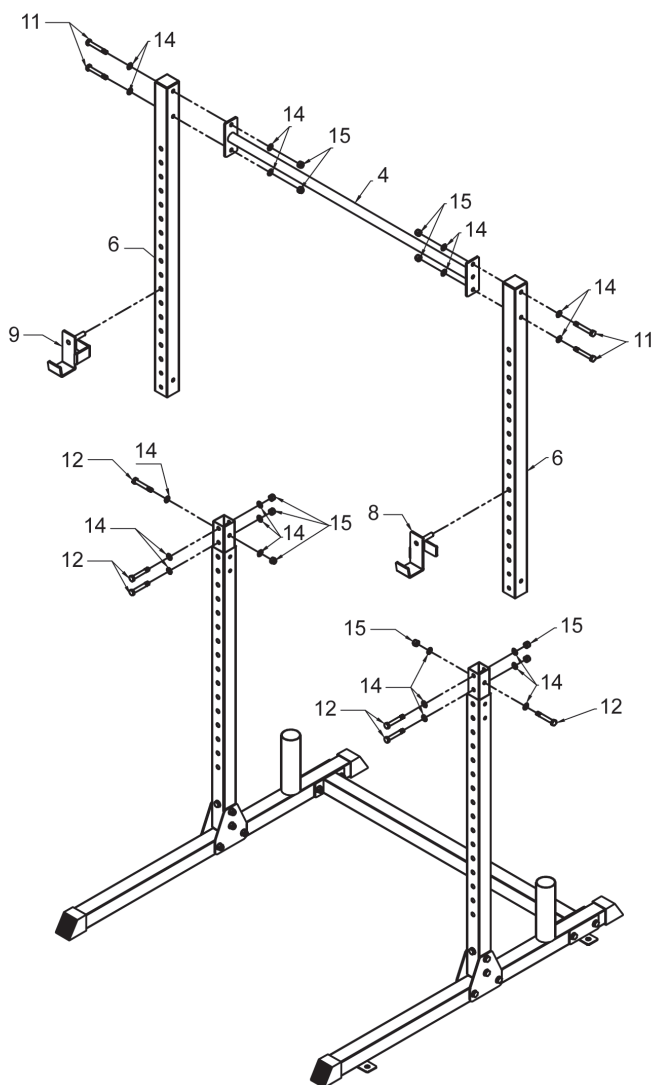

Ziehen Sie alle Muttern mit einem Schraubschlüssel fest.

Dear Customer,

Congratulations on purchasing this equipment. Please read this manual carefully and take care of the following hints to avoid damages. Any failure caused by ignoring the mentioned items and cautions mentioned in the instruction manual are not covered by our warranty and any liability.









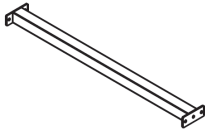
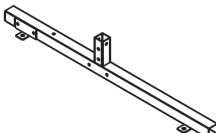
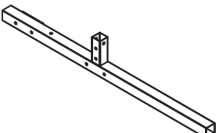
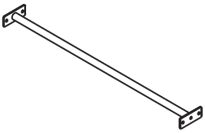
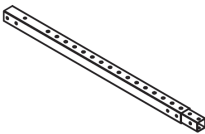
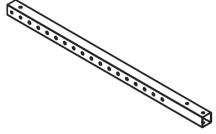

Safety Instructions

- Keep the box and the manual after installing the machine.
- Check the stability of the bolts regularly.
- Please install the machine in a commodious place.
- Put the machine on the level ground, and use a mat to protect the floor.
- Please consult to your doctor, physician before using any exercise equipments.
- There are slip proof cover on the nut (little nylon circle on the nut); please tighten them with wrench.
- The product is only for Domestic use not for Commercial purposes.
- Please tighten the screws; otherwise it might be dangerous to use.
- Please do not alter the machine in any way it might be dangerous to change and mend the machine.
- Store in the place where is away from moisture, salt (near Pool) high temperature and under sun.
- For maintenance and cleaning exercise machines Please clean the dirt with detergent scour, using dry rag and clean water (do not use gas, dilution and other chemicals).
- Do not put your hands in the moving part of the machine when you are doing exercise.

Producer

Chal-Tec GmbH, Wallstraße 16, 10179 Berlin, Germany

Parts List

 1 1 PC	 2 1 PC	 3 1 PC	 4 1 PC
 5 2 PCS	 6 2 PCS	 7 4 PCS M10*70 Bolt	 8 1 PC M10*65 Bolt
 9 1 PC M10*65 Bolt	 10 2 PCS M10 Washer	 11 16 PCS M10*65 Lock Nut	 12 8 PCS End_Cap
 13 PCS	 14 48 PCS	 15 24 PCS	 16 4 PCS

Assembly

Step 1

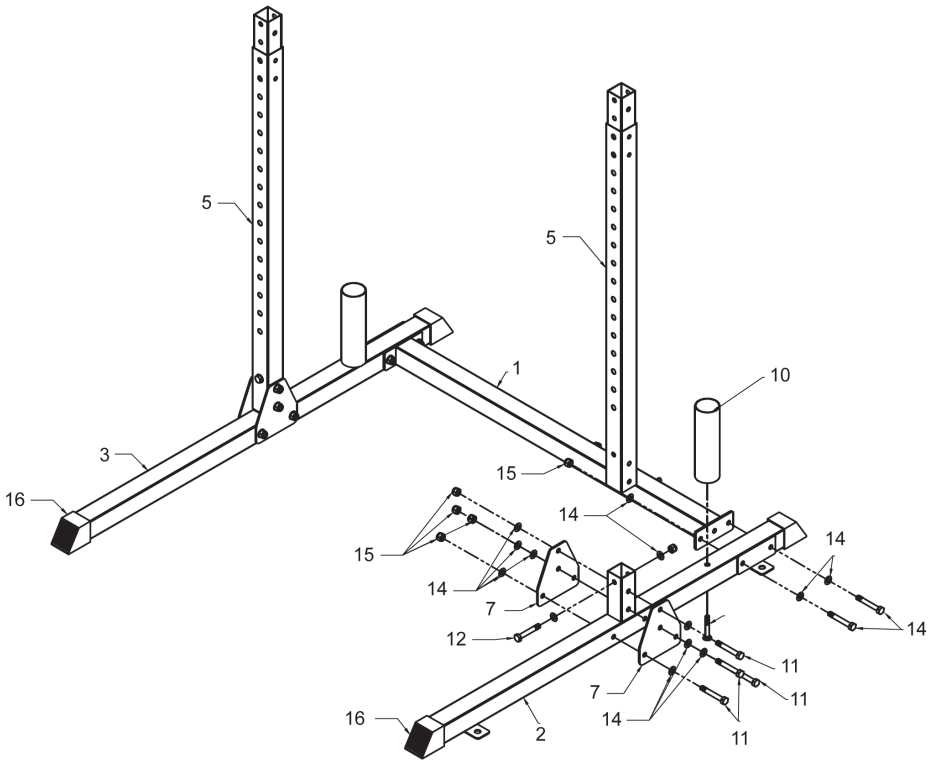

Tighten the slip proof cover on the nut with wrench.

Step 2

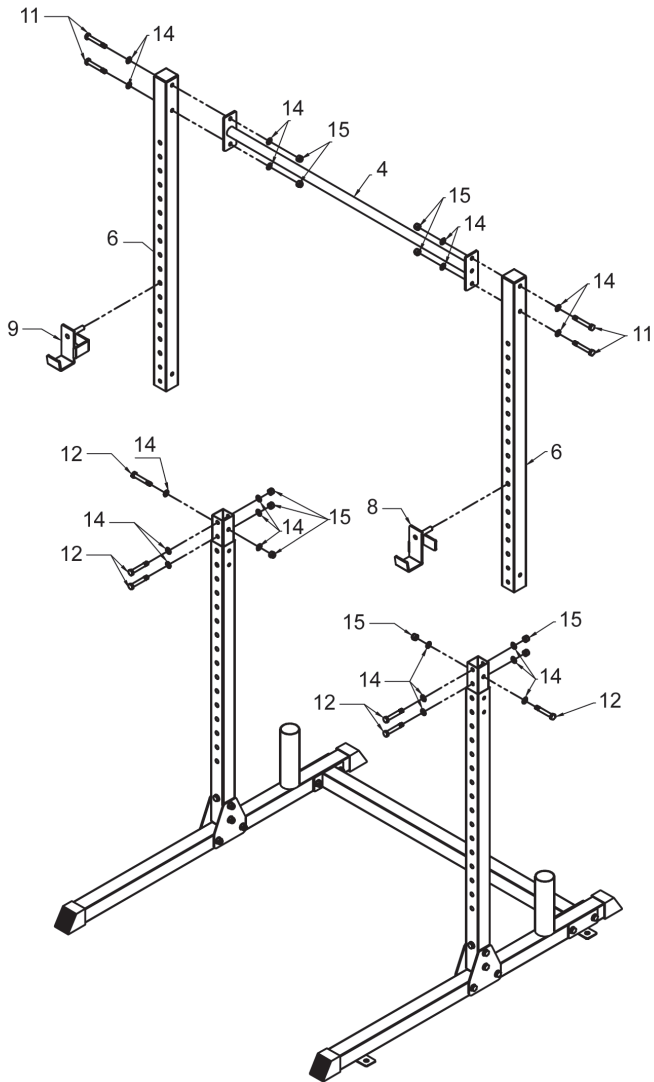

Tighten the slip proof cover on the nut with wrench.

Estimado cliente:

le felicitamos por la adquisición de este producto Klarfit. Lea atentamente el siguiente manual y siga cuidadosamente las instrucciones de uso con el fin de evitar posibles daños. La empresa no se responsabiliza de los daños ocasionados por un uso indebido del producto o por haber desatendido las indicaciones de seguridad.









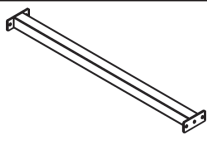
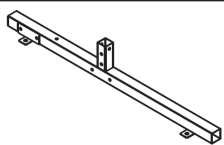
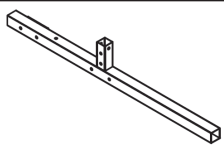
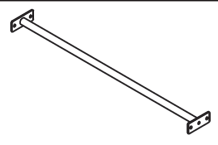
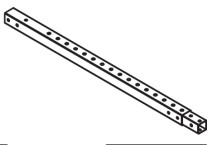
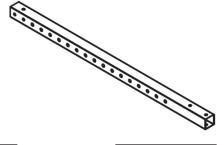

Indicaciones de seguridad

- Conserve la caja y el material de embalaje tras el montaje en caso de que necesite desmontar y transportar el aparato en un futuro.
- Compruebe regularmente todos los tornillos y juntas.
- Coloque el aparato en un lugar que ofrezca suficiente espacio.
- Coloque el aparato en una superficie plana y estable sobre una esterilla para proteger el suelo.
- Antes de iniciar el entrenamiento en el aparato, se recomienda realizar un reconocimiento médico.
- Apriete las cubiertas antideslizantes de las tuercas con una llave.
- Este aparato no ha sido concebido para un uso comercial, sino doméstico o para entornos similares.
- Apriete todos los tornillos antes de su uso para evitar lesiones.
- Para minimizar el riesgo de lesiones, no realice modificaciones en el aparato que no aparezcan en las instrucciones.
- Guarde el aparato en un lugar seco. No lo guarde en entornos calientes o donde la luz del sol incida directamente en el aparato.
- Limpie el aparato con un paño seco. Retire las manchas con una esponja y agua limpia.
- No utilice productos abrasivos, disolventes ni alcohol para la limpieza.
- Durante su uso, asegúrese de que los dedos no se quedan atrapados en ningún sitio.

Fabricante

Chal-Tec GmbH, Wallstraße 16, 10179 Berlín (Alemania)

Lista de piezas

			
1	1 PC	2	1 PC
			
5	2 PCS	6	2 PCS
		7	4 PCS
		Pernos M10*70	
		8	1 PC
		Pernos M10*65	
			
9	1 PC	10	2 PCS
Pernos M10*65		Arandela M10	
		11	16 PCS
		Tuerca con tapón M10*65	
		12	8 PCS
		Tapa posterior	
			
13	PCS	14	48 PCS
		15	24 PCS
		16	4 PCS

Advertencia: PC/PCS = Unidades

Montaje

Paso 1

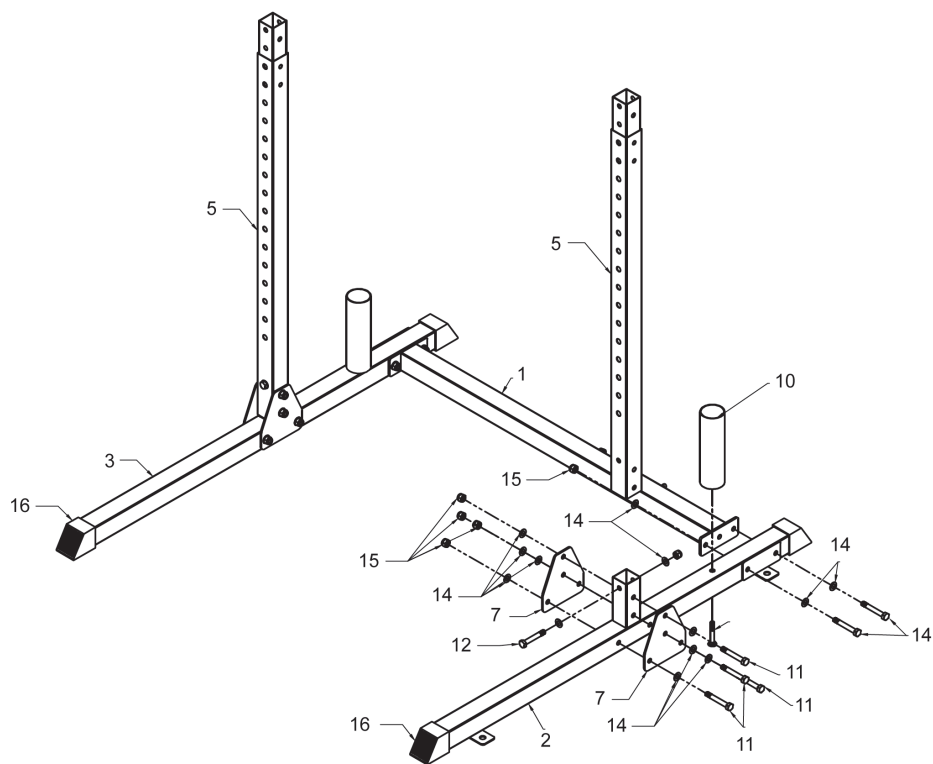

Apriete todas las tuercas con una llave.

Paso 2

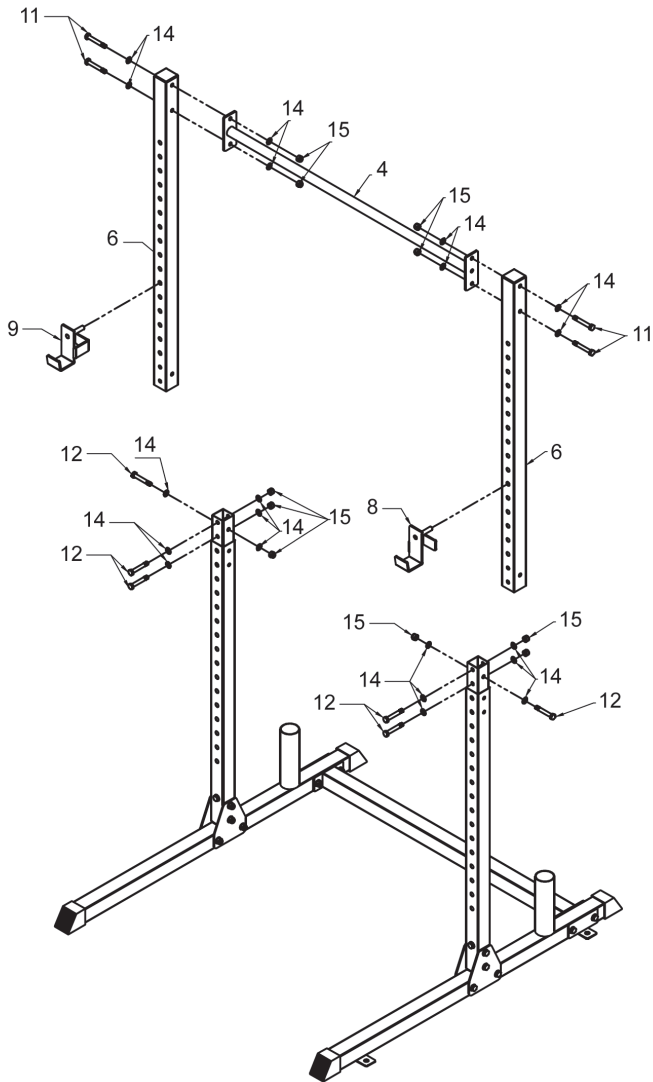

Apriete todas las tuercas con una llave.

Cher client,

Toutes nos félicitations pour l'acquisition de ce nouvel appareil. Veuillez lire attentivement les instructions suivantes de branchement et d'utilisation afin d'éviter d'éventuels dommages. Le fabricant ne saurait être tenu pour responsable des dommages dus au non-respect des consignes de sécurité et à la mauvaise utilisation de l'appareil.









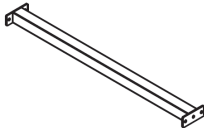
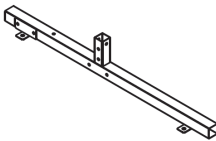
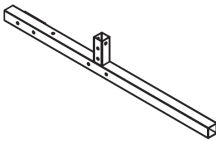
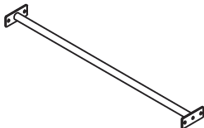
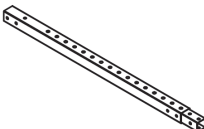
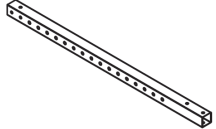

Consignes de sécurité

- Conservez l'emballage et les matériaux d'emballage même après l'assemblage, pour les utiliser si vous démontez un jour l'appareil ou si vous devez le transporter.
- Contrôlez régulièrement toutes les vis et les écrous.
- Installez l'appareil dans un endroit suffisamment spacieux.
- Installez l'appareil sur une surface plane et placez un tapis en-dessous pour préserver votre sol.
- Faites-vous examiner par votre médecin traitant avant de commencer l'entraînement.
- Vissez les embouts antidérapants sur les écrous à l'aide d'une clé plate.
- L'appareil n'est pas destiné à un usage commercial mais domestique ou similaire.
- Avant l'utilisation, serrez bien toutes les vis pour éviter de vous blesser.
- Pour réduire les risques de blessures, ne faites aucune modification sur l'appareil par rapport aux instructions de ce guide.
- Conservez l'appareil dans un endroit sec. Ne le rangez pas dans des lieux très chauds ou exposé à l'ensoleillement direct.
- Nettoyez l'appareil avec un chiffon sec. Enlevez les taches à l'éponge et à l'eau claire. Pour le nettoyage, n'utilisez pas d'essence, de diluant ou de produits chimiques.
- Pendant l'utilisation, faites attention à ne pas vous coincer les doigts.

Fabricant

Chal-Tec GmbH, Wallstraße 16, 10179 Berlin, Allemagne

Liste des pièces

 1 1 PC	 2 1 PC	 3 1 PC	 4 1 PC
 5 2 PCS	 6 2 PCS	 7 4 PCS Boulon M10*70	 8 1 PC Boulon M10*65
 9 1 PC Boulon M10*65	 10 2 PCS Rondelle M10	 11 16 PCS Ecrou M10*65	 12 8 PCS Embout
 13 PCS	 14 48 PCS	 15 24 PCS	 16 4 PCS

Remarque : PC/PCS = nombre d'éléments

Assemblage

Etape 1

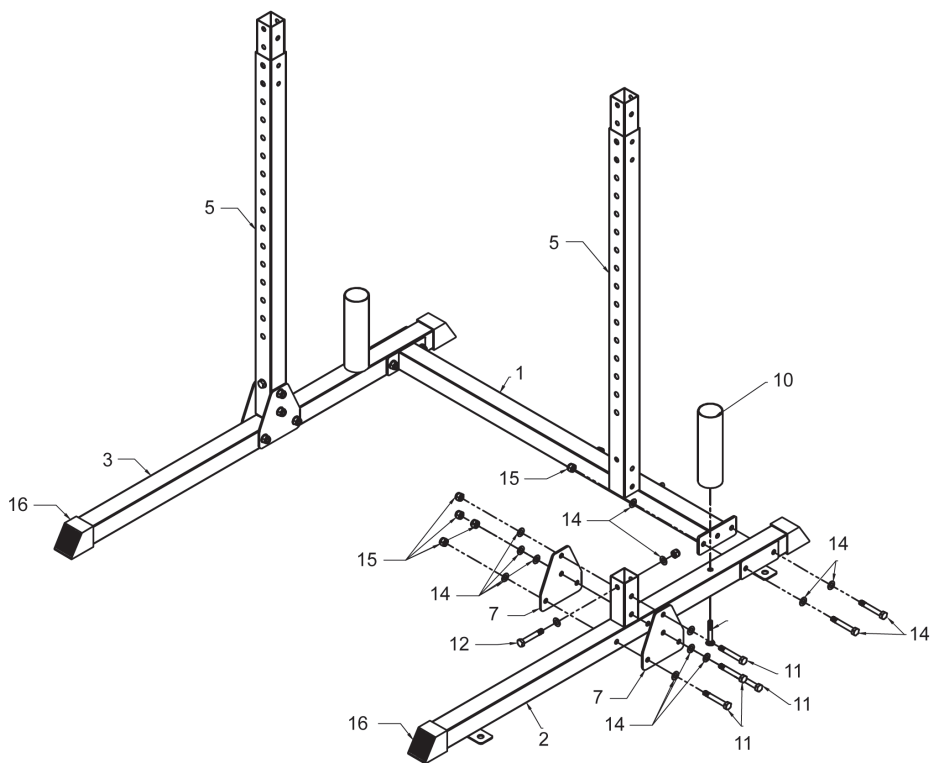

Serrez tous les écrous avec une clé plate.

Etape 2

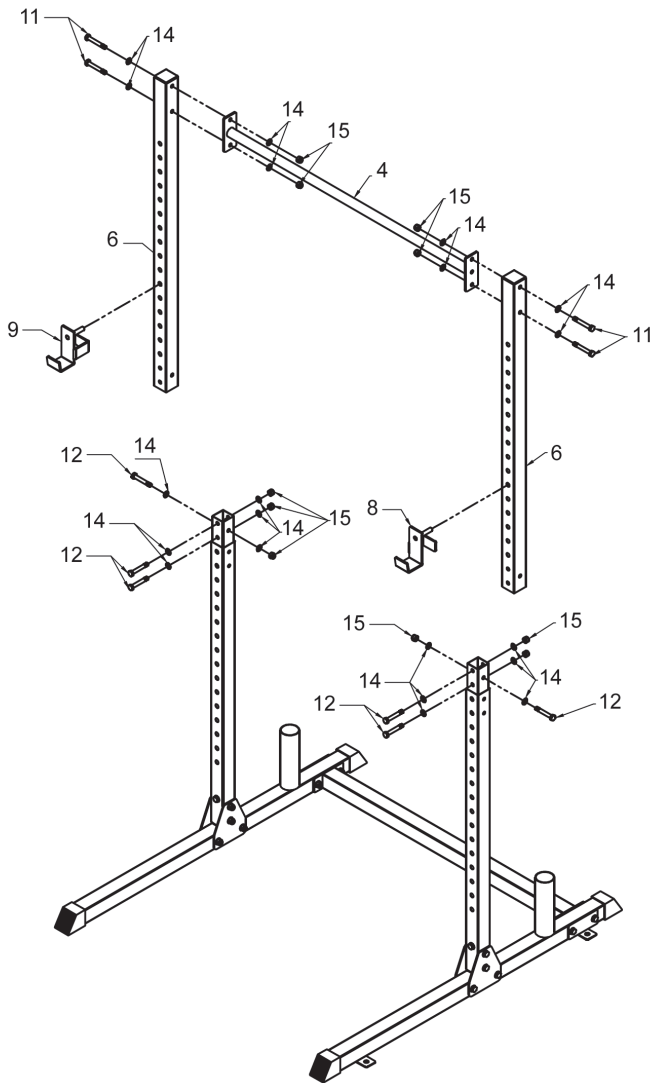

Serrez tous les écrous avec une clé plate.

Gentile cliente,

La ringraziamo per aver acquistato il nostro prodotto. La preghiamo di leggere attentamente le seguenti istruzioni e di seguirle per evitare eventuali danni. Non ci assumiamo alcuna responsabilità per danni derivati da una mancata osservazione delle avvertenze di sicurezza e da un uso improprio del dispositivo.









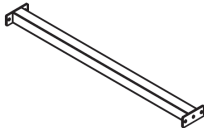
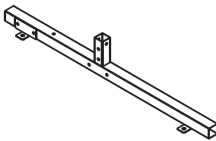
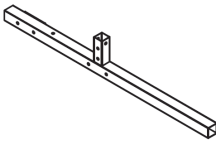
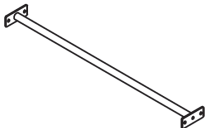
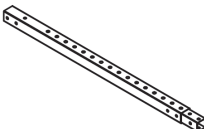
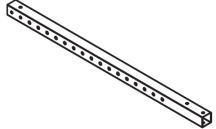

Avvertenze di sicurezza

- Conservare la confezione ed il materiale di imballaggio dopo il montaggio, nel caso in cui fosse necessario in futuro smontare il dispositivo o trasportarlo.
- Controllare regolarmente tutte le viti e i collegamenti.
- Collocare il dispositivo in un luogo con spazio sufficiente.
- Posizionare il dispositivo su una superficie piana. Utilizzare un tappetino per proteggere il pavimento.
- Prima di iniziare ad allenarsi, farsi visitare dal proprio medico.
- Serrare i coperchi antiscivolo sui dadi utilizzando una chiave inglese.
- Il dispositivo non è per un uso commerciale, bensì domestico e in ambienti simili.
- Serrare tutte le viti prima dell'uso per evitare infortuni.
- Per ridurre al minimo il rischio di infortuni, non apportare alcuna modifica al dispositivo.
- Conservare il dispositivo in un luogo asciutto. Non conservarlo in un luogo caldo e non esporlo alla luce diretta del sole.
- Pulire il dispositivo con un panno asciutto. Rimuovere le macchie con una spugna e con acqua pulita. Non utilizzare benzina, solventi o prodotti chimici.
- Prestare attenzione affinché le dita non restino incastrate nel dispositivo.

Produttore

Chal-Tec GmbH, Wallstraße 16, 10179 Berlino, Germania

Lista dei componenti

			
1	1 PC	2	1 PC
			
5	2 PCS	6	2 PCS
		7	4 PCS
		Bullone M10*70	
		8	1 PC
		Bullone M10*65	
			
9	1 PC	10	2 PCS
Bullone M10*65		Rondella M10	
		11	16 PCS
		Dado M10 *65	
		12	8 PCS
		Tappo chiusura	
			
13	PCS	14	48 PCS
		15	24 PCS
		16	4 PCS

Nota: PC/PCS = Pezzi

Assemblaggio

Fase 1

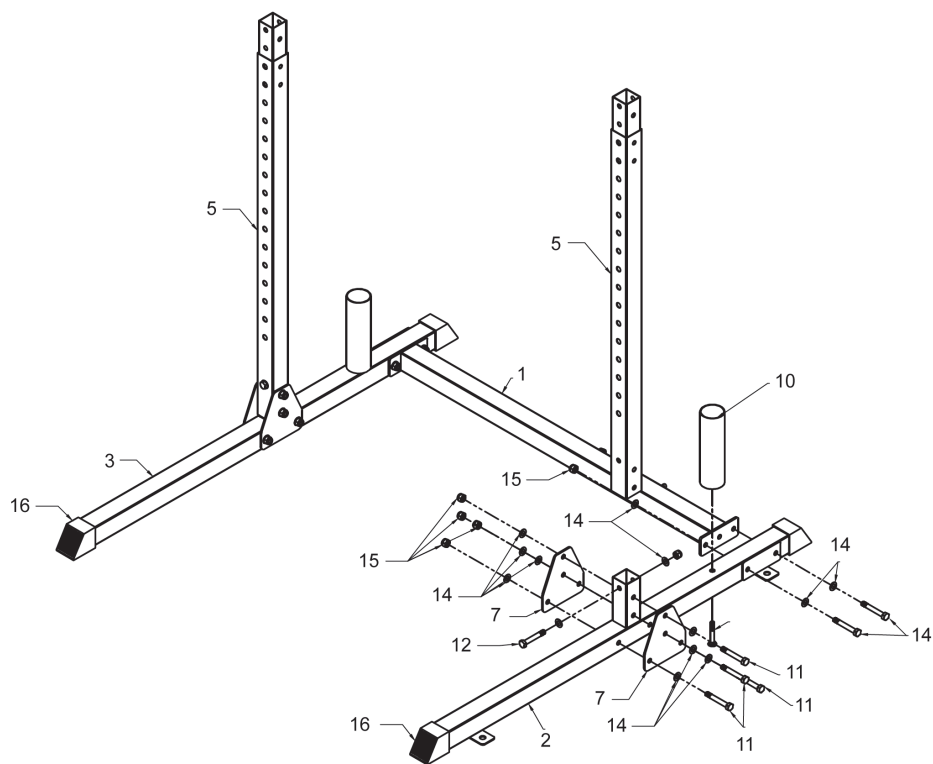

Serrare tutti i dadi con una chiave.

Fase 2

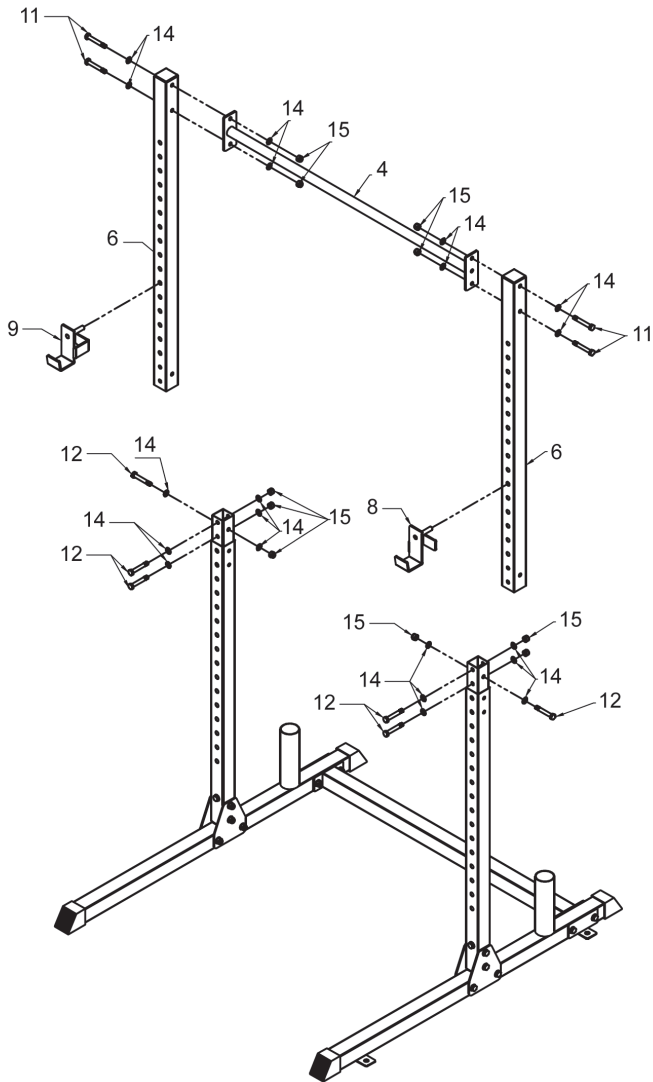

Serrare tutti i dadi con una chiave.