

KLARSTEIN NIELSTARK
TEIN NIELSTARK KLAR
KLARSTEIN NIELSTARK
TEIN NIELSTARK KLAR
KLARSTEIN NIELSTARK
TEIN NIELSTARK KLAR
KLARSTEIN NIELSTARK

Kamin-Gehäuse

Fireplace Housing

Carcasa de chimenea

Corps de cheminée

Alloggiamento camino

10033216

Sehr geehrter Kunde,

wir gratulieren Ihnen zum Erwerb Ihres Gerätes. Lesen Sie die folgenden Hinweise sorgfältig durch und befolgen Sie diese, um möglichen Schäden vorzubeugen. Für Schäden, die durch Missachtung der Hinweise und unsachgemäßen Gebrauch entstehen, übernehmen wir keine Haftung. Scannen Sie den folgenden QR-Code, um Zugriff auf die aktuellste Bedienungsanleitung und weitere Informationen rund um das Produkt zu erhalten:



INHALTSVERZEICHNIS

Lieferumfang 4
Benötigte Werkzeuge 5
Teileliste 6
Zusammenbau 7
Reinigung und Pflege 14

English 15
Español 27
Français 39
Italiano 51

HERSTELLER

Chal-Tec GmbH, Wallstraße 16, 10179 Berlin, Deutschland.

LIEFERUMFANG

① x 1

② x 1

③ x 1

④ x 1

⑤ x 1

⑥ x 2

⑦ x 1

⑧ x 1

⑨ x 1

⑩ x 1

⑪ x 2

⑫ x 1

⑬ x 1

⑭ x 1

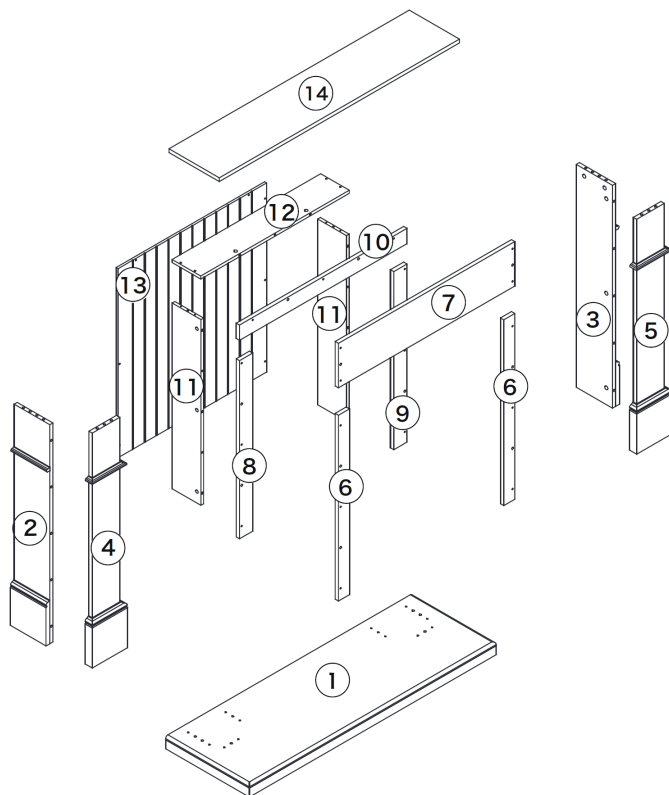

Hinweis: Suchen Sie einen Standort, an dem der Kamin vor direkter Sonneneinstrahlung geschützt ist.

BENÖTIGTE WERKZEUGE

Für die Installation benötigen Sie die folgenden Werkzeuge:

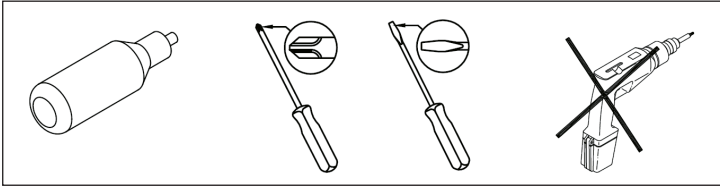

Hinweis: Der Holzleim ist nicht im Lieferumfang enthalten. Wir empfehlen Ihnen etwas Holzleim in die Löcher zu geben, bevor Sie die Holzdübel einsetzen.



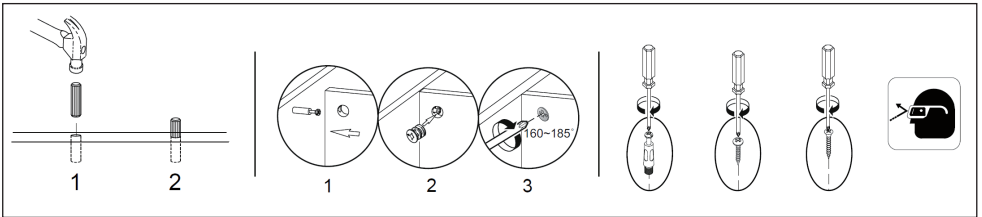









Benutzen Sie die Werkzeuge folgendermaßen:



Wichtige Hinweise zur Installation



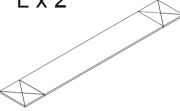

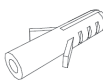
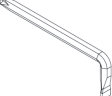
- Halten Sie sich genau an die Montageanleitung.
- Vergewissern Sie sich, dass im Karton alle Teile enthalten sind.
- Um Produktschäden zu vermeiden, montieren Sie das Gehäuse auf dem Karton.
- Reinigen Sie die Oberfläche des Gehäuses nur mit einem Staubwedel oder einem feuchten Tuch, verwenden Sie keine scheuernden Reinigungsmittel.

TEILELISTE

A x 14 	B x 14 	C x 16  Φ7.8 X 30 mm	D x 12  Φ7.8 X 20 mm
E x 19  Ø4x24mm	F x 8 	G x 9  Φ5.8 X 30 mm	H x 16  Ø4x50mm
I x 8 	J x 2  Ø4x14mm	K x 4 	L x 2 
M x 11  Ø4x35mm	N x 2 	O x 1 	

Hinweis: Die Verwendung der falschen Schraube kann zu Beschädigungen führen. Bevor Sie mit der Montage beginnen, sortieren Sie die einzelnen Schraubentypen.

Schraubenarten und Schraubenlängen

	E	Φ 4 X 24mm
	H	Φ 4 X 50mm
	J	Φ 4 X 14mm
	M	Φ 4 X 35mm
		

ZUSAMMENBAU

1



A x 3

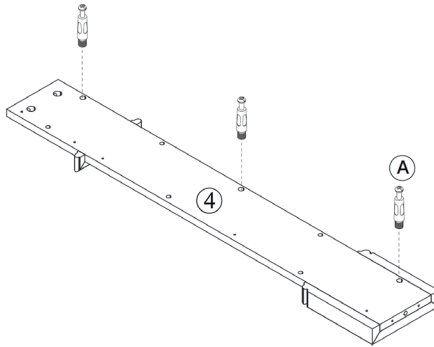

2



B x 5



C x 2

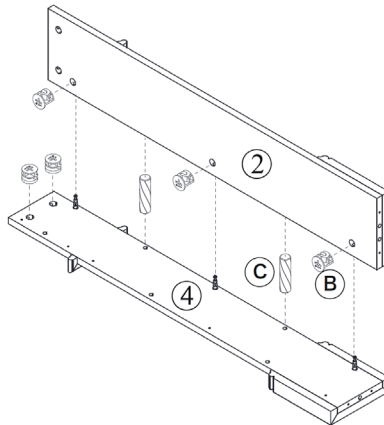

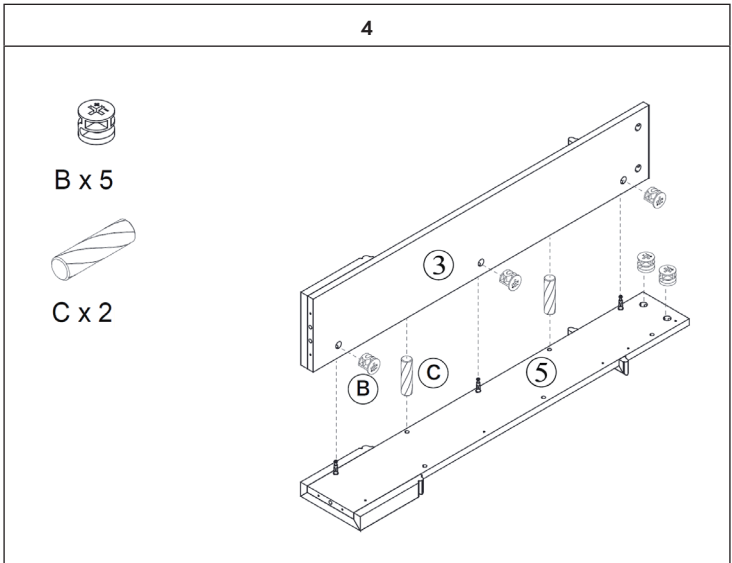
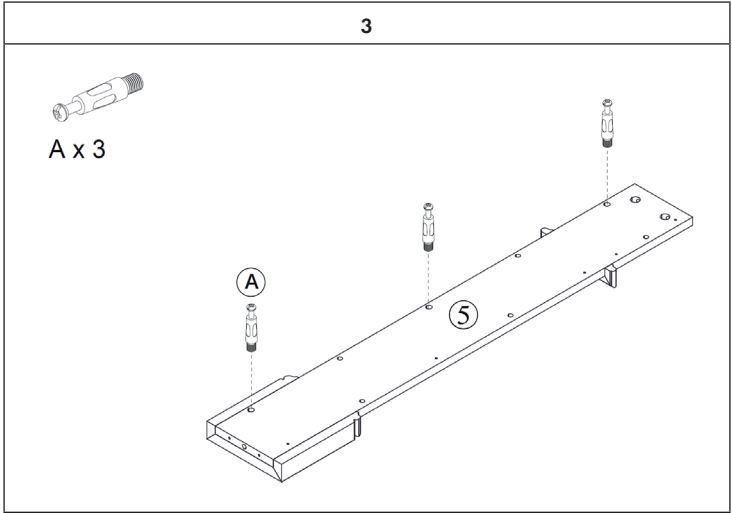

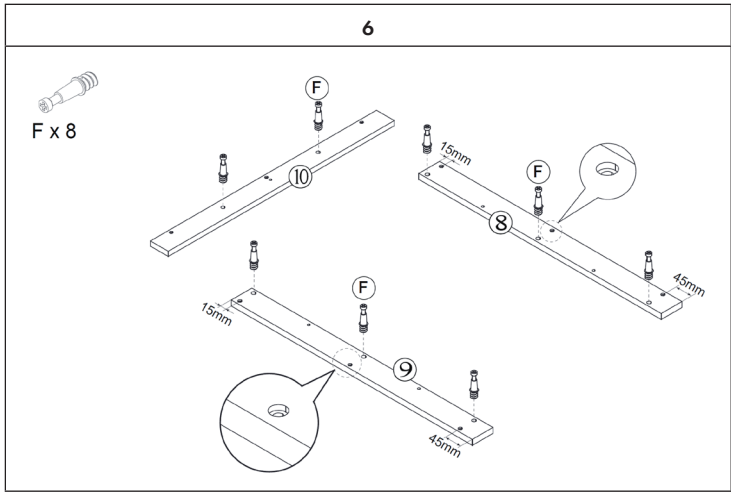
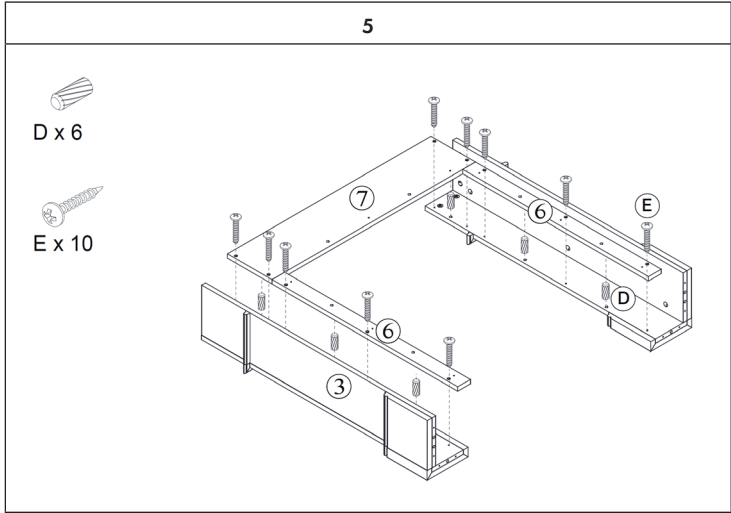

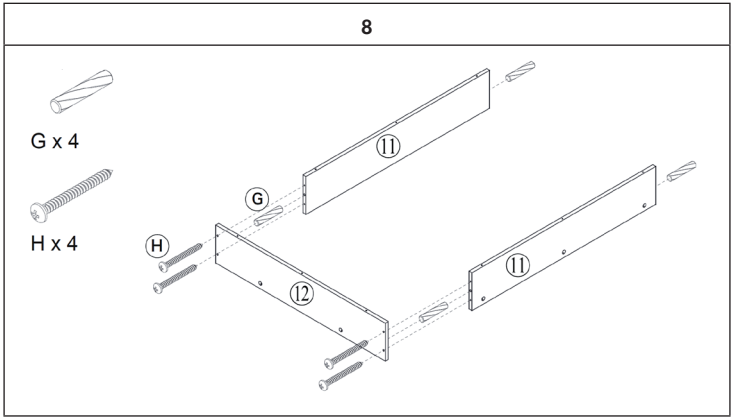
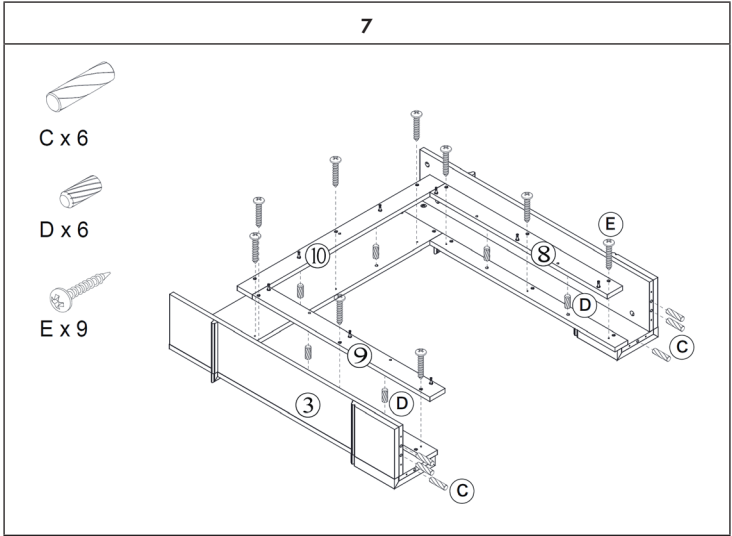

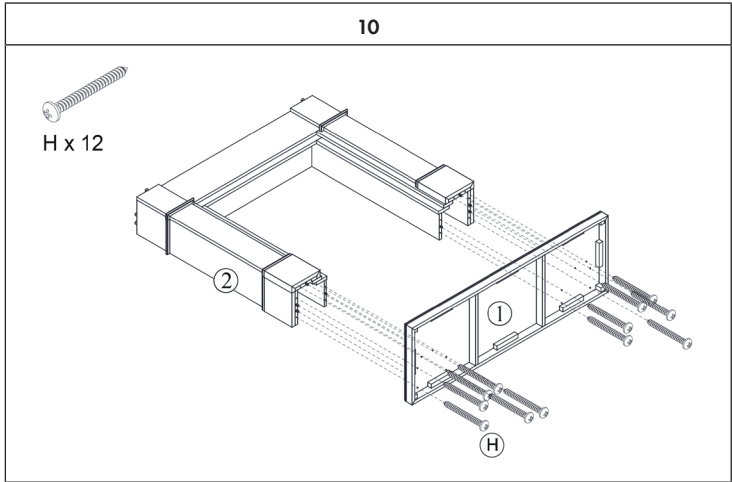
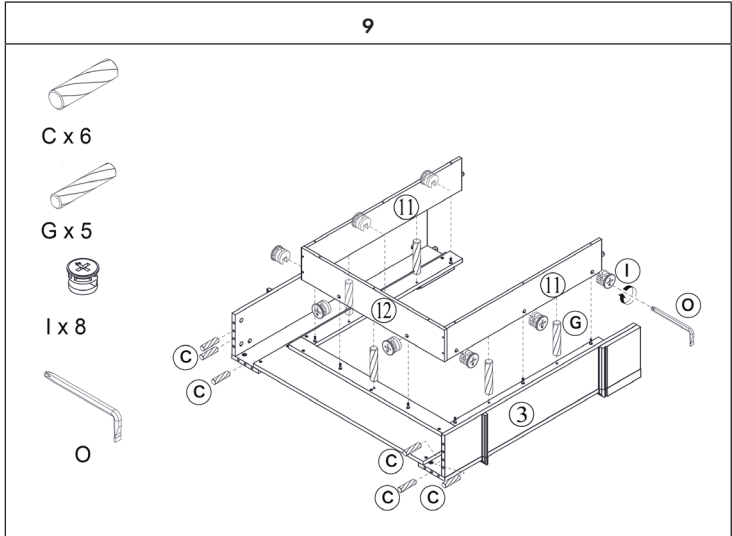

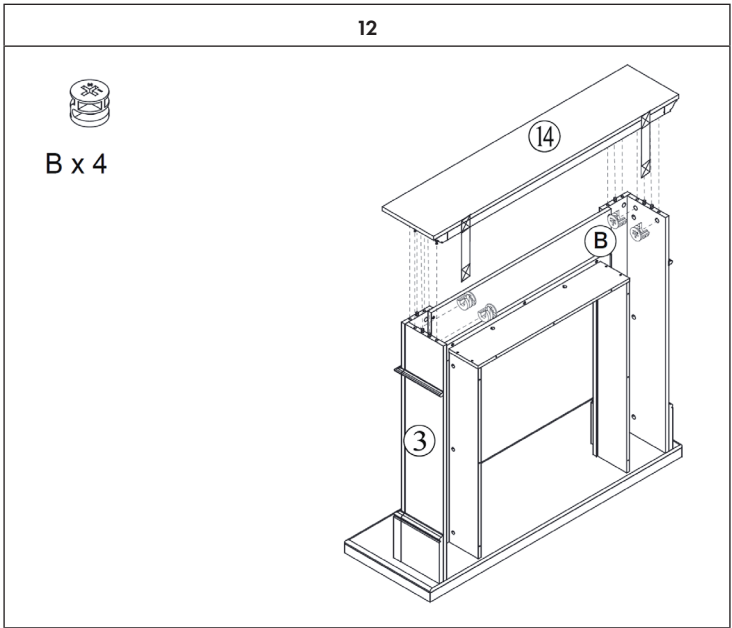
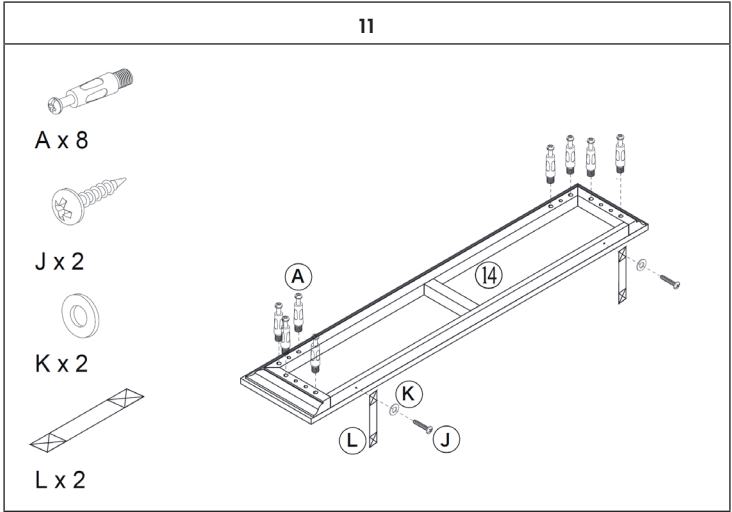

9



K x 2



M x 11



N x 2

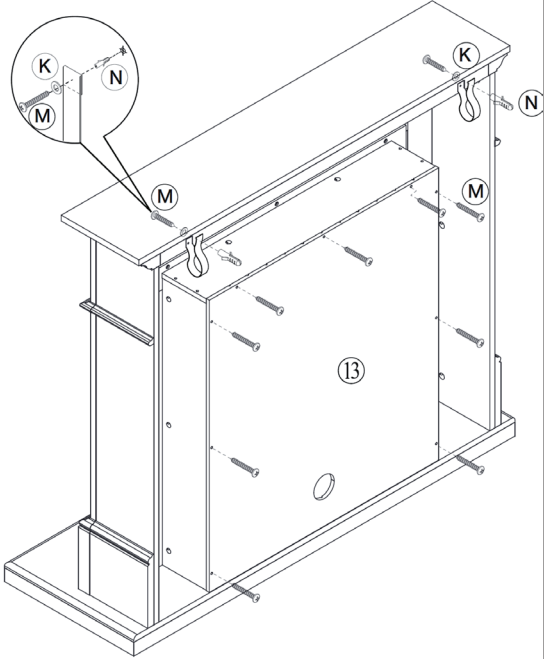

REINIGUNG UND PFLEGE

Hinweis: Schalten Sie das Gerät aus und ziehen Sie den Stecker aus der Steckdose. Warten Sie, bis das Gerät vollständig abgekühlt ist, bevor Sie sie reinigen.

- Benutzen Sie zur Reinigung der Lüftungsschlitze und Gitter einen Staubsauger.
- Entfernen Sie Staub auf den Außenflächen mit einem feuchten (nicht nassen) Tuch.
- Verwenden Sie keine scharfen Reinigungsmittel oder Scheuermittel.
- Besprühen Sie das Gerät nicht mit Flüssigkeiten und tauchen Sie es nicht in Wasser oder andere Flüssigkeiten.
- Öffnen Sie niemals das Gehäuse der Heizung.

Aufbewahrung

Bewahren Sie das Gerät während der Nebensaison an einem staubfreien Ort auf. Verpacken Sie es idealerweise im Originalkarton. Wickeln Sie das Kabel des Heizgerätes sauber auf, um eine Beschädigung des Kabels zu vermeiden.

Dear Customer,

Congratulations on purchasing this equipment. Please read this manual carefully and take care of the following hints to avoid damages. Any failure caused by ignoring the items and cautions mentioned in the instruction manual is not covered by our warranty and any liability. Scan the QR code to get access to the latest user manual and other information about the product



CONTENT

Packing Content 16
Necessary Tools 17
Parts List 18
Assembly 19
Cleaning and care 26

PRODUCER

Chal-Tec GmbH, Wallstraße 16, 10179 Berlin, Germany.

PACKING CONTENT

① x 1

② x 1

③ x 1

④ x 1

⑤ x 1

⑥ x 2

⑦ x 1

⑧ x 1

⑨ x 1

⑩ x 1

⑪ x 2

⑫ x 1

⑬ x 1

⑭ x 1

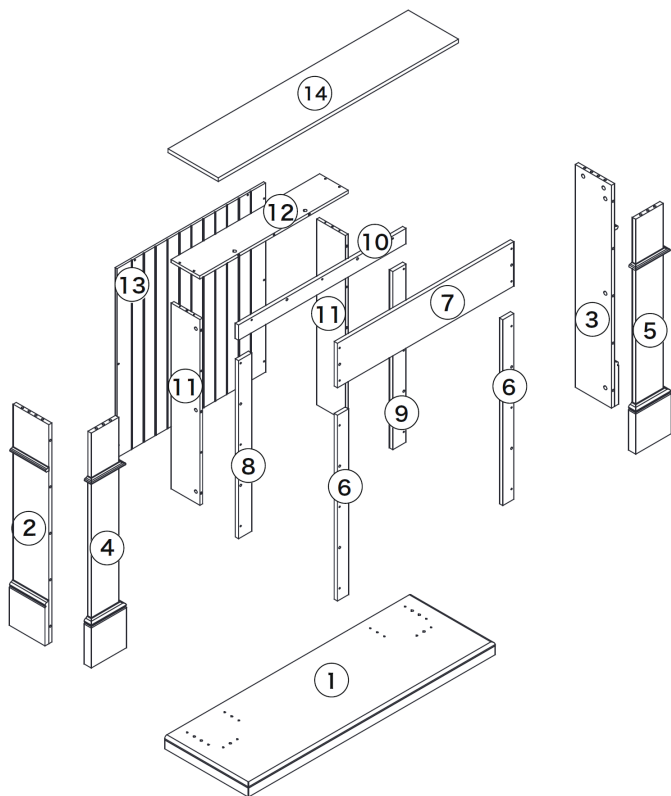

Note: Find a location where the fireplace is protected from direct sunlight.

NECESSARY TOOLS

For the installation you need the following tools:

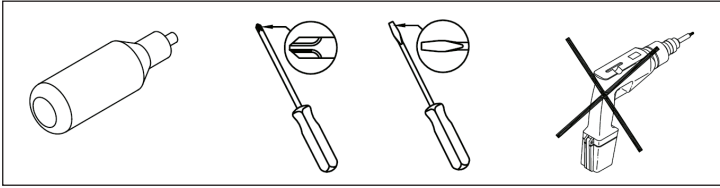

Note: The wood glue is not included in the delivery. We recommend that you add some wood glue to the holes before inserting the wood dowels.



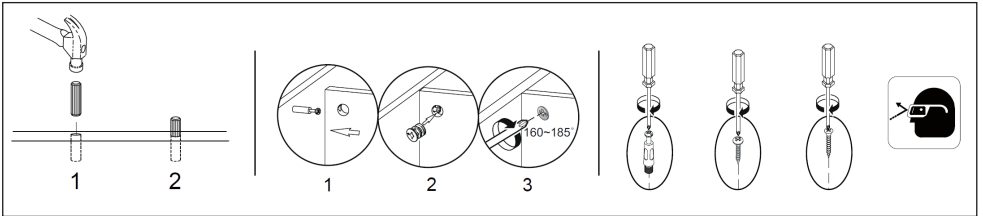









Use the tools as follows:



Important Notes on Installation

- Follow carefully the assembly instructions.
- Check to ensure this carton contains all parts.
- To prevent product damage, assemble the furniture on the carton.
- Clean surface of furniture with a duster or damp cloth only, do not use abrasive cleaners.

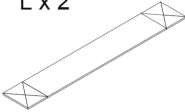
PARTS LIST

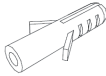
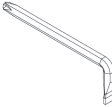
<p>A x 14</p> 	<p>B x 14</p> 	<p>C x 16</p>  <p>Φ7.8 X 30 mm</p>	<p>D x 12</p>  <p>Φ7.8 X 20 mm</p>
<p>E x 19</p>  <p>Ø4x24mm</p>	<p>F x 8</p> 	<p>G x 9</p>  <p>Φ5.8 X 30 mm</p>	<p>H x 16</p>  <p>Ø4x50mm</p>
<p>I x 8</p> 	<p>J x 2</p>  <p>Ø4x14mm</p>	<p>K x 4</p> 	<p>L x 2</p> 
<p>M x 11</p>  <p>Ø4x35mm</p>	<p>N x 2</p> 	<p>O x 1</p> 	

Note: Using the wrong screw may result in damage. Before you begin assembly, sort the individual screw types.

Screw types and lengths

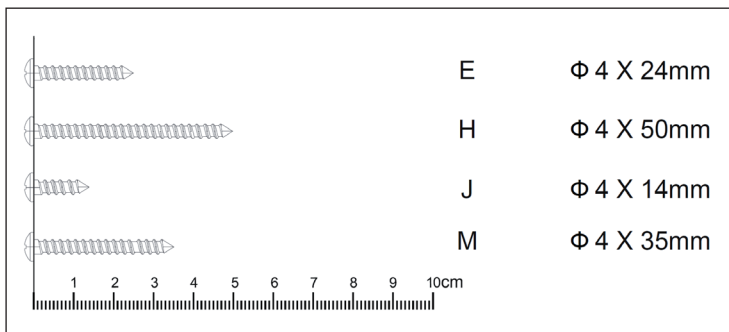

ASSEMBLY

1



A x 3

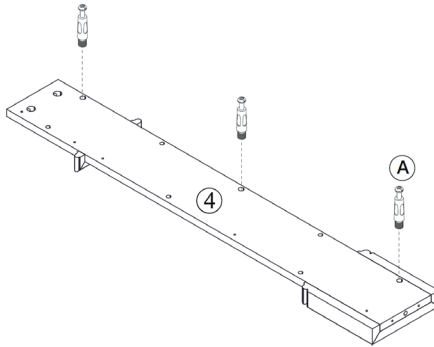

2



B x 5



C x 2

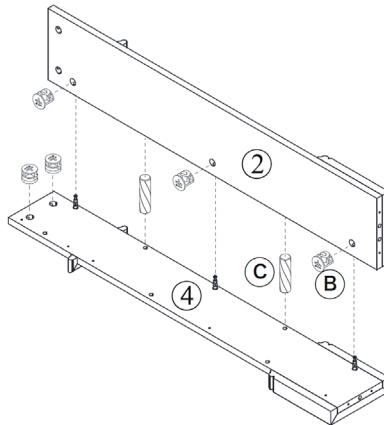

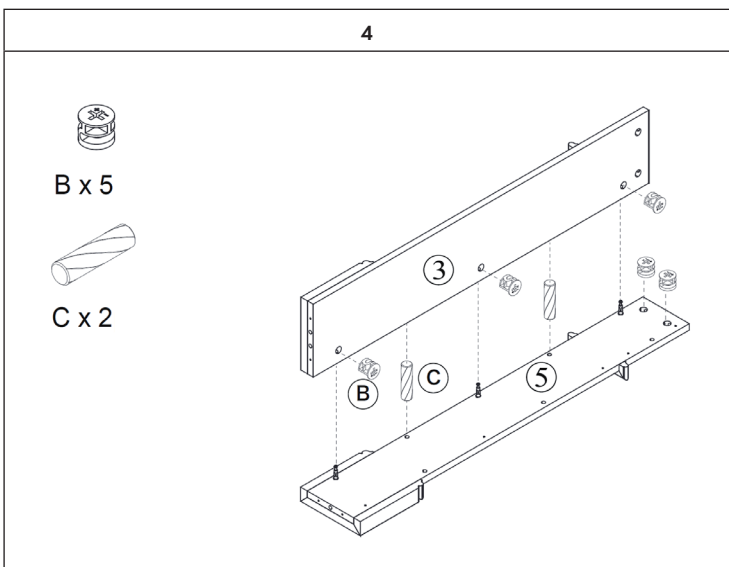
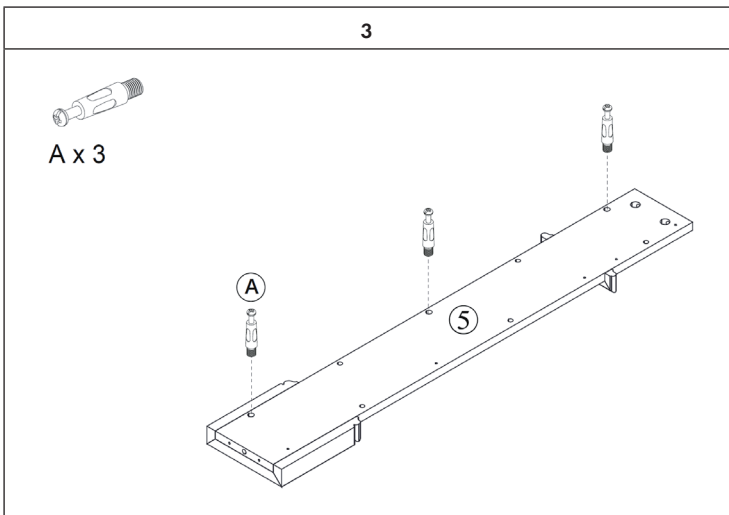

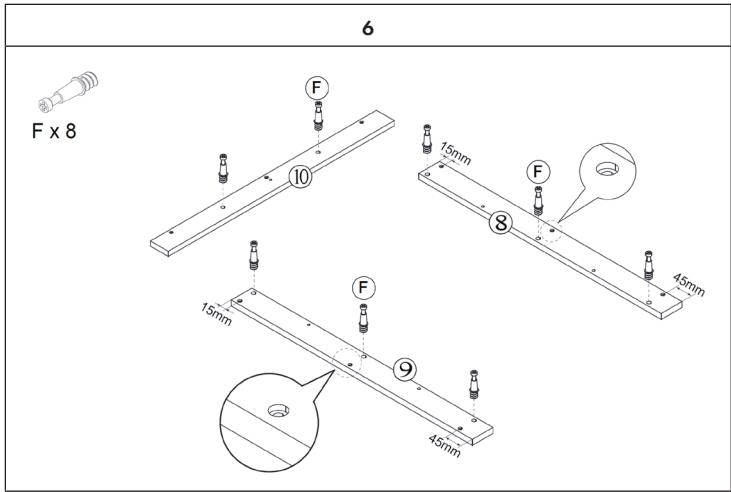
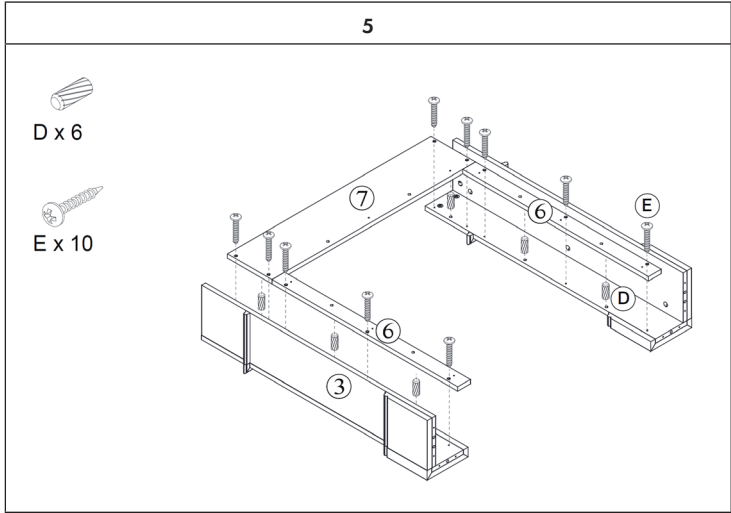

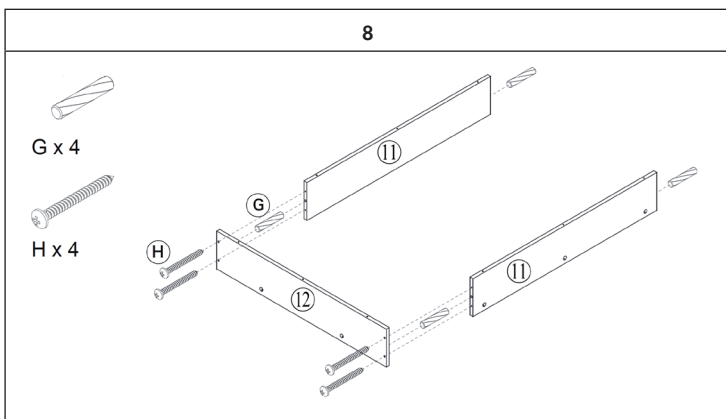
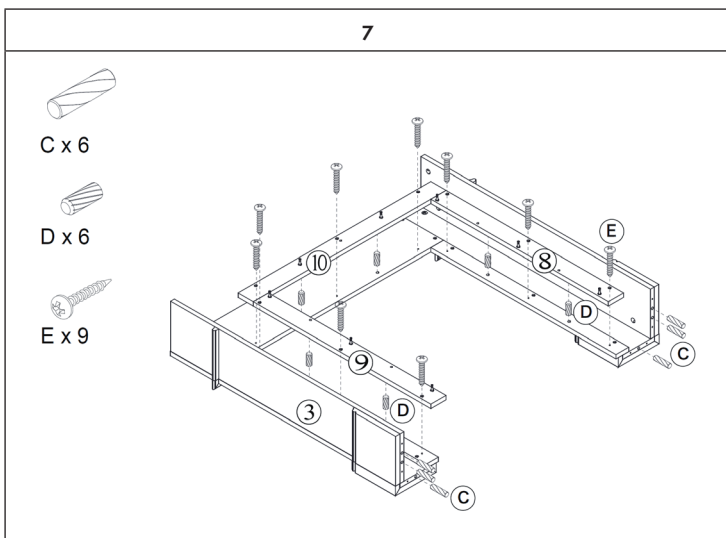

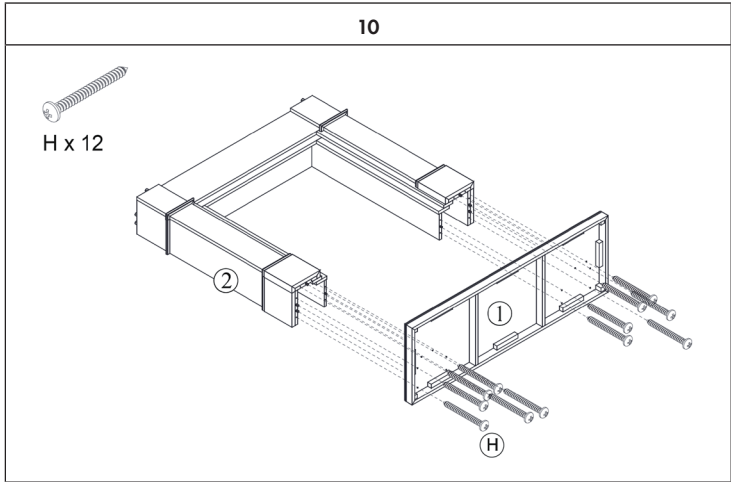
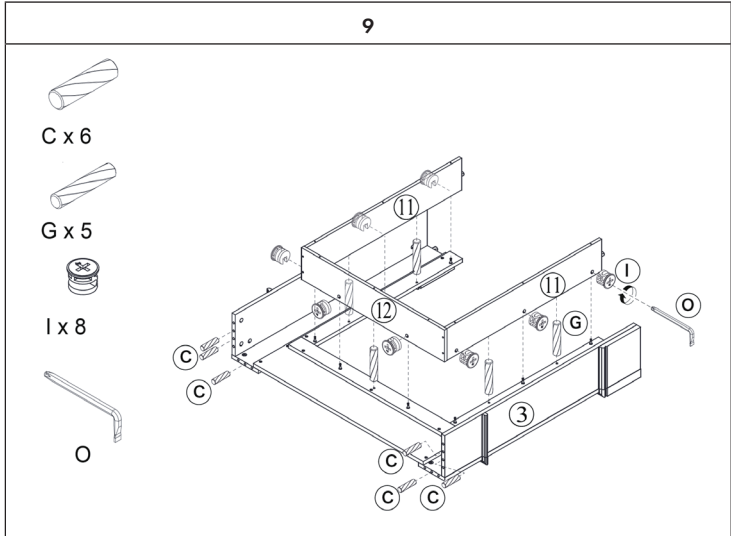

11



A x 8



J x 2



K x 2

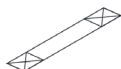

L x 2

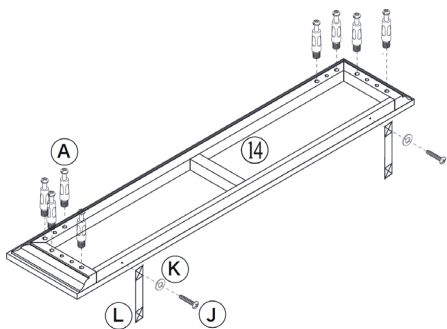

12



B x 4

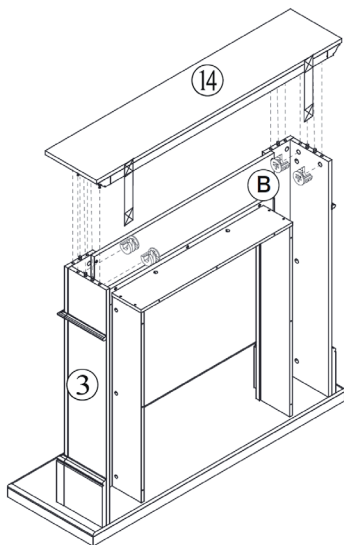

9



K x 2



M x 11



N x 2

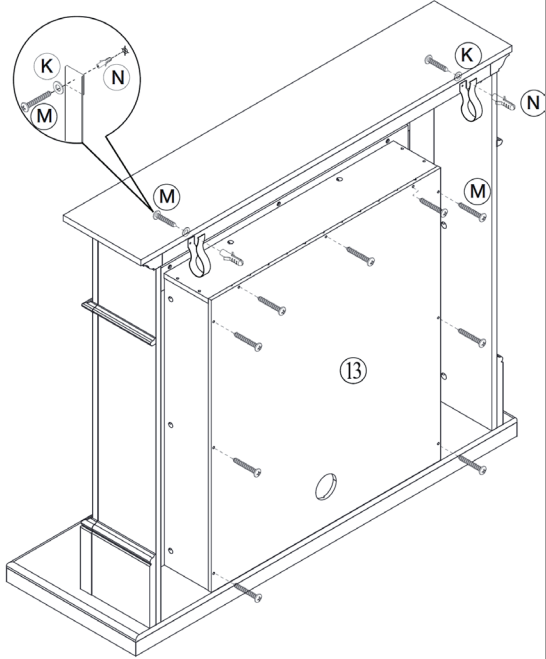

CLEANING AND CARE

Note: Turn off the unit and unplug it from the power outlet. Wait until the unit has completely cooled down before cleaning it.

- Use a vacuum cleaner to clean the ventilation slots and grilles.
- Remove dust on the outside surfaces with a damp (not wet) cloth.
- Do not use strong cleaning agents or abrasives.
- Do not spray the device with liquids or immerse it in water or other liquids.
- Never open the heater housing.

Storage

Keep the unit in a dust-free place during the low season. Pack it in the original carton. Wind the heater cable cleanly to avoid damaging the cable.

Estimado cliente:

Le felicitamos por la adquisición de este producto. Lea atentamente el siguiente manual y siga cuidadosamente las instrucciones de uso con el fin de evitar posibles daños. La empresa no se responsabiliza de los daños ocasionados por un uso indebido del producto o por haber desatendido las indicaciones de seguridad. Escanee el siguiente código QR para acceder al manual de usuario más reciente y a otra información sobre el producto:



ÍNDICE

Alcance del suministro 28
Herramientas necesarias 29
Lista de piezas 30
Montaje 31
Limpieza y cuidado 38

FABRICANTE

Chal-Tec GmbH, Wallstraße 16, 10179 Berlin, Alemania

ALCANCE DEL SUMINISTRO

① x 1

② x 1

③ x 1

④ x 1

⑤ x 1

⑥ x 2

⑦ x 1

⑧ x 1

⑨ x 1

⑩ x 1

⑪ x 2

⑫ x 1

⑬ x 1

⑭ x 1

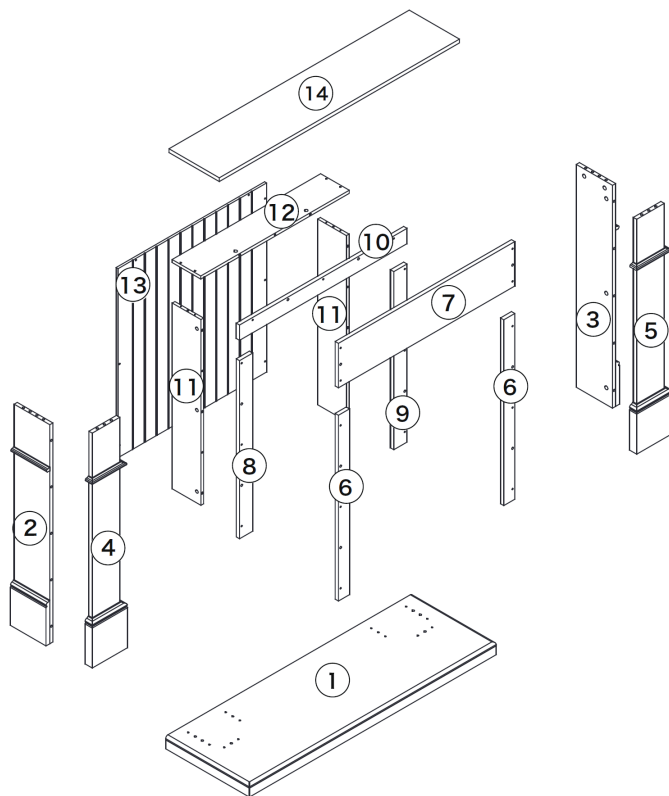

Nota: Busque un lugar donde la chimenea esté protegida de la luz solar directa.

HERRAMIENTAS NECESARIAS

Para la instalación se necesitan las siguientes herramientas:

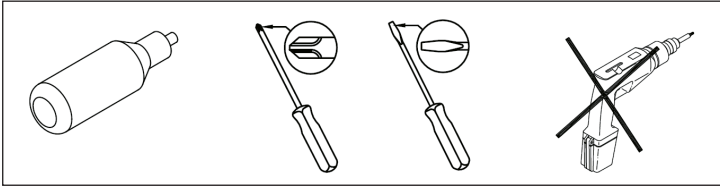

Nota: La cola para madera no está incluida en el alcance de suministro. Recomendamos que ponga un poco de cola para madera en los agujeros antes de insertar las clavijas de madera.



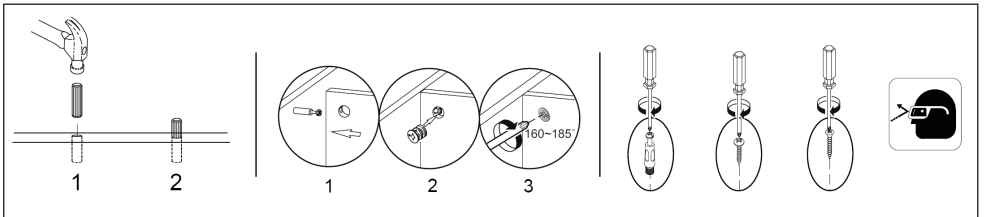









Utilice las herramientas como se indica a continuación:



Instrucciones importantes para la instalación

- Siga exactamente las instrucciones de instalación.
- Asegúrese de que la caja contiene todas las piezas.
- Para evitar daños en el producto, monte la carcasa sobre el cartón.
- Limpie la superficie de la carcasa sólo con un plumero o un paño húmedo, no utilice productos de limpieza abrasivos.

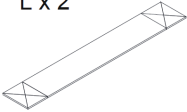
LISTA DE PIEZAS

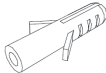
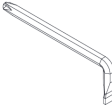
<p>A x 14</p> 	<p>B x 14</p> 	<p>C x 16</p>  <p>Φ7.8 X 30 mm</p>	<p>D x 12</p>  <p>Φ7.8 X 20 mm</p>
<p>E x 19</p>  <p>Ø4x24mm</p>	<p>F x 8</p> 	<p>G x 9</p>  <p>Φ5.8 X 30 mm</p>	<p>H x 16</p>  <p>Ø4x50mm</p>
<p>I x 8</p> 	<p>J x 2</p>  <p>Ø4x14mm</p>	<p>K x 4</p> 	<p>L x 2</p> 
<p>M x 11</p>  <p>Ø4x35mm</p>	<p>N x 2</p> 	<p>O x 1</p> 	

Nota: El uso de un tornillo incorrecto puede causar daños. Antes de comenzar el montaje, clasifique los distintos tipos de tornillos.

Tipos y longitudes de tornillos

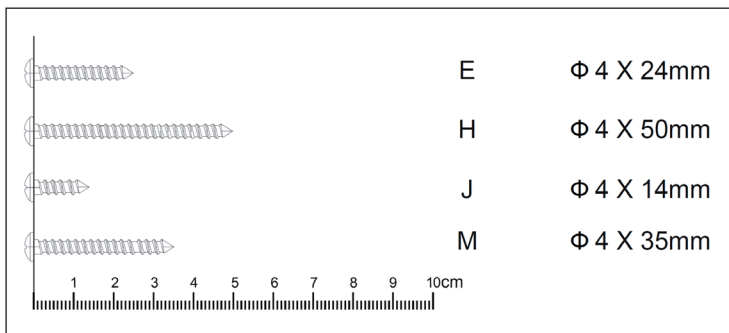

MONTAJE

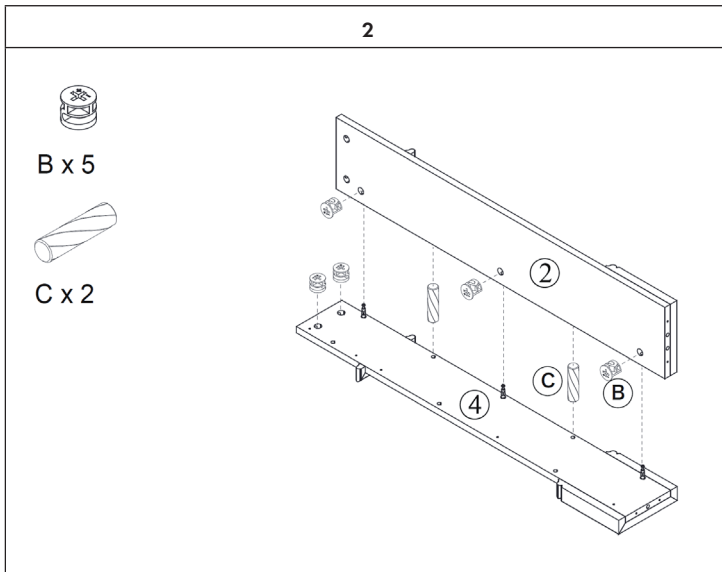
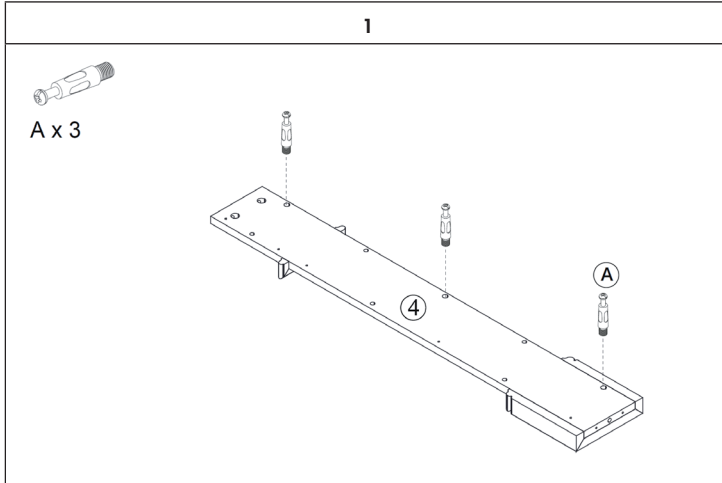

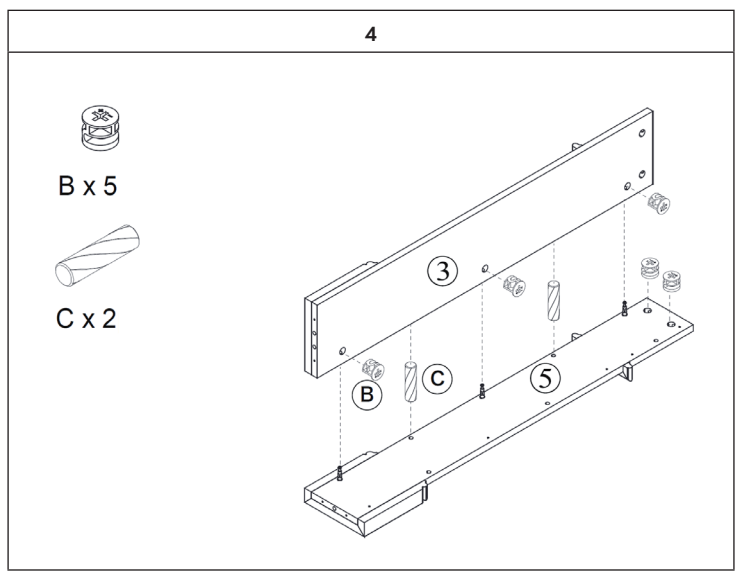
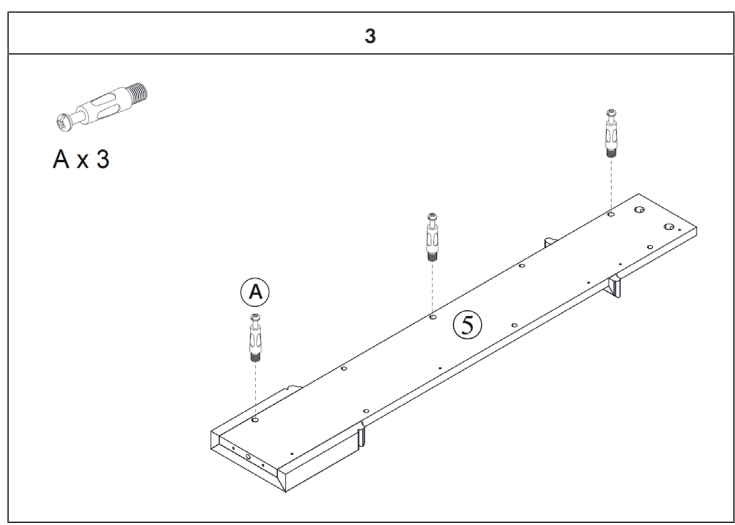

5

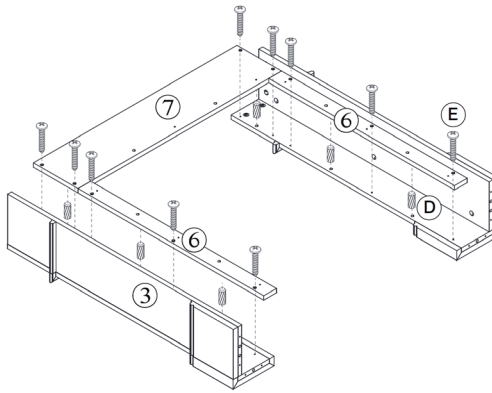
D x 6
E x 10

6

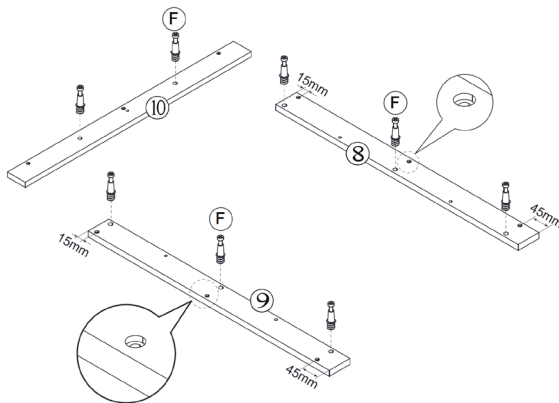
F x 8

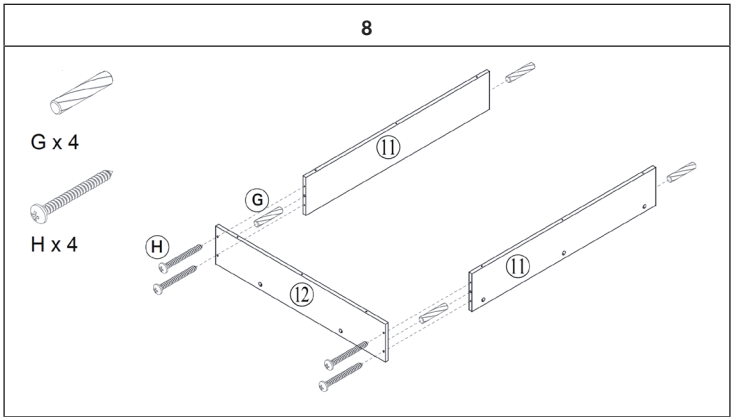
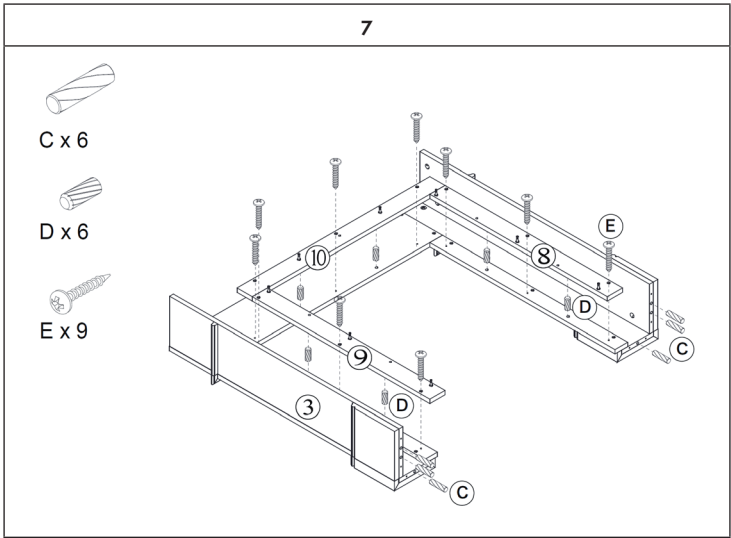

9



C x 6



G x 5



I x 8



O

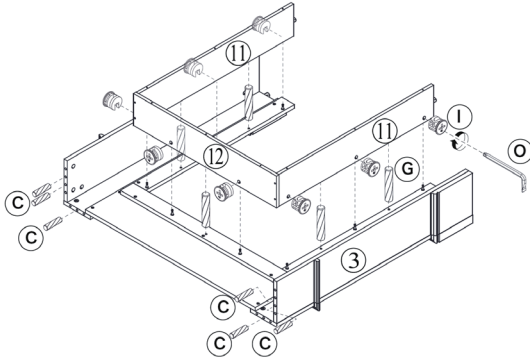

10



H x 12

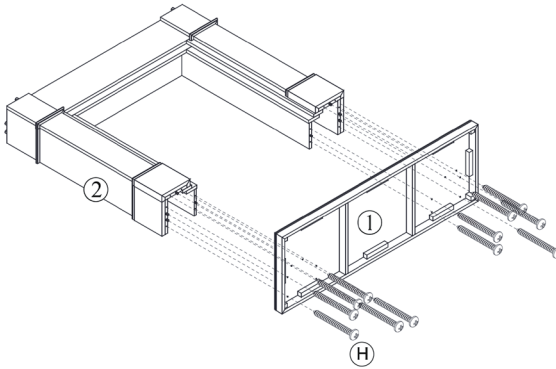

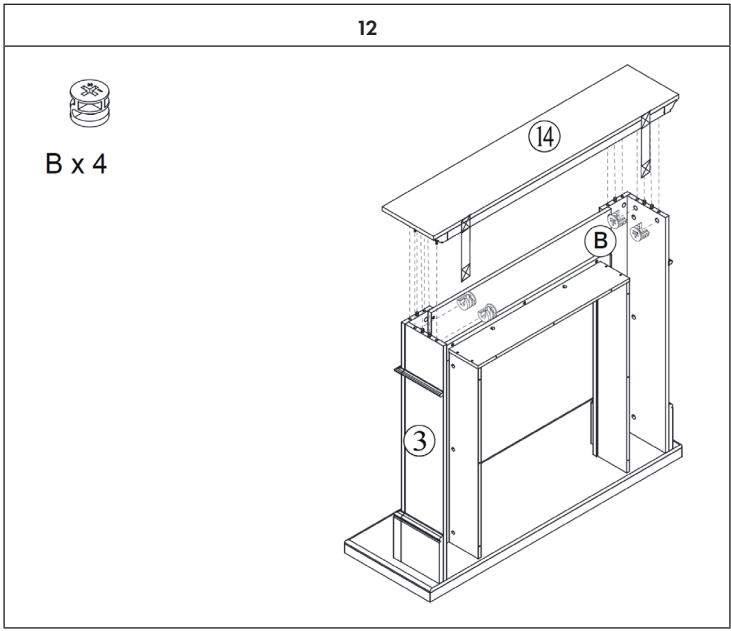
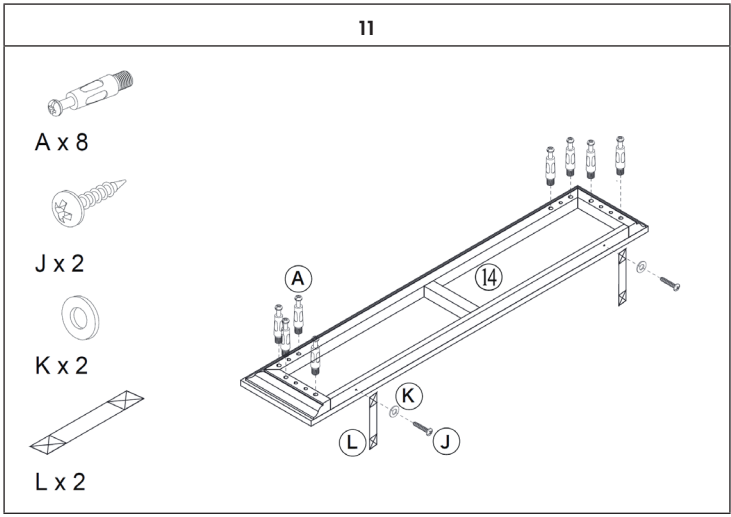

9



K x 2



M x 11



N x 2

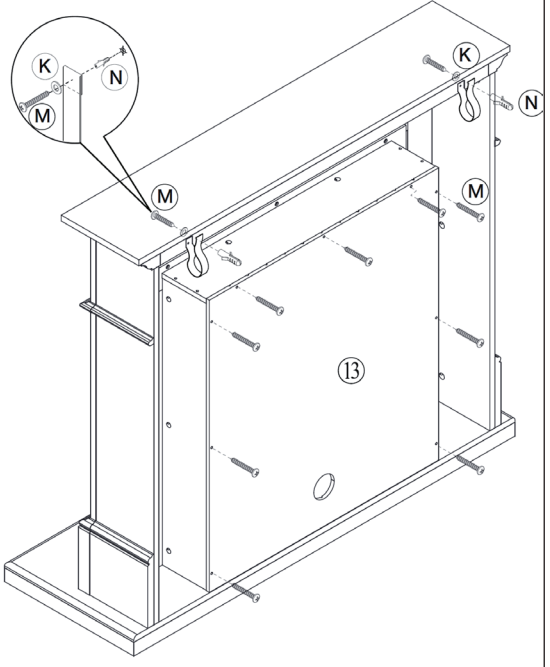

LIMPIEZA Y CUIDADO

Nota: Apague el aparato y desenchúfelo de la toma de corriente. Espere hasta que la unidad se haya enfriado completamente antes de limpiarla.

- Use una aspiradora para limpiar las ranuras de ventilación y las rejillas.
- Limpie el polvo de las superficies externas con un paño húmedo (no mojado).
- No utilice detergentes o abrasivos fuertes.
- No rocíe el aparato con líquidos y no lo sumerja en agua u otros líquidos.
- No abra nunca la carcasa del calentador.

Almacenamiento

Mantenga la unidad en un lugar libre de polvo durante la temporada baja. Idealmente, empaquétele en la caja original. Enrolle el cable del calentador con cuidado para evitar que se dañe.

Cher client,

Toutes nos félicitations pour l'acquisition de ce nouvel appareil. Veuillez lire attentivement les instructions suivantes de branchement et d'utilisation afin d'éviter d'éventuels dommages. Le fabricant ne saurait être tenu pour responsable des dommages dus au non-respect des consignes de sécurité et à la mauvaise utilisation de l'appareil. Scannez le QR-Code pour accéder à la dernière version du mode d'emploi et à d'autres informations concernant le produit:



SOMMAIRE

Contenu de l'emballage 40
Outils nécessaires 41
Liste des pièces 42
Assemblage 43
Nettoyage et entretien 50

FABRICANT

Chal-Tec GmbH, Wallstraße 16, 10179 Berlin, Allemagne.

CONTENU DE L'EMBALLAGE

① x 1

② x 1

③ x 1

④ x 1

⑤ x 1

⑥ x 2

⑦ x 1

⑧ x 1

⑨ x 1

⑩ x 1

⑪ x 2

⑫ x 1

⑬ x 1

⑭ x 1

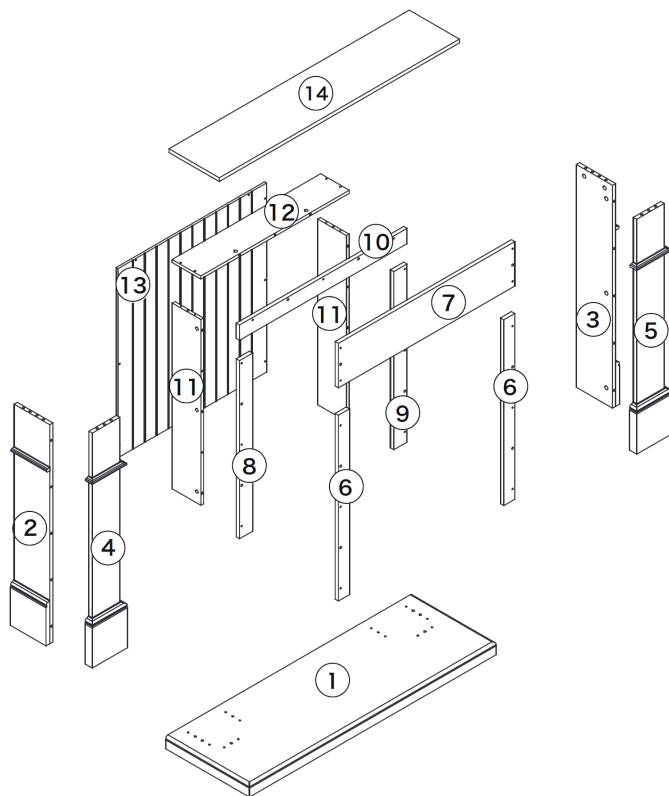

Remarque : recherchez un endroit où le foyer est protégé des rayons directs du soleil.

OUTILLAGE NÉCESSAIRE

Pour l'installation, vous aurez besoin des outils suivants :

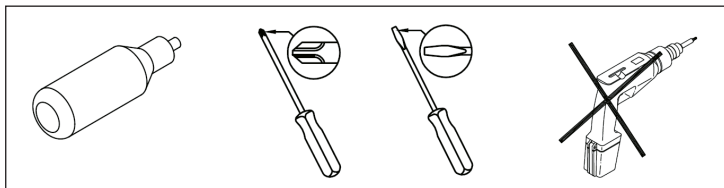

Remarque : La colle à bois n'est pas incluse. Nous vous recommandons de mettre de la colle à bois dans les trous avant d'insérer les chevilles en bois.



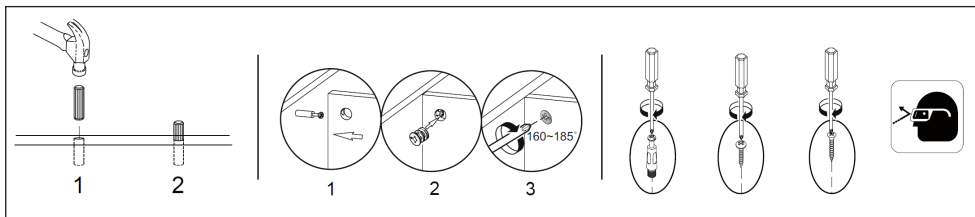









Utilisez les outils comme suit :

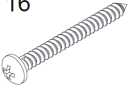

Informations importants pour l'installation



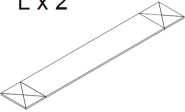

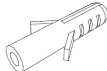
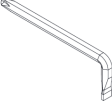
- Suivez les instructions de montage scrupuleusement.
- Assurez-vous que toutes les pièces sont incluses dans la boîte.
- Pour éviter d'endommager le produit, faites le montage du boîtier sur le carton.
- Nettoyez la surface du boîtier uniquement avec un plumeau ou un chiffon humide, ne pas utiliser de nettoyeurs abrasifs.

LISTE DES PIÈCES

A x 14 	B x 14 	C x 16  Φ7.8 X 30 mm	D x 12  Φ7.8 X 20 mm
E x 19  Ø4x24mm	F x 8 	G x 9  Φ5.8 X 30 mm	H x 16  Ø4x50mm
I x 8 	J x 2  Ø4x14mm	K x 4 	L x 2 
M x 11  Ø4x35mm	N x 2 	O x 1 	

Remarque: L'utilisation d'une mauvaise vis peut causer des dommages. Avant de commencer l'assemblage, trie les différents types de vis.

Types et longueurs de vis

	E	Φ 4 X 24mm
	H	Φ 4 X 50mm
	J	Φ 4 X 14mm
	M	Φ 4 X 35mm

1 2 3 4 5 6 7 8 9 10cm

ASSEMBLAGE

1



A x 3

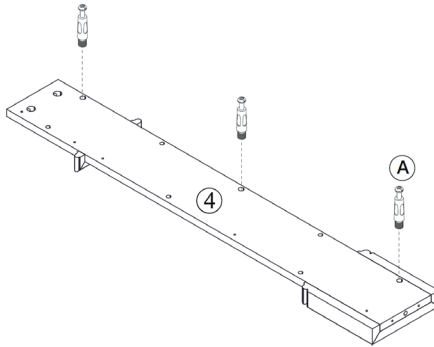

2



B x 5



C x 2

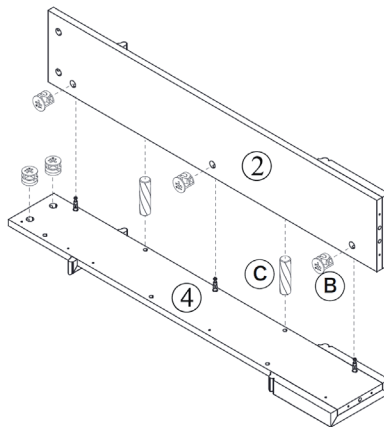

3



A x 3

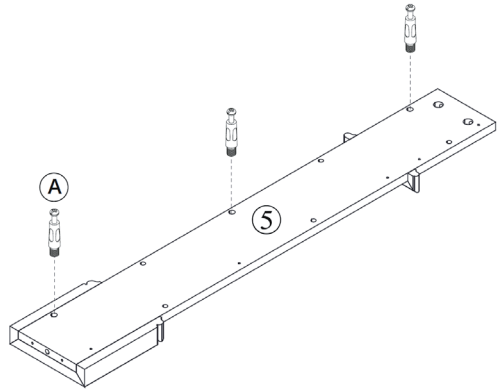

4



B x 5



C x 2

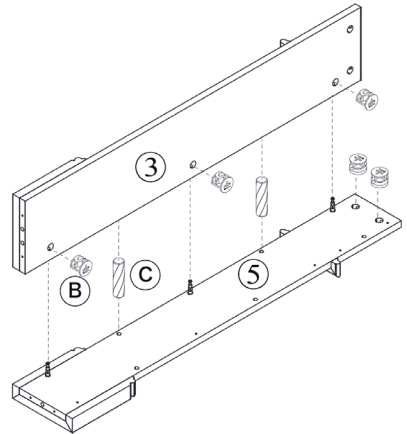

5



D x 6



E x 10

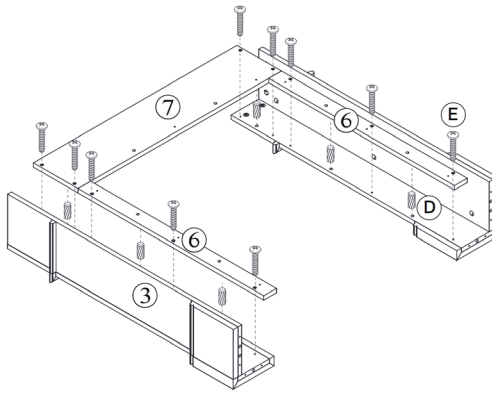

6



F x 8

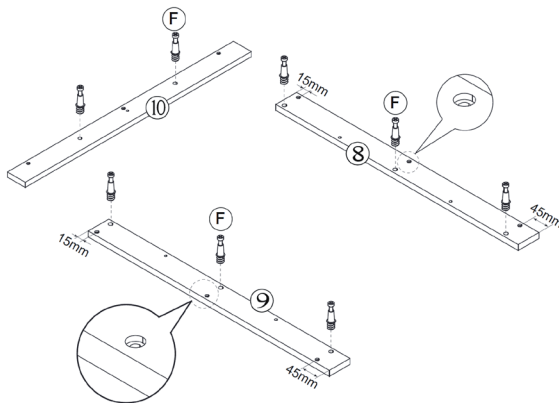

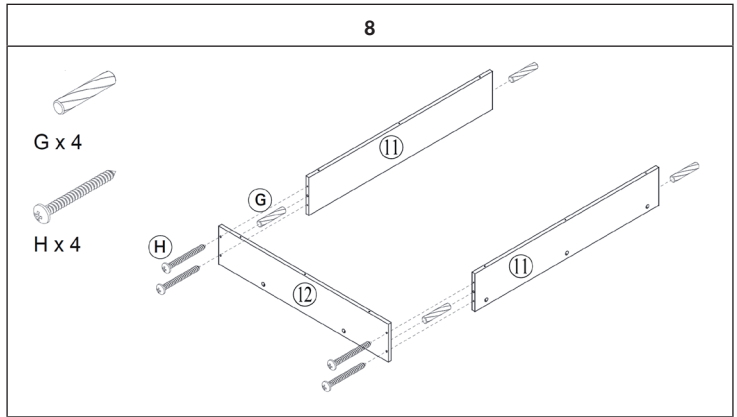
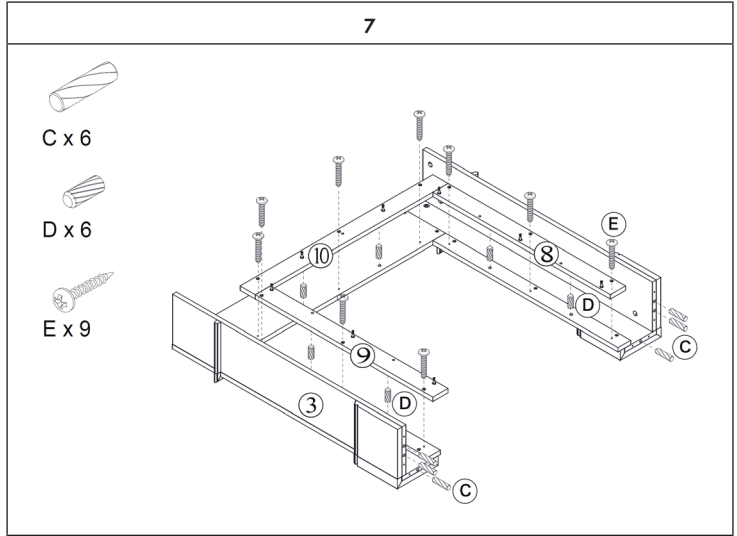

9



C x 6



G x 5



I x 8



O

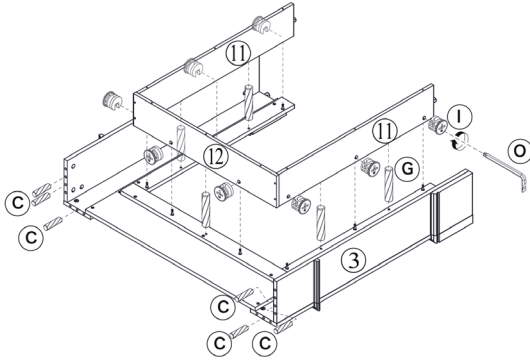

10



H x 12

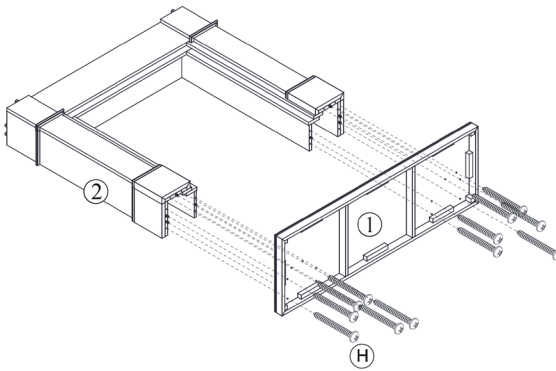

11



A x 8



J x 2



K x 2

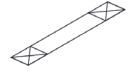

L x 2

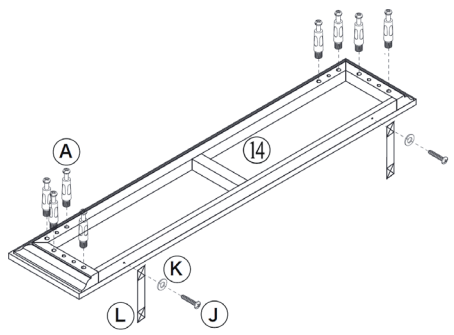

12



B x 4

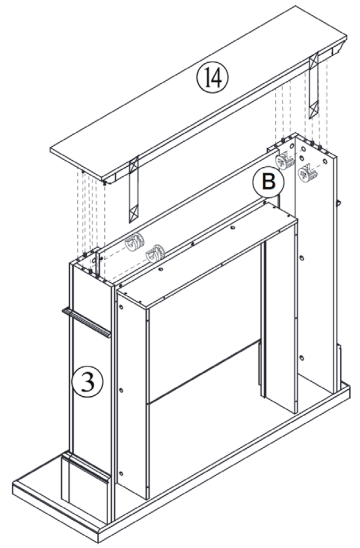

9



K x 2



M x 11



N x 2

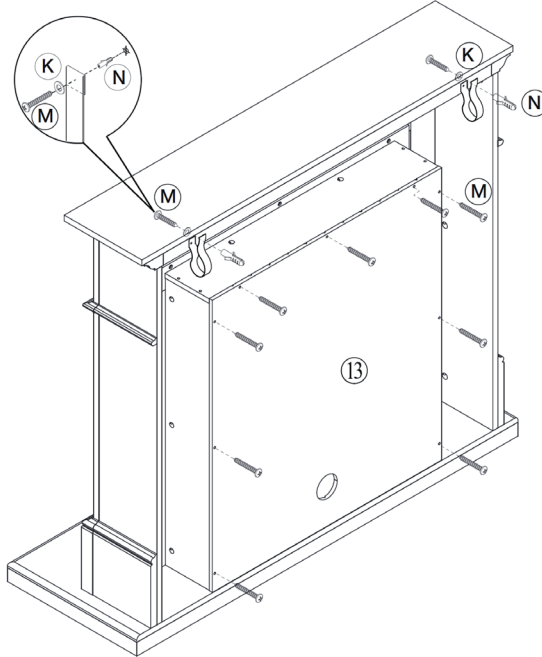

NETTOYAGE ET ENTRETIEN

Remarque : Éteignez l'appareil et débranchez la fiche de la prise. Attendez que l'appareil refroidisse complètement avant de le nettoyer.

- Utilisez un aspirateur pour nettoyer les ouvertures et les grilles.
- Retirez la poussière des surfaces extérieures avec un chiffon humide (non mouillé).
- N'utilisez pas de détergents agressifs ou d'abrasifs.
- Ne vaporisez pas l'appareil avec des liquides et ne le plongez pas dans l'eau ou d'autres liquides.
- N'ouvrez jamais le boîtier du radiateur.

Stockage

Hors saison, stockez l'appareil dans un endroit sans poussière. Idéalement, remettez-le dans son emballage d'origine. Enroulez le câble du radiateur soigneusement pour éviter de l'endommager.

Gentile cliente,

La ringraziamo per aver acquistato il dispositivo. La preghiamo di leggere attentamente le seguenti istruzioni per l'uso e di seguirle per evitare possibili danni tecnici. Non ci assumiamo alcuna responsabilità per danni scaturiti da una mancata osservazione delle avvertenze di sicurezza e da un uso improprio del dispositivo. Scansionare il codice QR seguente, per accedere al manuale d'uso più attuale e per ricevere informazioni sul prodotto.



INDICE

Volume di consegna 52
Utensili necessari 53
Lista dei componenti 54
Montaggio 55
Pulizia e manutenzione 62

PRODUTTORE

Chal-Tec GmbH, Wallstraße 16, 10179 Berlino, Germania.

VOLUME DI CONSEGNA

① x 1

② x 1

③ x 1

④ x 1

⑤ x 1

⑥ x 2

⑦ x 1

⑧ x 1

⑨ x 1

⑩ x 1

⑪ x 2

⑫ x 1

⑬ x 1

⑭ x 1

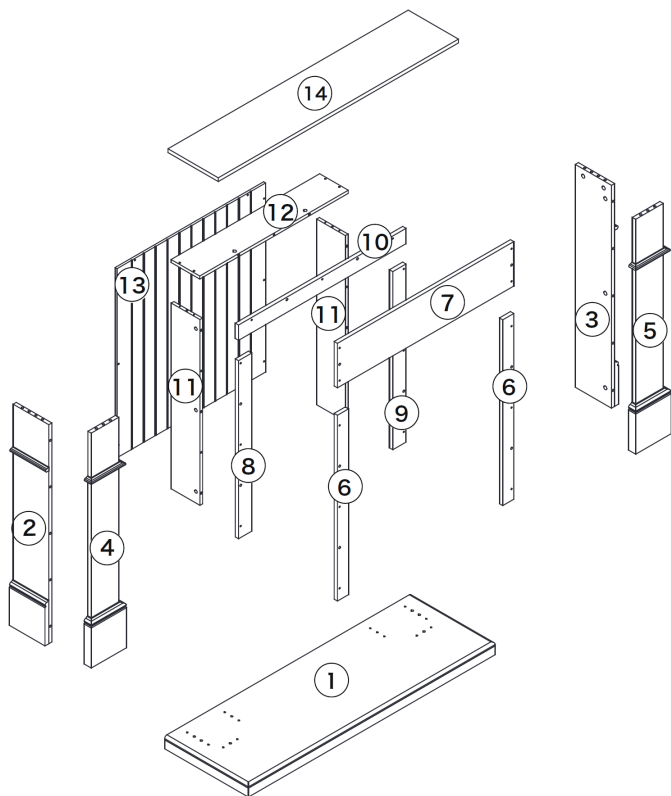

Avvertenza: cercare un luogo di posizionamento in cui il camino sia protetto dall'irraggiamento solare diretto.

UTENSILI NECESSARI

Per l'installazione sono necessari i seguenti utensili:

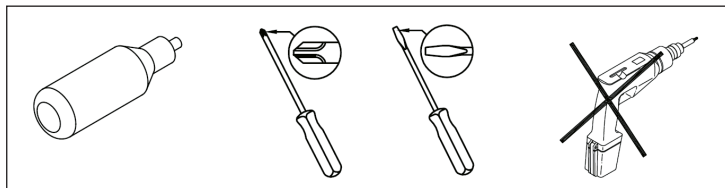

Avvertenza: la colla per legno non è inclusa in consegna. Consigliamo di mettere un po' di colla nei fori prima di inserire i tasselli.



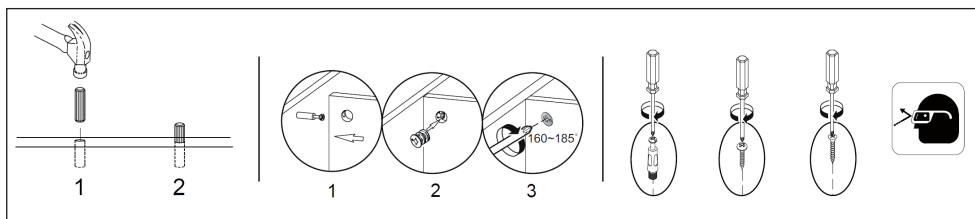









Utilizzare gli utensili come indicato di seguito:

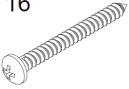

Avvertenze importanti sull'installazione



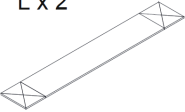

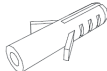
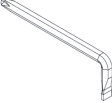
- Seguire attentamente le istruzioni di montaggio.
- Assicurarsi che nel cartone ci siano tutti i componenti.
- Per evitare danni al prodotto, montare l'alloggiamento sopra al cartone.
- Pulire la superficie dell'alloggiamento solo con un piumino o un panno umido, non utilizzare prodotti abrasivi.

LISTA DEI COMPONENTI

A x 14 	B x 14 	C x 16  Φ7.8 X 30 mm	D x 12  Φ7.8 X 20 mm
E x 19  Ø4x24mm	F x 8 	G x 9  Φ5.8 X 30 mm	H x 16  Ø4x50mm
I x 8 	J x 2  Ø4x14mm	K x 4 	L x 2 
M x 11  Ø4x35mm	N x 2 	O x 1 	

Avvertenza: l'utilizzo della vite sbagliata può causare danni. Prima di iniziare il montaggio, suddividere i diversi tipi di viti.

Tipologie e lunghezze delle viti

	E	Φ 4 X 24mm
	H	Φ 4 X 50mm
	J	Φ 4 X 14mm
	M	Φ 4 X 35mm

1 2 3 4 5 6 7 8 9 10cm

MONTAGGIO

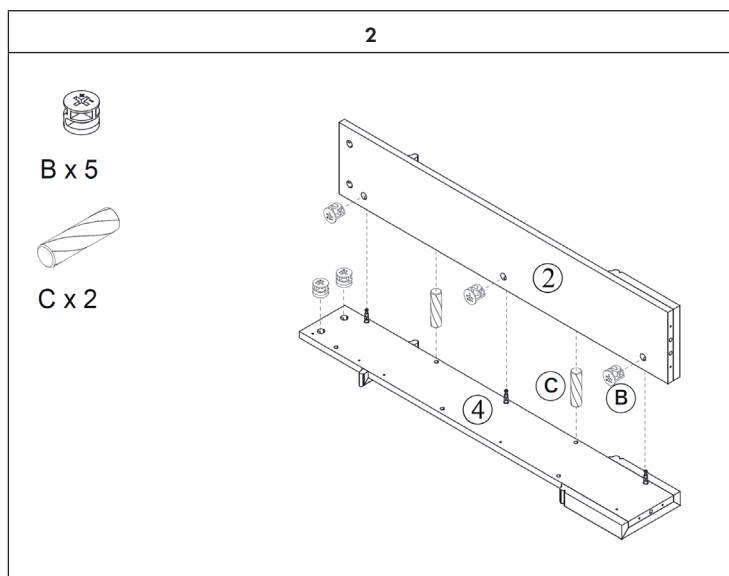
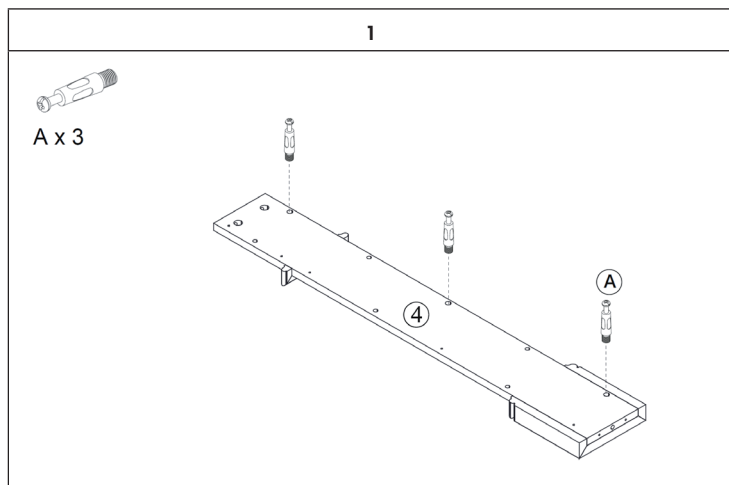

3

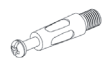

A x 3

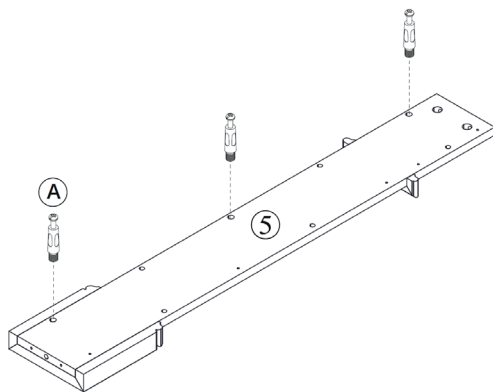

4



B x 5



C x 2

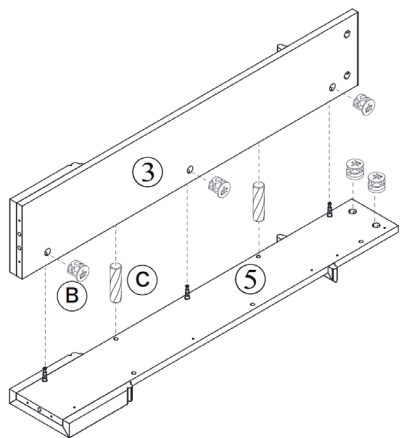

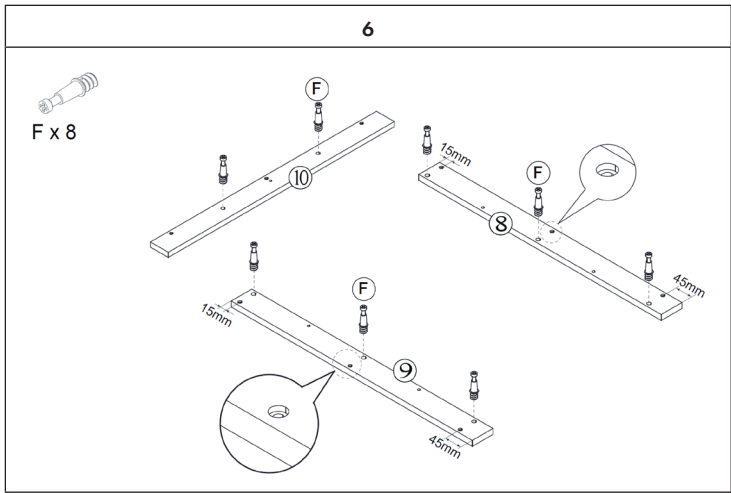
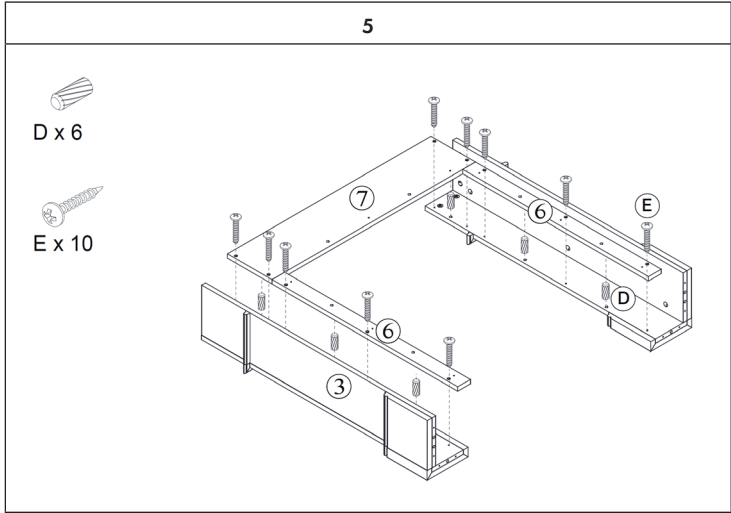

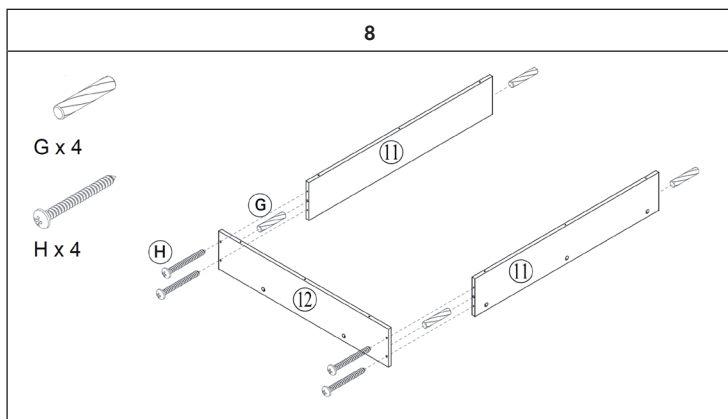
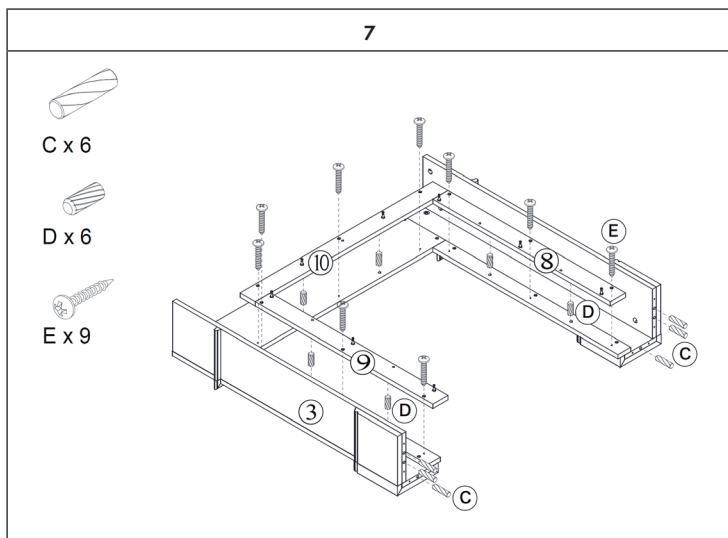

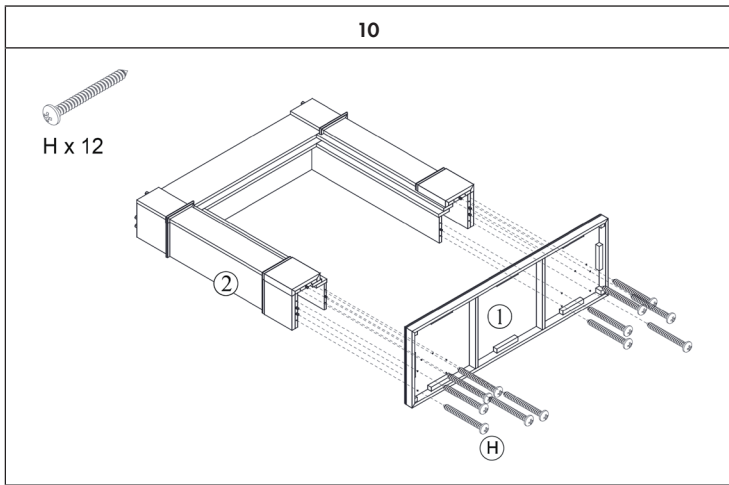
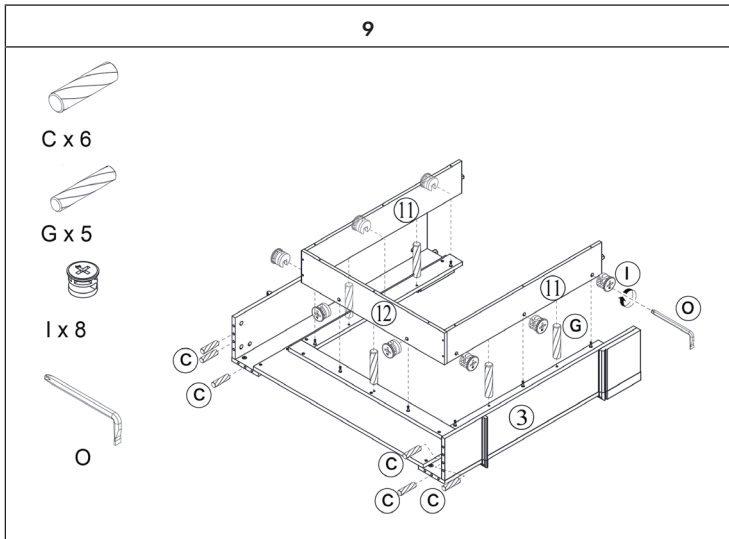

11



A x 8



J x 2



K x 2

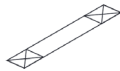

L x 2

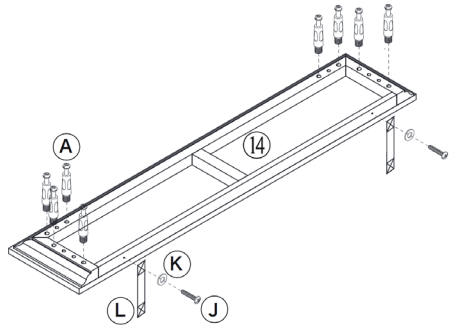

12



B x 4

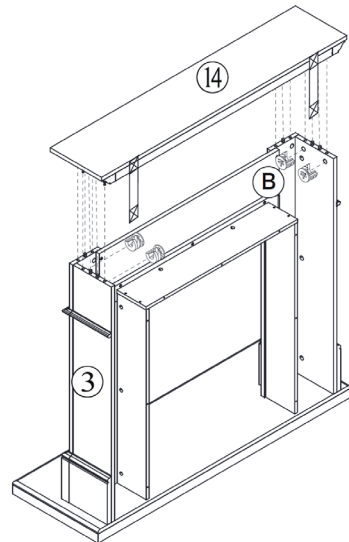

9



K x 2



M x 11



N x 2

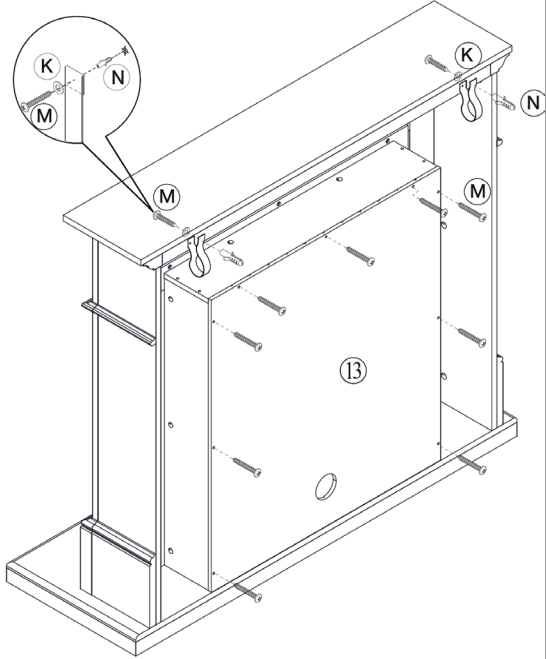

PULIZIA E MANUTENZIONE

Avvertenza: spegnere il dispositivo e staccare la spina. Attendere che il dispositivo sia completamente raffreddato prima di pulirlo.

- Utilizzare un aspirapolvere per pulire le aperture di ventilazione e la griglia.
- Rimuovere la polvere dalle superfici esterne con un panno umido (non bagnato).
- Non utilizzare detergenti aggressivi o abrasivi.
- Non spruzzare liquidi sul dispositivo e non immergerlo in acqua o altri liquidi.
- Non aprire mai l'alloggiamento del camino.

Stoccaggio

Durante la stagione estiva, conservare il camino in un luogo privo di polvere. Imballarlo nel cartone originale. Avvolgere in modo ordinato il cavo del camino, in modo da evitare danni.

KLARSTEIN NIETSRK

SRSRK KLARSTEIN NIE

KLARSTEIN NIETSRK

SRSRK KLARSTEIN NIE

KLARSTEIN NIETSRK

SRSRK KLARSTEIN NIE

KLARSTEIN NIETSRK