

10033497 10033498

Old Trafford

Tischfußball

Kicker Table

Table de babyfoot

Futbolín

Tavolo da calcetto

Sehr geehrter Kunde,

wir gratulieren Ihnen zum Erwerb Ihres Gerätes. Lesen Sie die folgenden Hinweise sorgfältig durch und befolgen Sie diese, um möglichen Schäden vorzubeugen. Für Schäden, die durch Missachtung der Hinweise und unsachgemäßen Gebrauch entstehen, übernehmen wir keine Haftung. Scannen Sie den folgenden QR-Code, um Zugriff auf die aktuellste Bedienungsanleitung und weitere Informationen rund um das Produkt zu erhalten.



INHALTSVERZEICHNIS

Artikel 3
 Konformitätserklärung 3
 Sicherheitshinweise 4
 Lieferumfang 5
 Montage 7
 Verwertung des Tischfußballspiels 12

ARTIKEL

Artikelnummer	10033497, 10033498
---------------	--------------------

KONFORMITÄTSERKLÄRUNG

Hersteller:

Chal-Tec GmbH, Wallstraße 16, 10179 Berlin,
 Deutschland.













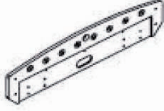
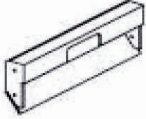

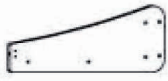

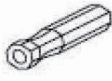

**Dieses Produkt entspricht den folgenden
 Europäischen Richtlinien:**

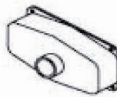
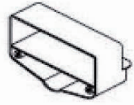
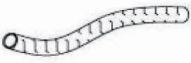



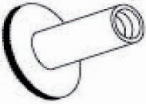



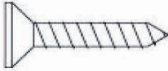
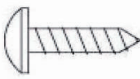
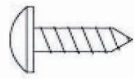

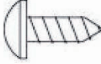





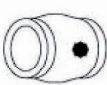

2009/48/EG

SICHERHEITSHINWEISE

- Die Montage sollte durch einen Erwachsenen erfolgen. Das zusammengebaute Tischfußballspiel ist in seinen Abmessungen relativ groß und könnte nicht gut durch Türen passen. Daher wird empfohlen, das Tischfußballspiel in dem Raum zusammenzubauen, in dem gespielt werden soll.
- Falls Sie den Spieltisch in einen anderen Raum transportieren möchten, müssen möglicherweise die Beine erst abmontiert und dann wieder angebracht werden.
- Dieser Kickertisch ist nur für die private Nutzung geeignet.
- Verwenden Sie dieses Gerät ausschließlich für den beabsichtigten Zweck.
- Beachten Sie bitte die folgenden Sicherheitshinweise, um eine lange Lebensdauer und optimale Funktionstüchtigkeit Ihres Tischfußballspiels zu gewährleisten:
- Den Kickertisch nicht im Freien stehen lassen. Regen, Schnee und hohe Luftfeuchtigkeit schaden dem Material. Auch eine längere Sonneneinstrahlung ist aufgrund der ausbleichenden Wirkung auf die Farben nicht zu empfehlen.
- Reinigen Sie den Tisch regelmäßig. Dabei genügt es, die Oberflächen mit einem feuchten Lappen abzuwischen, um Staub und andere Rückstände zu entfernen. Für eine gründlichere Reinigung kann man ein handelsübliches Reinigungsmittel verwenden, das weder Wachs noch ein Scheuermittel enthalten sollte. Bitte unbedingt darauf achten, dass alle Reinigungsmittelspuren restlos entfernt werden und die Oberflächen nicht nass bleiben. Um die Gleitfähigkeit der Spielerstangen zu erhöhen, wird empfohlen, ausschließlich ein hochwertiges Silikonspray zu verwenden. Es sollten möglichst keine Pflanzen- oder Mineralfette verwendet werden.
- Wenn Sie den Kickertisch an eine andere Person weitergeben, stellen Sie sicher, dass diese Person den Inhalt der Aufbau- und Bedienungsanleitung kennt.
- Stellen Sie diesen Tischkicker immer auf einen ebenen und festen Untergrund.
- Vor jeder Nutzung sollten Sie alle Teile auf Ihre Funktion überprüfen und bei nicht einwandfreier Nutzbarkeit diesen Tisch nicht benutzen.
- Verwenden Sie immer eine Unterlage (Pappe oder Teppich) unter den Tischbeinen des Gerätes zum Schutz Ihrer Einrichtung.
- **ACHTUNG:** Um Probleme bei der Montage bzw. Befestigung der Tischbeine zu vermeiden, schrauben Sie zunächst alle Tischbeine gleich an und abschließend alle fest.

LIEFERUMFANG

<p>P1 = 2x</p>  <p>Seitenteil P4B = 2x</p>	<p>P2 = 2x</p>  <p>Stirnseitenteil P5 = 2x</p>	<p>P3 = 1x</p>  <p>Spielfeld P6 = 8x</p>	<p>P4A = 2x</p>  <p>Tischbein links P7 = 3x</p>
 <p>Tischbein rechts P8A = 2x</p>	 <p>Blende Tischbein P8B = 2x</p>	 <p>Spielstangen-Griff P9 = 2x</p>	 <p>Unterstützende Querstrebe P10 = 2x</p>
 <p>Ball einwurf P11 = 2x</p>	 <p>Einwurfstützen P12 = 2x</p>	 <p>Ballfänger H1 = 24x</p>	 <p>Tor H2 = 24x</p>
 <p>Ballkanal H3 = 3x</p>	 <p>Torzähler H4 = 6x</p>	 <p>Sechskantschraube 5/16"</p>	 <p>Unterlegscheibe 5/16"</p>
 <p>Gewindestange H7 = 8x</p>	 <p>Hutmutter H8 = 8x</p>	 <p>Unterlegscheibe 3/8"</p>	 <p>Sechskantschraube 3/16"</p>
 <p>Unterlegscheibe 3/16"</p>	 <p>Flachkopfschraube 1"</p>	 <p>Rundkopfschraube 5/8"</p>	 <p>Rundkopfschraube 1/2"</p>

 H11 = 4x Rundkopfschraube 3/8" C3 = 2x	 H12 = 4x Höhenverstellbare Füße C4 = 16x	 C1 = 2x 5-Spieler-Stange C5 = 32x	 C2 = 4x 1+3-Spieler-Stange C6 = 26x
 C7 = 26x 2-Spieler-Stange C7 = 26x	 C8 = 11x / C9 = 11x Gummipuffer (Spielstange) C8 = 11x / C9 = 11x	 C10 = 4x Kunststoffunterlegscheibe C10 = 4x	 C11 = 16 Schraube für Spieler C11 = 16
 P13 = 4x Mutter für Spieler P13 = 4x	 P14 = 4x Spielerfigur P14 = 4x	 P15 = 4x Torstopper P15 = 4x	 A1 = 2x Lager A1 = 2x
 A2 = 1x Montageplatte für höhenverstellbare Füße A2 = 1x	 A3 = 2x Spielfeldecken A3 = 2x	 P16 = 8x Stopfen P16 = 8x	 A1 = 2x Ball A1 = 2x
 A2 = 1x Inbusschlüssel Klein A2 = 1x	 A3 = 2x Inbusschlüssel gross A3 = 2x	 P16 = 8x Endkappe P16 = 8x	

MONTAGE

Positionieren der Stangen

Jede Mannschaft besteht aus:

- dem Torwart (Stange mit 1 Spieler) am Ende des Spielfeldes Position A.
- den Abwehrspielern (Stange mit 2 Spielern) direkt vor dem Torwart der gleichen Farbe Position B.
- den Mittelfeldspielern (Stange mit 5 Spielern) in der Mitte des Spielfeldes unmittelbar gegenüber der Stange mit den 5 Spielern der gegnerischen Farbe Position C.
- den Stürmern (Stange mit 3 Spielern): in der Mitte des Spielfeldes vor der Stange mit den 2 Spielern der gegnerischen Farbe Position D.

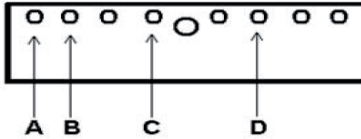

Griffseite
Loch

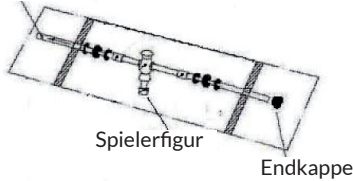

schwarzer
Torzähler



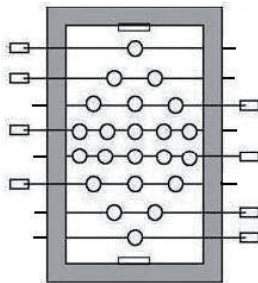



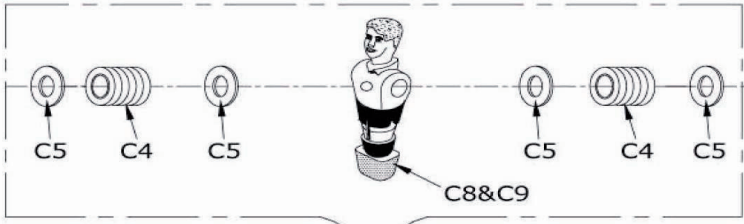

Seite der schwarzen
Mannschaft



Seite der weißen
Mannschaft

weißer
Torzähler



- | | | |
|---|------------------------------------|-----------|
|  | R1 5-Heimspieler-Stange | 1x |
|  | R2 3-Heimspieler-Stange | 1x |
|  | R3 2-Heimspieler-Stange | 1x |
|  | R4 1-Heimspieler-Stange | 1x |
|  | R5 5-Auswärtsspieler-Stange | 1x |
|  | R6 3-Auswärtsspieler-Stange | 1x |
|  | R7 2-Auswärtsspieler-Stange | 1x |
|  | R8 1-Auswärtsspieler-Stange | 1x |

Schritt 1

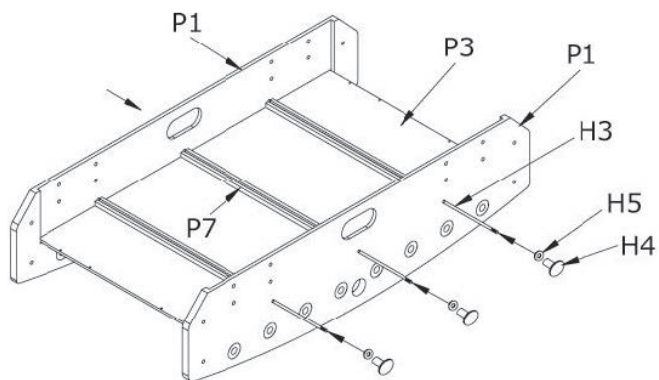

Schritt 2

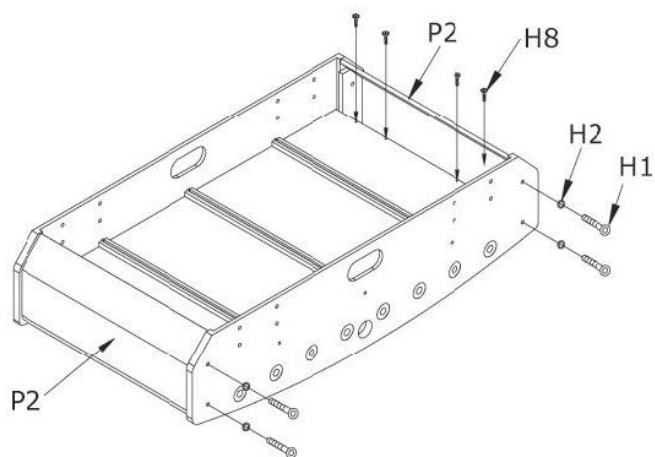

Schritt 3

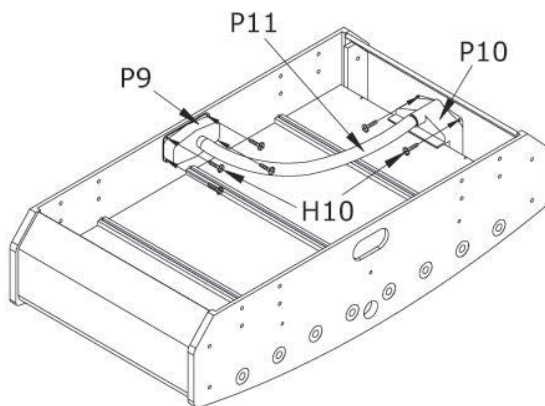

Schritt 4

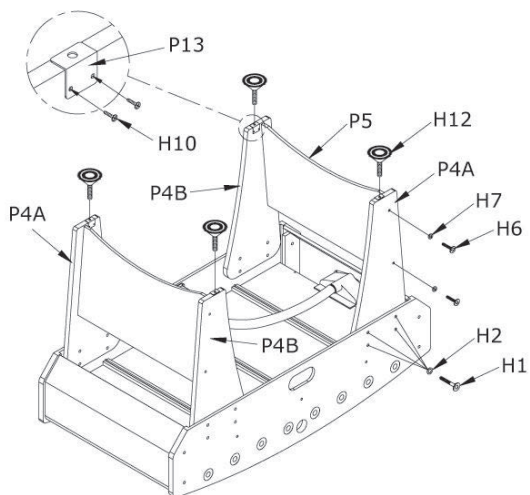

Schritt 5

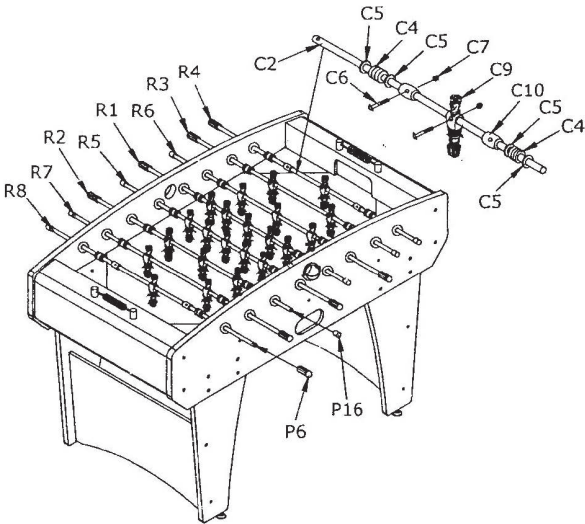
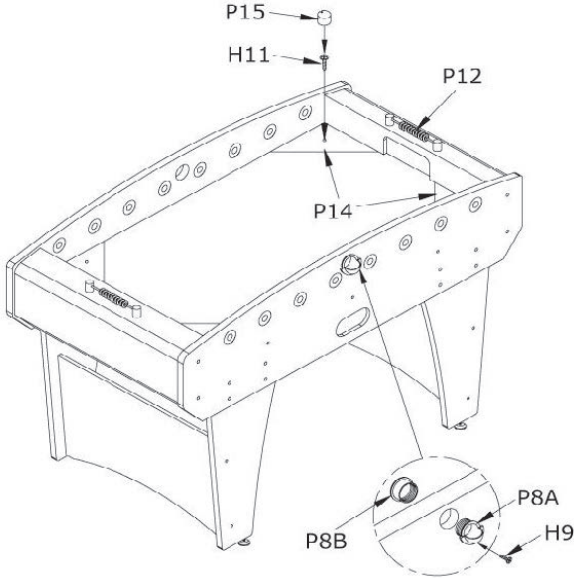

VERWERTUNG DES TISCHFUSSBALLSPIELS

Entsorgung

Die Entsorgung des Tischfußballspiels bedarf keiner besonderen Sorgfalt, da keinerlei Bauteile aus gefährlichen Materialien bestehen.

Die folgenden Materialien wurden zur Konstruktion verwendet: Holz, MDF, Stahl, Aluminium, ABS, PP, PE, PVC.

Diese Materialien sind insbesondere in den folgenden Bauteilen enthalten:

Rahmen: Holz, MDF, Stahl.

Beine: Holz, Stahl

Spielfläche: Holz

Stangen: Stahl, PP (Moplen)

Zubehör: ABS, PE, PVC.

Ausstattung: Aluminium, ABS.

Für die Entsorgung wird eine Sortierung je nach Materialart der einzelnen Bauteile sowie deren Abgabe an eigens dafür eingerichtete Sammel- bzw. Recyclingstellen empfohlen.

Dear Customer,

Congratulations on purchasing this equipment. Please read this manual carefully and take care of the following hints to avoid damages. Any failure caused by ignoring the items and cautions mentioned in the instruction manual are not covered by our warranty and any liability. Scan the QR code to get access to the latest user manual and other information about the product.



CONTENTS

Item 13
 Declaration of Conformity 13
 Safety Instructions 14
 Scope of Supply 15
 Setup 17
 Demolition 22

ITEM

Item number	10033497, 10033498
-------------	--------------------

DECLARATION OF CONFORMITY

Producer:

Chal-Tec GmbH, Wallstraße 16, 10179 Berlin,
 Deutschland.













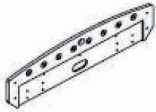
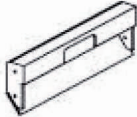

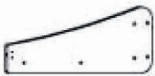



This product is conform to the following European Directives:

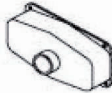
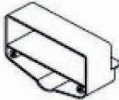

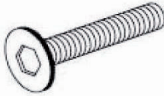

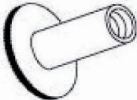

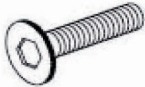

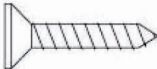
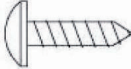
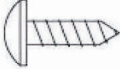







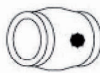

2009/48/EG

SAFETY INSTRUCTIONS

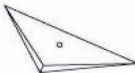
- **ASSEMBLY AND DISMANTLING MUST ONLY BE CARRIED OUT BY ADULTS.** Once assembled your table is quite wide and may not fit through your doors. For this reason you should assemble it in the room you intend it to be used. Should you wish to move your table to another room, it might be necessary to remove its legs.
- This table football set is only designed for private use. For commercial use, the warranty loses its validity. Please use this game exclusively for its intended purpose.
- Your table has been manufactured for indoor playing: do not leave it outdoors. Rain, snow and high humidity may damage its materials. Prolonged exposure to the sun is to be avoided too, due to its ultraviolet effects which will ruin the colours.
- Clean your table periodically. It is sufficient to wipe its surfaces using a damp cloth. For a deeper cleaning you can use any household detergent which does not contain wax or abrasives. Should you wish to further improve bars smoothness, only employ a good quality silicone spray. Please be careful not to use any vegetal or any other type of grease or you run the risk of attracting dirt.
- Should you pass on the table football set to another person, please make sure that this person is aware of the assembly and user instructions.
- Always place the table football set on even and stable surfaces.
- Before each use, check that all parts are working correctly and do not use the table football set if that is not the case.
- Always place a protective layer (cardboard or carpet) under the table legs to protect your floors.
- **CAUTION:** To avoid any problems in the assembly or fastening of the table legs, first screw on all legs loosely at the same time and only tighten them later.

SCOPE OF SUPPLY

<p>P1 = 2x</p>  <p>Side panel P4B = 2x</p>	<p>P2 = 2x</p>  <p>End panel P5 = 2x</p>	<p>P3 = 1x</p>  <p>Playfield P6 = 8x</p>	<p>P4A = 2x</p>  <p>Left leg P7 = 3x</p>
 <p>Right leg P8A = 2x</p>	 <p>Leg cover P8B = 2x</p>	 <p>Handle P9 = 2x</p>	 <p>Support brace P10 = 2x</p>
 <p>Outer ballentry P11 = 2x</p>	 <p>Inner ballentry P12 = 2x</p>	 <p>Ballcatcher H1 = 24x</p>	 <p>Goalbox H2 = 24x</p>
 <p>Balltube H3 = 3x</p>	 <p>Score counter H4 = 6x</p>	 <p>Hexagonscrew 5/16" H5 = 6x</p>	 <p>Washer 5/16" H6 = 8x</p>
 <p>Support rod H7 = 8x</p>	 <p>Nut H8 = 8x</p>	 <p>Washer 3/8" H9 = 2x</p>	 <p>Hexagonscrew 3/16" H10 = 20x</p>
 <p>Washer 3/16"</p>	 <p>Countersunk screw 1"</p>	 <p>Round-head screw 5/8"</p>	 <p>Round-head screw 1/2"</p>

<p>H11 = 4x</p>  <p>Round-head screw 3/8" C3 = 2x</p>	<p>H12 = 4x</p>  <p>Leg levellers C4 = 16x</p>	<p>C1 = 2x</p>  <p>5 players rod C5 = 32x</p>	<p>C2 = 4x</p>  <p>1 + 3 players rod C6 = 26x</p>
 <p>2 players rod C7 = 26x</p>	 <p>Shock absorber C8 = 11x / C9 = 11x</p>	 <p>Plastic washer C10 = 4x</p>	 <p>Screw for player C11 = 16</p>
 <p>Nut for player P13 = 4x</p>	 <p>Player P14 = 4x</p>	 <p>Goalie stopper P15 = 4x</p>	 <p>Bushing A1 = 2x</p>
 <p>Fixing plate for leg levellers A2 = 1x</p>	 <p>Playfieldcorners A3 = 2x</p>	 <p>Plug P16 = 8x</p>	 <p>Ball</p>
 <p>Allen key small</p>	 <p>Allen key big</p>	 <p>Endcap</p>	

SETUP

Position of rods

The football-table is equipped with 4 rods for each side/ team:

- Defence (2 players rod) in front of the same colour goalkeeper Position B
- Mid-fielder (5 players rod) in the middle of the playfield , in front of the 5 player rod of opposite colour Position C
- Forward (3 players rod) in front of the 2 players rod of opposite colour Position D

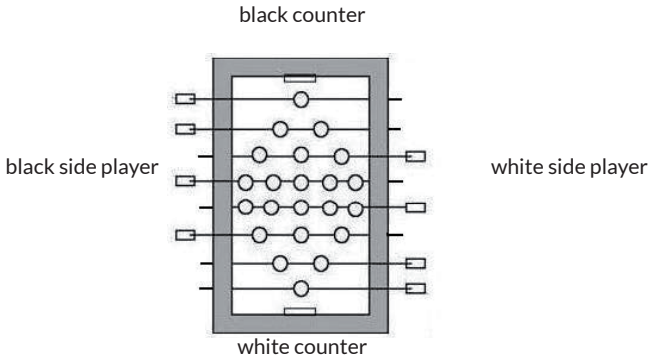
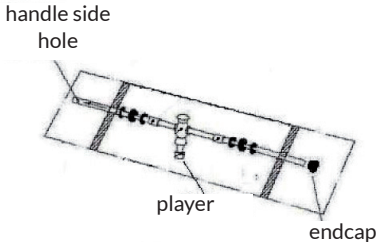
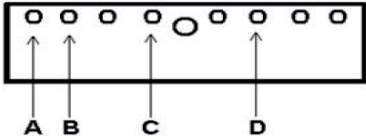

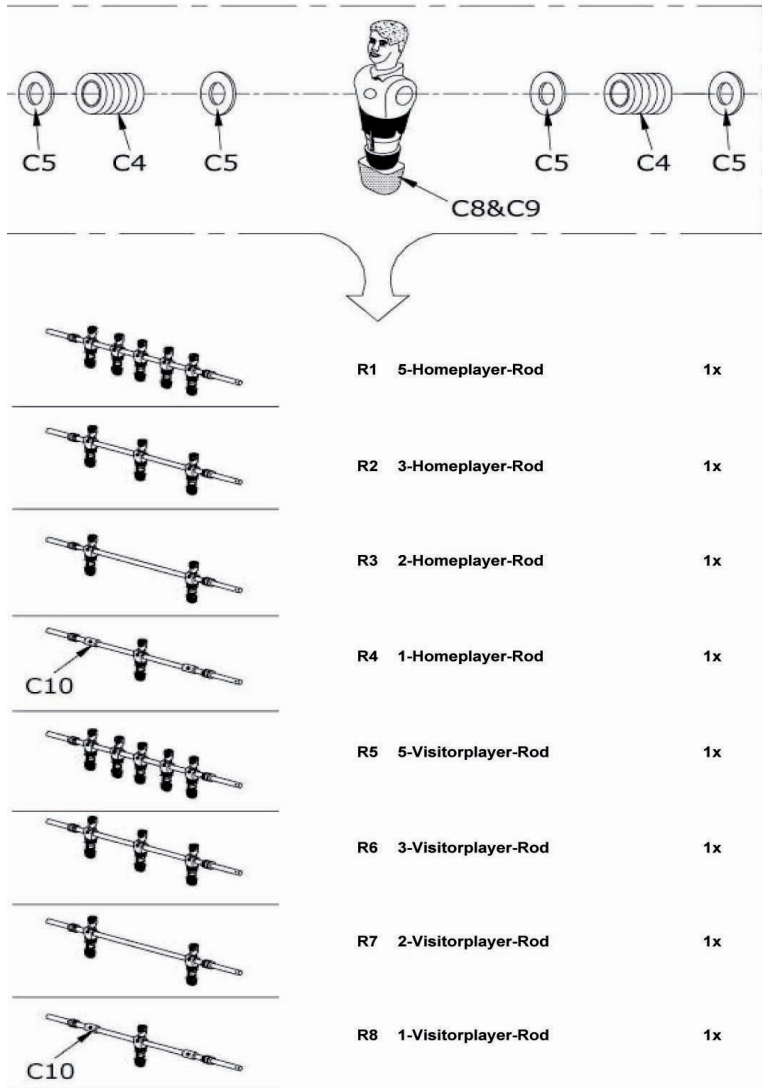

Step 1

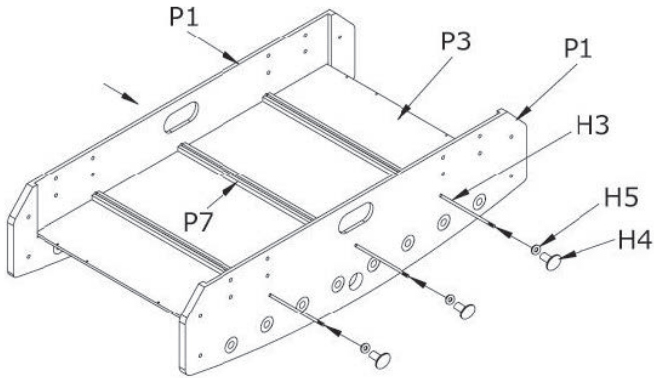

Step 2

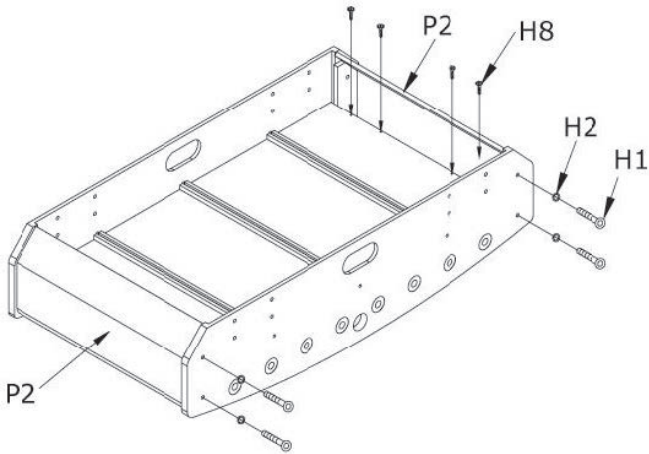

Step 3

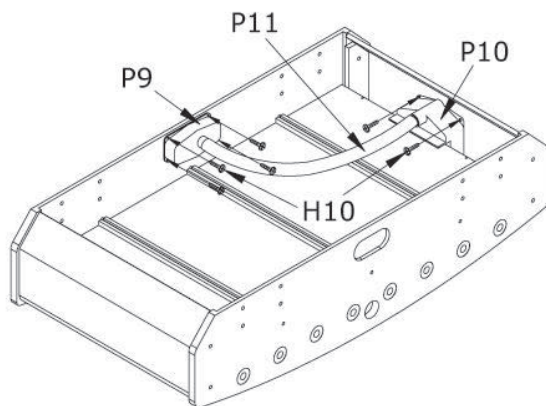

Step 4

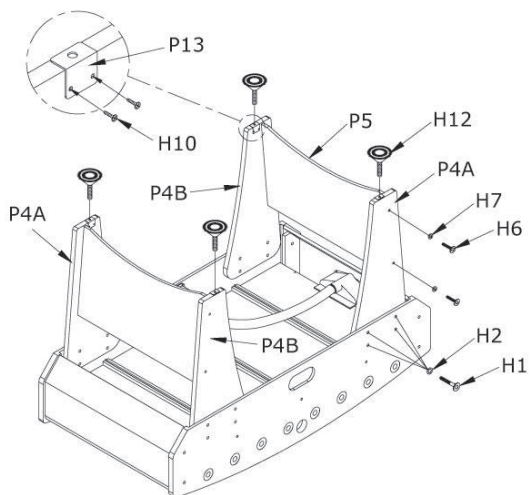

Step 5

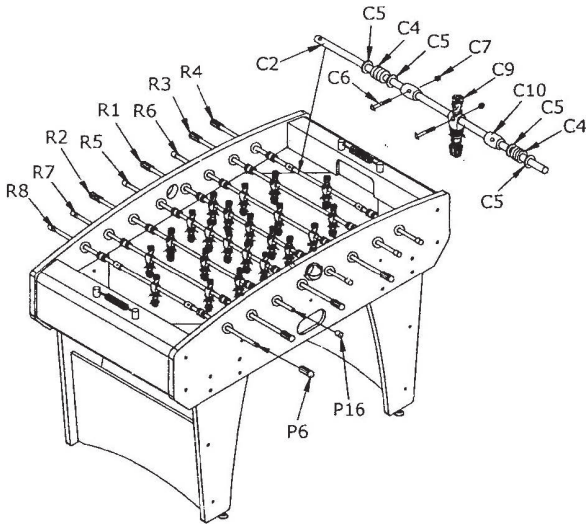
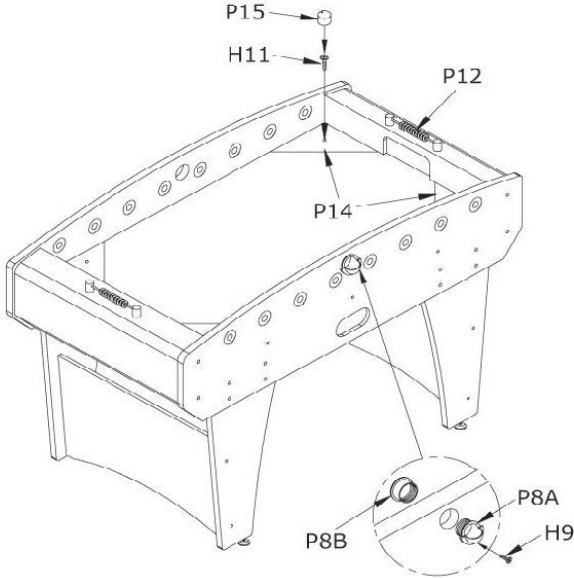

DEMOLITION

Demolition

The Soccer table doesn't require any particular care for the demolition since it doesn't have any parts produced with dangerous materials.

The materials are: Wood, MDF, Steel, Aluminium, ABS, PP, PE, PVC.

These materials are present in the following parts:

Frame:	Wood, MDF, Steel.
Legs:	Wood, Steel
Playfield:	Wood
Rods:	Steel, PP.
Accessories:	ABS, PE, PVC.
Finishing:	Aluminium, ABS.

During Soccer Table demolition we suggest the selection of the different materials and their removal in authorized collection centre for their recycling.

Removal of harmful materials: The Soccer Table doesn't produce any harmful substances.

Chère cliente, cher client,

Toutes nos félicitations pour l'acquisition de ce nouvel appareil. Veuillez lire attentivement et respecter les instructions de ce mode d'emploi afin d'éviter d'éventuels dommages. Nous ne saurions être tenus pour responsables des dommages dus au non-respect des consignes et à la mauvaise utilisation de l'appareil. Scannez le QR-Code pour obtenir la dernière version du mode d'emploi ainsi que d'autres informations concernant le produit.



SOMMAIRE

Article 23
 Déclaration de conformité 23
 Consignes de sécurité 24
 Contenu de l'emballage 25
 Assemblage 27
 Valorisation de la table de babyfoot 32

ARTICLE

Numéro d'article	10033497, 10033498
------------------	--------------------

DÉCLARATION DE CONFORMITÉ

Fabricant :
 Chal-Tec GmbH, Wallstraße 16, 10179 Berlin,
 Allemagne.











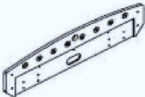
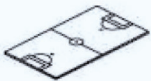



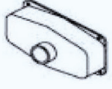

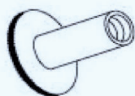
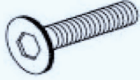

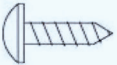

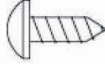







Ce produit est conforme aux directives européennes suivantes :
 2009/48/CE

CONSIGNES DE SÉCURITÉ

- L'assemblage doit être effectué par un adulte. Le babyfoot assemblé est de taille relativement importante et ne peut pas passer par les portes. Il est donc recommandé d'assembler le babyfoot dans la pièce où vous souhaitez jouer.
- Si vous souhaitez déplacer la table de jeu dans une autre pièce, vous devrez peut-être démonter les pieds puis les remonter.
- Ce babyfoot ne convient qu'à un usage privé.
- N'utilisez cet appareil que pour l'usage auquel il est destiné.
- Veuillez noter les consignes de sécurité suivantes pour assurer une longue durée de vie et une fonctionnalité optimale de votre babyfoot :
- Ne laissez pas le babyfoot à l'extérieur. La pluie, la neige et une humidité élevée endommagent le matériau. Une exposition prolongée au soleil n'est pas non plus recommandée en raison de la décoloration possible de la peinture.
- Nettoyez régulièrement le babyfoot. Il suffit d'essuyer les surfaces avec un chiffon humide pour éliminer la poussière et autres résidus. Pour un nettoyage plus approfondi, vous pouvez utiliser un produit de nettoyage du commerce qui ne doit pas contenir de cire ou d'abrasif. Assurez-vous que toutes les traces de détergent sont complètement éliminées et que les surfaces ne restent pas humides. Pour augmenter la capacité de glissement des barres de joueur, il est recommandé d'utiliser uniquement un spray silicone de haute qualité. Si possible, n'utilisez aucune graisse végétale ou minérale.
- Si vous transmettez le babyfoot à une autre personne, assurez-vous qu'elle a eu connaissance des instructions de montage et d'utilisation.
- Placez toujours cette table de babyfoot sur une surface plane et ferme.
- Avant chaque utilisation, vérifiez le bon fonctionnement de toutes les pièces et si elles ne sont pas parfaitement fonctionnelles, n'utilisez pas ce babyfoot.
- Utilisez toujours un tapis (carton ou tapis) sous les pieds de la table de l'appareil pour protéger votre intérieur.
- **ATTENTION** : Pour éviter les problèmes d'assemblage ou de fixation des pieds de table, vissez d'abord tous les pieds de table en même temps puis serrez-les tous.

CONTENU DE L'EMBALLAGE

<p>P1 = 2x</p>  <p>Bordure</p>	<p>P2 = 2x</p>  <p>Bordure frontale</p>	<p>P3 = 1x</p>  <p>Terrain de jeu</p>	<p>P4A = 2x</p>  <p>Pied gauche</p>
<p>P4B = 2x</p>  <p>Pied droit</p>	<p>P5 = 2x</p>  <p>Panneau des pieds</p>	<p>P6 = 8x</p>  <p>Poignée de barre de jeu</p>	<p>P7 = 3x</p>  <p>Entretoise transversale soutien</p>
<p>P8A = 2x</p>  <p>Mise en jeu de la balle</p>	<p>P8B = 2x</p>  <p>Support de mise en jeu de balle</p>	<p>P9 = 2x</p>  <p>Récupérateur de balle</p>	<p>P10 = 2x</p>  <p>But</p>
<p>P11 = 2x</p>  <p>Canal de balle</p>	<p>P12 = 2x</p>  <p>Compteur de points</p>	<p>H1 = 24x</p>  <p>Vis Allen</p>	<p>H2 = 24x</p>  <p>Rondelle</p>
<p>H3 = 3x</p>  <p>Barre fileté</p>	<p>H4 = 6x</p>  <p>Ecroû borgne</p>	<p>H5 = 6x</p>  <p>Vis à tête plate</p>	<p>H6 = 8x</p>  <p>Vis à tête ronde</p>
<p>H7 = 8x</p>  <p>Rondelle</p>	<p>H8 = 8x</p>  <p>Vis à tête plate</p>	<p>H9 = 2x</p>  <p>Vis à tête ronde</p>	<p>H10 = 20x</p>  <p>Vis à tête ronde</p>

<p>H11 = 4x</p>  <p>Vis à tête ronde 3/8"</p>	<p>H12 = 4x</p>  <p>Pieds réglables en hauteur</p>	<p>C1 = 2x</p>  <p>Barre à 5 joueurs</p>	<p>C2 = 4x</p>  <p>Barre à 1+3 joueurs</p>
<p>C3 = 2x</p>  <p>Barre à 2 joueurs</p>	<p>C4 = 16x</p>  <p>Tampon en caoutchouc</p>	<p>C5 = 32x</p>  <p>Rondelle en plastique</p>	<p>C6 = 26x</p>  <p>Vis de joueur</p>
<p>C7 = 26x</p>  <p>Ecrou de joueur</p>	<p>C8 = 11x / C9 = 11x</p>  <p>Figurine de joueur</p>	<p>C10 = 4x</p>  <p>Butée de barre de gardien de but</p>	<p>C11 = 16</p>  <p>Roulement</p>
<p>P13 = 4x</p>  <p>Platine de montage pour pieds réglables en hauteur</p>	<p>P14 = 4x</p>  <p>Coins du terrain de jeu</p>	<p>P15 = 4x</p>  <p>Bouchon</p>	<p>A1 = 2x</p>  <p>Balle</p>
<p>A2 = 1x</p>  <p>Petite clé Allen</p>	<p>A3 = 2x</p>  <p>Grande clé Allen</p>	<p>P16 = 8x</p>  <p>Embout</p>	

ASSEMBLAGE

Mise en place des barres

Chaque équipe se compose de :

- Un gardien de but (barre avec 1 joueur) à l'extrémité du terrain de jeu en position A.
- Deux défenseurs (barre à 2 joueurs) directement devant le gardien de but de même couleur en position B.
- Cinq milieux de terrain (barre à 5 joueurs) au milieu du terrain directement en face de la barre à 5 joueurs de la couleur adverse en position C.
- Trois attaquants (barre à 3 joueurs) : au milieu du terrain devant la barre à 2 joueurs de la couleur adverse en position D.

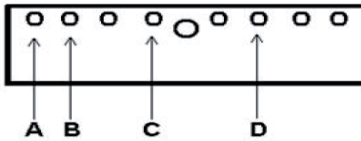

Trou latéral
de poignée

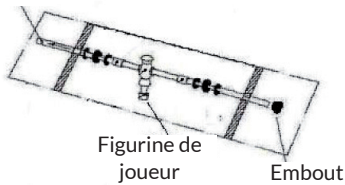

Figurine de
joueur

Embout

Compteur de
but noir

Côté de l'équipe
noire

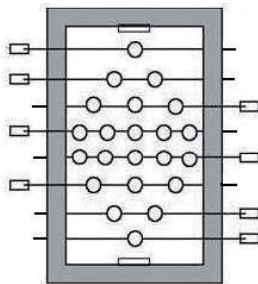

Côté de l'équipe
blanche

Compteur de
but blanc

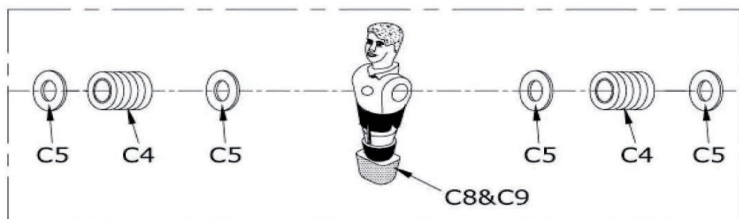

R1 - Barre de 5 joueurs à domicile

1x



R2 - Barre de 3 joueurs à domicile

1x



R3 - Barre de 2 joueurs à domicile

1x



R4 - Barre de 1 joueurs à domicile

1x



R5 - Barre de 5 joueurs à l'extérieur

1x

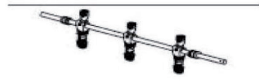

R6 - Barre de 3 joueurs à l'extérieur

1x



R7 - Barre de 3 joueurs à l'extérieur

1x

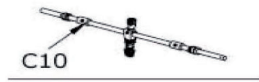

R8 - Barre de 1 joueurs à l'extérieur

1x

Étape 1

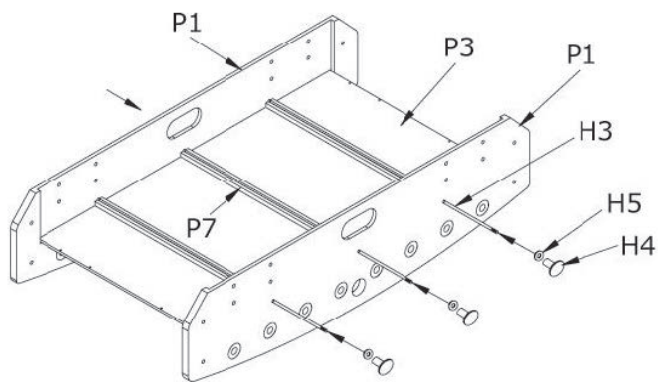

Étape 2

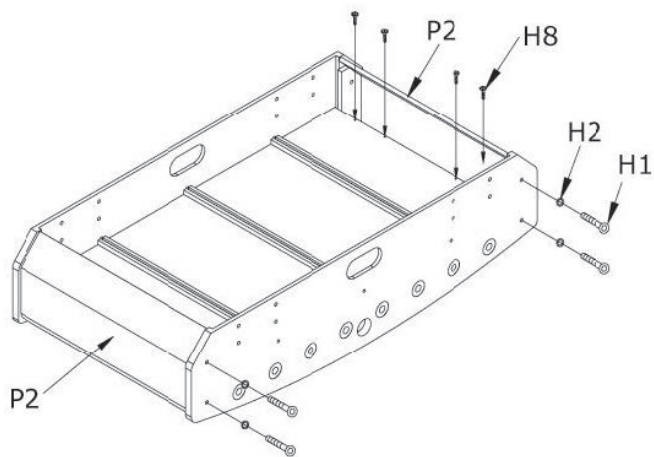

Étape 3

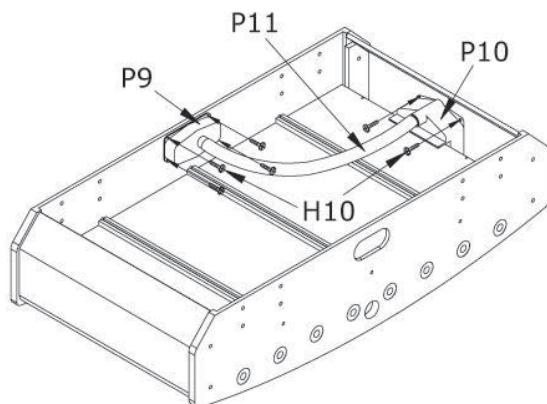

Étape 4

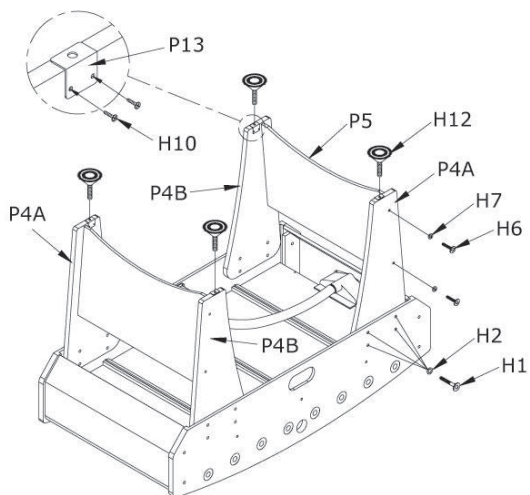

Étape 5

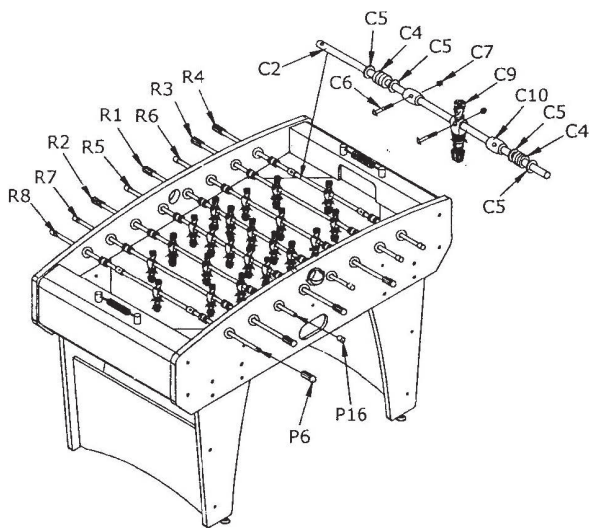
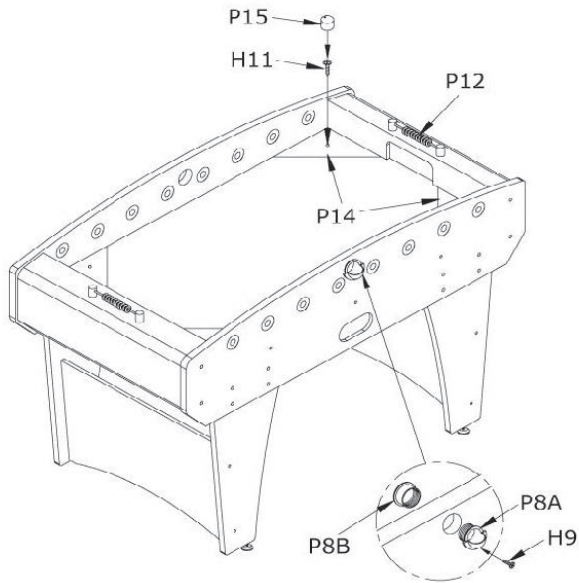

VALORISATION DE LA TABLE DE BABYFOOT

Recyclage

Le recyclage du babyfoot ne nécessite aucun soin particulier, car aucun élément ne contient de matériaux dangereux.

Les matériaux suivants ont été utilisés dans la construction : bois, MDF, acier, aluminium, ABS, PP, PE, PVC.

Ces matériaux se trouvent principalement dans les composants suivants :

Cadre : bois, MDF, acier.

Pieds : bois, acier

Surface de jeu : bois

Barres : acier, PP (Moplen)

Accessoires : ABS, PE, PVC.

Équipement : aluminium, ABS.

Pour le recyclage, il est recommandé d'effectuer un tri selon le type de matériau des éléments individuels et de les livrer aux points de collecte ou de recyclage spécialement aménagés à cet effet.

Estimado cliente,

Le felicitamos por la adquisición de este producto. Lea atentamente el siguiente manual y siga cuidadosamente las instrucciones de uso con el fin de evitar posibles daños. La empresa no se responsabiliza de los daños ocasionados por un uso indebido del producto o por haber desatendido las indicaciones de seguridad. Escanee el siguiente código QR para obtener acceso a la última guía del usuario y más información sobre el producto.



ÍNDICE

Artículo 33
 Declaración de conformidad 33
 Instrucciones de seguridad 34
 Alcance del suministro 35
 Montaje 37
 Indicaciones sobre la retirada del fútbolín 42

ARTÍCULO

Número d'article	10033497, 10033498
------------------	--------------------

DECLARACIÓN DE CONFORMIDAD

Fabricante :
 Chal-Tec GmbH, Wallstraße 16, 10179 Berlín,
 Alemania.











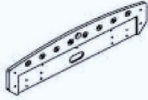

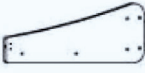

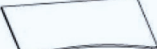
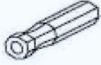



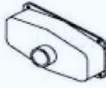
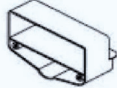

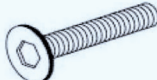



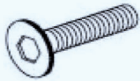

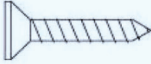

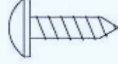

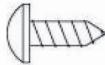







Este producto cumple con las siguientes directivas europeas :
 2009/48/CE

INSTRUCCIONES DE SEGURIDAD

- El montaje debe ser realizado por un adulto. El juego de fútbolín ensamblado es relativamente grande y puede no caber bien a través de las puertas. Por lo tanto, se recomienda que el juego de fútbolín se monte en la sala donde se va a jugar.
- Si desea mover la mesa a otra habitación, puede que sea necesario retirar las patas y volver a colocarlas.
- Este fútbolín sólo es apto para uso privado.
- Use esta unidad sólo para su propósito.
- Por favor, observe las siguientes instrucciones de seguridad para asegurar una larga vida útil y una óptima funcionalidad de su fútbolín:
- No dejes el fútbolín fuera. La lluvia, la nieve y la alta humedad dañarán el material. Ni siquiera se recomienda una exposición prolongada a la luz solar debido al efecto blanqueador de los colores.
- Limpia la mesa regularmente. Es suficiente limpiar las superficies con un paño húmedo para eliminar el polvo y otros residuos. Para una limpieza más profunda, puede utilizar un agente limpiador comercial que no debe contener cera o un limpiador abrasivo. Por favor, asegúrese de que todos los rastros de agente de limpieza se eliminan por completo y que las superficies no permanezcan húmedas. Para aumentar la capacidad de deslizamiento de las barras de los jugadores, se recomienda usar sólo un spray de silicona de alta calidad. Si es posible, no se debe utilizar ninguna grasa vegetal o mineral.
- Si pasas el fútbolín a otra persona, asegúrate de que esta persona esté familiarizada con el contenido de las instrucciones de montaje y funcionamiento.
- Siempre coloque esta mesa de fútbolín en una superficie plana y sólida.
- Antes de cada uso debe comprobar el funcionamiento de todas las piezas y si no están en perfecto estado de funcionamiento, no utilice el fútbolín.
- Utilice siempre una capa inferior (cartón o alfombra) debajo de las patas de la mesa para proteger sus muebles.
- **ATENCIÓN:** Para evitar problemas al montar o fijar las patas de la mesa, primero atornille todas las patas de la mesa de la misma manera y luego atorníllelas bien.

ALCANCE DEL SUMINISTRO

<p>P1 = 2x</p>  <p>Parte lateral</p>	<p>P2 = 2x</p>  <p>Panel frontal</p>	<p>P3 = 1x</p>  <p>Campo de juego</p>	<p>P4A = 2x</p>  <p>Pata mesa a la izquierda</p>
<p>P4B = 2x</p>  <p>Pata mesa derecha</p>	<p>P5 = 2x</p>  <p>Cubierta pata de la mesa</p>	<p>P6 = 8x</p>  <p>Mango barra para jugar</p>	<p>P7 = 3x</p>  <p>Travesaño de deporte</p>
<p>P8A = 2x</p>  <p>Hueco para poner la pelota</p>	<p>P8B = 2x</p>  <p>Extremo de la parte P8A</p>	<p>P9 = 2x</p>  <p>Captador de pelota</p>	<p>P10 = 2x</p>  <p>Gol</p>
<p>P11 = 2x</p>  <p>Tubo para la pelota</p>	<p>P12 = 2x</p>  <p>Contador de puntos</p>	<p>H1 = 24x</p>  <p>Tornillo hexagonal</p>	<p>H2 = 24x</p>  <p>Arandela</p>
<p>H3 = 3x</p>  <p>Varilla roscada</p>	<p>H4 = 6x</p>  <p>Tuerca del sombrero</p>	<p>H5 = 6x</p>  <p>Arandela</p>	<p>H6 = 8x</p>  <p>Tornillo de cabeza hexagonal</p>
<p>H7 = 8x</p>  <p>Arandela</p>	<p>H8 = 8x</p>  <p>Tornillo de cabeza plana</p>	<p>H9 = 2x</p>  <p>Tornillo de cabeza redonda</p>	<p>H10 = 20x</p>  <p>Tornillo de cabeza redonda</p>

<p>H11 = 4x</p>  <p>Tornillo de cabeza plana</p>	<p>H12 = 4x</p>  <p>Pies de altura ajustable</p>	<p>C1 = 2x</p>  <p>Barra de 5 jugadores</p>	<p>C2 = 4x</p>  <p>Barra de 1+3 jugadores</p>
<p>C3 = 2x</p>  <p>Barra de 2 jugadores</p>	<p>C4 = 16x</p>  <p>Parachoques goma (barra juego)</p>	<p>C5 = 32x</p>  <p>Arandela de plástico</p>	<p>C6 = 26x</p>  <p>Tornillo para los jugadores</p>
<p>C7 = 26x</p>  <p>Tuerca para los jugadores</p>	<p>C8 = 11x / C9 = 11x</p>  <p>Figura de jugador</p>	<p>C10 = 4x</p>  <p>Tapón de portero</p>	<p>C11 = 16</p>  <p>Enchufe</p>
<p>P13 = 4x</p>  <p>Placa de montaje para los pies de altura ajustable</p>	<p>P14 = 4x</p>  <p>Las esquinas del campo de juego</p>	<p>P15 = 4x</p>  <p>Tapón</p>	<p>A1 = 2x</p>  <p>Pelota</p>
<p>A2 = 1x</p>  <p>Llave Allen pequeña</p>	<p>A3 = 2x</p>  <p>Llave Allen grande</p>	<p>P16 = 8x</p>  <p>Tapa del extremo</p>	

MONTAJE

Posicionando las barras

Cada equipo está formado por:

- el portero (poste con 1 jugador) al final del campo de juego posición A.
- los jugadores defensores (palo de 2 jugadores) directamente delante del portero de la misma posición de color B.
- los jugadores del centro del campo (barra con 5 jugadores) en el centro del campo de juego directamente opuesto a la barra con los 5 jugadores de la posición de color opuesto C.
- los delanteros (barra de 3 jugadores): en el centro del campo delante de la barra con los 2 jugadores del oponente de color posición D.

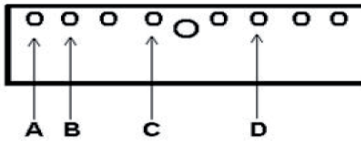

Mango lateral



Figura de jugador

Tapa

Contador de goles negro

Lado del equipo negro

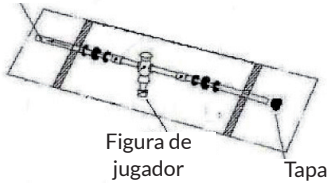
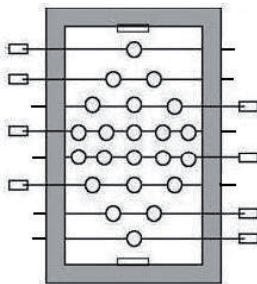

Lado del equipo blanco

Contador de goles blanco

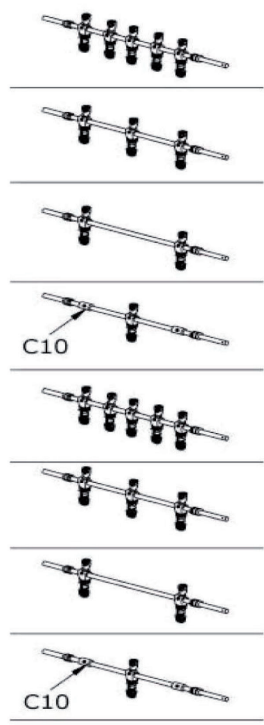
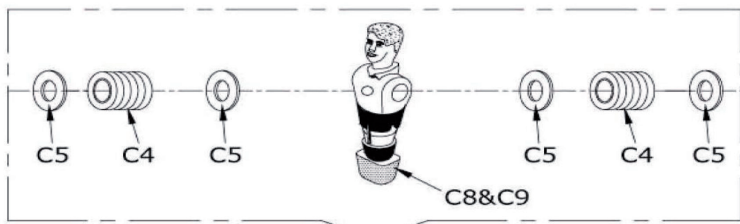

- R1 - Barra de 5 - Juego en casa 1x
- R2 - Barra de 3 - Juego en casa 1x
- R3 - Barra de 2 - Juego en casa 1x
- R4 - Barra de 1 - Juego en casa 1x
- R5 - Barra de 5 - Partido de ida 1x
- R6 - Barra de 3 - Partido de ida 1x
- R7 - Barra de 2 - Partido de ida 1x
- R8 - Barra de 1 - Partido de ida 1x

Paso 1

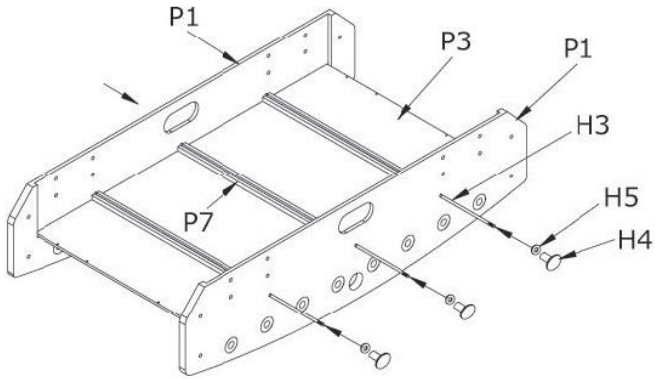

Paso 2

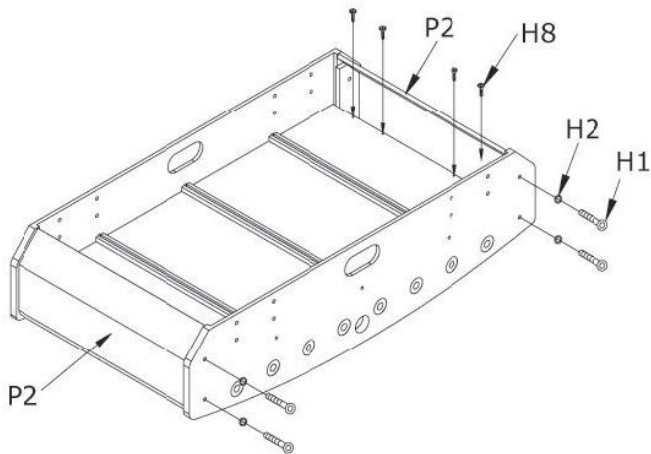

Paso 3

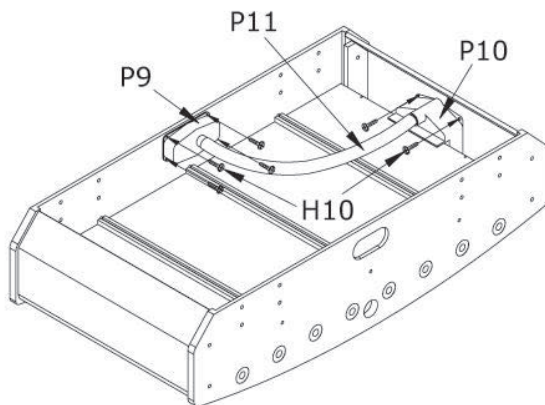

Paso 4

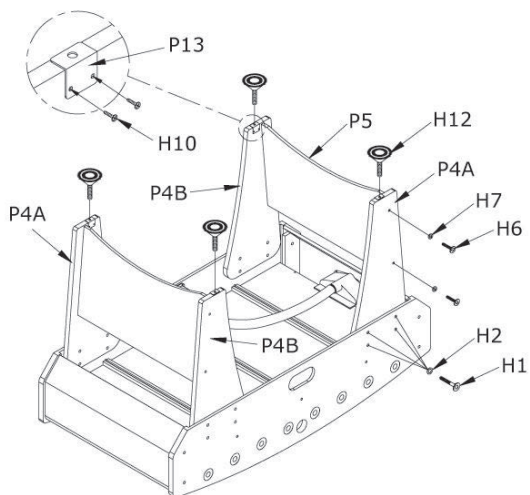

Paso 5

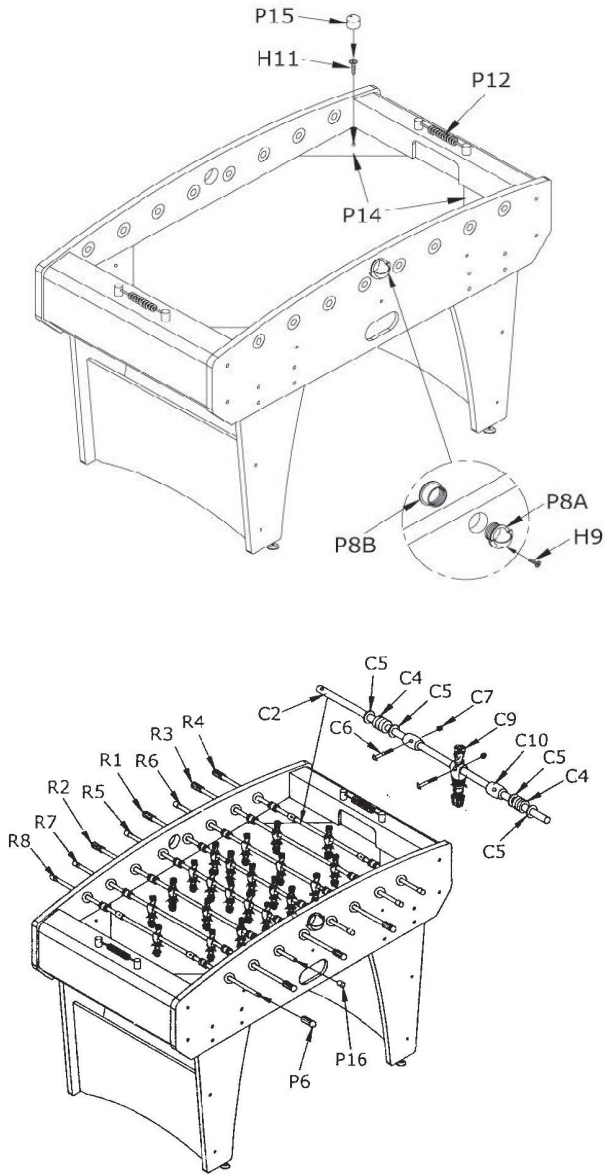

INDICACIONES SOBRE LA RETIRADA DEL FUTBOLÍN

Retirada

La eliminación del juego de futbolín no requiere ningún cuidado especial, ya que ningún componente está hecho de materiales peligrosos. Los siguientes materiales fueron usados para la construcción: Madera, MDF, acero, aluminio, ABS, PP, PE, PVC.

Estos materiales están contenidos particularmente en los siguientes componentes:

marcos: madera, MDF, acero.

las piernas: madera, acero.

superficie de juego: madera

Barras: Acero, PP (Moplen)

Accesorios: ABS, PE, PVC.

Equipo: aluminio, ABS.

Para su eliminación, recomendamos clasificar los componentes individuales según el tipo de material y entregarlos a puntos de recogida o reciclaje especialmente establecidos.

Gentile Cliente,

La ringraziamo per aver acquistato il dispositivo. La preghiamo di leggere attentamente le seguenti istruzioni per l'uso e di seguirle per evitare possibili danni tecnici. Non ci assumiamo alcuna responsabilità per danni scaturiti da una mancata osservazione delle avvertenze di sicurezza e da un uso improprio del dispositivo. Scansionare il codice QR seguente, per accedere al manuale d'uso più attuale e per ricevere informazioni sul prodotto.



INDICE

Artikel 3
 Konformitätserklärung 3
 Sicherheitshinweise 4
 Lieferumfang 5
 Montage 7
 Verwertung des Tischfußballspiels 12

ARTICOLO

Numero articolo	10033497, 10033498
-----------------	--------------------

DICHIARAZIONE DI CONFORMITÀ

Produttore:
 Chal-Tec GmbH, Wallstraße 16, 10179 Berlino,
 Germania.











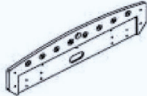
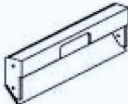

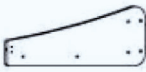









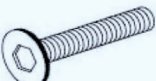



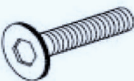

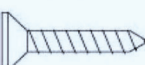
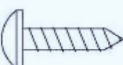
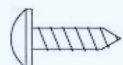

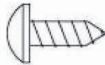





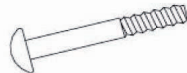

Questo prodotto è conforme alle seguenti direttive europee:
 2009/48/CE

AVVERTENZE DI SICUREZZA

- Il montaggio deve essere realizzato da un adulto. Il tavolo da calcetto assemblato è di dimensioni relativamente grandi e potrebbe non passare facilmente attraverso porte. Per questo motivo, consigliamo di assemblare il tavolo da calcetto nella stanza dove sarà poi posizionato.
- Se si desidera spostare il tavolo da calcetto in un'altra stanza, potrebbe essere necessario smontare le gambe e rimontarle una volta raggiunto il luogo desiderato per il posizionamento.
- Questo tavolo da calcetto è adatto solo per usi in contesti privati.
- Utilizzare il dispositivo solo per gli scopi previsti.
- Rispettare le avvertenze di sicurezza, in modo da garantire una lunga vita utile e una funzionalità ottimale del tavolo da calcetto.
- Non lasciare il tavolo da calcetto all'aperto. Pioggia, neve e umidità elevata danneggiano il materiale. Anche l'irraggiamento solare prolungato viene sconsigliato, dato che causa scolorimento.
- Pulire regolarmente il tavolo. Basta passare un panno umido sulle superfici per rimuovere polvere e altri residui. Per una pulizia più profonda, è possibile utilizzare un comune detergente, che non contenga cera o sostanze abrasive. Assicurarsi di rimuovere tutte le tracce di detergente e che le superfici non restino bagnate. Per aumentare la scorrevolezza delle aste, si consiglia di utilizzare solo spray al silicone di alta qualità. Evitare l'utilizzo di grassi vegetali o minerali.
- Se il tavolo da calcetto viene dato a un'altra persona, assicurarsi che questa conosca il contenuto del manuale d'uso e della guida al montaggio.
- Posizionare il campo da calcetto sempre su un fondo stabile e piano.
- Controllare la funzione di tutti i componenti prima di ogni uso e non utilizzarlo se non funziona in modo perfetto.
- Utilizzare sempre un appoggio (cartone o un tappeto) sotto alle gambe del tavolo, in modo da proteggere il pavimento.
- **ATTENZIONE:** per evitare problemi nel montaggio o fissaggio delle gambe del tavolo, avvitare prima tutte le gambe e procedere poi a stringerle saldamente.

VOLUME DI CONSEGNA

<p>P1 = 2x</p>  <p>Parte laterale</p>	<p>P2 = 2x</p>  <p>Pannello frontale</p>	<p>P3 = 1x</p>  <p>Campo di gioco</p>	<p>P4A = 2x</p>  <p>Gamba sinistra</p>
<p>P4B = 2x</p>  <p>Gamba destra</p>	<p>P5 = 2x</p>  <p>Copertura gamba del tavolo</p>	<p>P6 = 8x</p>  <p>Impugnature asta gioco</p>	<p>P7 = 3x</p>  <p>Barra obliqua di supporto</p>
<p>P8A = 2x</p>  <p>Apertura inserimento palla</p>	<p>P8B = 2x</p>  <p>Supporto inserimento palla</p>	<p>P9 = 2x</p>  <p>Contenitore raccolta palla</p>	<p>P10 = 2x</p>  <p>Porta</p>
<p>P11 = 2x</p>  <p>Condotto palla</p>	<p>P12 = 2x</p>  <p>Segnapunti</p>	<p>H1 = 24x</p>  <p>Vite a brugola 5/16"</p>	<p>H2 = 24x</p>  <p>Rondella 5/16"</p>
<p>H3 = 3x</p>  <p>Asta filettata</p>	<p>H4 = 6x</p>  <p>Dado a cappello</p>	<p>H5 = 6x</p>  <p>Rondella 3/8"</p>	<p>H6 = 8x</p>  <p>Vite a brugola 3/16"</p>
<p>H7 = 8x</p>  <p>Rondella 3/16"</p>	<p>H8 = 8x</p>  <p>Vite a testa piatta 1"</p>	<p>H9 = 2x</p>  <p>Vite a testa tonda 5/8"</p>	<p>H10 = 20x</p>  <p>Vite a testa tonda 1/4"</p>

<p>H11 = 4x</p>  <p>Vite a testa tonda 3/8"</p>	<p>H12 = 4x</p>  <p>Piedi regolabili in altezza</p>	<p>C1 = 2x</p>  <p>Asta per 5 giocatori</p>	<p>C2 = 4x</p>  <p>Asta per 1+3 giocatori</p>
<p>C3 = 2x</p>  <p>Asta per 2 giocatori</p>	<p>C4 = 16x</p>  <p>Cuscinetto gomma (asta per giocatori)</p>	<p>C5 = 32x</p>  <p>Rondella in plastica</p>	<p>C6 = 26x</p>  <p>Vite per giocatore</p>
<p>C7 = 26x</p>  <p>Dado per giocatore</p>	<p>C8 = 11x / C9 = 11x</p>  <p>Giocatore</p>	<p>C10 = 4x</p>  <p>Blocco porta</p>	<p>C11 = 16</p>  <p>Cuscinetto</p>
<p>P13 = 4x</p>  <p>Piastra di montaggio per piedi regolabili in altezza</p>	<p>P14 = 4x</p>  <p>Angoli per campo di gioco</p>	<p>P15 = 4x</p>  <p>Tappi</p>	<p>A1 = 2x</p>  <p>Palla</p>
<p>A2 = 1x</p>  <p>Chiave a brugola piccola</p>	<p>A3 = 2x</p>  <p>Chiave a brugola grande</p>	<p>P16 = 8x</p>  <p>Tappo di chiusura</p>	

MONTAGGIO

Posizionare le aste

Ogni squadra è composta da:

- Il portiere (asta con 1 giocatore) all'estremità del campo di gioco, posizione A.
- I difensori (asta con 2 giocatori) direttamente davanti al portiere dello stesso colore, posizione B.
- I centrocampisti (asta con 5 giocatori) al centro del campo di gioco, direttamente di fronte all'asta con 5 giocatori del colore avversario, posizione C.
- Gli attaccanti (asta con 3 giocatori) al centro del campo di gioco, davanti all'asta con 2 giocatori del colore avversario, posizione D.

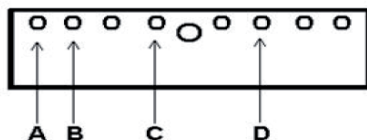

Foro lato
impugnatura

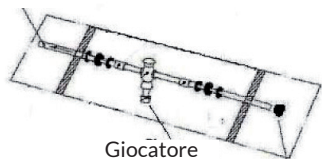

Giocatore

Tappo di
chiusura

Segnapunti
nero

Lato squadra nera

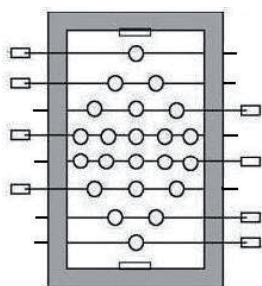

Lato squadra bianca

Segnapunti
bianco

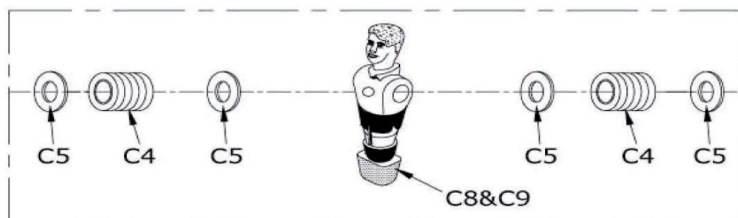

R1 - asta con 5 giocatori della squadra di casa **1x**



R2 - asta con 3 giocatori della squadra di casa **1x**



R3 - asta con 2 giocatori della squadra di casa **1x**



R4 - asta con 1 giocatore della squadra di casa **1x**



R5 - asta con 5 giocatori della squadra di trasferta **1x**

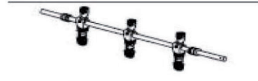

R6 - asta con 5 giocatori della squadra in trasferta **1x**



R7 - asta con 2 giocatori della squadra in trasferta **1x**



R8 - asta con 1 giocatori della squadra in trasferta **1x**

Passaggio 1

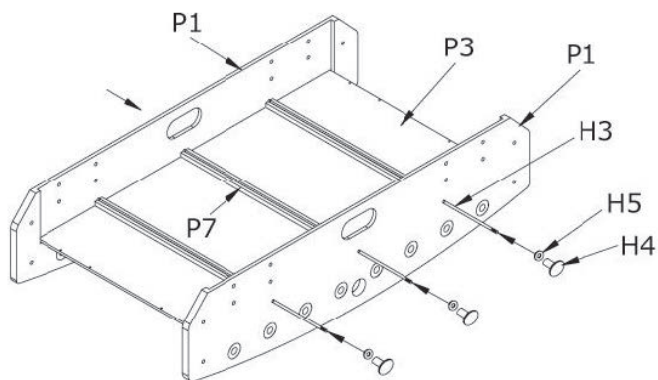

Passaggio 2

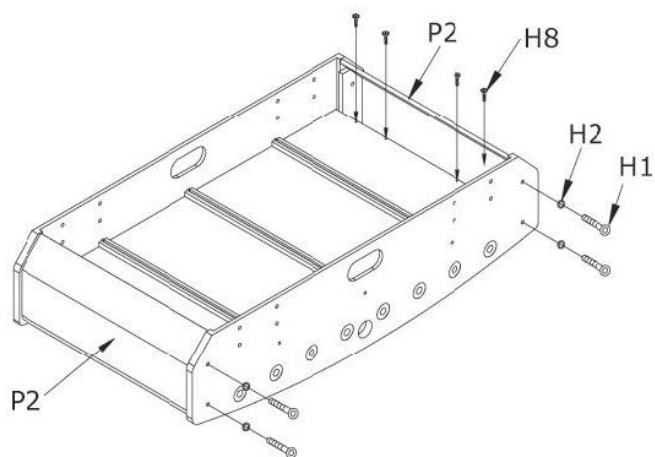

Passaggio 3

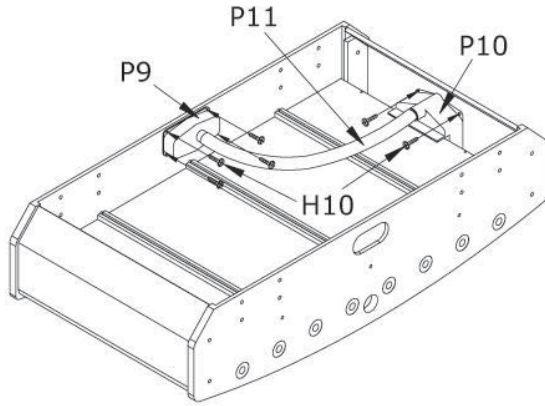

Passaggio 4

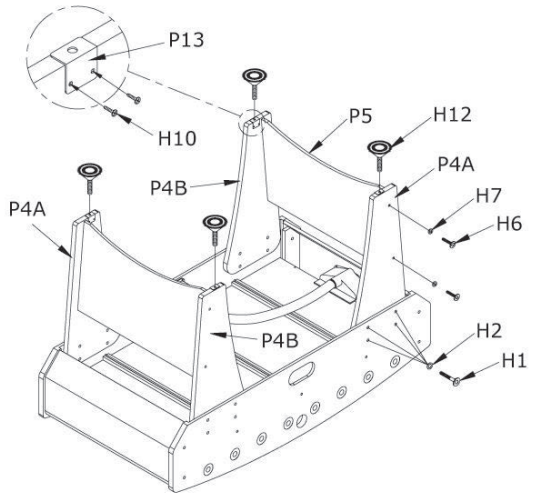

Passaggio 5

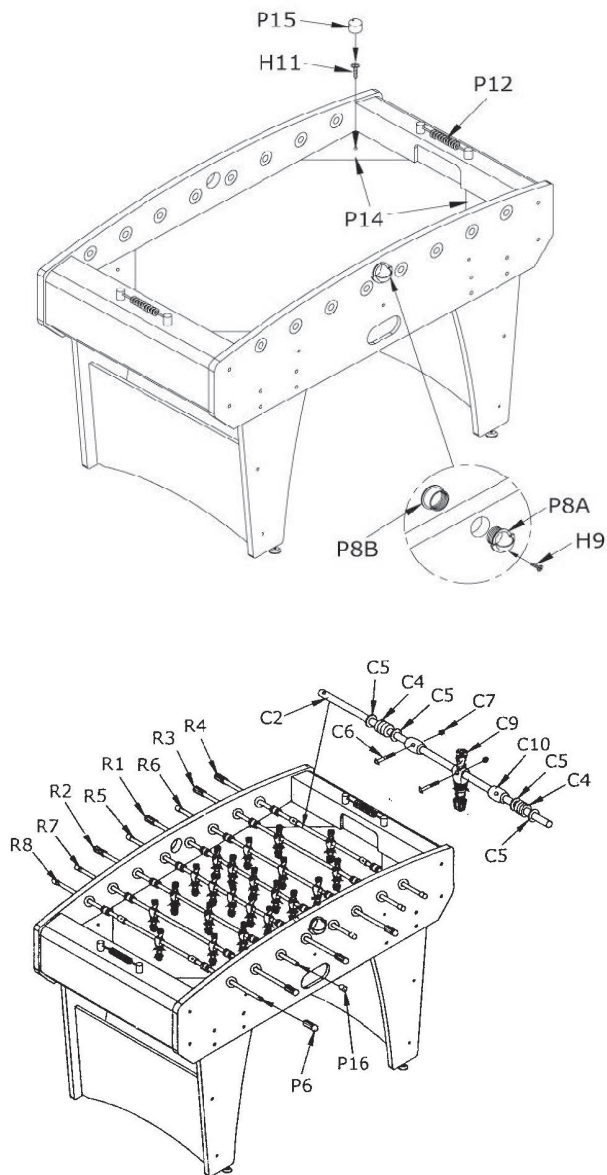

SMALTIMENTO DEL TAVOLO DA CALCETTO

Smaltimento

Lo smaltimento del tavolo da calcetto non richiede particolare attenzione, dato che nessuno dei componenti è composto da materiali pericolosi. Per la costruzione, sono stati utilizzati i seguenti materiali: legno, MDF, acciaio, alluminio, ABS, PP, PE, PVC.

Questi materiali sono contenuti in particolare nei seguenti componenti:

Telaio: legno, MDF, acciaio

Gambe: legno, acciaio

Superficie di gioco: legno

Aste: acciaio, PP (Moplen)

Accessori: ABS, PE, PVC

Equipaggiamento: alluminio, ABS

Per lo smaltimento si raccomanda di ordinare i singoli componenti in base al tipo di materiale e di consegnarli a punti di raccolta o di riciclaggio appositamente allestiti.

