

10033499 10033500

Spin

Spieltisch mit Kicker und Billard
Game Table with Soccer and Billard
Table de jeu avec football et billard
Mesa de juego con fútbol y billar
Tavolo da gioco con calcio e biliardo

Sehr geehrter Kunde,

wir gratulieren Ihnen zum Erwerb Ihres Gerätes. Lesen Sie die folgenden Hinweise sorgfältig durch und befolgen Sie diese, um möglichen Schäden vorzubeugen. Für Schäden, die durch Missachtung der Hinweise und unsachgemäßen Gebrauch entstehen, übernehmen wir keine Haftung. Scannen Sie den folgenden QR-Code, um Zugriff auf die aktuellste Bedienungsanleitung und weitere Informationen rund um das Produkt zu erhalten:

**Dear Customer,**

Congratulations on purchasing this device. Please read the following instructions carefully and follow them to prevent possible damages. We assume no liability for damage caused by disregard of the instructions and improper use. Scan the QR code to get access to the latest user manual and more product information.

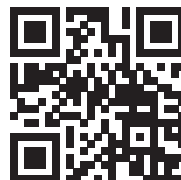
**Estimado cliente,**

Le felicitamos por la adquisición de este producto. Lea atentamente las siguientes instrucciones y sígalas para evitar posibles daños. No asumimos ninguna responsabilidad por los daños causados por el incumplimiento de las instrucciones y el uso inadecuado. Escanee el siguiente código QR para obtener acceso a la última guía del usuario y más información sobre el producto.

**Chère cliente, cher client,**

Toutes nos félicitations pour l'acquisition de ce nouvel appareil. Veuillez lire attentivement et respecter les instructions de ce mode d'emploi afin d'éviter d'éventuels dommages. Nous ne saurions être tenus pour responsables des dommages dus au non-respect des consignes et à la mauvaise utilisation de l'appareil. Scannez le QR-Code pour obtenir la dernière version du mode d'emploi et des informations supplémentaires concernant le produit.

**Gentile cliente,**







La ringraziamo per aver acquistato il dispositivo. La preghiamo di leggere attentamente le seguenti istruzioni per l'uso e di seguirle per evitare possibili danni. Non ci assumiamo alcuna responsabilità per danni scaturiti da una mancata osservazione delle avvertenze di sicurezza e da un uso improprio del dispositivo. Scansionare il codice QR seguente, per accedere al manuale d'uso più attuale e per ricevere informazioni sul prodotto.



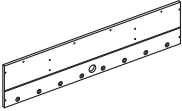
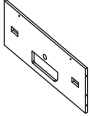
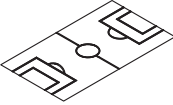
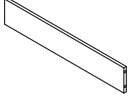
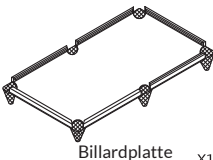
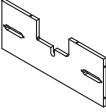

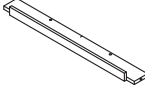
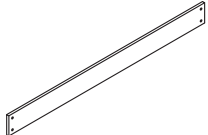
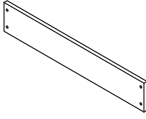
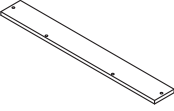



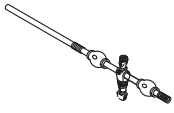
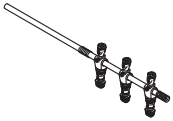
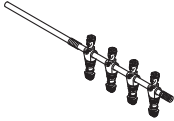
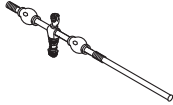
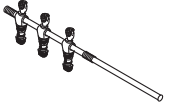



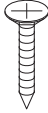

SICHERHEITSHINWEISE

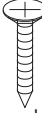
- Die Montage sollte durch einen Erwachsenen erfolgen. Der zusammengebaute Spieletisch ist in seinen Abmessungen relativ groß und könnte nicht gut durch Türen passen. Daher wird empfohlen, das Spieletisch in dem Raum zusammenzubauen, in dem gespielt werden soll.
- Falls Sie den Spieletisch in einen anderen Raum transportieren möchten, müssen möglicherweise die Beine erst abmontiert und dann wieder angebracht werden.
- Dieser Spieletisch ist nur für die private Nutzung geeignet.
- Verwenden Sie dieses Gerät ausschließlich für den beabsichtigten Zweck.
- Beachten Sie bitte die folgenden Sicherheitshinweise, um eine lange Lebensdauer und optimale Funktionstüchtigkeit Ihres Spieletischs zu gewährleisten:
 - Den Spieletisch nicht im Freien stehen lassen. Regen, Schnee und hohe Luftfeuchtigkeit schaden dem Material. Auch eine längere Sonneneinstrahlung ist aufgrund der ausbleichenden Wirkung auf die Farben nicht zu empfehlen.
 - Reinigen Sie den Tisch regelmäßig. Dabei genügt es, die Oberflächen mit einem feuchten Lappen abzuwischen, um Staub und andere Rückstände zu entfernen. Für eine gründlichere Reinigung kann man ein handelsübliches Reinigungsmittel verwenden, das weder Wachs noch ein Scheuermittel enthalten sollte. Bitte unbedingt darauf achten, dass alle Reinigungsmittelspuren restlos entfernt werden und die Oberflächen nicht nass bleiben. Um die Gleitfähigkeit der Spielerstangen zu erhöhen, wird empfohlen, ausschließlich ein hochwertiges Silikonspray zu verwenden. Es sollten möglichst keine Pflanzen- oder Mineralfette verwendet werden.
- Wenn Sie den Spieletisch an eine andere Person weitergeben stellen Sie sicher, dass diese Person den Inhalt der Aufbau- und Bedienungsanleitung kennt.
- Stellen Sie diesen Spieletisch immer auf einen ebenen und festen Untergrund.
- Vor jeder Nutzung sollten Sie alle Teile auf Ihre Funktion überprüfen und bei nicht einwandfreier Nutzbarkeit diesen Tisch nicht benutzen.
- Verwenden Sie immer eine Unterlage (Pappe oder Teppich) unter den Tischbeinen des Gerätes zum Schutz Ihrer Einrichtung.
- **ACHTUNG:** Um Probleme bei der Montage bzw. Befestigung der Tischbeine zu vermeiden, schrauben Sie zunächst alle Tischbeine gleich an und abschließend alle fest.

LIEFERUMFANG

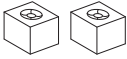
<p>P1</p>  <p>Seitenpanel x2</p>	<p>P2</p>  <p>Kopfpanel x2</p>	<p>P3</p>  <p>Spielfeld x1</p>	<p>P4</p>  <p>Halterung x2</p>
<p>P5</p>  <p>Billardplatte x1</p>	<p>P6</p>  <p>Beinstütze x2</p>	<p>P7</p>  <p>Beinwinkel rechts x2</p>	<p>P8</p>  <p>Beinwinkel links x2</p>
<p>P9</p>  <p>Spielbrettblende x2</p>	<p>P10</p>  <p>Beinseitenverkleidung x2</p>	<p>P11</p>  <p>Beinabschlussblende x2</p>	<p>P12</p>  <p>obere Endplatte x2</p>
<p>F1</p>  <p>Kunststoffstreifen x4</p>	<p>F2</p>  <p>Ecktasche x4</p>	<p>F3</p>  <p>Seitentasche x2</p>	<p>F4</p>  <p>1er-Spielfigurstange (rot)x1</p>
<p>F5</p>  <p>2er-Spielfigurstange (rot) x2</p>	<p>F6</p>  <p>4er-Spielfigurstange (rot) x1</p>	<p>F7</p>  <p>1er-Spielfigurstange (blau) x1</p>	<p>F8</p>  <p>2er-Spielfigurstange (blau) x2</p>







<p>F9</p> <p>X1</p>	<p>F10</p> <p>X8</p>	<p>F11</p> <p>X8</p>	<p>F12</p> <p>X8</p>
<p>F13</p> <p>X2</p>	<p>F14</p> <p>X8</p>	<p>F15</p> <p>X8</p>	<p>F16</p> <p>X4</p>
<p>Rotationsachse</p>	<p>Handgriff</p>	<p>Stopper</p>	<p>Sicherungsstift</p>
<p>F17</p> <p>X4</p>	<p>F18</p> <p>X2</p>	<p>F19</p> <p>X2</p>	<p>F20</p> <p>X2</p>
<p>Fußverstellungsschraube</p>	<p>Tor</p>	<p>Auffangkorb</p>	<p>Punkttestand</p>
<p>H1</p> <p>X16</p>	<p>H2</p> <p>X8</p>	<p>H3</p> <p>X12</p>	<p>H4</p> <p>X18</p>
<p>Schraube 3,5x1-3/4"</p>	<p>Schraube 3x1/2"</p>	<p>Schraube T3,5x21mm</p>	<p>Schraube T3,5x1/2" mm</p>
<p>H5</p> <p>X8</p>	<p>H6</p> <p>X8</p>	<p>H7</p> <p>X8</p>	<p>H8</p> <p>X8</p>
<p>Schraube 3,5x1-3/4"</p>	<p>Schraube 1/4"</p>	<p>Mutter 1/4"</p>	<p>Schraube T5/32 X1</p>



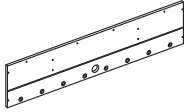
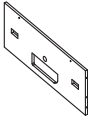
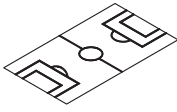
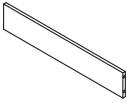
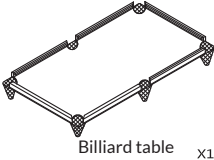
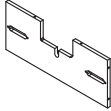

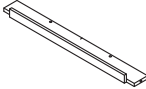
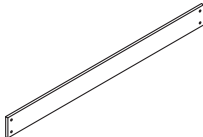
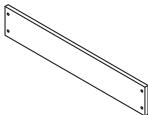
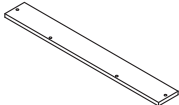



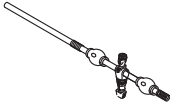
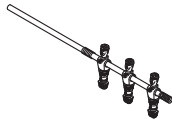
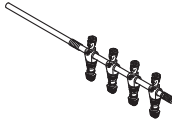
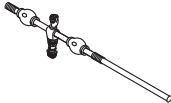
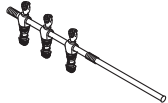

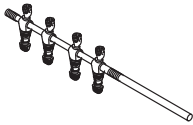



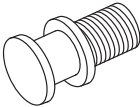
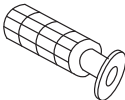

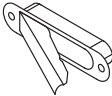

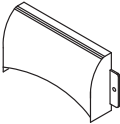
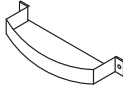
<p>H9</p>  <p>x8</p>	<p>H10</p>  <p>x32</p>	<p>H11</p>  <p>x8</p>	<p>H12</p>  <p>x16</p>
Mutter 4/32"	Unterlegscheibe 1/4"x16 mm	Schraube 1/4"x1-1/2"	Schraube F4x1-1/2"
<p>H13</p>  <p>x16</p>	<p>H14</p>  <p>x4</p>	<p>A1</p>  <p>x1</p>	<p>A2</p>  <p>x1</p>
Innensechskant 4/32"	Schraube 3,5x1	Satz Billardkugeln	Triangel
<p>A3</p>  <p>x2</p>	<p>A4</p>  <p>x2</p>	<p>A5</p>  <p>x1</p>	<p>A6</p>  <p>x2</p>
Queue	Kreide	Bürste	Spielfußball
<p>T1</p>  <p>x1</p>	<p>T2</p>  <p>x1</p>		
Innensechskant-Schlüssel	Schrauben-Schlüssel		





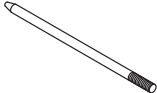





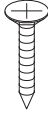

SAFETY INSTRUCTIONS

- Assembly should be carried out by an adult. The assembled game table is relatively large in its dimensions and might not fit well through doors. Therefore, it is recommended to assemble the game table in the room where the game is to be played.
- If you want to transport the game table to another room, the legs may first have to be dismantled and then reattached.
- This game table is only suitable for private use.
- Use this device only for its intended purpose.
- Please observe the following safety instructions to ensure a long service life and optimum functionality of your game table:
- Do not leave the game table outdoors. Rain, snow and high humidity damage the material. Prolonged exposure to sunlight is also not recommended due to the fading effect on the colours.
- Clean the table regularly. It is sufficient to wipe the surfaces with a damp cloth to remove dust and other residues. For a more thorough cleaning, you can use a commercial cleaning agent that should not contain wax or an abrasive. Please make absolutely sure that all traces of cleaning agent are completely removed and that the surfaces do not remain wet. To increase the sliding ability of the player rods, it is recommended to use only a high-quality silicone spray. If possible, no vegetable or mineral fats should be used.
- If you pass the game table on to another person, make sure that this person knows the contents of the assembly and operating instructions.
- Always place this game table on a level and firm surface.
- Before each use, check all parts for proper function and do not use this table if it is not in perfect working order.
- Always use an underlay (cardboard or carpet) under the table legs of the appliance to protect your furnishings.
- **ATTENTION:** To avoid problems when assembling or fixing the table legs, first screw all table legs on at the same time and only screw them all tight at the end.

SCOPE OF DELIVERY

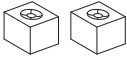
<p>P1</p>  <p>Side panel x2</p>	<p>P2</p>  <p>Head panel x2</p>	<p>P3</p>  <p>Playing field x1</p>	<p>P4</p>  <p>Holder x2</p>
<p>P5</p>  <p>Billiard table x1</p>	<p>P6</p>  <p>Leg support x2</p>	<p>P7</p>  <p>Leg angle right x2</p>	<p>P8</p>  <p>Leg angle left x2</p>
<p>P9</p>  <p>Board cover x2</p>	<p>P10</p>  <p>Leg side panel x2</p>	<p>P11</p>  <p>Leg trim x2</p>	<p>P12</p>  <p>Upper end plate x2</p>
<p>F1</p>  <p>Plastic strips x4</p>	<p>F2</p>  <p>Corner pocket x4</p>	<p>F3</p>  <p>Side pocket x2</p>	<p>F4</p>  <p>1-pc play figure bar (red)x1</p>
<p>F5</p>  <p>2-pc play figure bar (red) x2</p>	<p>F6</p>  <p>4-pc play figure bar (red) x1</p>	<p>F7</p>  <p>1-pc play figure bar (blue) x1</p>	<p>F8</p>  <p>2-pc play figure bar (blue) x2</p>









<p>F9</p>  <p>x1</p>	<p>F10</p>  <p>x8</p>	<p>F11</p>  <p>x8</p>	<p>F12</p>  <p>x8</p>
<p>4-pc play figure bar (blue)</p>	<p>Plastic washer</p>	<p>Washer 1/4" x 25 mm</p>	<p>Washer 1/4" x 25 mm</p>
<p>F13</p>  <p>x2</p>	<p>F14</p>  <p>x8</p>	<p>F15</p>  <p>x8</p>	<p>F16</p>  <p>x4</p>
<p>Rotation axis</p>	<p>Handle</p>	<p>Stopper</p>	<p>Locking pin</p>
<p>F17</p>  <p>x4</p>	<p>F18</p>  <p>x2</p>	<p>F19</p>  <p>x2</p>	<p>F20</p>  <p>x2</p>
<p>Foot adjustment screw</p>	<p>Goal</p>	<p>Collecting basket</p>	<p>Scorekeeper</p>
<p>H1</p>  <p>x16</p>	<p>H2</p>  <p>x8</p>	<p>H3</p>  <p>x12</p>	<p>H4</p>  <p>x18</p>
<p>Screw 3.5x1-3/4"</p>	<p>Screw 3x1/2"</p>	<p>Screw T3.5x21mm</p>	<p>Screw T3.5x1/2" mm</p>
<p>H5</p>  <p>x8</p>	<p>H6</p>  <p>x8</p>	<p>H7</p>  <p>x8</p>	<p>H8</p>  <p>x8</p>
<p>Screw 3.5x1-3/4"</p>	<p>Screw 1/4"</p>	<p>Nut 1/4"</p>	<p>Screw T5/32 X1</p>

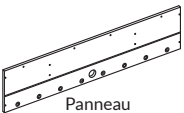
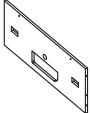
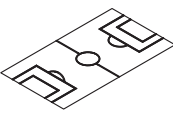
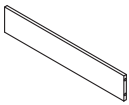
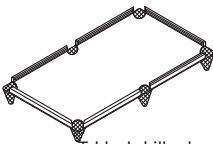
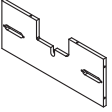

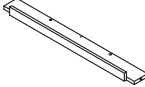
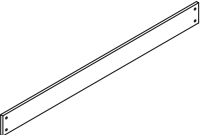
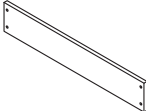
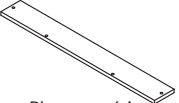



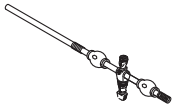

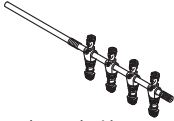
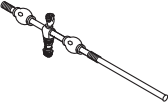
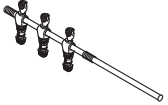

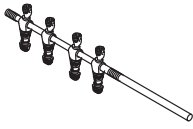



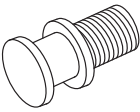
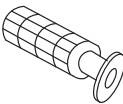

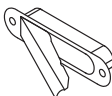
<p>H9</p>  <p>Nut 4/32" x8</p>	<p>H10</p>  <p>Washer 1/4"x16 mm x32</p>	<p>H11</p>  <p>Screw 1/4"x1-1/2" x8</p>	<p>H12</p>  <p>Screw F4x1-1/2" x16</p>
<p>H13</p>  <p>Hexagon socket 4/32" x16</p>	<p>H14</p>  <p>Screw 3.5x1 x4</p>	<p>A1</p>  <p>Set Billiard balls x1</p>	<p>A2</p>  <p>Triangle x1</p>
<p>A3</p>  <p>Cue x2</p>	<p>A4</p>  <p>Chalk x2</p>	<p>A5</p>  <p>Brush x1</p>	<p>A6</p>  <p>Football x2</p>
<p>T1</p>  <p>Hexagon socket-wrench x1</p>	<p>T2</p>  <p>Screw wrench x1</p>		

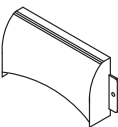
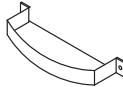
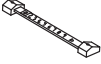
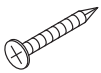



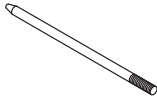

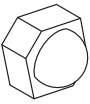



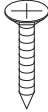

CONSIGNES DE SÉCURITÉ

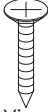
- Le montage doit être effectué par un adulte. La table de jeu assemblée est de dimensions relativement grandes et peut ne pas bien passer les portes. Il est donc recommandé d'assembler la table de jeu dans la pièce où l'on veut jouer.
- Si vous souhaitez transporter la table de jeu dans une autre pièce, il est possible que vous deviez d'abord démonter les pieds, puis les remonter.
- Cette table de jeu est uniquement destinée à un usage privé.
- N'utilisez cet appareil que pour l'usage auquel il est destiné.
- Veuillez respecter les consignes de sécurité suivantes afin de garantir une longue durée de vie et un fonctionnement optimal de votre table de jeu :
- Ne pas laisser la table de jeu à l'extérieur. La pluie, la neige et une forte humidité de l'air endommageraient le matériau. Une exposition prolongée au soleil n'est pas non plus recommandée en raison de son effet décolorant sur les couleurs.
- Nettoyez régulièrement la table. Il suffit pour cela d'essuyer les surfaces avec un chiffon humide pour enlever la poussière et les autres résidus. Pour un nettoyage plus approfondi, vous pouvez utiliser un produit de nettoyage courant sans cire ni produit abrasif. Veuillez impérativement à ce que toutes les traces de produits de nettoyage soient entièrement éliminées et à ce que les surfaces ne restent pas humides. Pour augmenter la capacité de glissement des barres des joueurs, il est recommandé d'utiliser exclusivement un spray au silicone de haute qualité. Dans la mesure du possible, il convient d'éviter d'utiliser des graisses végétales ou minérales.
- Si vous remettez la table de jeu à une autre personne, assurez-vous qu'elle prenne connaissance des instructions de montage et d'utilisation.
- Placez toujours cette table de jeu sur une surface plane et solide.
- Avant chaque utilisation, il convient de vérifier le bon fonctionnement de toutes les pièces et de ne pas utiliser cette table si elle n'est pas parfaitement utilisable.
- Utilisez toujours un support (carton ou tapis) sous les pieds de table de l'appareil pour protéger votre sol.
- ATTENTION : Pour éviter tout problème lors du montage ou de la fixation des pieds de table, commencez par visser tous les pieds de table de la même manière et terminez en les serrant tous.

CONTENU DE L'EMBALLAGE

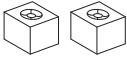
<p>P1</p>  <p>Panneau latéral X2</p>	<p>P2</p>  <p>Panneau de tête X2</p>	<p>P3</p>  <p>Terrain de jeu X1</p>	<p>P4</p>  <p>Support X2</p>
<p>P5</p>  <p>Table de billard X1</p>	<p>P6</p>  <p>Repose-jambes X2</p>	<p>P7</p>  <p>Équerre de pied droit X2</p>	<p>P8</p>  <p>Équerre de pied gauche X2</p>
<p>P9</p>  <p>Cache du plateau de jeu X2</p>	<p>P10</p>  <p>Revêtement latéral des pieds X2</p>	<p>P11</p>  <p>Bandeau de bas de pied X2</p>	<p>P12</p>  <p>Plaque supérieure d'extrémité X2</p>
<p>F1</p>  <p>Bande plastique X4</p>	<p>F2</p>  <p>Poche d'angle X4</p>	<p>F3</p>  <p>Poche latérale X2</p>	<p>F4</p>  <p>barre de 1 joueur (rouge) X1</p>
<p>F5</p>  <p>barre de 2 joueurs (rouge) X2</p>	<p>F6</p>  <p>barre de 4 joueurs (rouge) X1</p>	<p>F7</p>  <p>barre de 1 joueur (bleu) X1</p>	<p>F8</p>  <p>barre de 2 joueurs (bleu) X2</p>







<p>F9</p>  <p style="text-align: right;">x1</p>	<p>F10</p>  <p style="text-align: right;">x8</p>	<p>F11</p>  <p style="text-align: right;">x8</p>	<p>F12</p>  <p style="text-align: right;">x8</p>
<p>barre de 4 joueurs (bleu)</p>	<p>Rondelle en plastique</p>	<p>Rondelle 1/4" x 25 mm</p>	<p>Rondelle 1/4" x 25 mm</p>
<p>F13</p>  <p style="text-align: right;">x2</p>	<p>F14</p>  <p style="text-align: right;">x8</p>	<p>F15</p>  <p style="text-align: right;">x8</p>	<p>F16</p>  <p style="text-align: right;">x4</p>
<p>Axe de rotation</p>	<p>Poignée</p>	<p>Butée</p>	<p>Goupille de sécurité</p>
<p>F17</p>  <p style="text-align: right;">x4</p>	<p>F18</p>  <p style="text-align: right;">x2</p>	<p>F19</p>  <p style="text-align: right;">x2</p>	<p>F20</p>  <p style="text-align: right;">x2</p>
<p>Vis de réglage du pied</p>	<p>But</p>	<p>Panier collecteur</p>	<p>Score</p>
<p>H1</p>  <p style="text-align: right;">x16</p>	<p>H2</p>  <p style="text-align: right;">x8</p>	<p>H3</p>  <p style="text-align: right;">x12</p>	<p>H4</p>  <p style="text-align: right;">x18</p>
<p>Vis 3,5x1-3/4"</p>	<p>Vis 3x1/2"</p>	<p>Vis T3,5x21 mm</p>	<p>Vis T3,5x1/2" mm</p>
<p>H5</p>  <p style="text-align: right;">x8</p>	<p>H6</p>  <p style="text-align: right;">x8</p>	<p>H7</p>  <p style="text-align: right;">x8</p>	<p>H8</p>  <p style="text-align: right;">x8</p>
<p>Vis 3,5x1-3/4"</p>	<p>Vis 1/4"</p>	<p>Écrou 1/4"</p>	<p>Vis T5/32 X1</p>



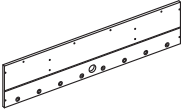
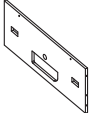
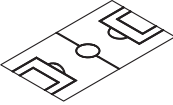
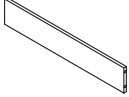
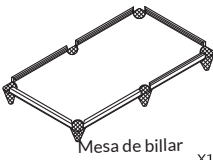
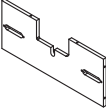

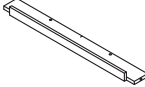
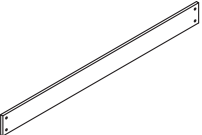
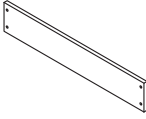
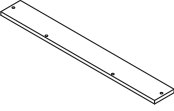



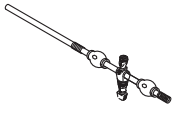
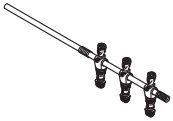
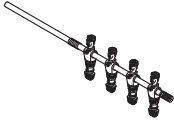
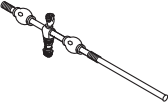
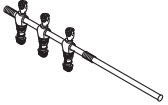

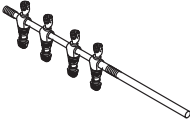



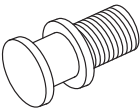
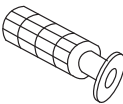

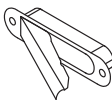
<p>H9</p>  <p>x8</p> <p>Écrou 4/32"</p>	<p>H10</p>  <p>x32</p> <p>Rondelle 1/4"x16 mm</p>	<p>H11</p>  <p>x8</p> <p>Vis 1/4"x1-1/2"</p>	<p>H12</p>  <p>x16</p> <p>Vis F4x1-1/2"</p>
<p>H13</p>  <p>x16</p> <p>Allen 4/32"</p>	<p>H14</p>  <p>x4</p> <p>Vis 3,5x1</p>	<p>A1</p>  <p>x1</p> <p>Jeu de boules de billard</p>	<p>A2</p>  <p>x1</p> <p>Triangle</p>
<p>A3</p>  <p>x2</p> <p>Queue</p>	<p>A4</p>  <p>x2</p> <p>Craie</p>	<p>A5</p>  <p>x1</p> <p>Brosse</p>	<p>A6</p>  <p>x2</p> <p>Jeu de football</p>
<p>T1</p>  <p>x1</p> <p>Clé Allen</p>	<p>T2</p>  <p>x1</p> <p>Clé</p>		

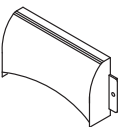
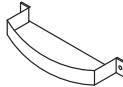
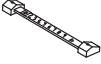
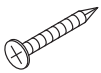



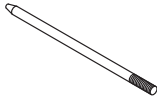

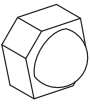

INDICACIONES DE SEGURIDAD

- Solamente los adultos deben montar el futbolín. El artículo montado es relativamente grande en tamaño y podría no pasar por la puerta. Por ello, se recomienda montar el futbolín directamente en la sala en la que se jugará.
- Si desea mover el futbolín a otra habitación, es posible que primero deba desmontar las patas y luego volver a montarlas.
- El futbolín solo es apto para uso privado.
- Utilice este artículo solamente con el fin para el cual ha sido concebido.
- Siga las siguientes indicaciones de seguridad para garantizar una larga vida útil y una óptima funcionalidad del futbolín:
- No utilice el futbolín al aire libre. La lluvia, nieve y alta humedad dañan el material. Tampoco se recomienda una exposición prolongada a la luz solar, ya que los colores pierden su intensidad.
- Limpie el futbolín regularmente. Limpie las superficies con un paño húmedo para eliminar el polvo y otros residuos. Para una limpieza más profunda, use un producto de limpieza convencional que no contenga cera y que no sea abrasivo. Asegúrese de eliminar por completo los restos del producto de limpieza y de que las superficies no permanecen húmedas. Para aumentar la capacidad de deslizamiento de las varillas, utilice únicamente un spray de sílica de alta calidad. En la medida de lo posible, no aplique grasas vegetales o minerales.
- Si entrega el futbolín a otra persona, asegúrese de que esté familiarizada con el contenido de las instrucciones de montaje y funcionamiento.
- Coloque el futbolín sobre una superficie nivelada y firme.
- Antes de cada uso, compruebe el funcionamiento de todas las piezas y no utilice el futbolín si no está en perfecto estado de funcionamiento.
- Utilice siempre una base (de cartón o alfombra) debajo de las patas del artículo para proteger los muebles.
- **ATENCIÓN:** Para evitar problemas al montar o fijar las patas de la mesa, primero atornille todas las patas de la mesa y luego apriételas.

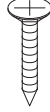
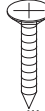
PARTES SUMINISTRADAS

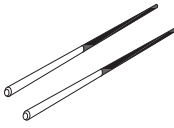
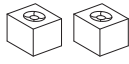
<p>P1</p>  <p>Panel lateral X2</p>	<p>P2</p>  <p>Panel frontal X2</p>	<p>P3</p>  <p>Campo de juego X1</p>	<p>P4</p>  <p>Soporte X2</p>
<p>P5</p>  <p>Mesa de billar X1</p>	<p>P6</p>  <p>Soporte de la pata X2</p>	<p>P7</p>  <p>Pata derecha X2</p>	<p>P8</p>  <p>Pata izquierda X2</p>
<p>P9</p>  <p>Panel del campo X2</p>	<p>P10</p>  <p>Placa lateral de la pata X2</p>	<p>P11</p>  <p>Tapa de la pierna X2</p>	<p>P12</p>  <p>Placa superior X2</p>
<p>F1</p>  <p>Tiras de plástico X4</p>	<p>F2</p>  <p>Tronera esquinera X4</p>	<p>F3</p>  <p>Tronera lateral X2</p>	<p>F4</p>  <p>Primera varilla (roja) X1</p>
<p>F5</p>  <p>Segunda varilla (roja) X2</p>	<p>F6</p>  <p>Cuarta varilla (roja) X1</p>	<p>F7</p>  <p>Primera varilla (azul) X1</p>	<p>F8</p>  <p>Segunda varilla (azul) X2</p>







<p>F9</p>  <p style="text-align: right;">x1</p>	<p>F10</p>  <p style="text-align: right;">x8</p>	<p>F11</p>  <p style="text-align: right;">x8</p>	<p>F12</p>  <p style="text-align: right;">x8</p>
<p>Cuarta varilla (azul)</p>		<p>Arandela 1/4" x 25 mm</p>	
<p>F13</p>  <p style="text-align: right;">x2</p>	<p>F14</p>  <p style="text-align: right;">x8</p>	<p>F15</p>  <p style="text-align: right;">x8</p>	<p>F16</p>  <p style="text-align: right;">x4</p>
<p>Eje de rotación</p>		<p>Agarre</p>	
<p>F17</p>  <p style="text-align: right;">x4</p>	<p>F18</p>  <p style="text-align: right;">x2</p>	<p>F19</p>  <p style="text-align: right;">x2</p>	<p>F20</p>  <p style="text-align: right;">x2</p>
<p>Tornillo de pata</p>		<p>Portería</p>	
<p>H1</p>  <p style="text-align: right;">x16</p>	<p>H2</p>  <p style="text-align: right;">x8</p>	<p>H3</p>  <p style="text-align: right;">x12</p>	<p>H4</p>  <p style="text-align: right;">x18</p>
<p>Tornillo 3,5x1-3/4"</p>		<p>Tornillo 3x1/2"</p>	
<p>H5</p>  <p style="text-align: right;">x8</p>	<p>H6</p>  <p style="text-align: right;">x8</p>	<p>H7</p>  <p style="text-align: right;">x8</p>	<p>H8</p>  <p style="text-align: right;">x8</p>
<p>Tornillo 3,5x1-3/4"</p>		<p>Tornillo 1/4"</p>	
<p>Tornillo 3,5x1-3/4"</p>		<p>Tuerca 1/4"</p>	
<p>Tornillo 3,5x1-3/4"</p>		<p>Tornillo T5/32 X1</p>	



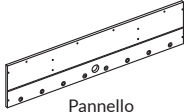
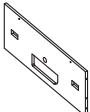
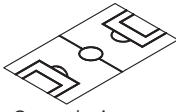
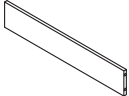
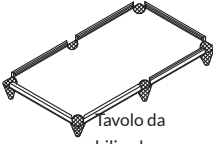
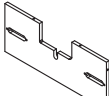

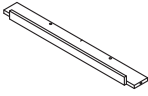
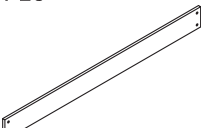
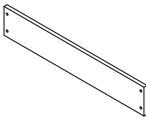
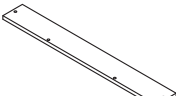



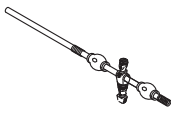
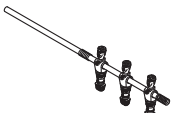
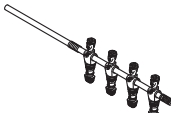
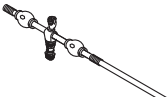
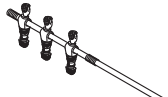

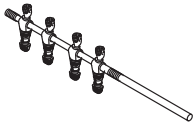



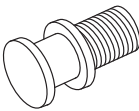
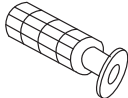

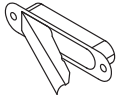
<p>H9</p>  <p>x8</p> <p>Tuerca 4/32"</p>	<p>H10</p>  <p>x32</p> <p>Arandela 1/4"x16 mm</p>	<p>H11</p>  <p>x8</p> <p>Tornillo 1/4"x1-1/2"</p>	<p>H12</p>  <p>x16</p> <p>Tornillo F-4x1-1/2"</p>
<p>H13</p>  <p>x16</p> <p>Tornillo hexagonal de 4/32"</p>	<p>H14</p>  <p>x4</p> <p>Tornillo 3,5x1</p>	<p>A1</p>  <p>x1</p> <p>Juego de bolas de billar</p>	<p>A2</p>  <p>x1</p> <p>Triángulo</p>
<p>A3</p>  <p>x2</p> <p>Taco</p>	<p>A4</p>  <p>x2</p> <p>Tiza</p>	<p>A5</p>  <p>x1</p> <p>Cepillo</p>	<p>A6</p>  <p>x2</p> <p>Bola de fútbol</p>
<p>T1</p>  <p>x1</p> <p>Llave hexagonal</p>	<p>T2</p>  <p>x1</p> <p>Llave inglesa</p>		

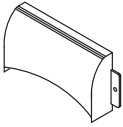
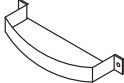
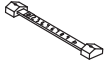
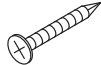



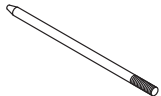





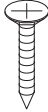

AVVERTENZE DI SICUREZZA

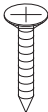
- Il montaggio deve essere effettuato da un adulto. Il tavolo da gioco assemblato è relativamente grande e potrebbe dare problemi a passare per le porte. Pertanto, si raccomanda di montare il tavolo da gioco nella stanza in cui si giocherà.
- Se si vuole trasportare il tavolo da gioco in un'altra stanza, è possibile che le gambe debbano prima essere smontate e poi riattaccate.
- Questo tavolo da gioco è adatto solo per uso privato.
- Usare questo dispositivo solo per lo scopo previsto.
- Si prega di osservare le seguenti istruzioni di sicurezza per garantire una lunga durata e una funzionalità ottimale del tavolo da gioco:
- Non lasciare il tavolo da gioco all'aperto. La pioggia, la neve e l'alta umidità danneggiano il materiale. Si sconsiglia anche l'esposizione prolungata al sole, dato che i colori potrebbero sbiadirsi.
- Pulire regolarmente il tavolo. È sufficiente pulire le superfici con un panno umido per rimuovere la polvere e altri residui. Per una pulizia più approfondita, si può usare un detergente reperibile in commercio che non deve contenere cera o sostanze abrasive. Assicurarsi assolutamente che tutte le tracce di detergente siano completamente rimosse e che le superfici non rimangano bagnate. Per aumentare la capacità di scorrimento delle aste del calcio balilla, si raccomanda di utilizzare solo uno spray al silicone di alta qualità. Se possibile, non si devono usare grassi vegetali o minerali.
- Se si passa il tavolo da gioco a un'altra persona, assicurarsi che questa persona conosca il contenuto delle istruzioni di montaggio e d'uso.
- Posizionare sempre il tavolo da gioco su una superficie piana e solida.
- Prima di ogni utilizzo, controllare che tutte le parti funzionino correttamente e non usare questo tavolo se non è in perfetto stato di funzionamento.
- Usare sempre un supporto (cartone o tappeto) sotto le gambe del tavolo del dispositivo per proteggere i propri mobili.
- **ATTENZIONE:** per evitare problemi durante il montaggio o il fissaggio delle gambe del tavolo, avvitare prima tutte le gambe allo stesso modo e infine stringerle.

VOLUME DI CONSEGNA

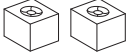
<p>P1</p>  <p>Pannello laterale X2</p>	<p>P2</p>  <p>Pannello anteriore X2</p>	<p>P3</p>  <p>Campo da gioco X1</p>	<p>P4</p>  <p>Supporto X2</p>
<p>P5</p>  <p>Tavolo da biliardo X1</p>	<p>P6</p>  <p>Poggia gambe X2</p>	<p>P7</p>  <p>Angolo gamba destra X2</p>	<p>P8</p>  <p>Angolo gamba sinistra X2</p>
<p>P9</p>  <p>Copertura del tavolo da gioco X2</p>	<p>P10</p>  <p>Copertura laterale della gamba X2</p>	<p>P11</p>  <p>Copertura finale gamba X2</p>	<p>P12</p>  <p>Pannello finale superiore X2</p>
<p>F1</p>  <p>Strisce di plastica X4</p>	<p>F2</p>  <p>Buca d'angolo X4</p>	<p>F3</p>  <p>Tasca laterale X2</p>	<p>F4</p>  <p>asta con 1 calciatore (rossa) X1</p>
<p>F5</p>  <p>asta con 2 calciatori (rossa) X2</p>	<p>F6</p>  <p>asta con 4 calciatori (rossa) X1</p>	<p>F7</p>  <p>asta con 1 calciatore (blu) X1</p>	<p>F8</p>  <p>asta con 2 calciatori (blu) X2</p>

<p>F9</p>  <p>x1</p>	<p>F10</p>  <p>Rondella di plastica X8</p>	<p>F11</p>  <p>Rondella X8</p> <p>1/4" x 25 mm</p>	<p>F12</p>  <p>Rondella X8</p> <p>1/4" x 25 mm</p>
<p>F13</p>  <p>x2</p>	<p>F14</p>  <p>x8</p>	<p>F15</p>  <p>x8</p>	<p>F16</p>  <p>x4</p>
Asse di rotazione	Impugnatura	Tappo	Perno di fissaggio
<p>F17</p>  <p>Vite di regolazione deK4 piede</p>	<p>F18</p>  <p>x2</p>	<p>F19</p>  <p>x2</p>	<p>F20</p>  <p>x2</p>
	Porta	Raccogli palla	Segnapunti
<p>H1</p>  <p>x16</p>	<p>H2</p>  <p>x8</p>	<p>H3</p>  <p>x12</p>	<p>H4</p>  <p>x18</p>
Vite 3,5x1-3/4"	Vite 3x1/2"	Vite T3,5x21mm	Vite T3,5x1/2"mm
<p>H5</p>  <p>x8</p>	<p>H6</p>  <p>x8</p>	<p>H7</p>  <p>x8</p>	<p>H8</p>  <p>x8</p>
Vite 3,5x1-3/4"	Vite 1/4"	Dado 1/4"	Vite T5/32 X1

<p>H9</p>  <p>x8</p>	<p>H10</p>  <p>x32</p>	<p>H11</p>  <p>x8</p>	<p>H12</p>  <p>x16</p>
<p>Dado 4/32"</p>		<p>Rondella 1/4"x16 mm</p>	
<p>Vite 4/32"</p>		<p>Vite 1/4"x1-1/2"</p>	
<p>H13</p>  <p>x16</p>	<p>H14</p>  <p>x4</p>	<p>A1</p>  <p>x1</p>	<p>A2</p>  <p>x1</p>
<p>Vite esagonale 4/32"</p>		<p>Vite 3,5x1</p>	
<p>Set</p>		<p>Triangolo</p>	
<p>A3</p>  <p>x2</p>	<p>A4</p>  <p>x2</p>	<p>A5</p>  <p>x1</p>	<p>A6</p>  <p>x2</p>
<p>Stecche</p>		<p>Gesso</p>	
<p>Spazzola</p>		<p>Pallina da calcio</p>	
<p>T1</p>  <p>x1</p>	<p>T2</p>  <p>x1</p>		
<p>Chiave a brugola</p>		<p>Chiave inglese</p>	

ZUSAMMENBAU

Assembly | Ensamblaje | Assemblée | Assemblaggio

STEP 1

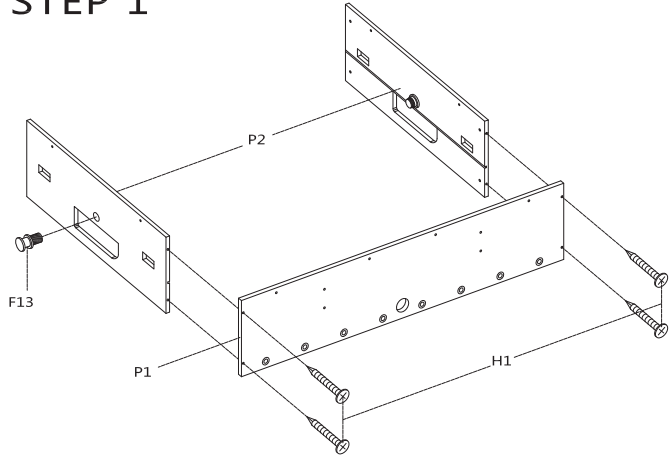

STEP 2

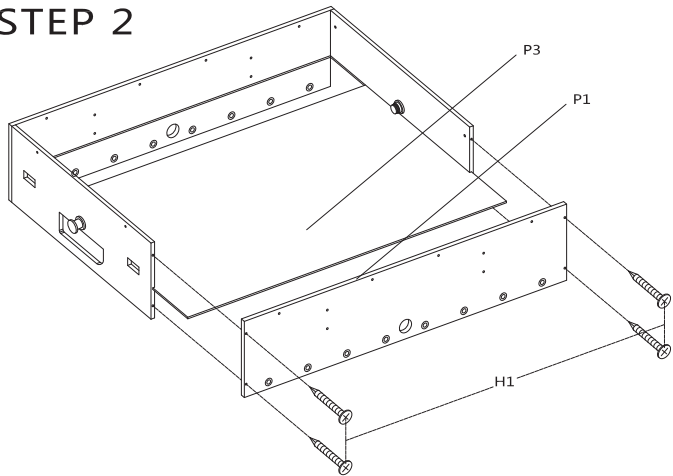

STEP 3

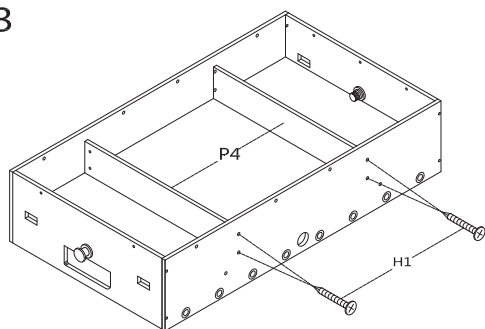

STEP 4

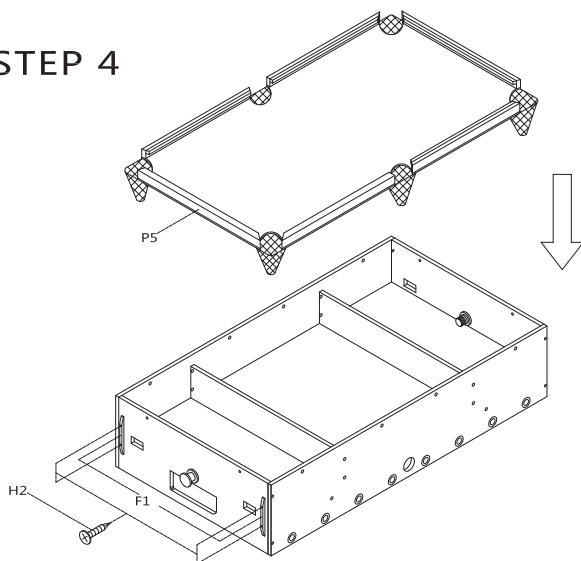

STEP 5

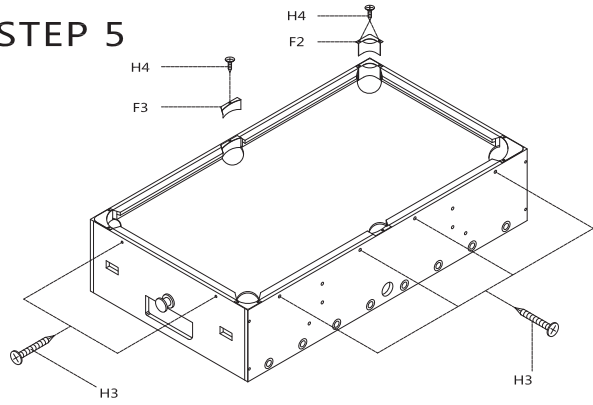

STEP 6

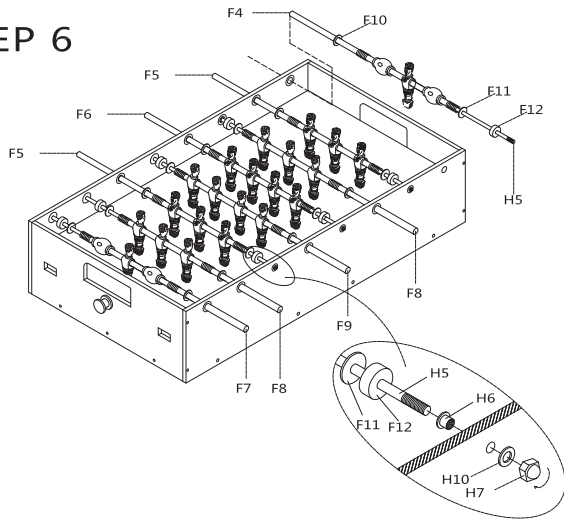

STEP 7

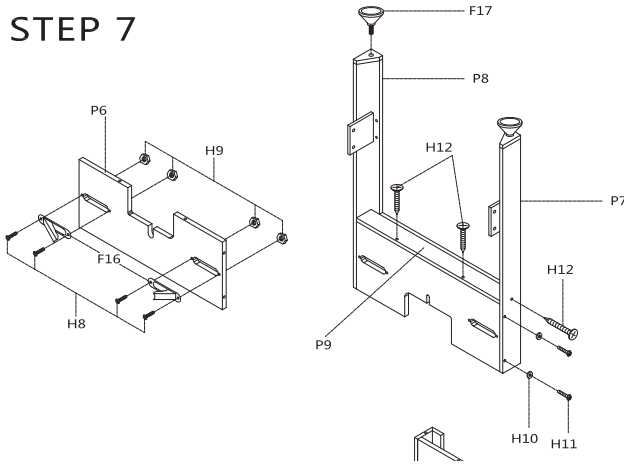

STEP 8

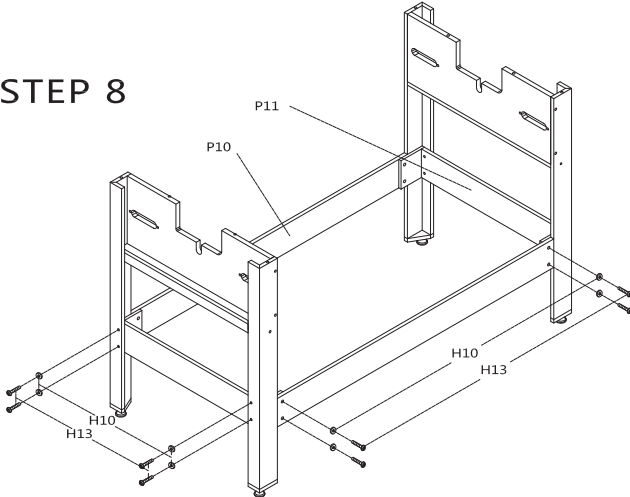

STEP 9

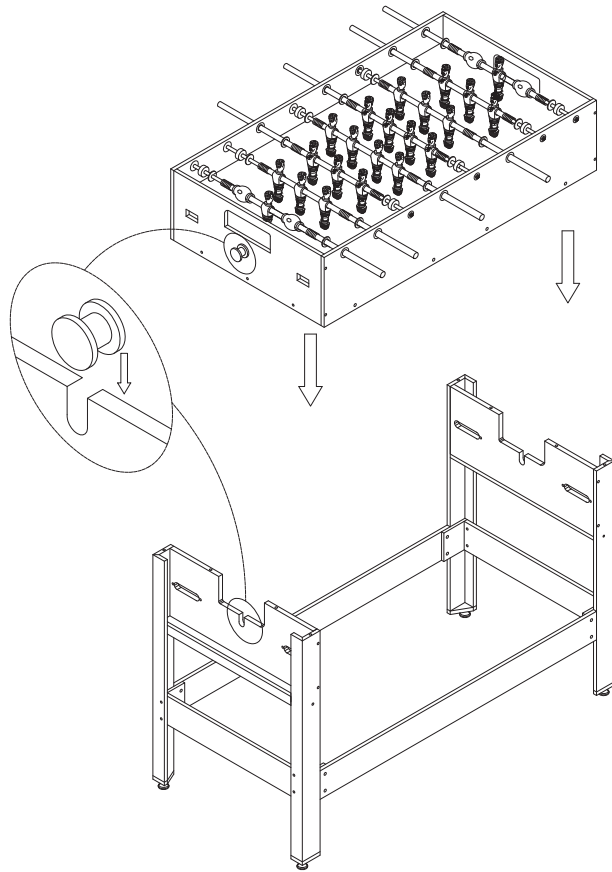

STEP 10

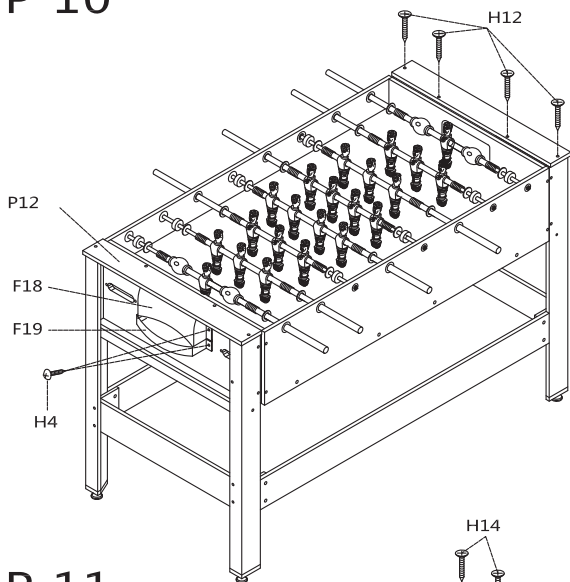

STEP 11

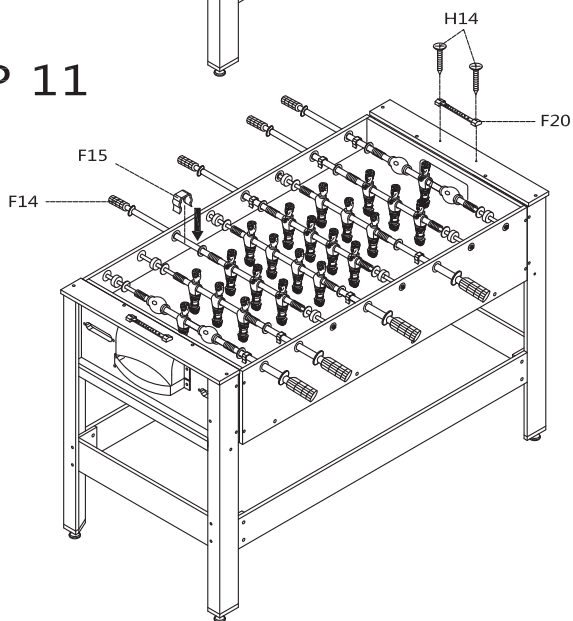

HERSTELLER

Manufacturer | Fabricante | Fabricant | Produttore

Chal-Tec GmbH, Wallstraße 16, 10179 Berlin, Deutschland (Germany).

IMPORTEUR FÜR GROSSBRITANNIEN

Importer for Great Britain | Importador para Gran Bretaña | Importateur pour la Grande Bretagne | Importatore per la Gran Bretagna

Berlin Brands Group UK Ltd
PO Box 1145
Oxford, OX1 9UW
United Kingdom

