

10033570 10033571

## Ultimate Gym 9000

Fitness-Station

Fitness Station

Multiestación de fitness

Station de fitness

Fitness multi-stazione



**Sehr geehrter Kunde,**

bitte überprüfen Sie jetzt die Vollständigkeit der gelieferten Packstücke, bevor Sie mit dem Aufbau des Produktes beginnen. Im Falle eines fehlenden Kartons bitten wir Sie, sich vor dem Öffnen der Kartons mit unserem Kundenservice in Verbindung zu setzen.

**Dear customer,**

Please check the delivered packages to ensure that the delivery is complete before you begin building the product. In case of a missing carton, please contact our customer service before opening the other cartons.

**Estimado cliente:**

Compruebe que haya recibido todas las cajas antes de empezar a montar el producto. En caso de que falte alguna caja, póngase en contacto con nuestro servicio de atención al cliente antes de abrirlas.

**Cher client,**

Veuillez vérifier que les colis livrés sont bien au complet avant de commencer à assembler le produit. En cas d'emballage manquant, veuillez contacter notre service clientèle avant d'ouvrir les autres cartons

**Gentile Cliente,**

La preghiamo di controllare che i colli consegnati siano completi prima di procedere al montaggio del prodotto. Se dovesse mancare un collo, rivolgersi al servizio di assistenza clienti prima di aprire i pacchi.







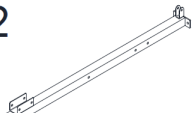
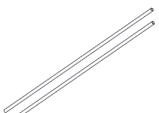

**PACKLISTE | CARTON LIST | LISTA DE PAQUETES | LISTE D'EMBALLAGE | DISTINTA D'IMBALLAGGIO**

				10033570 (black)		10033571 (white)	
Karton Carton Cartón Carton Cartone	Stk. Pc. Uds. Qté Pz.	Abmessungen (cm) Diemnsions (cm) Dimensiones (cm) Dimensions (cm) Dimensioni (cm)	Gewicht (kg) Weight (kg) Peso (kg) Poids (kg) Peso (kg)	SKU	EAN	SKU	EAN
A	1	204,5*43*14	27,8	70000774	4060656158889	70000780	4060656158940
B	1	195*47*13	26	70000775	4060656158896	70000781	4060656158957
C	1	102,5*50*15	28,6	70000776	4060656158902	70000782	4060656158964
D	1	150*55*20	26,6	70000777	4060656158919	70000783	4060656158971
E	3	39*20,5*19,5	27,25	70000778	4060656158926	70000784	4060656158988
F	1	37,5*20,5*19,5	18,2	70000779	4060656158933	70000785	4060656158995

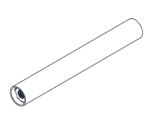
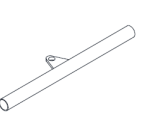
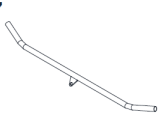
**Karton A | Carton A | Cartón A | Carton A | Cartone A**

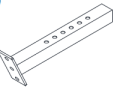
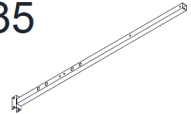
Product colour black: SKU: 70000774 / EAN: 4060656158889











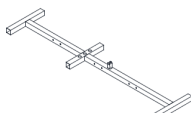
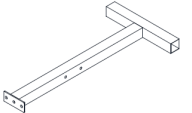
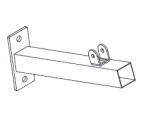

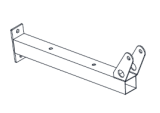
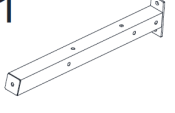



















Product colour white: SKU: 70000780 / EAN: 4060656158940

<b>2</b>  Leg Press Base Frame 1pc	<b>4</b>  Weight Guide Tube 2pcs	<b>6</b>  Support Frame 1pc	<b>15</b>  Handle Tube 4pcs	<b>16</b>  Low Bar 1pc
<b>17</b>  Lat Bar 1pc	<b>19</b>  Leg Press Lower Support Frame 1pc	<b>25</b>  Leg Press Connect Frame 1pc	<b>26</b>  Leg Press Plate Adjust Frame 1pc	<b>35</b>  Rear Upright Frame 1pc
<b>37</b>  Short Foam Tube 1pc	<b>46</b>  Backrest Cushion 2pcs	<b>47</b>  Seat Cushion 2pcs		

**Karton B | Carton B | Cartón B | Carton B | Cartone B**

Product colour black: SKU: 70000775 / EAN: 4060656158896







Product colour white: SKU: 70000781 / EAN: 4060656158957

<p><b>1</b></p>  <p>Base Frame 1pc</p>	<p><b>3</b></p>  <p>VKR Base Frame 1pc</p>	<p><b>7</b></p>  <p>Resist Bar 1pc</p>	<p><b>8</b></p>  <p>Leg Extension Frame 1pc</p>	<p><b>9</b></p>  <p>Seat Frame 1pc</p>
<p><b>21</b></p>  <p>Leg Press Seat Frame 1pc</p>	<p><b>22</b></p>  <p>Leg Press Seat Support Frame 1pc</p>	<p><b>23</b></p>  <p>Front Leg Press Upright Frame 1pc</p>	<p><b>24</b></p>  <p>Rear Leg Press Upright Frame 1pc</p>	<p><b>30</b></p>  <p>Pedal Frame 2pcs</p>
<p><b>46</b></p>  <p>Backrest Cushion 1pc</p>	<p><b>50</b></p>  <p>VKR Arm Cushion 2pcs</p>	<p><b>51</b></p>  <p>Leg Extension Foam 4pcs</p>	<p><b>52</b></p>  <p>Arm Foam Roller 2pcs</p>	<p><b>53</b></p>  <p>Bench Foam 4pcs</p>
<p><b>88</b></p>  <p>Pedal 2pcs</p>				
<p><b>57</b></p>  <p>Weight Selector Pin 1pc</p>	<p><b>58</b></p>  <p>Pothook 4pcs</p>	<p><b>59</b></p>  <p>Bumper (long) 1pc</p>	<p><b>60</b></p>  <p>Bumper (short) 2pcs</p>	<p><b>62</b></p>  <p>Long Chain 1pc</p>
<p><b>63</b></p>  <p>Short Chain 1pc</p>	<p><b>64</b></p>  <p>Knob 1pc</p>	<p><b>66</b></p>  <p>Quick 1pc</p>	<p><b>70</b></p>  <p>Quick Knob 2pcs</p>	<p><b>71</b></p>  <p>Plastic Washer 1pc</p>
<p><b>72</b></p>  <p>Selector Shaft Bushing 1pc</p>	<p><b>73</b></p>  <p>Selector Shaft Pin 1pc</p>	<p><b>74</b></p>  <p>Ankle Strap 1pc</p>	<p><b>76</b></p>  <p>Rubber Cushion 2pcs</p>	<p><b>78</b></p>  <p>50mm Square End Cap 7pcs</p>
<p><b>89</b></p>  <p>Pulley Bushing (small) 8pcs</p>	<p><b>91</b></p>  <p>38mm Round End Cap 2pcs</p>	<p><b>92</b></p>  <p>Plastic Cover 2pcs</p>	<p><b>95</b></p>  <p>Bolt Cap 4PCS</p>	

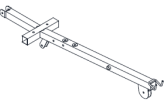
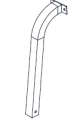
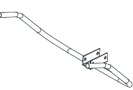
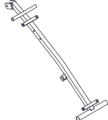
**Karton C | Carton C | Cartón C | Carton C | Cartone C**

Product colour black: SKU: 70000776 / EAN: 4060656158902



















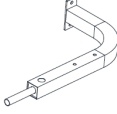





Product colour white: SKU: 70000782 / EAN: 4060656158964

<p><b>18</b></p>  <p>Upper Cross Beam 1pc</p>	<p><b>20</b></p>  <p>Leg Press Upper Support Frame 1pc</p>	<p><b>28</b></p>  <p>Leg Press Hand Bar 1pc</p>	<p><b>29</b></p>  <p>Bench Frame 1pc</p>	<p><b>31</b></p>  <p>VKR Lower Support Frame 1pc</p>
<p><b>43</b></p>  <p>Dumbbell Hook 4pcs</p>	<p><b>49</b></p>  <p>Bench Cushion 1pc</p>	<p><b>56</b></p>  <p>Pulley 15pcs</p>	<p><b>75</b></p>  <p>Dumbbell 2pcs</p>	<p><b>Screw Parts 2PCS</b></p>

**Karton D | Carton D | Cartón D | Carton D | Cartone D**

Product colour black: SKU: 70000777 / EAN: 4060656158919

Product colour white: SKU: 70000783 / EAN: 4060656158971

<p><b>5</b></p>  <p>Selector Shaft 1pc</p>	<p><b>10</b></p>  <p>Arm Frame 1pc</p>	<p><b>11</b></p>  <p>Right Butterfly Arm 1pc</p>	<p><b>12</b></p>  <p>Left Butterfly Arm 1pc</p>	<p><b>13</b></p>  <p>Press Bar 1pc</p>
<p><b>14</b></p>  <p>Long Foam Tube 2pcs</p>	<p><b>27</b></p>  <p>Leg Press Plate 1pc</p>	<p><b>32</b></p>  <p>VKR Upper Support Frame 1pc</p>	<p><b>33</b></p>  <p>Right VKR 1pc</p>	<p><b>34</b></p>  <p>Left VKR 1pc</p>
<p><b>36</b></p>  <p>Bench Handle Tube 1pc</p>	<p><b>38</b></p>  <p>Long Handle Tube 1pc</p>	<p><b>45</b></p>  <p>Cylinder 2pcs</p>	<p><b>48</b></p>  <p>Arm Cushion 1pc</p>	<p><b>67</b></p>  <p>Upper Cable 1pc</p>
<p><b>68</b></p>  <p>Butterfly Cable 1pc</p>	<p><b>69</b></p>  <p>Lower Cable 1pc</p>			
<p><b>39</b></p>  <p>Reverse U 1pc</p>	<p><b>40</b></p>  <p>Pulley U 1pc</p>	<p><b>41</b></p>  <p>Single Pulley Block 2pcs</p>	<p><b>42</b></p>  <p>Plate 1pc</p>	<p><b>44</b></p>  <p>Tobacco-pipe 1pc</p>
<p><b>61</b></p>  <p>Plum Blossom Nut 1pc</p>	<p><b>77</b></p>  <p>Handle Grip 4pcs</p>	<p><b>80</b></p>  <p>Mid-empty Square Plug (□50x□26mm) 2pcs</p>	<p><b>111</b></p>  <p>∅30X∅10 Washer 1pc</p>	

**Karton E | Carton E | Cartón E | Carton E | Cartone E**

Product colour black: SKU: 70000778 / EAN: 4060656158926  
Product colour white: SKU: 70000784 / EAN: 4060656158988

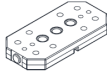
<p><b>55</b></p>  <p>Weight Plate 4pcs</p>				
---	--	--	--	--

**Karton F | Carton F | Cartón F | Carton F | Cartone F**

Product colour black: SKU: 70000779 / EAN: 4060656158933  
Product colour white: SKU: 70000785 / EAN: 4060656158995

<p><b>54</b></p>  <p>Top Weight Plate 1pc</p>	<p><b>55</b></p>  <p>Weight Plate 2pcs</p>			
--	---	--	--	--

**Sehr geehrter Kunde,**

wir gratulieren Ihnen zum Erwerb Ihres Gerätes. Lesen Sie die folgenden Hinweise sorgfältig durch und befolgen Sie diese, um möglichen Schäden vorzubeugen. Für Schäden, die durch Missachtung der Hinweise und unsachgemäßen Gebrauch entstehen, übernehmen wir keine Haftung. Scannen Sie den folgenden QR-Code, um Zugriff auf die aktuellste Bedienungsanleitung und weitere Informationen rund um das Produkt zu erhalten.

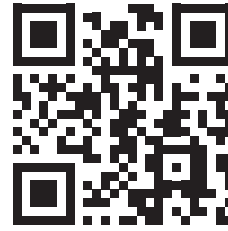

---

## INHALTSVERZEICHNIS

---

Sicherheitshinweise 8  
Übersicht der Einzelteile 9  
Zusammenbau 13  
Installation der Kabel 24  
Aufwärmung vor dem Training 27

English 29  
Español 51  
Français 73  
Italiano 95

---

## HERSTELLER & IMPORTEUR (UK)

---

**Hersteller:**

Chal-Tec GmbH, Wallstraße 16, 10179 Berlin, Deutschland.

**Importeur für Großbritannien:**

Berlin Brands Group UK Limited  
PO Box 42  
272 Kensington High Street  
London, W8 6ND  
United Kingdom

---

## PFLEGE UND WARTUNG

---

**Hinweis:** Wie bei allen Trainingsgeräten mit mechanischen, beweglichen Komponenten kann es auch bei diesem Produkt vorkommen, dass sich Schrauben durch häufigen Gebrauch lockern. Wir empfehlen sie daher regelmäßig zu kontrollieren und ggf. mit einem passenden Schlüssel nachzuziehen. Reinigen Sie Ihr Trainingsgerät regelmäßig mit einem feuchten Tuch, um die Oberflächen von Schweiß und Staub zu säubern.

- Reinigen Sie das Gerät regelmäßig mit einem sauberen Tuch, um das saubere Erscheinungsbild aufrecht zu erhalten.
- Die sichere Verwendung des Geräts kann nur dann gewährleistet werden, wenn das Gerät regelmäßig auf Schäden und Abnutzungen überprüft wird (beispielsweise an Handgriffen, Pedalen, Sattel etc.). Es ist essentiell, dass beschädigte Geräteteile ersetzt werden und das Gerät erst nach erfolgter Reparatur wieder verwendet wird.
- Überprüfen Sie regelmäßig, ob Schrauben und Muttern richtig fixiert sind.
- Fetten Sie bewegliche Geräteteile regelmäßig ein.

## SICHERHEITSHINWEISE



Lesen Sie sich die Bedienungsanleitung vor der Verwendung des Geräts aufmerksam durch und bewahren Sie diese für den zukünftigen Gebrauch auf. Die Produktmerkmale können leicht von den auf den Abbildungen dargestellten Merkmalen abweichen. Veränderungen können vom Hersteller ohne Benachrichtigung vorgenommen werden.







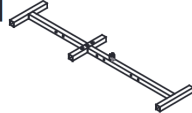









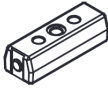





















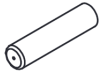



- Bewahren Sie die Bedienungsanleitung an einem sicheren Ort auf, so dass Sie jederzeit auf diese zugreifen können.
- Bauen Sie das Gerät erst dann zusammen, wenn Sie die Bedienungsanleitung vollständig durchgelesen haben. Die Sicherheit und die Effizienz des Geräts können nur dann gewährleistet werden, wenn das Gerät richtig zusammengebaut wurde und fachgerecht gewartet und verwendet wird. Es liegt in Ihrer eigenen Verantwortung sicherzustellen, dass alle Nutzer des Geräts über Warnhinweise und Vorsichtsmaßnahmen informiert werden.
- Das Gerät muss auf einer stabilen und geraden Oberfläche platziert werden, um sicher verwendet werden zu können. Schützen Sie den Boden durch eine Matte. Verwenden Sie das Gerät nicht in feuchter Umgebung, wie beispielsweise an Pools etc. Der Sicherheitsabstand rund um das Gerät muss mindestens 0,6 Meter betragen.
- Konsultieren Sie vor der Verwendung der Trainingsprogramme zwingend einen Arzt, um feststellen zu lassen, ob Sie körperliche oder gesundheitliche Probleme haben, welche durch die Verwendung des Geräts ein Risiko für Ihre Gesundheit und Sicherheit darstellen könnten, oder Sie daran hindern, das Gerät ordnungsgemäß zu verwenden. Der Rat Ihres Arztes ist lebenswichtig, wenn Sie Medikamente einnehmen, welche Einfluss auf Puls, Blutdruck oder den Cholesterinspiegel haben.
- Achten Sie auf die Signale Ihres Körpers. Ein falsches oder übermäßiges Trainieren kann gesundheitsschädigend sein. Hören Sie mit dem Training auf, wenn eines der folgenden Symptome auftritt: Schmerz, Enge in der Brust, unregelmäßiger Herzschlag, extreme Kurzatmigkeit, Schwindel oder Übelkeit. Sollte bei Ihnen einer dieser Zustände auftreten, müssen Sie zwingen einen Arzt konsultieren, bevor Sie das Training fortsetzen können.
- Trainieren Sie nicht direkt im Anschluss an Mahlzeiten.
- Das Gerät darf ausschließlich von Erwachsenen zusammengebaut werden. Halten Sie Kinder und Haustiere vom Gerät fern.
- Das Gerät darf ausschließlich im häuslichen Bereich verwendet werden.
- Das Gerät ist nicht für die therapeutische Verwendung geeignet. Es kann nur für die in der Anleitung dargestellten Übungen verwendet werden.
- Tragen Sie bei der Verwendung des Geräts adäquate Trainingskleidung und Trainingsschuhe. Vermeiden Sie lose Kleidung, da diese sich im Gerät verfangen oder Kleidung, welche Sie in Ihrer Bewegungsfreiheit einschränken könnte.
- Halten Sie Ihren Rücken während des Trainings gerade.
- Überprüfen Sie vor jeder Verwendung des Geräts, ob die Handgriffe, der Sattel, Muttern und Bolzen richtig festgezogen wurden.
- Beachten Sie die maximale Position für anpassbare Geräteteile und gehen Sie nicht über die Markierung „Stopp“ hinaus, da dadurch ein Risiko entstehen würde.
- Verwenden Sie das Gerät nur wie dargestellt. Sollten Sie während des Zusammenbaus oder der Überprüfung defekte Teile feststellen oder während der Verwendung seltsame Geräusche, welche vom Gerät ausgehen hören, stoppen Sie augenblicklich die Verwendung. Verwenden Sie das Gerät erst dann wieder, wenn das Problem behoben wurde.
- Lassen Sie beim Anheben oder Verschieben des Geräts Vorsicht walten, damit Sie Ihren Rücken nicht verletzen. Verwenden Sie immer rückschonende Hebetekniken und suchen Sie sich gegebenenfalls Hilfe einer weiteren Person.
- Alle beweglichen Geräteteile (z.B. Pedale, Handgriffe, Sattel... etc.) müssen wöchentlich gewartet werden. Überprüfen Sie diese vor jeder Verwendung. Sollte etwas kaputt oder lose sein, reparieren oder fixieren Sie das entsprechende Teil sofort. Fahren Sie erst dann mit der Verwendung des Geräts fort, wenn Sie den guten Ausgangszustand wieder hergestellt haben.
- Achten Sie auf das Fehlen eines Freilaufsystems, was ein ernsthaftes Risiko darstellt.
- Halten Sie das Netzstromkabel fern von Wärmequellen.
- Stecken Sie keine Gegenstände in die Geräteöffnungen.
- Schalten Sie das Gerät aus und ziehen Sie den Netzstecker, bevor Sie das Gerät bewegen oder reinigen. Reiben Sie die Oberflächen zur Reinigung mit einem milden Reinigungsmittel und einem feuchten Tuch ab. Verwenden Sie keinesfalls Lösungsmittel.
- Verwenden Sie das Gerät nicht an Orten, welche nicht temperiert sind, wie beispielsweise Garagen, Verandas, Badezimmern, Carports oder im Freien.
- Verwenden Sie das Gerät ausschließlich wie in der Bedienungsanleitung beschrieben.
- Eine inkorrekte Reparatur und strukturelle Modifikationen (z.B. das Entfernen oder Ersetzen von Originalteilen) kann den Gerätenutzer in Gefahr bringen.
- Die Schwungscheibe wird während der Verwendung sehr heiß.
- Aktivieren Sie die Tastensperre, wenn Sie das Gerät nicht verwenden.
- Kinder ab 8 Jahren, psychisch und körperlich eingeschränkte Menschen dürfen das Gerät nur benutzen, wenn sie vorher von einer für Sie verantwortlichen Aufsichtsperson ausführlich mit den Funktionen und den Sicherheitsvorkehrungen vertraut gemacht wurden.
- Achten Sie darauf, dass Kinder nicht mit dem Gerät spielen.
- Prüfen Sie vor der Benutzung die Spannung auf dem Typenschild. Schließen Sie das Gerät nur an Steckdosen an, die der Spannung des Geräts entsprechen.

**Hinweis:** Maximalgewicht des Benutzers: 120 kg.































## ÜBERSICHT DER EINZELTEILE

1 	2 	3 	4 	5 
6 	7 	8 	9 	10 
11 	12 	13 	14 	15 
16 	17 	18 	19 	20 
21 	22 	23 	24 	25 
26 	27 	28 	29 	30 
31 	32 	33 	34 	35 
36 	37 	38 	39 	40 
41 	42 	43 	44 	45 

46 	47 	48 	49 	50 
51 	52 	53 	54 	55 
56 	57 	58 	59 	60 
61 	62 	63 	64 	65 
66 	67 	68 	69 	70 
71 	72 	73 	74 	75 
76 	77 	78 	79 	80 
81 	82 	83 	84 	85 
86 	87 	88 	89 	90 

Nr.	Bezeichnung	Stk.	Nr.	Bezeichnung	Stk.
1	Grundrahmen	1	46	Rückenlehnenpolster	3
2	Beinpresse Grundrahmen	1	47	Sitzkissen	2
3	Grundrahmen	1	48	Armkissen	1
4	Gewicht-Führungsrohr	4	49	Bankkissen	1
5	Gewichtschlitten	1	50	Armkissen	2
6	Unterstützungsrahmen	1	51	Beinstreckerpolster	4
7	Widerstandsstange	1	52	Schaumstoffrolle für die Arme	2
8	Beinstrecker	1	53	Schaumstoffrollen	4
9	Sitzrahmen	1	54	Obere Gewichtplatte	1
10	Armrahmen	1	55	Gewichtplatten	14
11	Rechte Butterflyarm	1	56	Riemenscheibe	15
12	Linke Butterflyarm	1	57	Gewichtswahlstift	1
13	Pressleiste	1	58	Karabiner	4
14	Langes Schaumstoffrohr	2	59	Stoßdämpfer (lang)	1
15	Griffrohr	4	60	Stoßdämpfer (kurz)	2
16	Unteres Rohr	1	61	Feststellschraube	1
17	Latzugstange	1	62	Lange Kette	1
18	Oberer Querbalken	1	63	Kurze Kette	1
19	Untere Stütze (Beinpresse)	1	64	Feststellschraube	1
20	Obere Stütze (Beinpresse)	1	65	Ölbuchse	2
21	Sitzrahmen (Beinpresse)	1	66	Sicherheitspin	1
22	Sitzträgerrahmen (Beinpresse)	1	67	Oberes Kabel	1
23	Vorderbeinpresse aufrechter Rahmen	1	68	Butterfly-Kabel	1
24	Hinterbeinpresse aufrechter Rahmen	1	69	Unteres Kabel	1
25	Beinpresse Verbindungsrahmen	1	70	Einstellknopf	2
26	Beinpresse Platten-Einstellrahmen	1	71	Unterlegscheibe	1
27	Beinpresse Platte	1	72	Kunststoffring	1
28	Beinpresse Handlauf	1	73	Stift	1
29	Bankrahmen	1	74	Band	1
30	Pedalrahmen	2	75	Kurzhandtel	2
31	Unterer Stützrahmen	1	76	Gummischeibe	2
32	Oberer Stützrahmen	1	77	Handgriff	18
33	Rechter Bogen	1	78	50 mm Vierkant Endkappe	7
34	Linker Bogen	1	79	Endkappe	1
35	Hinterer aufrechter Rahmen	1	80	Mittlerer Vierkantstopfen	4
36	Bankgriffrohr	1	81	50 mm Vierkantstopfen	8
37	Kurzes Schaumrohr	1	82	38 mm Vierkantstopfen	2
38	Langes Griffrohr	1	83	30x60 mm Vierkant Endkappe	2
39	Doppeltes U-Stück gedreht	1	84	25x50 mm Vierkant Endkappe	2
40	Doppeltes U-Stück	1	85	Pedalkappe (groß)	4
41	Einzelnes U-Stück	2	86	25 mm Runde Endkappe	8
42	Platte	1	87	Mittlerer Vierkantstopfen	2
43	Kurzhandtelhaken	4	88	Pedal	2
44	Bolzen (in Form einer Tabakpfeife)	1	89	Buchse (klein)	8
45	Zylinder	2	90	Kunststoffbuchse	4

Kleinteile

91 	92 	93 	94 	95 
96 	97 	98 	99 	100 
101 	102 	103 	104 	105 
106 	107 	108 	109 	110 
111 	112 	113 	114 	115 
116 	117 	118 		

Nr.	Bezeichnung	Stk.	Nr.	Bezeichnung	Stk.
91	38 mm Runde Endkappe	2	105	M10x20 mm Schraube	4
92	Kunststoffabdeckung	2	106	M8x65 mm Sechskantschraube	16
93	38 mm Vierkantkappe	1	107	M8x40 mm Sechskantschraube	4
94	Pufferkappe	2	108	M8x16mm Sechskantschraube	10
95	Schraubkappe	4	109	M6x40 mm Schraube	4
96	M12x150 mm Sechskantschraube	1	110	M12 Unterlegscheibe	4
97	M12x75 mm Sechskantschraube	1	111	Ø30xØ10 Unterlegscheibe	1
98	M10x85 mm Sechskantschraube	2	112	M10 Unterlegscheibe	111
99	M10 x 75 mm Sechskantschraube	6	113	Ø25xØ8 Unterlegscheibe	4
100	M10x70 mm Sechskantschraube	29	114	M8 Unterlegscheibe	32
101	M10x65 mm Sechskantschraube	2	115	M6 Unterlegscheibe	4
102	M10x45 mm Sechskantschraube	11	116	M12 Nylonmutter	2
103	M10x25 mm Sechskantschraube	2	117	M10 Nylonmutter	52
104	M10x20 mm Sechskantschraube	7	118	M8 Nylonmutter	6

## ZUSAMMENBAU

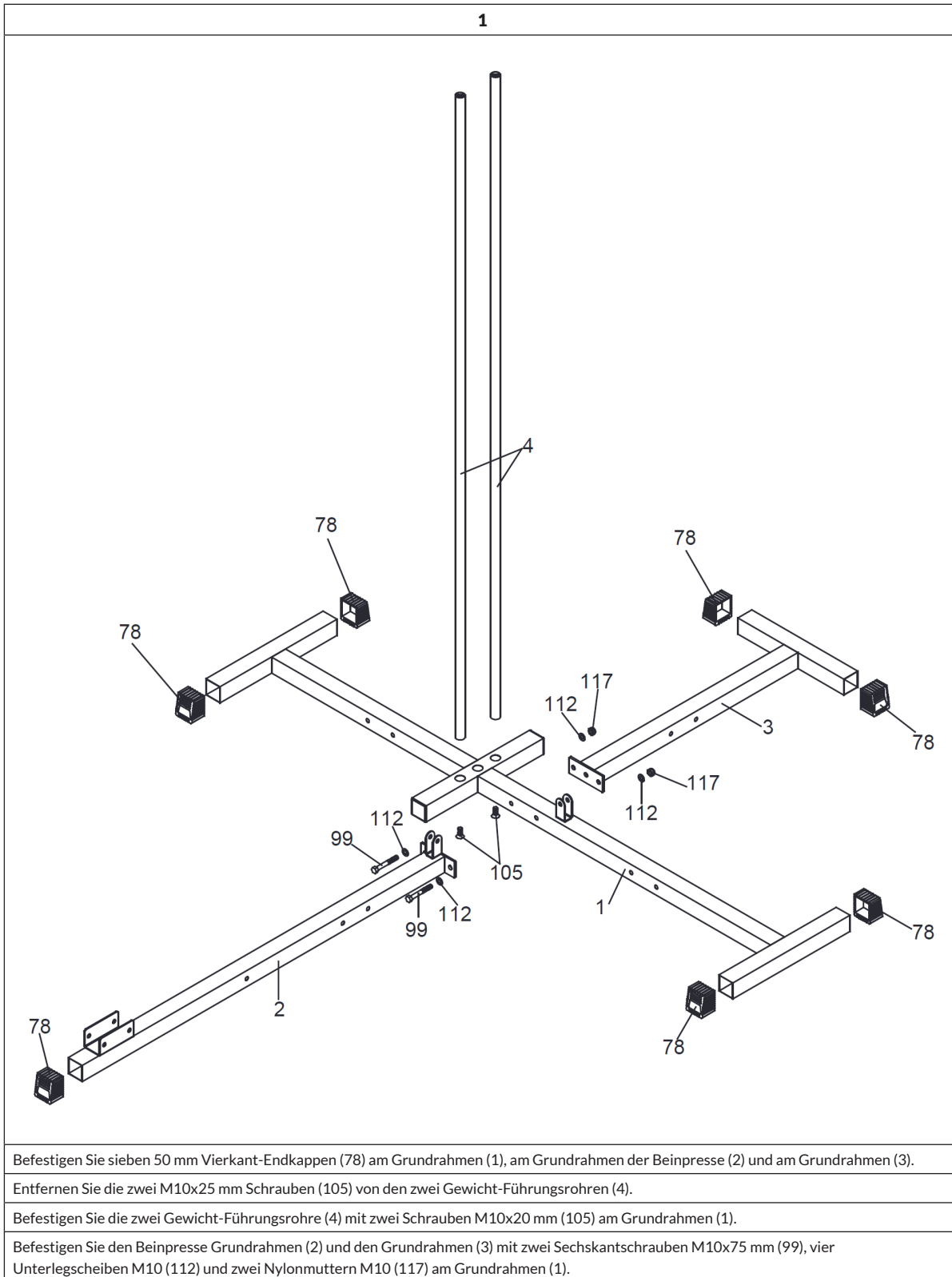

Befestigen Sie sieben 50 mm Vierkant-Endkappen (78) am Grundrahmen (1), am Grundrahmen der Beinpresse (2) und am Grundrahmen (3).

Entfernen Sie die zwei M10x25 mm Schrauben (105) von den zwei Gewicht-Führungsrohren (4).

Befestigen Sie die zwei Gewicht-Führungsrohre (4) mit zwei Schrauben M10x20 mm (105) am Grundrahmen (1).

Befestigen Sie den Beinpresse Grundrahmen (2) und den Grundrahmen (3) mit zwei Sechskantschrauben M10x75 mm (99), vier Unterlegscheiben M10 (112) und zwei Nylonmutter M10 (117) am Grundrahmen (1).

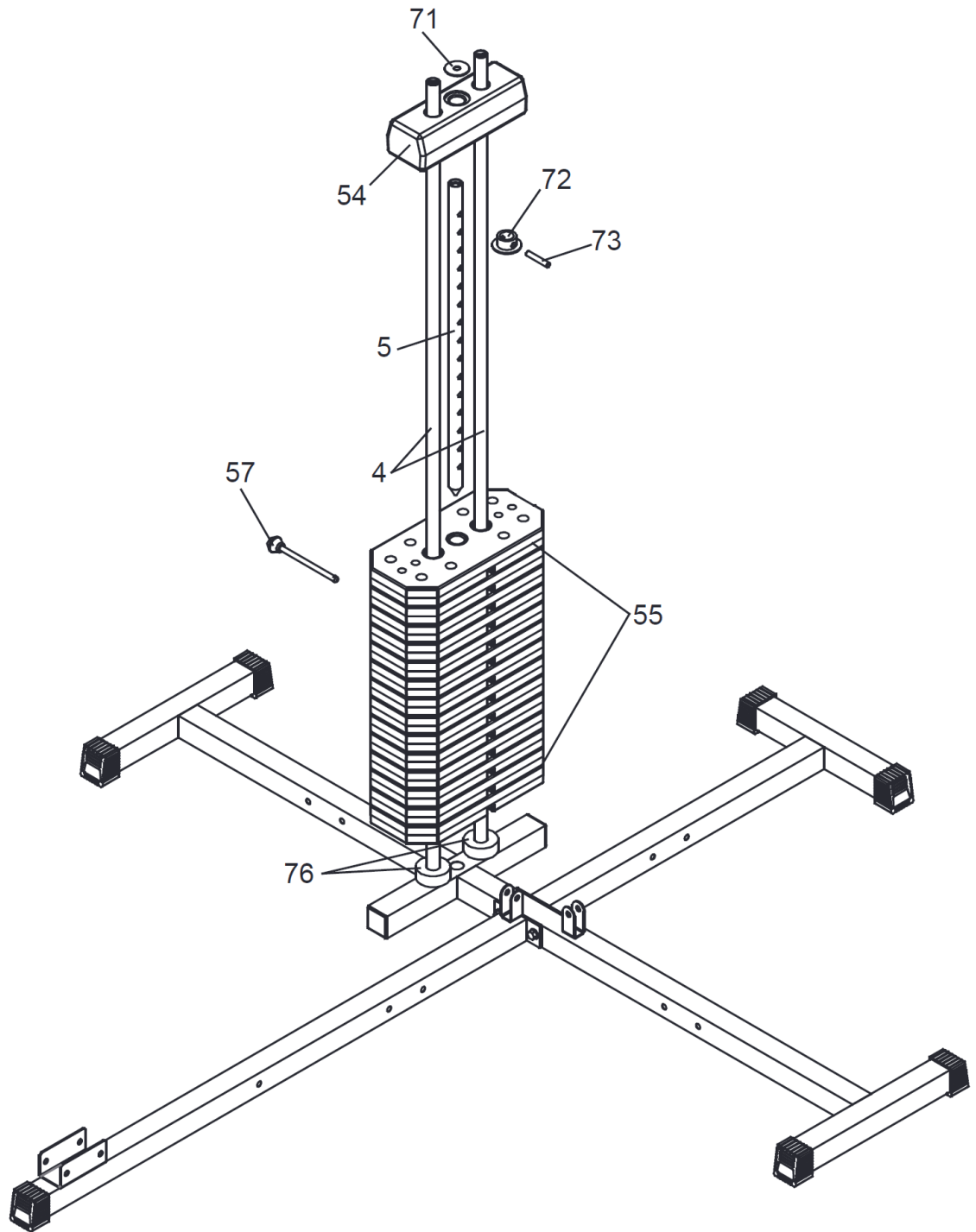

Schieben Sie die zwei Gummischeiben (76) über das Führungsrohr (4).

Schieben Sie die 14 Gewichtplatten (55) über das Führungsrohr (4).

Schieben Sie den Kunststoffring (72) entlang des Gewichtsschlittens (5) nach unten und befestigen Sie ihn mit dem Stift (73) am obersten Loch.

Setzen Sie den Gewichtsschlittens (5) in die Bohrung der Gewichtplatten (55) ein.

Schieben Sie die obere Gewichtplatte (54) auf das Führungsrohr (4) und stecken Sie den Gewichtswahlstift (57) in das Loch des Wunschgewichts.

Setzen Sie die Unterlegscheibe (71) auf die obere Gewichtplatte (54).

3

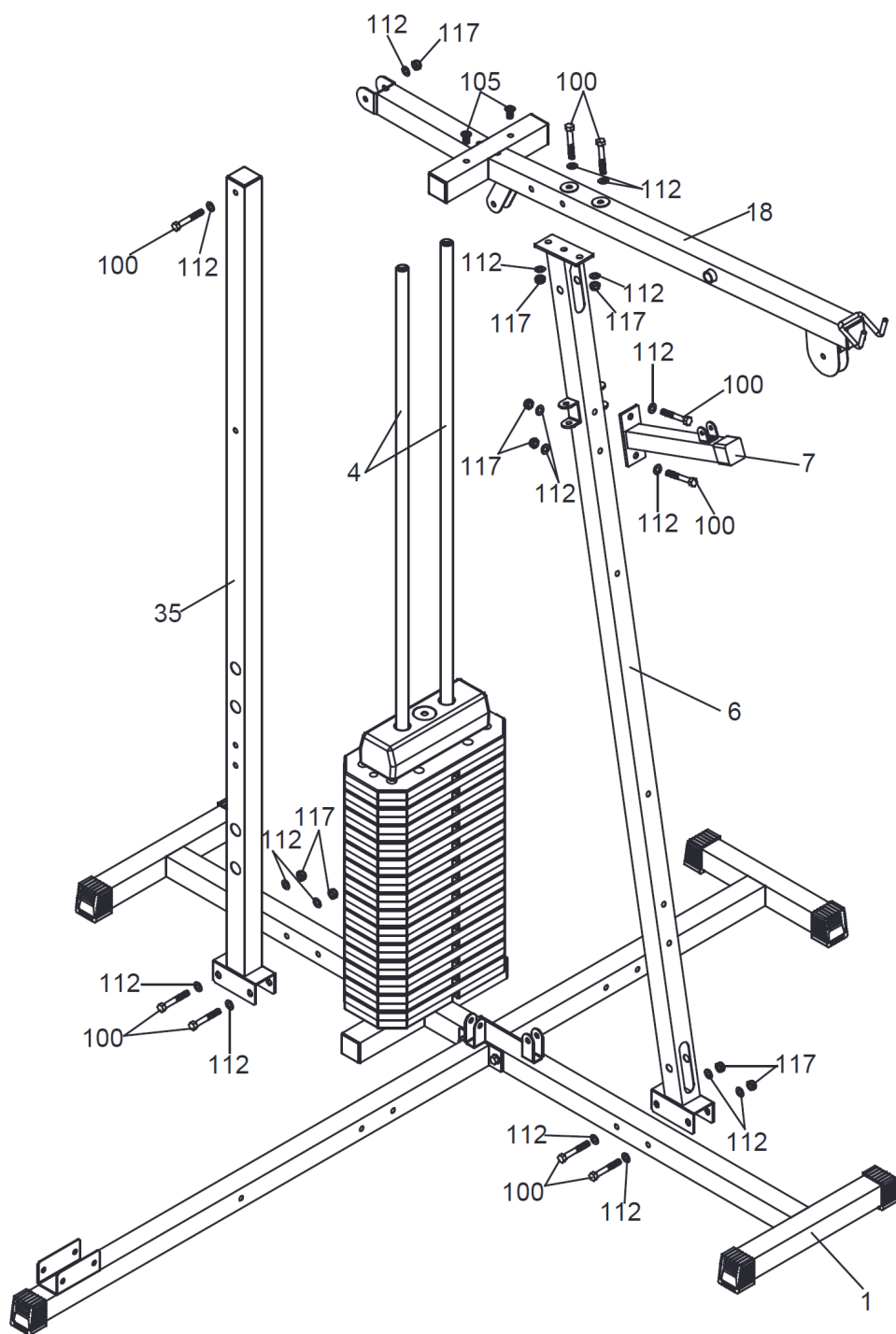

Befestigen Sie den Unterstützungsrahmen (6) und den hinteren aufrechten Rahmen (35) mit vier Sechskantschrauben M10x70 mm (100), acht M10-Scheiben (112) und vier M10-Nylonmuttern (117) am Grundrahmen (1).

Entfernen Sie die zwei M10x25 mm Schrauben (105) von den zwei Führungsrohren (4).

Befestigen Sie den oberen Querbalken (18) mit zwei Schrauben M10x25 mm (105) an den beiden Führungsrohren (4).

Befestigen Sie den oberen Querbalken (18) mit drei Sechskantschrauben M10x70 mm (100), sechs Unterlegscheiben M10 (112) und drei Nylonmuttern M10 (117) am Unterstützungsrahmen (6) und am hinteren aufrechten Rahmen (35).

Befestigen Sie die Widerstandsstange (7) mit zwei Sechskantschrauben M10x70 mm (100), vier M10 Unterlegscheiben (112) und zwei M10-Nylonmuttern (117) am Unterstützungsrahmen (6).

4

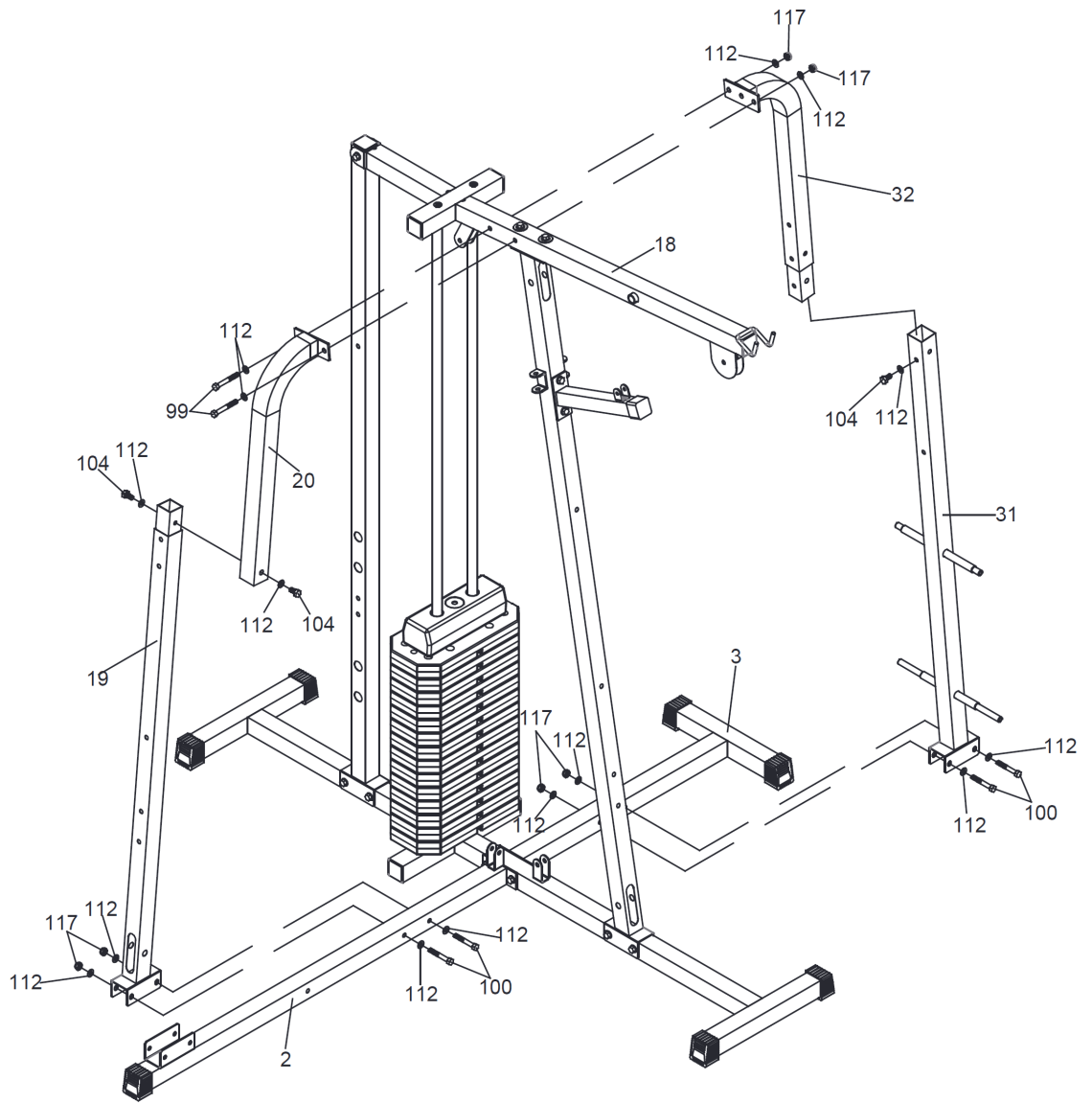

Befestigen Sie die untere Stütze (19) der Beinpresse mit zwei Sechskantschrauben M10x70 mm (100), vier Unterlegscheiben M10 (112) und zwei Nylonmuttern M10 (117) am Grundrahmen (2) der Beinpresse.

Befestigen Sie den unteren Stützrahmen (31) mit zwei Sechskantschrauben M10x70 mm (100), vier M10-Scheiben (112) und zwei M10-Nylonmuttern (117) am Grundrahmen (3).

Befestigen Sie die obere Stütze (20) der Beinpresse mit zwei Sechskantschrauben M10x20 mm (104) und zwei Unterlegscheiben M10 (112) am unteren Stützrahmen (19) der Beinpresse.

Befestigen Sie den oberen Stützrahmen (32) mit einer Sechskantschraube M10x20 mm (104) und einer Unterlegscheibe M10 (112) am unteren Stützrahmen (31).

Befestigen Sie obere Stütze (20) der Beinpresse und den oberen Stützrahmen (32) mit zwei Sechskantschrauben M10x75 mm (99), vier Unterlegscheiben M10 (112) und zwei Nylon-Muttern M10 (117) am oberen Querbalken (18).



5

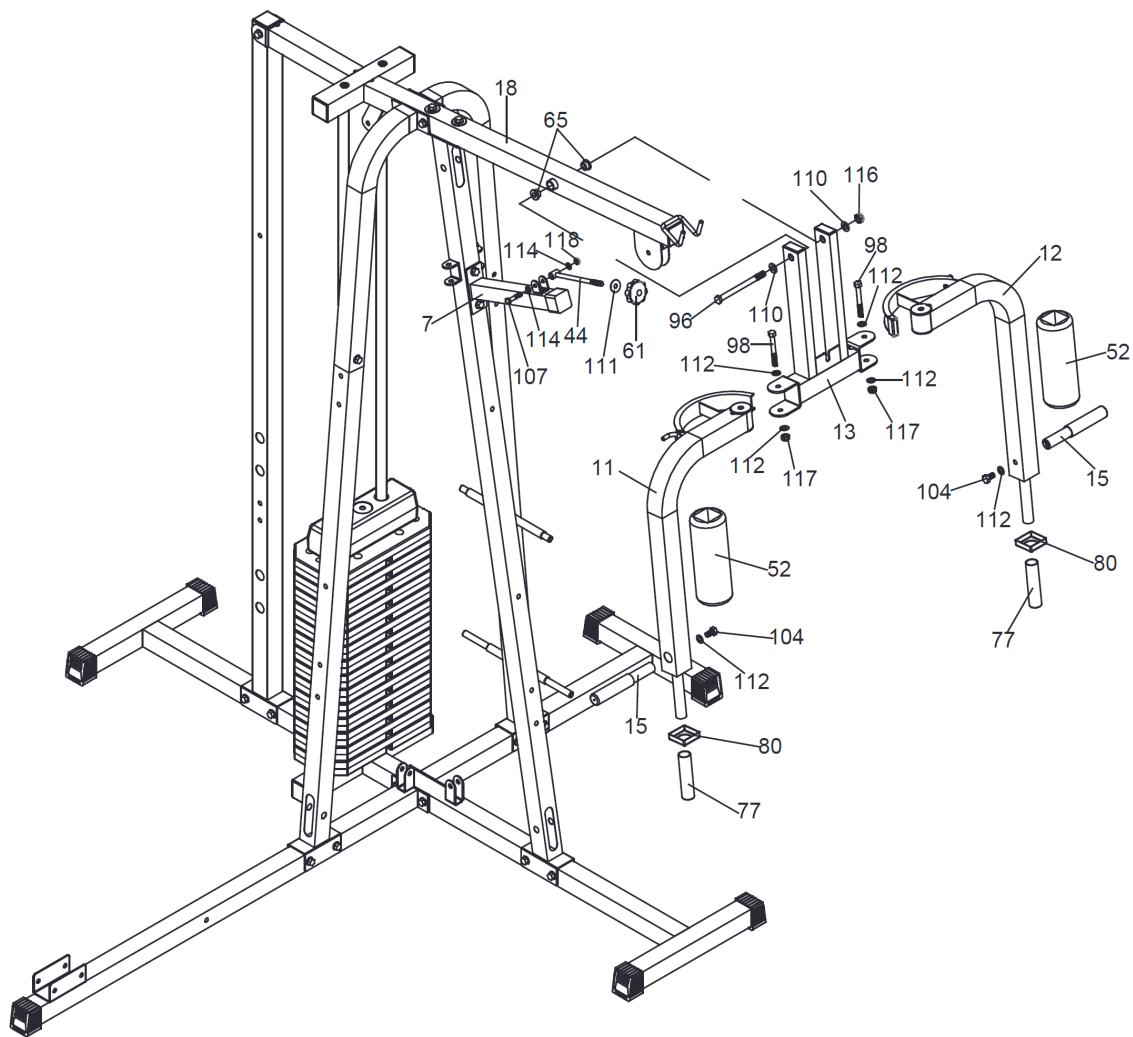

**Hinweis:** Die Ölbuchse (65) ist am oberen Querbalken (18) vormontiert.

Befestigen Sie die Pressleiste (13) mit einer M12x150 mm Sechskantschraube (96), zwei M12 Unterlegscheiben (110) und einer M12 Nylonmutter (116) am oberen Querbalken (18).

Befestigen Sie den linken und rechten Butterflyarm (11&12) mit zwei M10x85mm Sechskantschrauben (98), vier M10 Unterlegscheiben (112) und zwei M10 Nylonmuttern (117) an der Pressleiste (13).

Schieben Sie zwei Schaumstoffrollen (52) auf den linken und rechten Butterflyarm (11&12).

Entfernen Sie die zwei M10x20 mm Sechskantschrauben (104) und zwei M10-Unterlegscheiben (112) von den beiden Griffrohren (15).

Befestigen Sie beiden Griffrohre (15) mit zwei Sechskantschrauben M10x20 mm (104) und zwei Unterlegscheiben M10 (112) am linken und rechten Butterflyarm (11&12).

Schieben Sie die beiden mittleren Vierkantstopfen (80) und die zwei Griffe (77) auf den linken und rechten Butterflyarm (11&12).

Befestigen Sie den Bolzen (44) mit einer Sechskantschraube M8x40 mm (107), zwei Unterlegscheiben M8 (114) und einer Mutter M8 (118) an der Widerstandsstange (7).

Schieben Sie die Unterlegscheibe (111) und die Feststellschraube (61) auf den Bolzen (44).

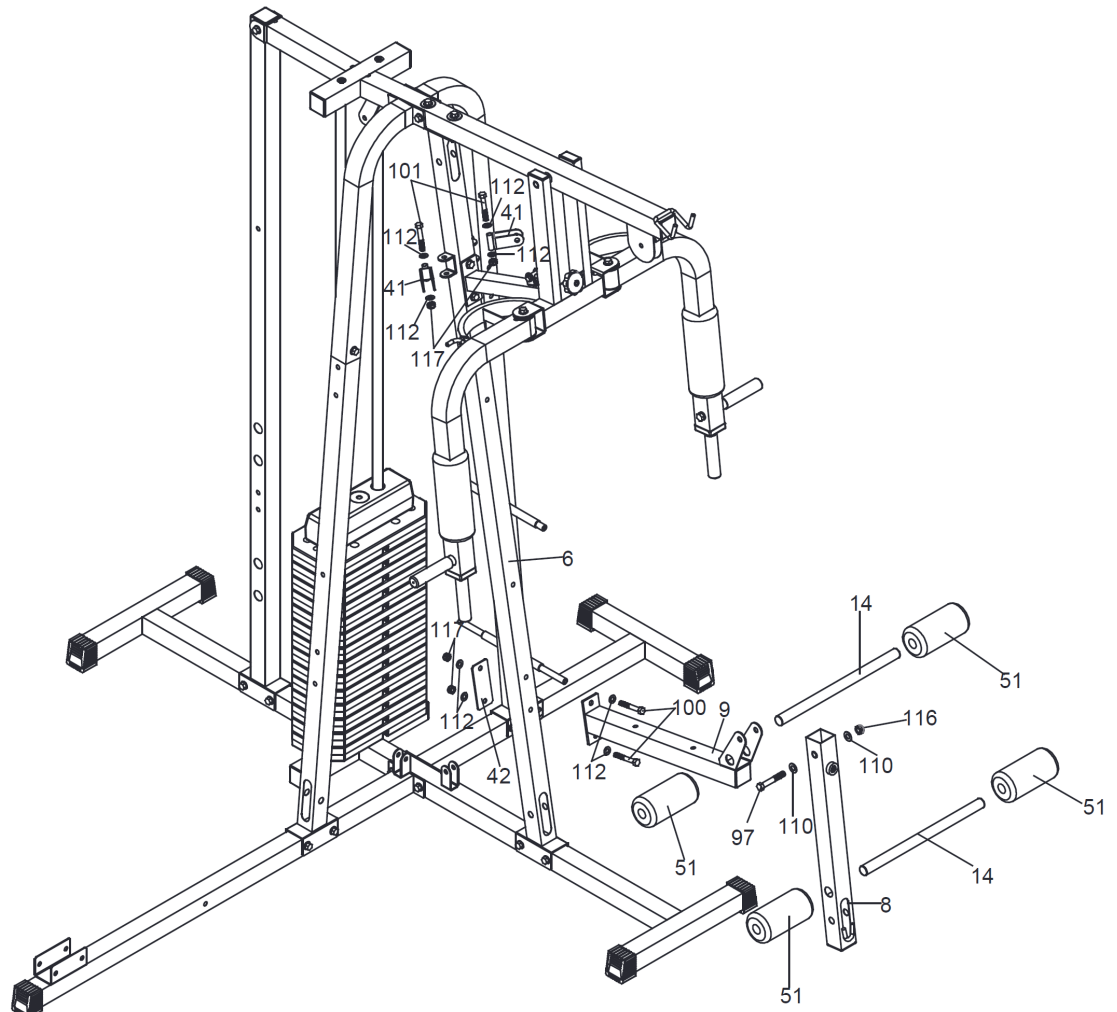

Befestigen Sie den Sitzrahmen (9) und die Platte (42) mit zwei Sechskantschrauben M10x70 mm (100), vier Unterlegscheiben M10 (112) und zwei Nylonmuttern M10 (117) am Unterstützungsrahmen (6).

Befestigen Sie den Beinstrecker (8) mit einer M12x75 mm Sechskantschraube (97), zwei M12-Scheiben (110) und einer M12-Nylonmutter (116) am Sitzrahmen (9).

Setzen Sie die beiden langen Schaumstoffrohre (14) in den Beinstrecker (8) und den Sitzrahmen (9) ein.

Schieben Sie die Beinstreckerpolster (51) auf die langen Schaumstoffrohre (14).

Befestigen Sie das U-Stück (41) mit zwei Sechskantschrauben M10x65 mm (101), vier M10-Scheiben (112) und zwei M10-Nylonmuttern (117) am Unterstützungsrahmen (6).

7

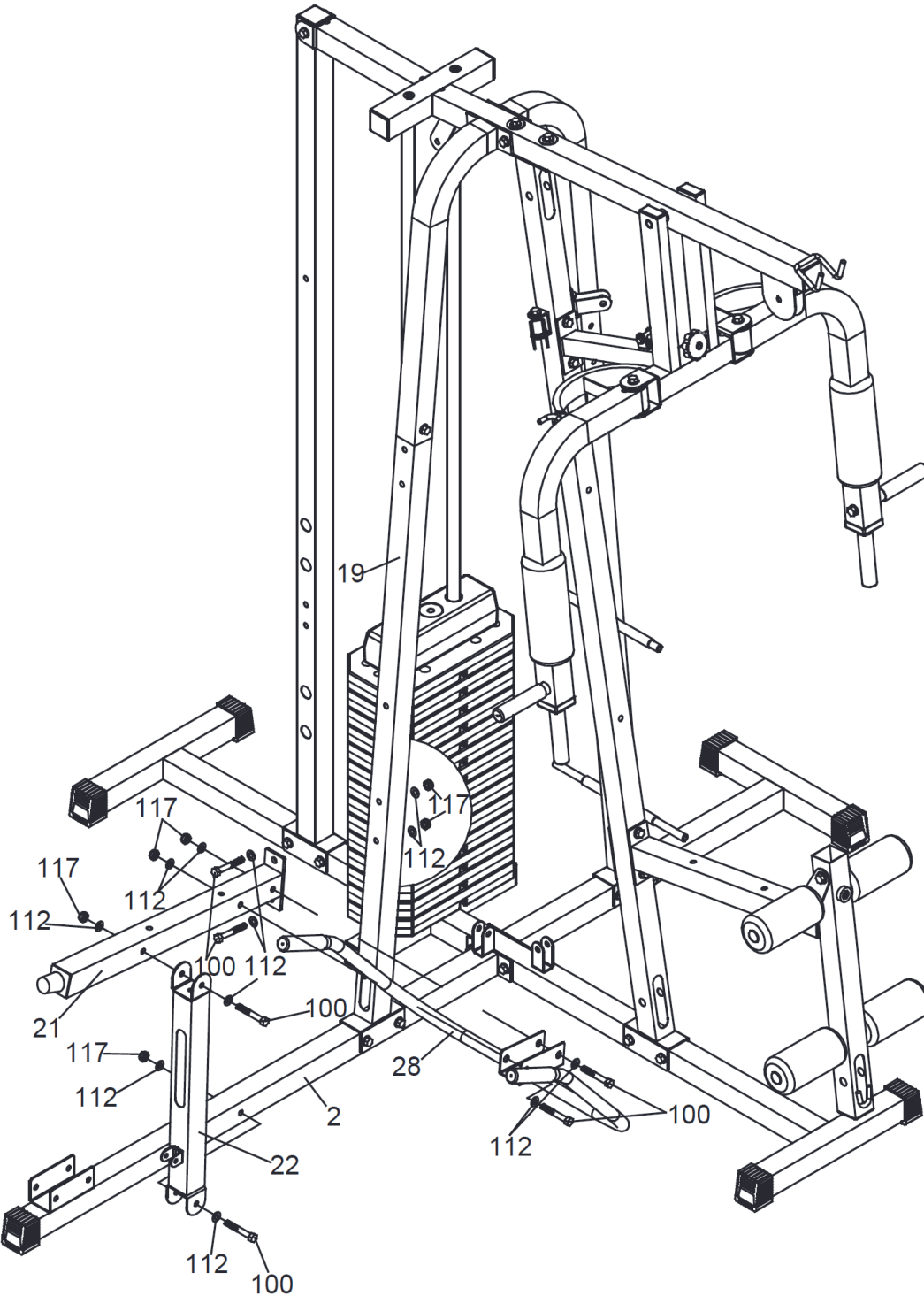

Befestigen Sie den Sitzträgerrahmen (22) der Beinpresse mit einer Sechskantschraube M10x70 mm (100), zwei Unterlegscheiben M10 (112) und einer Nylonmutter M10 (117) am Grundrahmen (2) der Beinpresse.

Befestigen Sie den Sitzrahmen (21) mit drei Sechskantschrauben M10x70 mm (100), sechs Unterlegscheiben M10 (112) und drei Nylonmuttern M10 (117) am der unteren Stütze (19) und am Sitzträgerrahmen (22) der Beinpresse.

Befestigen Sie den Handlauf (28) mit zwei Sechskantschrauben M10x70 mm (100), vier Unterlegscheiben M10 (112) und zwei Nylonmuttern M10 (117) am Sitzrahmen (21).

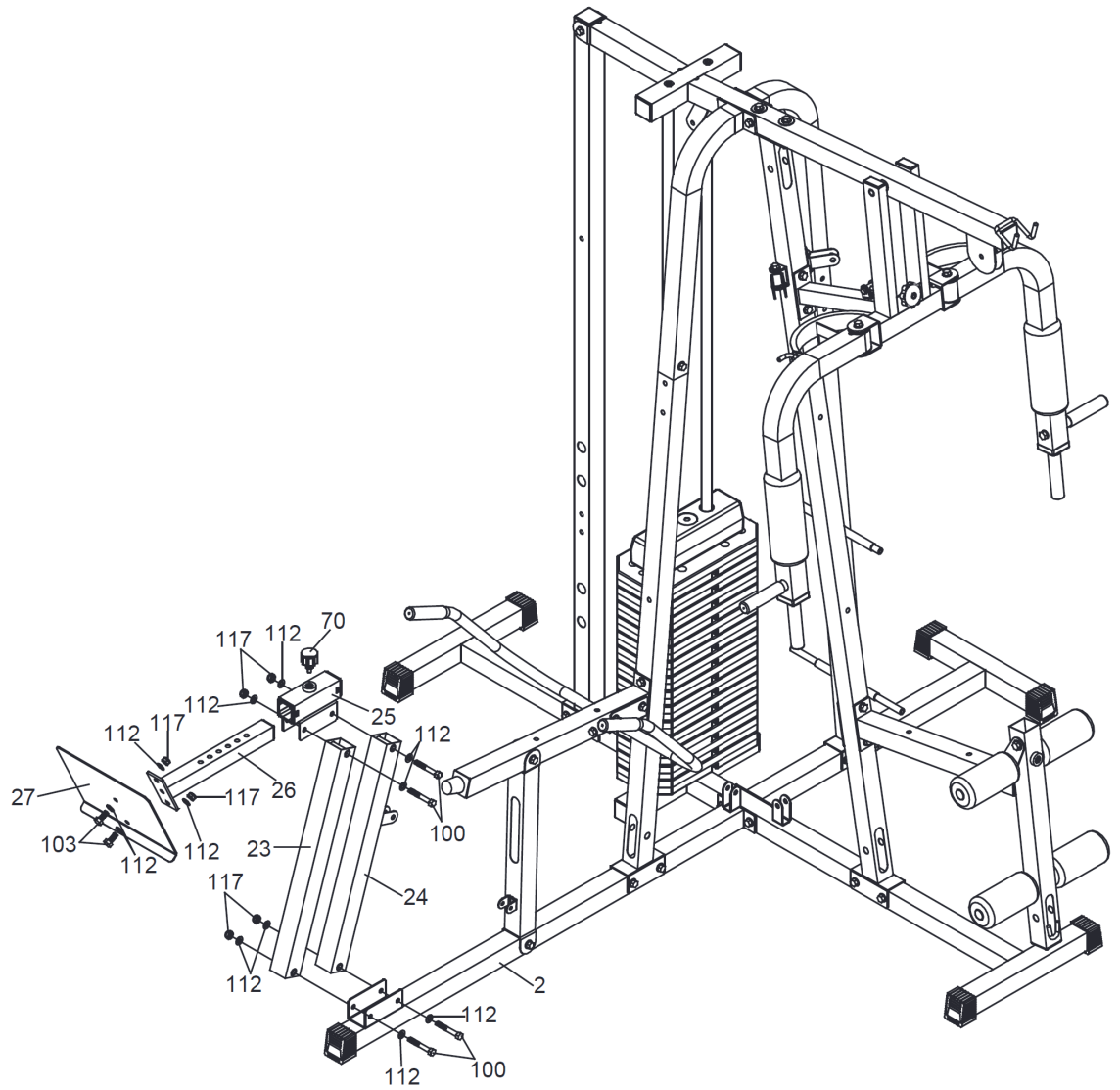

Befestigen Sie den vorderen aufrechten Rahmen (23) und den hinteren aufrechten Rahmen (24) mit zwei Sechskantschrauben M10x70 mm (100), vier Unterlegscheiben M10 (112) und zwei Nylonmuttern M10 (117) am Beinpresse Grundrahmen (2).

Befestigen Sie den Verbindungsrahmen (25) mit zwei Sechskantschrauben M10x70 mm (100), vier Unterlegscheiben M10 (112) und zwei Nylonmuttern M10 (117) am vorderen (23) und hinteren aufrechten Rahmen (24) .

Befestigen Sie die Beinpresse Platte (27) mit zwei Sechskantschrauben M10x25 mm (103), vier Unterlegscheiben M10 (112) und zwei Nylonmuttern M10 (117) am Einstellrahmen (26) der Beinpresse.

Setzen Sie den Einstellrahmen (26) in den Verbindungsrahmen (25) der Beinpresse ein und befestigen Sie den Einstellknopf (70).

9

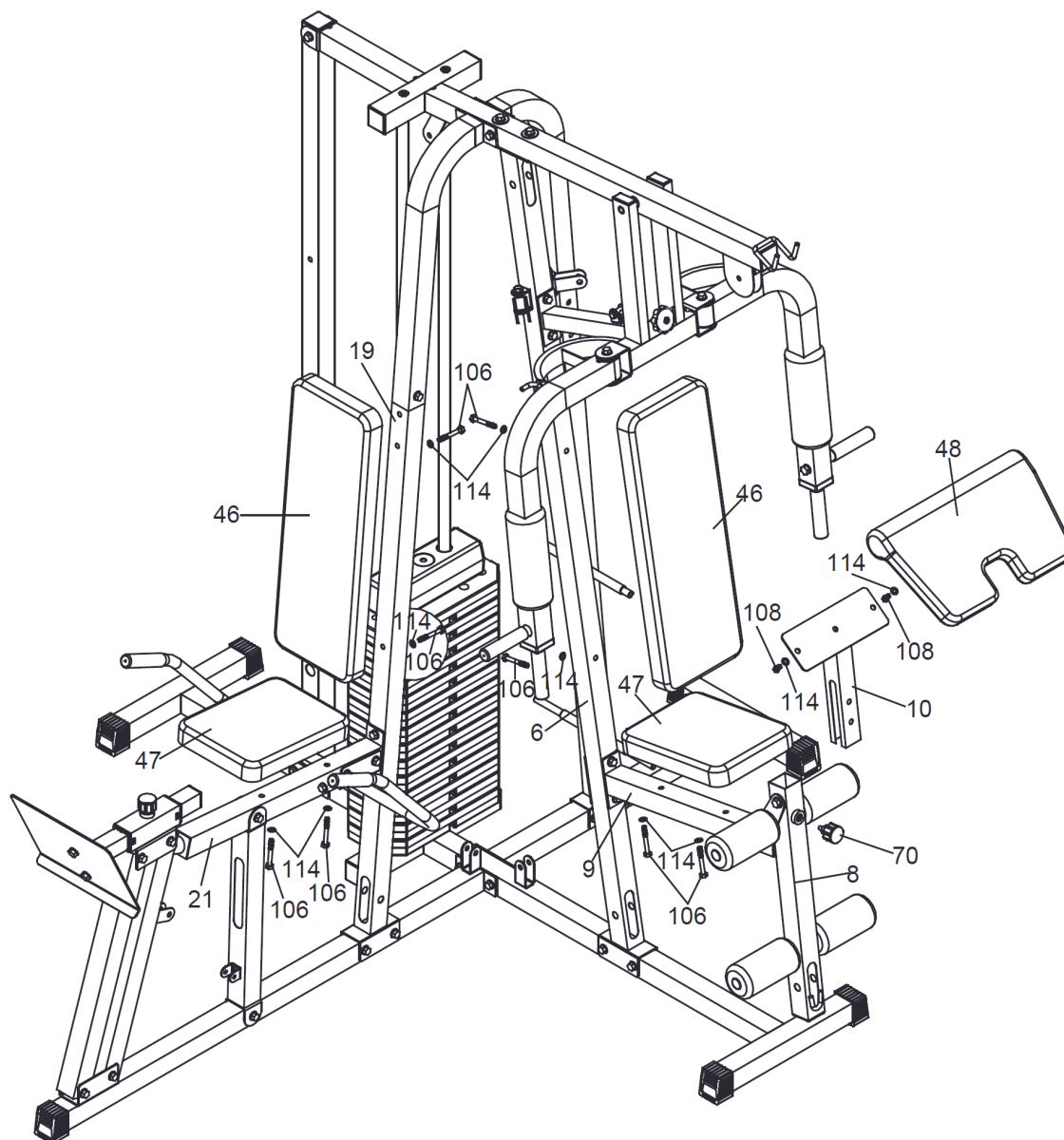

Befestigen Sie die beiden Rückenlehnenpolster (46) mit vier Sechskantschrauben M8x65 mm (106) und vier Unterlegscheiben M8 (114) am Unterstützungsrahmen (6) und an der unteren Stütze (19).

Befestigen Sie die beiden Sitzkissen (47) mit vier Sechskantschrauben M8x65 mm (106) und vier Unterlegscheiben M8 (114) am Sitzrahmen (9) und am Beinpresse Sitzrahmen (21).

Befestigen Sie das Armkissen (48) mit zwei Sechskantschrauben M8x16 mm (108) und zwei Unterlegscheiben M8 (114) am Armrahmen (10).

Setzen Sie den Armrahmen (10) in den Beinstrecker (8) ein und befestigen Sie ihn mit dem Einstellknopf (70).

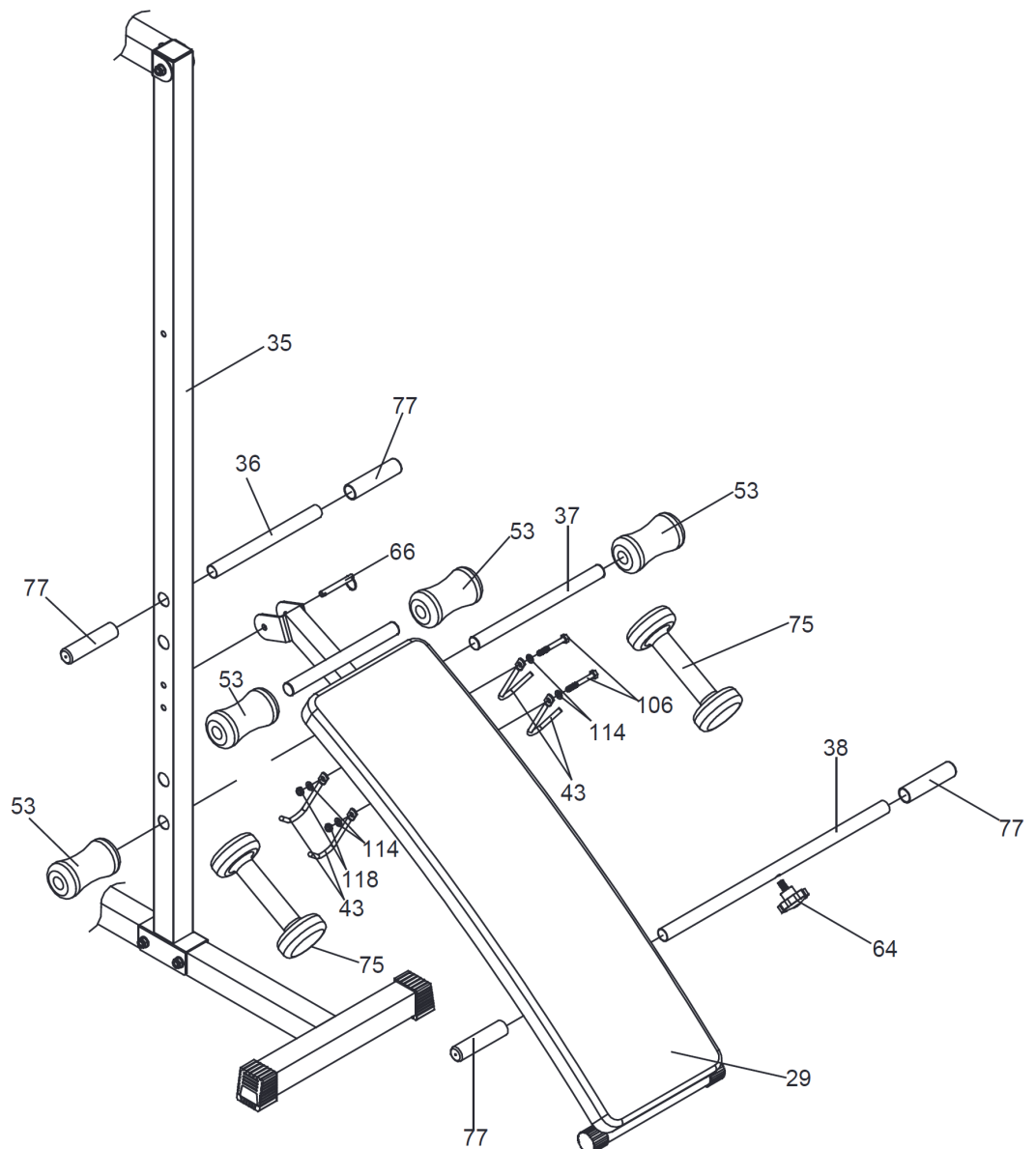

Befestigen Sie die vier Kurzhantelhaken (43) mit zwei Sechskantschrauben M8x65 mm (106), vier Unterlegscheiben M8 (114) und zwei Nylonmuttern M8 (118) am Bankrahmen (29). Legen Sie die beiden Kurzhanteln (75) auf die Haken.

Setzen Sie das lange Griffrohr (38) in den Bankrahmen (29) ein und befestigen Sie die Feststellschraube (64). Schieben Sie beiden Handgriffe (77) auf das Griffrohr (38).

Befestigen Sie den Bankrahmen (29) mit dem Sicherheitspin (66) am hinteren aufrechten Rahmen (35).

Schieben Sie das Bankgriffrohr (36) in den hinteren aufrechten Rahmen (35) einsetzen. Schieben Sie die beiden (77) auf das Bankgriffrohr (36).

Setzen Sie das kurze Schaumstoffrohr (37) in den Bankrahmen (29) ein. Schieben Sie die vier Schaumstoffrollen (53) auf das lange Rohr (37) und den Bankrahmen (29).

11

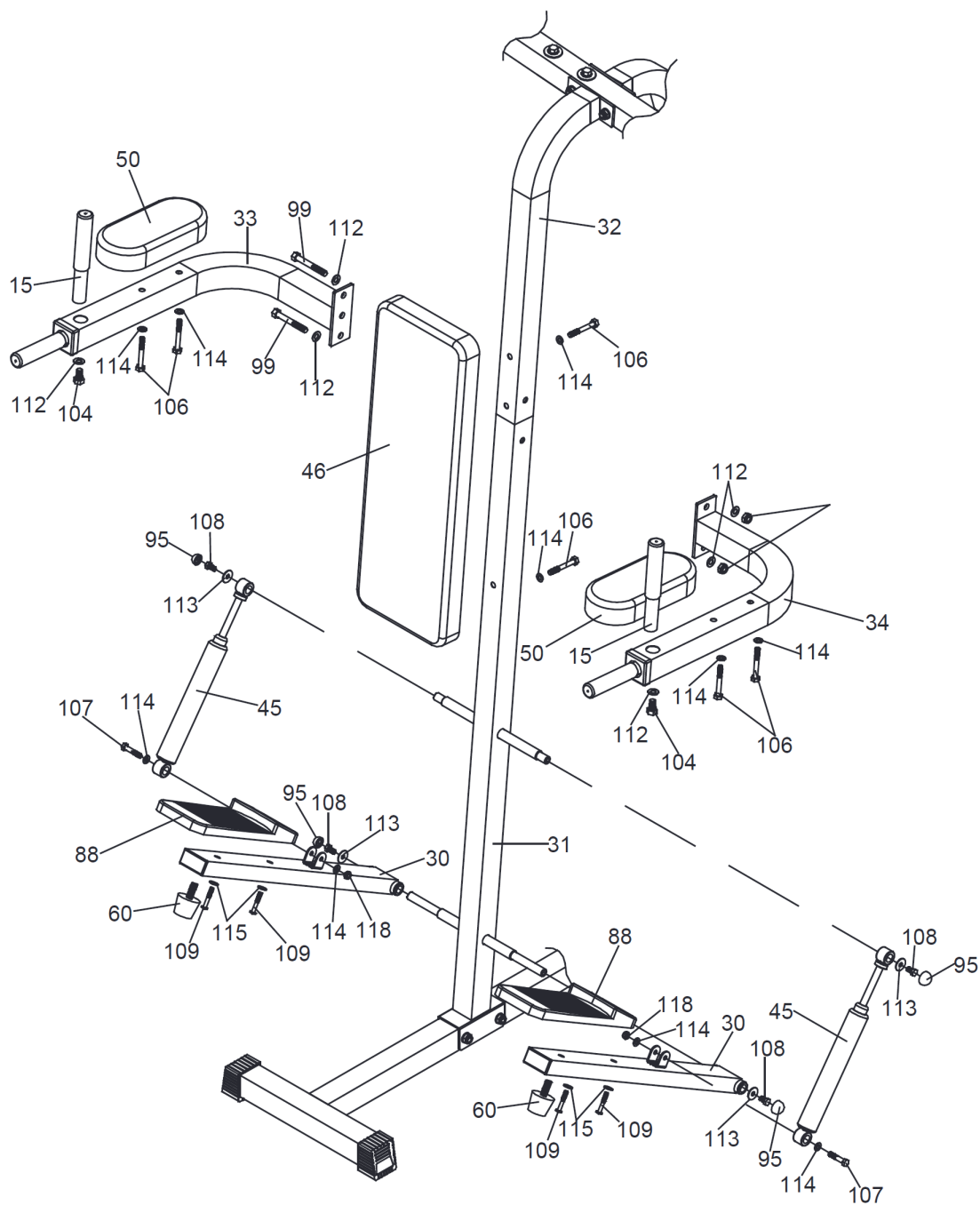

Befestigen Sie die Pedale (88) mit vier Schrauben (109) und vier Unterlegscheiben M6 (115) am Pedalrahmen (30). Befestigen Sie die zwei Stoßdämpfer (60) an den beiden Pedalrahmen (30). Befestigen Sie die beiden Pedalrahmen (30) mit zwei Sechskantschrauben (108), zwei Unterlegscheiben (113) und zwei Schraubkappen (95) am unteren Stützrahmen (31).

Befestigen Sie die beiden Zylinder (45) mit zwei Sechskantschrauben (108), zwei Unterlegscheiben (113) und zwei Schraubkappen (95) am unteren Stützrahmen (31). Befestigen Sie die beiden Zylinder (45) mit zwei Sechskantschrauben (107), vier Unterlegscheiben (114) und zwei Nylonmuttern (118) an den Pedalrahmen (30).

Befestigen Sie den rechten und linken Bogen (33&34) mit zwei Sechskantschrauben (99), vier Unterlegscheiben (112) und zwei Nylonmuttern M10 (117) am unteren (31) und oberen Stützrahmen (32). Befestigen Sie die Griffrohre (15) mit zwei Sechskantschrauben (104) und zwei Unterlegscheiben (112) am rechten und linken Bogen (33&34).

Befestigen Sie das Rückenlehnenpolster (46) mit zwei Sechskantschrauben (106) und zwei Unterlegscheiben (114) am unteren (31) und oberen Stützrahmen (32). Befestigen Sie die beiden Armkissen (50) mit vier Sechskantschrauben (106) und vier Unterlegscheiben (114) am rechten und linken Bogen (33&34).

# INSTALLATION DER KABEL

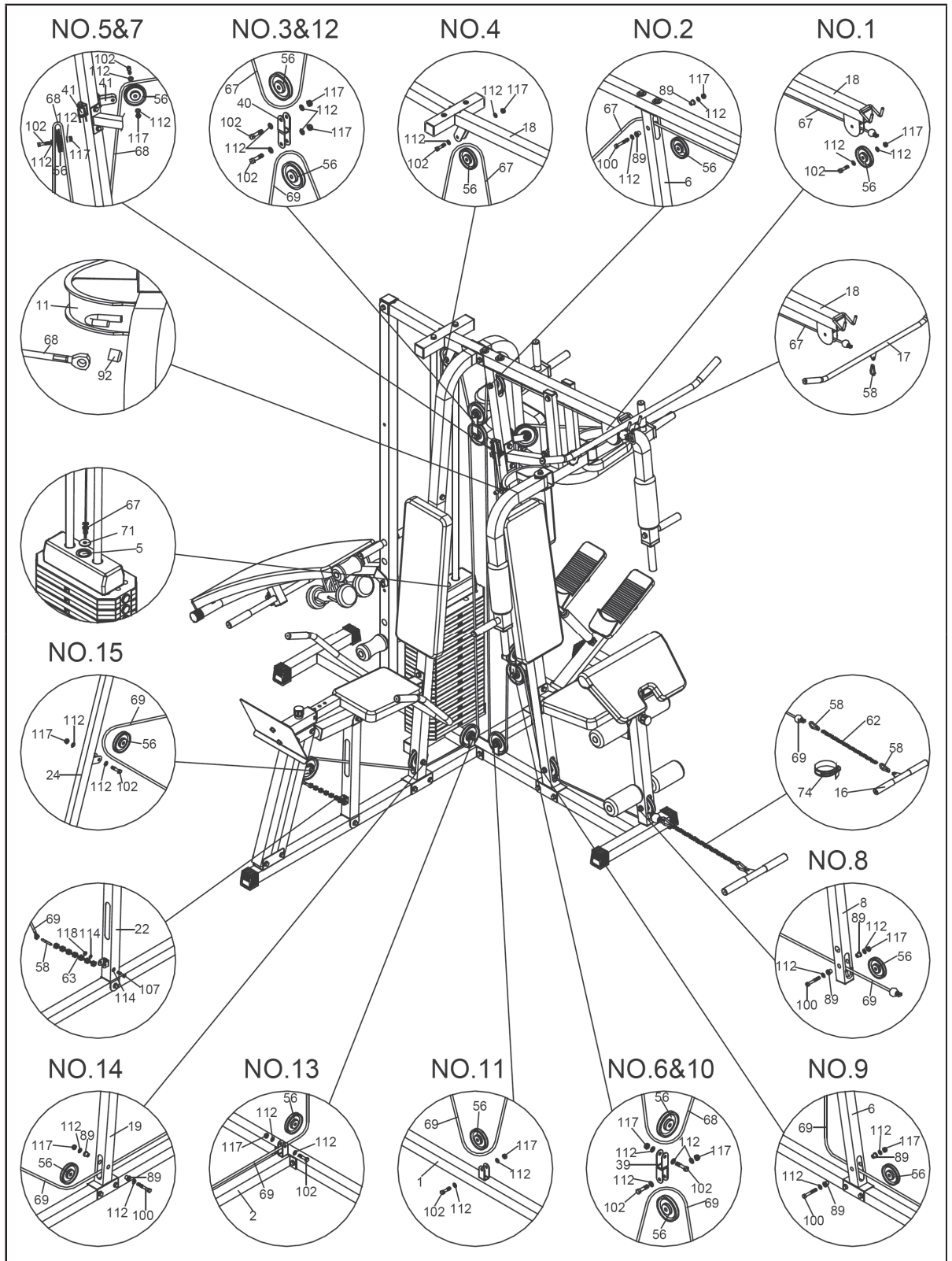



### Starten Sie mit dem oberen Kabel (76)

- (a) Führen Sie das obere Kabel (67), im der Nut der Riemenscheibe (56) liegend, durch den oberen Querbalken (18).
- (b) Montieren Sie die Riemenscheibe (56), wie auf Bild „NO.1“ dargestellt, mit einer Sechskantschraube M10x45 mm (102), zwei M10-Scheiben (112) und eine M10-Nylonmutter (117) am oberen Querbalken (18).
- (c) Montieren Sie die Riemenscheibe (56) und die beiden kleinen Buchsen, wie auf Bild „NO.2“ dargestellt mit einer M10x70 mm Sechskantschraube (100), zwei M10 Unterlegscheiben (112) und eine M10 Nylonmutter (117) am Stützrahmen (6).
- (d) Montieren Sie die Riemenscheibe (56), wie auf Bild „NO.3“ dargestellt, mit einer Sechskantschraube M10x45 mm (102), zwei M10-Scheiben (112) und eine M10-Nylonmutter (117) am oberen Querbalken (18).
- (e) Befestigen Sie das Bolzenende des oberen Kabels (67) mit einer Unterlegscheibe (71) an der Schaltwelle (5).
- (f) Montieren Sie die Riemenscheibe (56), wie auf Bild „NO.3“ dargestellt, mit einer Sechskantschraube M10x45 mm (102), zwei M10 Unterlegscheiben (112) und eine M10-Nylonmutter (117) am doppelten U-Stück (40).
- (g) Befestigen Sie die Latzugstange (17) mit dem Karabiner (58) am anderen Ende des oberen Kabels (67).

### 2. Montage des Butterfly-Kabels (68)

- (a) Befestigen Sie die beide Enden des Butterflykabels (68) mit zwei Schrauben am rechten und linken Butterflyarm (11&12) und befestigen Sie dann die Kunststoffabdeckungen (92).
- (b) Montieren Sie die Riemenscheibe (56), wie auf Bild „NO.5&7“ dargestellt, mit zwei Sechskantschrauben M10x45 mm (102), vier M10-Scheiben (112) und zwei M10-Nylonmutter (117) am einzelnen U-Stück (41).
- (c) Montieren Sie die Riemenscheibe (56), wie auf Bild „NO.6“ dargestellt, mit einer M10x45 mm Sechskantschraube (102), zwei M10 Unterlegscheiben (112) und eine M10-Nylonmutter (117) am doppelten U-Stück (39).

### 3. Montage des unteren Kabels (69)

- (a) Führen Sie das untere Kabel (69), im der Nut der Riemenscheibe (56) liegend, durch den Beinstrecker (8).
- (b) Montieren Sie die Riemenscheibe (56) und die zwei kleinen Buchsen (89), wie auf Bild „NO.8“ dargestellt, mit einer M10x70 mm Sechskantschraube (100), zwei M10 Unterlegscheiben (112) und einer M10 Nylonmutter (117) am Beinstrecker (8).
- (c) Montieren Sie die Riemenscheibe (56) und die zwei kleinen Buchsen (89), wie auf Bild „NO.9“ dargestellt, mit einer Sechskantschraube M10x70 mm (100), zwei Unterlegscheiben M10 (112) und einer Nylonmutter M10 (117) am Unterstützungsrahmen (6).
- (d) Montieren Sie die Riemenscheibe (56), wie auf Bild „NO.10“ dargestellt, mit einer M10x45 mm Sechskantschraube (102), zwei M10 Unterlegscheiben (112) und einer M10 Nylonmutter (117) an der Rückseite des doppelten U-Stücks (39).
- (e) Montieren Sie die Riemenscheibe (56), wie auf Bild „NO.11“ dargestellt mit einer Sechskantschraube M10x45 mm (102), zwei M10 Unterlegscheiben (112) und eine M10-Nylonmutter (117) am Grundrahmen (1).
- (f) Montieren Sie die Riemenscheibe (56), wie auf Bild „NO.12“ dargestellt, mit einer Sechskantschraube M10x45 mm (102), zwei M10 Unterlegscheiben (112) und eine M10-Nylonmutter (117) am doppelten U-Stück (40).
- (g) Montieren Sie die Riemenscheibe (56), wie auf Bild „NO.13“ dargestellt, mit einer Sechskantschraube M10x45 mm (102), zwei M10-Scheiben (112) und eine M10-Nylonmutter (117) am Grundrahmen der Beinpresse (2).
- (h) Montieren Sie die Riemenscheibe (56) und die zwei kleinen Buchsen (89), wie auf Bild „NO.14“ dargestellt, mit einer M10x70 mm Sechskantschraube (100), zwei M10 Unterlegscheiben (112) und einer M10 Nylonmutter (117) an der unteren Stütze der Beinpresse (19).
- (i) Montieren Sie die Riemenscheibe (56), wie auf Bild „NO.15“ dargestellt, mit einer M10x45 mm Sechskantschraube (102), zwei M10-Scheiben (112) und eine M10-Nylonmutter (117) am aufrechten Rahmen der Hinterbeinpresse (24).
- (j) Befestigen Sie das Schraubenende des unteren Kabels (69) mit einem Karabiner (58), einer kurzen Kette (63), ein Sechskantschraube M8x40 mm (107), zwei Unterlegscheiben M8 (114) und eine M8-Nylonmutter (118) Sitzträgerrahmen der Beinpresse (22).
- (k) Befestigen Sie das untere Rohr (16) und das Band (74) am anderen Ende des unteren Kabels (69) mit einem Lange Kette (62) und zwei Karabinerhaken (58).

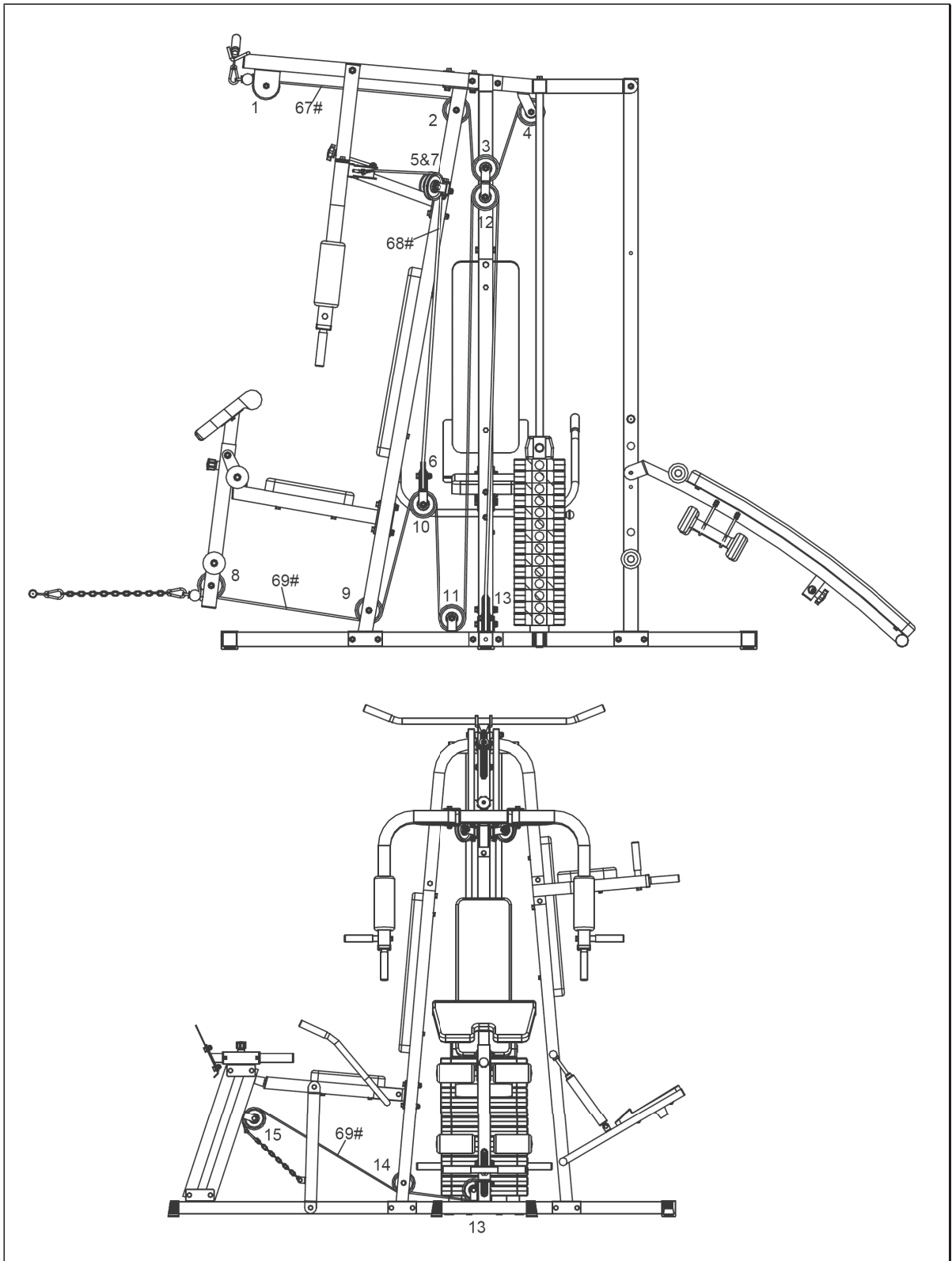

## AUFWÄRMUNG VOR DEM TRAINING

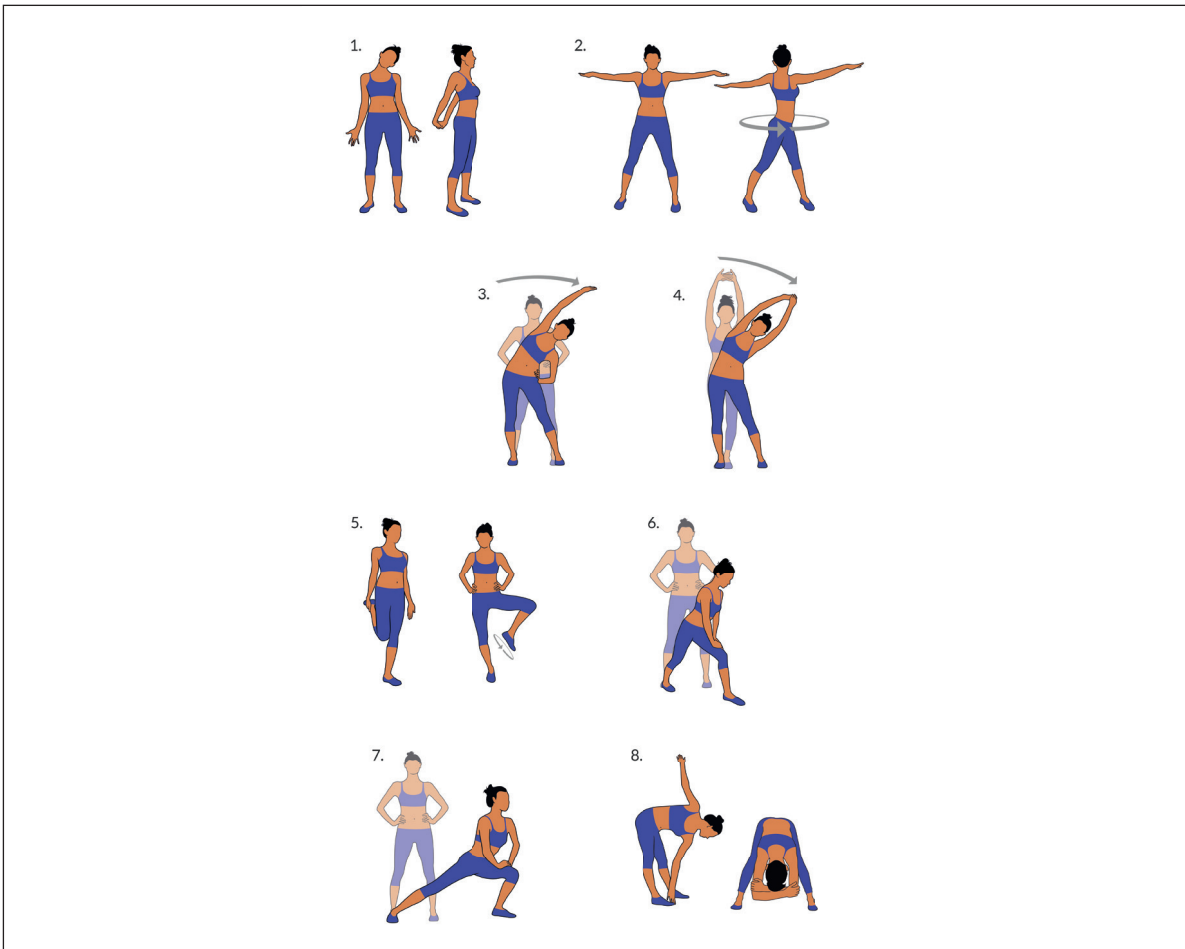

Führen Sie die Aufwärbewegungen vor jeder Trainingseinheit durch. So mobilisieren Sie Ihre Gelenke und aktivieren die Muskulatur.

Sollten Sie sich bei einzelnen Bewegungen unwohl fühlen oder Schmerz empfinden, so überspringen Sie diese Übung und stimmen sich über ein spezifisches Aufwärmtraining mit Ihrem Arzt bzw. Fitnesstrainer ab.

Jede Bewegung sollte einige Wiederholungen erfahren (rechts und links) sodass Sie entspannt ins Cardiotraining starten können.

### **Nehmen Sie sich für die folgende Klarfit-Trainingsroutine etwa 5 Minuten Zeit:**

1. Kopf seitlich neigen, langsam abwechselnd von rechts nach links. Im Anschluss mobilisieren Sie die Schultern (Kreisbewegungen und Schulterzucken).
2. Hüfte drehen während die Arme gestreckt sind. Die Füße sind dabei nicht fest am Boden fixiert (die Fußgelenke begleiten die Körperdrehung).
3. Hüfte beugen, ein Arm gestreckt nach oben. Verbleiben Sie in dieser Position jeweils einige Sekunden pro Seite.
4. Hüfte beugen, beide Arme oben geschlossen. Auch hier verbleiben Sie auf jeder Seite, die Übung ist nun etwas intensiver, da der zweite Arm mitzieht.
5. Stellen sie sich auf ein Bein und halten den Spann mit der Hand. Hier mobilisieren Sie ihr Fußgelenk und strecken den Oberschenkel leicht. Stützen Sie sich gegebenenfalls ab, um Ihr Gleichgewicht zu halten. Verbleiben Sie auf einem Bein und drehen das Fußgelenk nun kreisförmig in beide Richtungen.
6. Stellen Sie ein Bein nach vorne und stützen sich mit dem Oberkörper auf dem Oberschenkel ab. Hierbei mobilisieren Sie neben den Knie- und Fußgelenken auch die hintere Wadenmuskulatur.
7. Wiederholen Sie die Übung aus Punkt 6. mit dem Unterschied, dass Sie nun einen großen Ausfallschritt nach vorne machen. Die Bewegung wird jetzt intensiver.
8. Beugen Sie sich mit gestreckten Beinen nach vorne und berühren Sie abwechselnd mit der Hand den gegenüberliegenden Fuß. Zum Schluss lassen Sie sich entspannt und locker nach unten hängen.



**Dear Customer,**

Congratulations on purchasing this equipment. Please read this manual carefully and take care of the following hints to avoid damages. Any failure caused by ignoring the items and cautions mentioned in the instruction manual is not covered by our warranty and any liability. Scan the QR code to get access to the latest user manual and other information about the product.

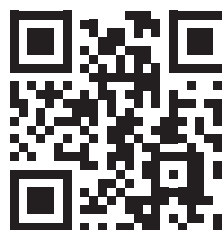

---

**CONTENT**

---

Safety Instructions 30  
Parts Overview 31  
Assembly 35  
Installing the Cables 46  
Warming up before a Workout 49

---

**MANUFACTURER & IMPORTER (UK)**

---

**Manufacturer:**

Chal-Tec GmbH, Wallstrasse 16, 10179 Berlin, Germany.

**Importer for Great Britain:**

Berlin Brands Group UK Limited  
PO Box 42  
272 Kensington High Street  
London, W8 6ND  
United Kingdom

---

**CARE AND MAINTENANCE**

---

**Note:** As with all training equipment with mechanical, moving components, screws may loosen as a result of frequent use of this product. We therefore recommend that you check them regularly and, if necessary, tighten them with a suitable key. Clean your training device regularly with a damp cloth to clean the surfaces of sweat and dust.

- Clean the device regularly with a clean cloth to maintain a clean appearance.
- Safe use of the device can only be guaranteed if the device is regularly checked for damage and wear (e.g. to handles, pedals, saddles, etc.). It is essential that damaged parts are replaced and that the unit is not reused until it has been repaired.
- Check regularly that bolts and nuts are properly tightened.
- Grease moving parts of the unit regularly.











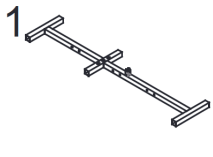
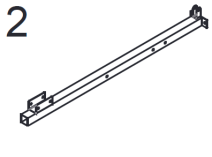
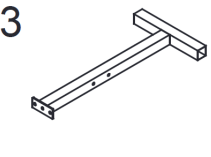



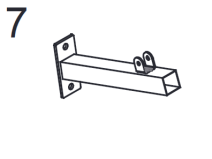
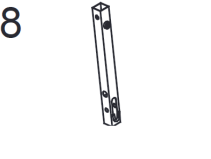
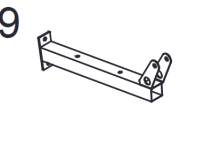
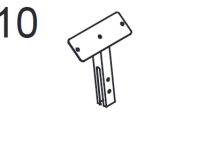
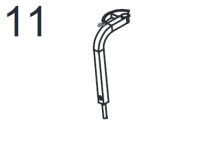
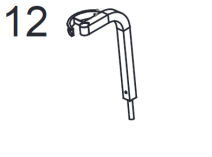
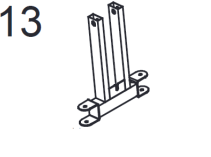

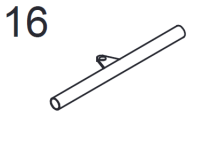
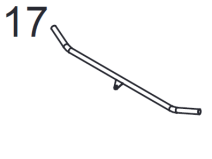
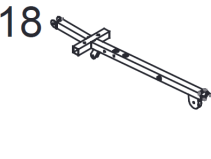

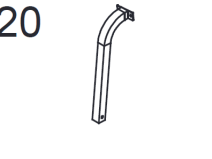
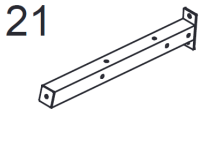
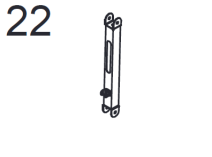
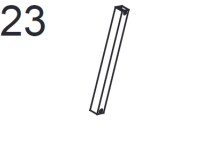

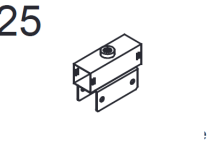
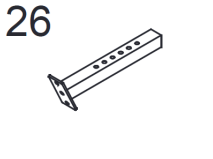

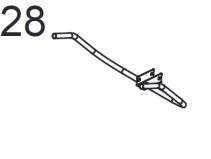

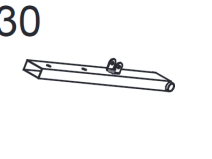
## SAFETY INSTRUCTIONS

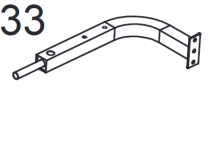
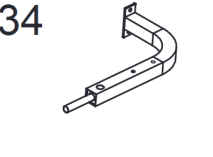
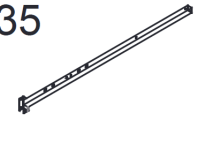
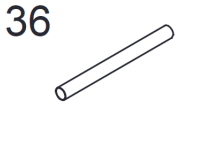
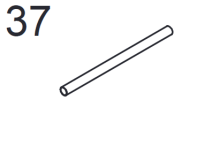
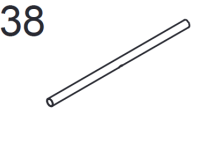

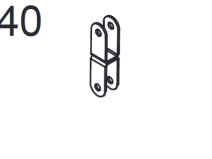

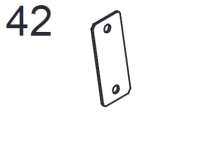

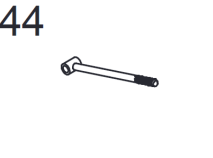











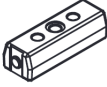

























Before operating this unit, please read this manual carefully to ensure optimum performance and safety. This manual should be kept available for future reference. For product improvement, the company reserves the right to change the design and specification at any time without prior notice. Pictures are for reference use only and may differ from the actual product.

- Please keep this manual in a safe place for your reference when necessary.
- Please do not assemble or use this equipment until you read this manual thoroughly & carefully. The safety and efficiency only can be achieved when the equipment is assembled, maintained and used properly. It is your responsibility to ensure that all the users are informed of all the warnings and precautions.
- For totally safe use, a stable, leveled surface is required. Protect your floor with a mat. Do not use the equipment in a damp areas such as swimming pool sauna, etc. For safety space, the equipment must have at least 0.6 meter of free space all around it.
- Before starting any exercise program you must consult your doctor to determine if you have any physical or health conditions that could create a risk to your health and safety, or prevent you from using the equipment properly. Your doctor's advice is essential if you are taking medication that affects your heart rate, blood pressure or cholesterol level.
- Be aware of your body's signals. Incorrect or excessive exercise can damage your health. Stop exercising if you experienced any of the following symptoms: pain, tightness in your chest, irregular heartbeat, extreme shortness of breath, feeling light headed, dizzy or nauseous. If you do experience any of these conditions you must consult your doctor before continuing with your exercise program.
- Do not workout immediately after meals.
- Keep children and pets away from the equipment, the equipment must be assembled and used by adults only.
- The equipment is designed for home use only.
- The equipment is not suitable for therapeutic use, may only be used for exercises indicated in the training instructions
- Wearing proper clothing and athletic shoes while using the equipment, Avoid wearing loose clothing that may get caught in the equipment or that may restrict or prevent movements.
- Keep your back straight while exercising.
- Before using the equipment, check the handle bar, seat, and the nuts & bolts are securely tightened.
- For adjustable parts, bear the maximum position in your mind, do not exceed the mark „stop“, otherwise will cause risk.
- Always use the equipment as indicated. If you find any defective components while assembling or checking the equipment, or if you hear any unusual noises coming from the equipment during use, stop immediately. Do not use the equipment until the problem has been solved.
- Care must be taken when lifting or moving the equipment so as not to injure your back. always use proper lifting techniques and /or seek assistance if necessary.
- All moveable accessories(e.g. pedal, handlebar, saddle...etc.) require weekly maintenance. Check them before use every time. If anything broken or loose, please fix them immediately. You may continue using them only after they return to good conditions.
- Pay attention to the absence of a free wheel system which will cause serious risk.
- Keep power cord away from heat sources.
- Do not insert or drop any object into any opening.
- Unplug exercise bike before moving or cleaning it. To clean, wipe surfaces down with mild detergents and a slightly damp cloth only; never use solvents.
- Do not use the exercise bike in any location that is not temperature controlled, such as, but not limited to, garages, porches, pool rooms, bathrooms, car ports or outdoors.
- Use the bike only as described in this manual.
- Incorrect repair and structural modifications(e.g. removal or replacement of original parts) may endanger the safety of the user.
- The rotating disk flywheel will get hot during the operation.
- Lock the equipment when stop using.
- This product is not designed for use by persons (including children) who have reduced physical, sensory or mental capacities or persons with no experience or knowledge, unless they are instructed and supervised in the use of the appliance by a person responsible for their safety.
- Children should be supervised to ensure that they do not play with the appliance.
- Before use, check the voltage on the rating plate. Only connect the device to sockets that correspond to the voltage of the device.

**Note:** Maximum weight of the user is 120 kg.

**PARTS OVERVIEW**





























1 	2 	3 	4 	5 
6 	7 	8 	9 	10 
11 	12 	13 	14 	15 
16 	17 	18 	19 	20 
21 	22 	23 	24 	25 
26 	27 	28 	29 	30 
31 	32 	33 	34 	35 
36 	37 	38 	39 	40 
41 	42 	43 	44 	45 

46 	47 	48 	49 	50 
51 	52 	53 	54 	55 
56 	57 	58 	59 	60 
61 	62 	63 	64 	65 
66 	67 	68 	69 	70 
71 	72 	73 	74 	75 
76 	77 	78 	79 	80 
81 	82 	83 	84 	85 
86 	87 	88 	89 	90 



No.	Description	Pc.	No.	Description	Pc.
1	Base Frame	1	46	Backrest Cushion	3
2	Leg Press Base Frame	1	47	Seat Cushion	2
3	VKR Base Frame	1	48	Arm Cushion	1
4	Weight Guide Tube	4	49	Bench Cushion	1
5	Selector Shaft	1	50	Arm Cushion	2
6	Support Frame	1	51	Leg Extension Foam	4
7	Resist Bar	1	52	Arm Foam Roller	2
8	Leg Extension Frame	1	53	Bench Foam	4
9	Seat Frame	1	54	Top Weight Plate	1
10	Arm Frame	1	55	Weight Plate	14
11	Right Butterfly Arm	1	56	Pulley	15
12	Left Butterfly Arm	1	57	Weight Selector Pin	1
13	Press Bar	1	58	Pothook	4
14	Long Foam Tube	2	59	Bumper (long)	1
15	Handle Tube	4	60	Bumper (short)	2
16	Low Bar	1	61	Plum Blossom Nut	1
17	Lat Bar	1	62	Long Chain	1
18	Upper Cross Beam	1	63	Short Chain	1
19	Leg Press Lower Support	1	64	Knob	1
20	Leg Press Upper Support Frame	1	65	Oil Bushing	2
21	Leg Press Seat Frame	1	66	Safety Pin	1
22	Leg Press Seat Support Frame	1	67	Upper Cable	1
23	Front Leg Press Upright Frame	1	68	Butterfly Cable	1
24	Rear Leg Press Upright Frame	1	69	Lower Cable	1
25	Leg Press Connect Frame	1	70	Quick Knob	2
26	Leg Press Plate Adjust Frame	1	71	Plastic Washer	1
27	Leg Press Plate	1	72	Selector Shaft Bushing	1
28	Leg Press Hand Bar	1	73	Selector Shaft Pin	1
29	Bench Frame	1	74	Ankle Strap	1
30	Pedal Frame	2	75	Dumbbell	2
31	Lower Support Frame	1	76	Rubber Cushion	2
32	Upper Support Frame	1	77	Handle Grip	18
33	Right	1	78	50 mm Square End Cap	7
34	Left	1	79	Select Shaft End Cap	1
35	Rear Upright Frame	1	80	Mid-empty Square Plug	4
36	Bench Handle Tube	1	81	50 mm Square End Plug	8
37	Short Foam Tube	1	82	38 mm Square End Plug	2
38	Long Handle Tube	1	83	30x60 mm Square End Plug	2
39	Reverse U	1	84	25x50 mm Square End Plug	2
40	Pulley U	1	85	Pedal Bushing (big)	4
41	Single Pulley Block	2	86	25 mm Round End Plug	8
42	Plate	1	87	Mid-empty Square Plug	2
43	Dumbbell Hook	4	88	Pedal	2
44	Tobacco-pipe	1	89	Pulley Bushing (small)	8
45	Cylinder	2	90	Plastic Bushing	4

Hardware

91 	92 	93 	94 	95 
96 	97 	98 	99 	100 
101 	102 	103 	104 	105 
106 	107 	108 	109 	110 
111 	112 	113 	114 	115 
116 	117 	118 		

No.	Description	Pc.	No.	Description	Pc.
91	38 mm Round End Cap	2	105	M10x20 mm Bolt	4
92	Plastic Cover	2	106	M8x65 mm Hex Bolt	16
93	38 mm Square Cap	1	107	M8x40 mm Hex Bolt	4
94	Buffer Cap	2	108	M8x16mm Hex Bolt	10
95	Bolt Cap	4	109	M6x40 mm Bolt	4
96	M12x150 mm Hex Bolt	1	110	M12 Washer	4
97	M12x75 mm Hex Bolt	1	111	Ø30xØ10 Washer	1
98	M10x85 mm Hex Bolt	2	112	M10 Washer	111
99	M10 x 75 mm Hex Bolt	6	113	Ø25xØ8 Washer	4
100	M10x70 mm Hex Bolt	29	114	M8 Washer	32
101	M10x65 mm Hex Bolt	2	115	M6 Washer	4
102	M10x45 mm Hex Bolt	11	116	M12 Nylon Nut	2
103	M10x25 mm Hex Bolt	2	117	M10 Nylon Nut	52
104	M10x20 mm Hex Bolt	7	118	M8 Nylon Nut	6

## ASSEMBLY

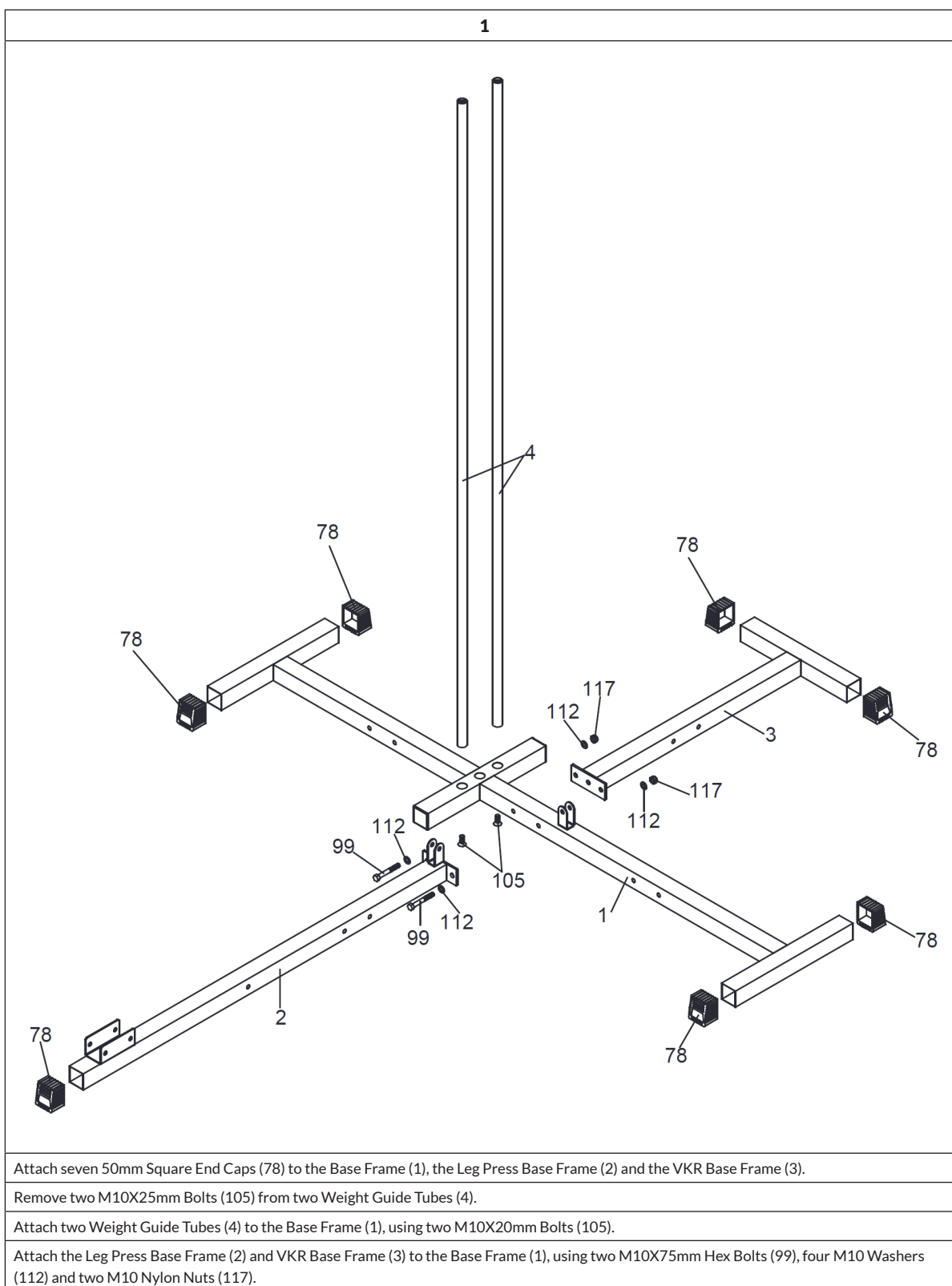

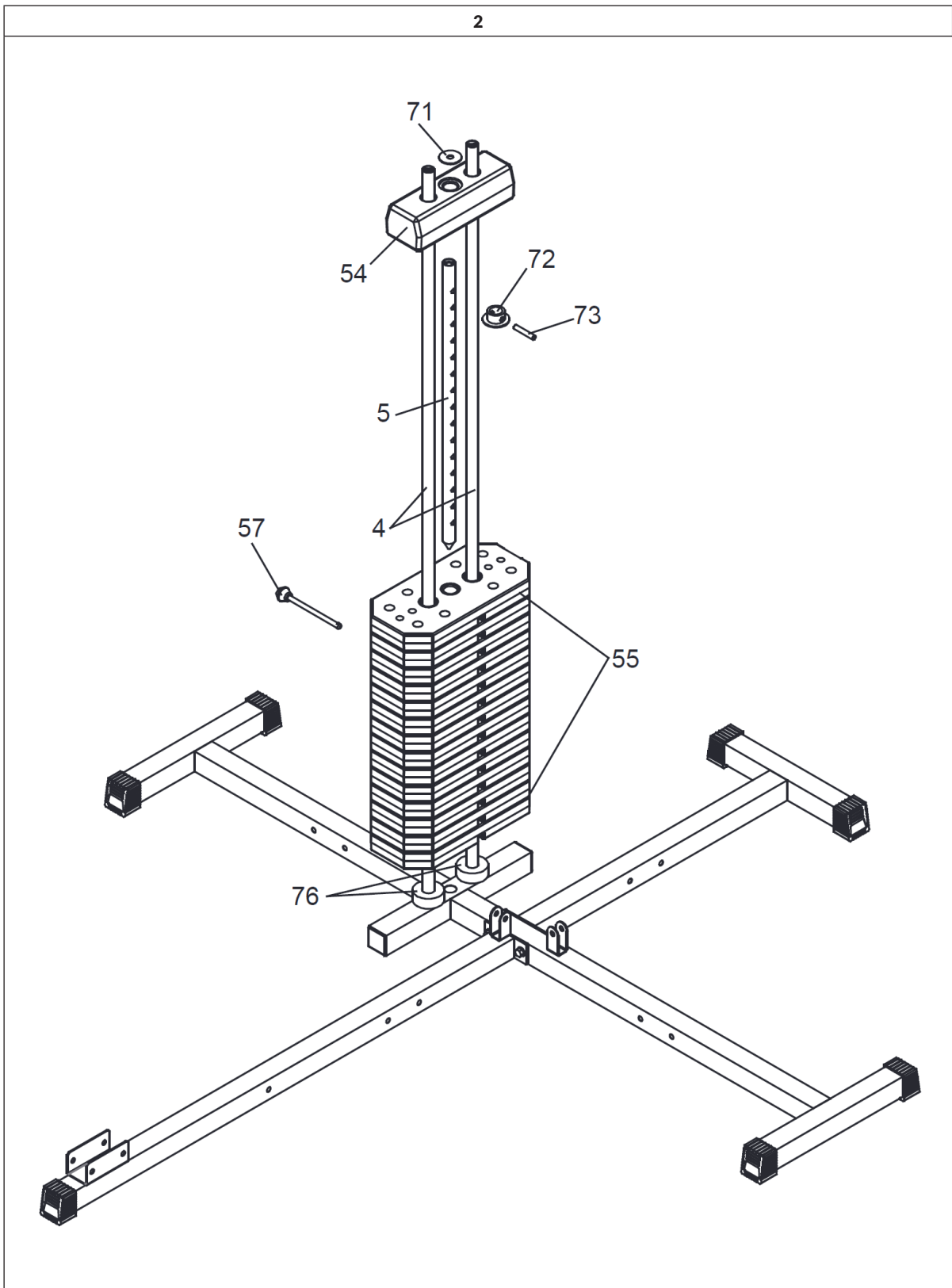

2

- Slide two Rubber Cushions (76) down the Weight Guide Tube (4).
- Slide fourteen Weight Plates (55) down the Weight Guide Tube (4).
- Slide the Selector Shaft Bushing (72) down the Selector Shaft (5) at first hole fix with the Selector Shaft Pin (73).
- Insert the Selector Shaft (5) into hole of the Weight Plate (55).
- Slide the Top Weight Plate (54) down the Weight Guide Tube (4), insert the Weight Selector Pin (57) into hole of desire weight.
- Put the Plastic Washer (71) on the Top Weight Plate (54).

3

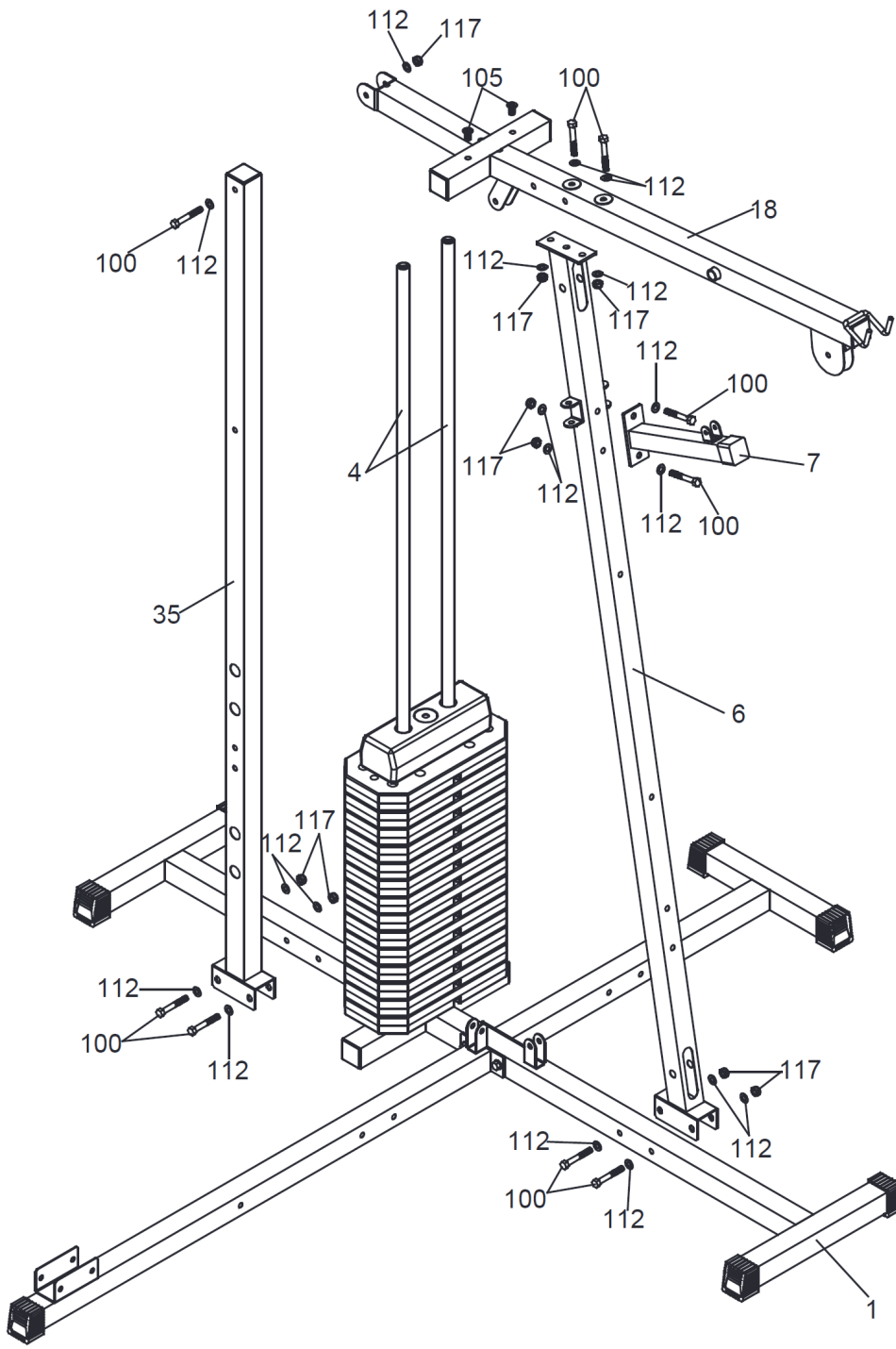

Attach the Support Frame (6) and Rear Upright Frame (35) to the Base Frame (1), using four M10X70mm Hex Bolts (100), eight M10 Washers (112) and four M10 Nylon Nuts (117).

Remove two M10X25mm Bolts (105) from two Weight Guide Tubes (4).

Attach the Upper Cross Beam (18) to the two Weight Guide Tubes (4), using two M10X25mm Bolts (105).

Attach the Upper Cross Beam (18) to the Support Frame (6) and Rear Upright Frame (35), using three M10X70mm Hex Bolts (100), six M10 Washers (112) and three M10 Nylon Nuts (117).

Attach the Resist Bar (7) to the Support Frame (6), using two M10X70mm Hex Bolts (100), four M10 Washers (112) and two M10 Nylon Nuts (117).

4

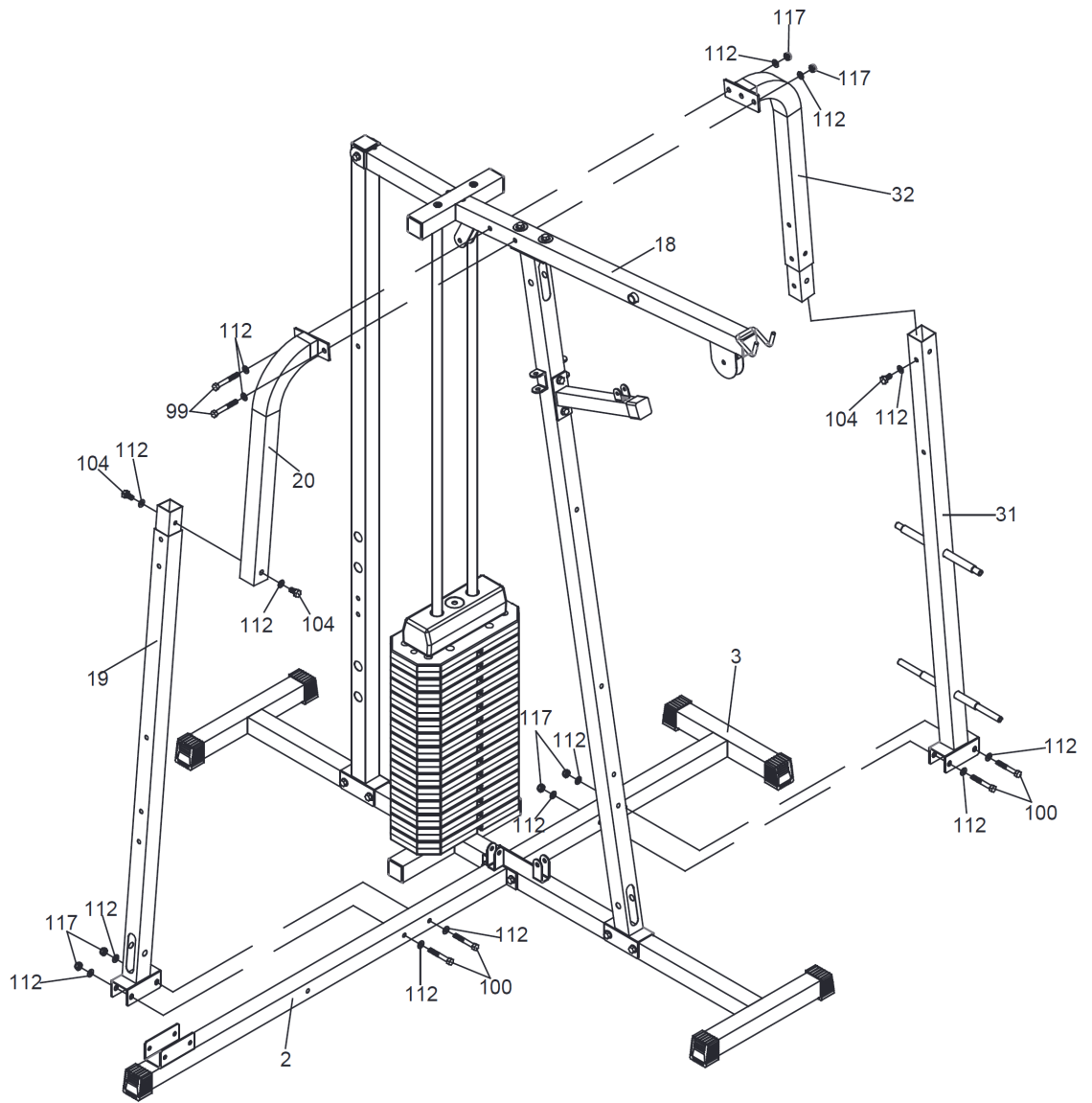

Attach the Leg Press Lower Support Frame (19) to the Leg Press Base Frame (2), using two M10X70mm Hex Bolts (100), four M10 Washers (112) and two M10 Nylon Nuts (117).

Attach the VKR Lower Support Frame (31) to the VKR Base Frame (3), using two M10X70mm Hex Bolts (100), four M10 Washers (112) and two M10 Nylon Nuts (117).

Attach the Leg Press Upper Support Frame (20) to the Leg Press Lower Support Frame (19), using two M10X20mm Hex Bolts (104) and two M10 Washers (112).

Attach the VKR Upper Support Frame (32) to the VKR Lower Support Frame (31), using one M10X20mm Hex Bolts (104) and one M10 Washers (112).

Attach the Leg Press Upper Support Frame (20) and VKR Upper Support Frame (32) to the Upper Cross Beam (18), using two M10X75mm Hex Bolts (99), four M10 Washers (112) and two M10 Nylon Nuts (117).

5

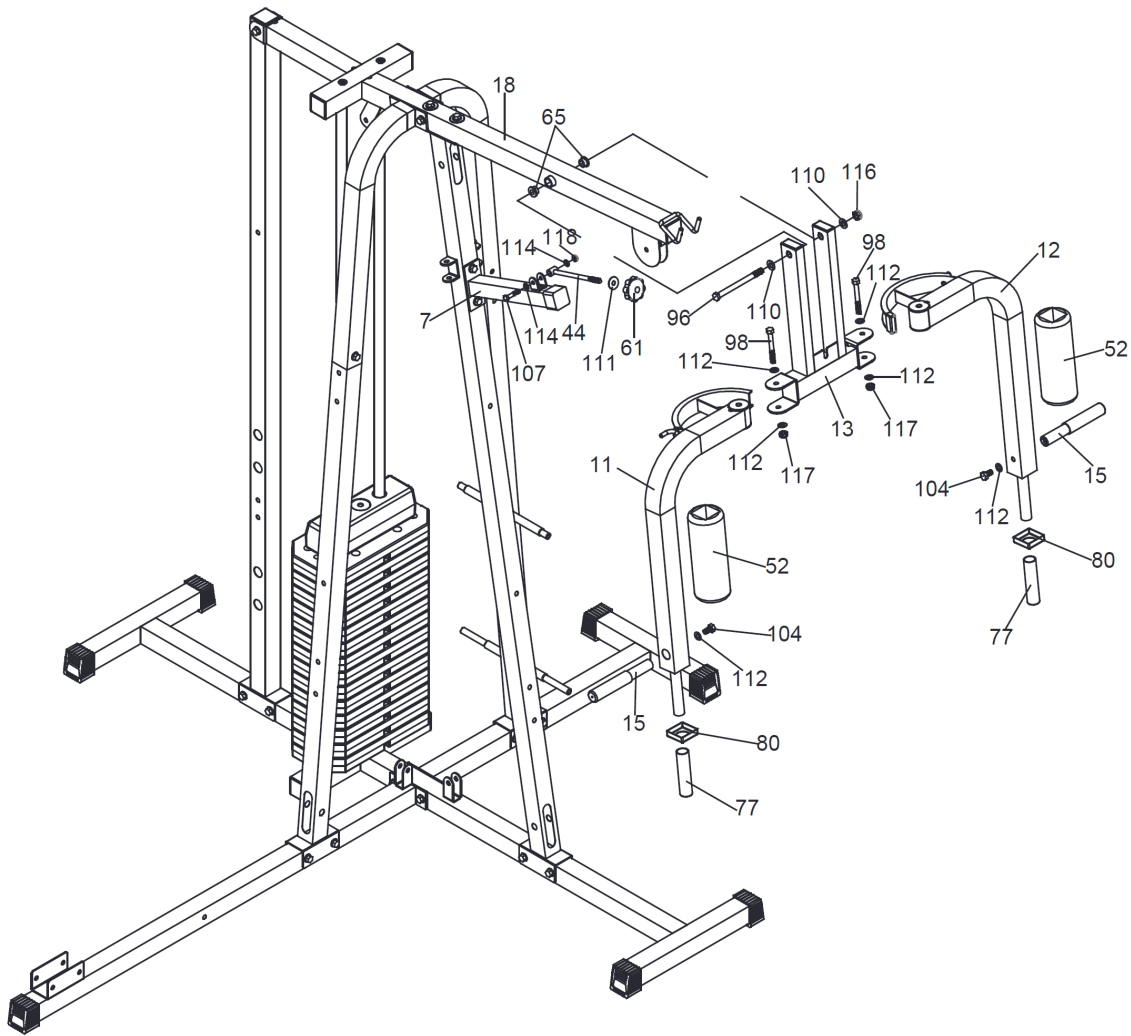

**Note:** Oil Bushing (65) have been Pre-assembled into Upper Cross Beam (18).

Attach the Press Bar (13) to the Upper Cross Beam (18), using one M12X150mm Hex Bolt (96), two M12 Washers (110) and one M12 Nylon Nuts (116).

Attach the Left & Right Butterfly Arm (11&12) to the Press Bar (13), using two M10X85mm Hex Bolts (98), four M10 Washers (112) and two M10 Nylon Nuts (117).

Slide two Arm Foam Rollers (52) onto the Left & Right Butterfly Arm (11&12).

Remove two M10X20mm Hex Bolts (104) and two M10 Washers (112) from two Handle Tubes (15).

Attach two Handle Tubes (15) to the Left & Right Butterfly Arm (11&12), using two M10X20mm Hex Bolts (104) and two M10 Washers (112).

Slide two Mid-empty Square Plugs (80) and two Handle Grips (77) onto the Left & Right Butterfly Arm (11&12).

Attach the Tobacco-pipe (44) to the Resist Bar (7), using one M8X40mm Hex Bolt (107), two M8 Washers (114) and one M8 Nylon Nut (118).

Slide the Washer (111) and the Plum Blossom Nut (61) onto the Tobacco-pipe (44).

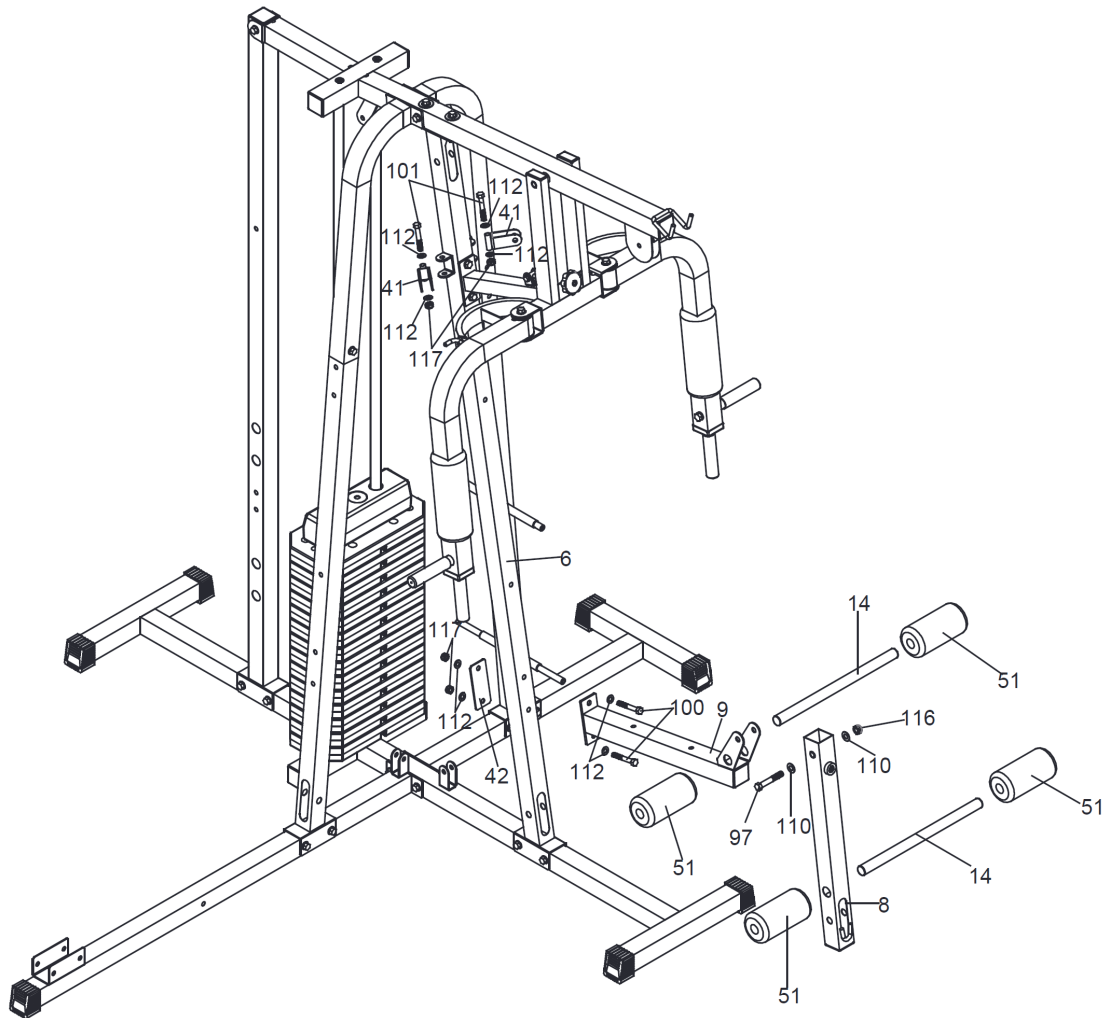

- Attach the Seat Frame (9) and Plate (42) to the Support Frame (6), using two M10X70mm Hex Bolts (100), four M10 Washers (112) and two M10 Nylon Nuts (117).
- Attach the Leg Extension Frame (8) to the Seat Frame (9), using one M12X75mm Hex Bolt (97), two M12 Washers (110) and one M12 Nylon Nuts (116).
- Insert two Long Foam Tubes (14) into the Leg Extension Frame (8) and the Seat Frame (9).
- Slide four Leg Extension Foams (51) onto the Long Foam Tube (14).
- Attach the two Single Pulley Blocks (41) to the Support Frame (6), using two M10X65mm Hex Bolts (101), four M10 Washers (112) and two M10 Nylon Nuts (117).



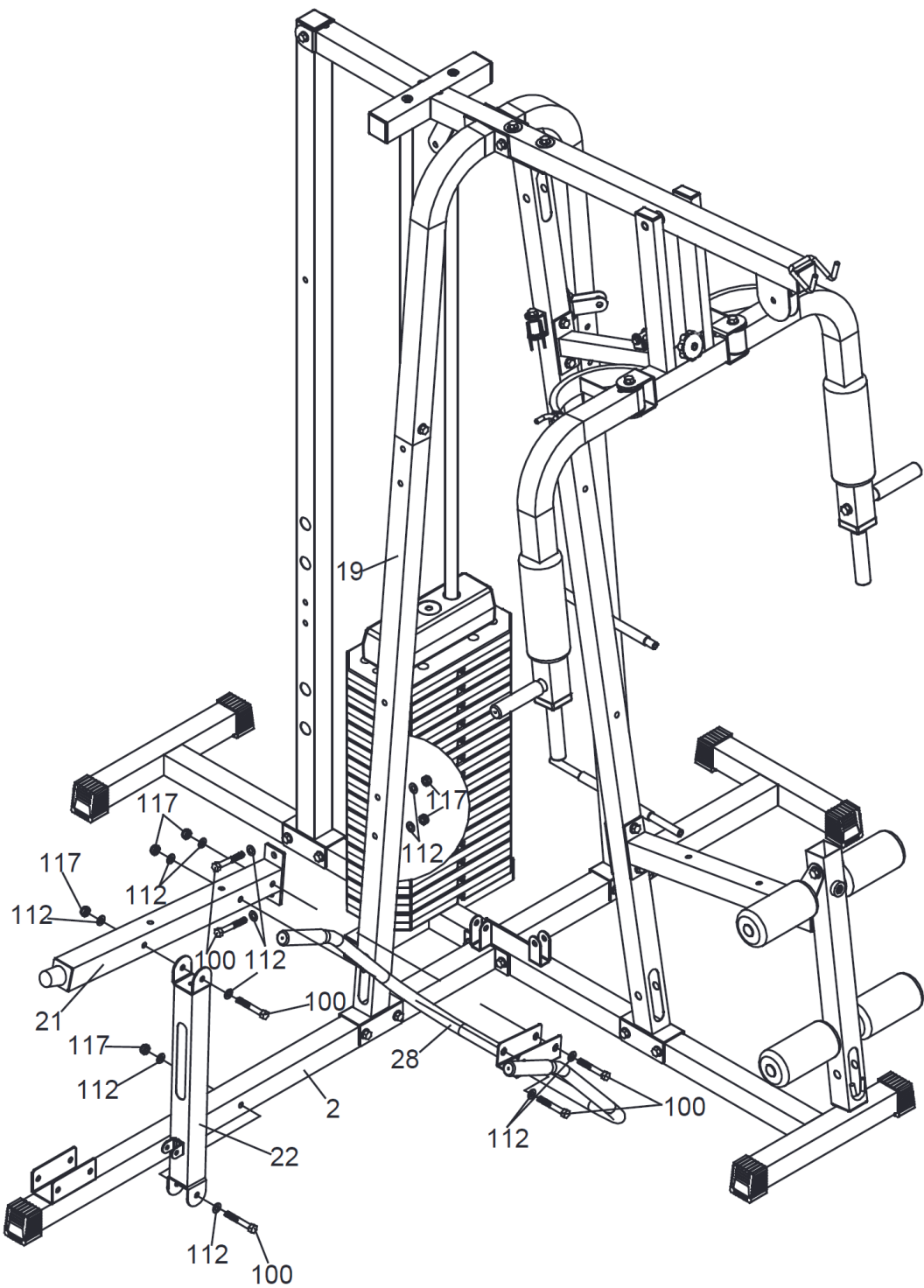

Attach the Leg Press Seat Support Frame (22) to the Leg Press Base Frame (2), using one M10X70mm Hex Bolts (100), two M10 Washers (112) and one M10 Nylon Nut (117).

Attach the Leg Press Seat Frame (21) to the Leg Press Lower Support Frame (19) and Leg Press Seat Support Frame (22), using three M10X70mm Hex Bolts (100), six M10 Washers (112) and three M10 Nylon Nuts (117).

Attach the Leg Press Hand Bar (28) to the Leg Press Seat Frame (21), using two M10X70mm Hex Bolts (100), four M10 Washers (112) and two M10 Nylon Nuts (117).

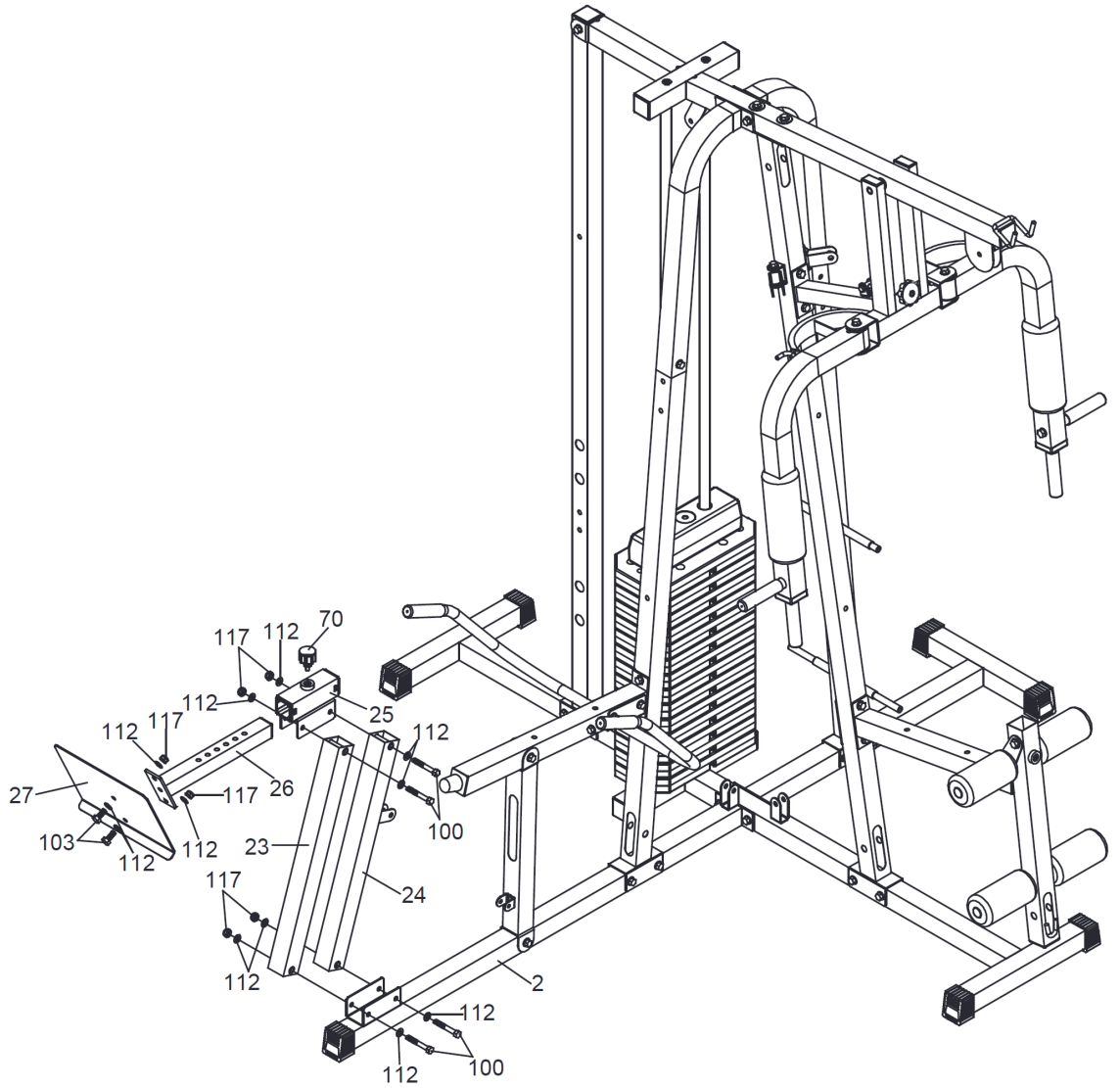

Attach the Front Leg Press Upright Frame (23) and Rear Leg Press Upright Frame (24) to the Leg Press Base Frame (2), using two M10X70mm Hex Bolts (100), four M10 Washers (112) and two M10 Nylon Nuts (117).

Attach the Leg Press Connect Frame (25) to the Front Leg Press Upright Frame (23) and Rear Leg Press Upright Frame (24), using two M10X70mm Hex Bolts (100), four M10 Washers (112) and two M10 Nylon Nuts (117).

Attach the Leg Press Plate (27) to the Leg Press Plate Adjust Frame (26), using two M10X25mm Hex Bolts (103), four M10 Washers (112) and two M10 Nylon Nuts (117).

Insert Leg Press Plate Adjust Frame (26) into the Leg Press Connect Frame (25), using one Quick Knob (70).

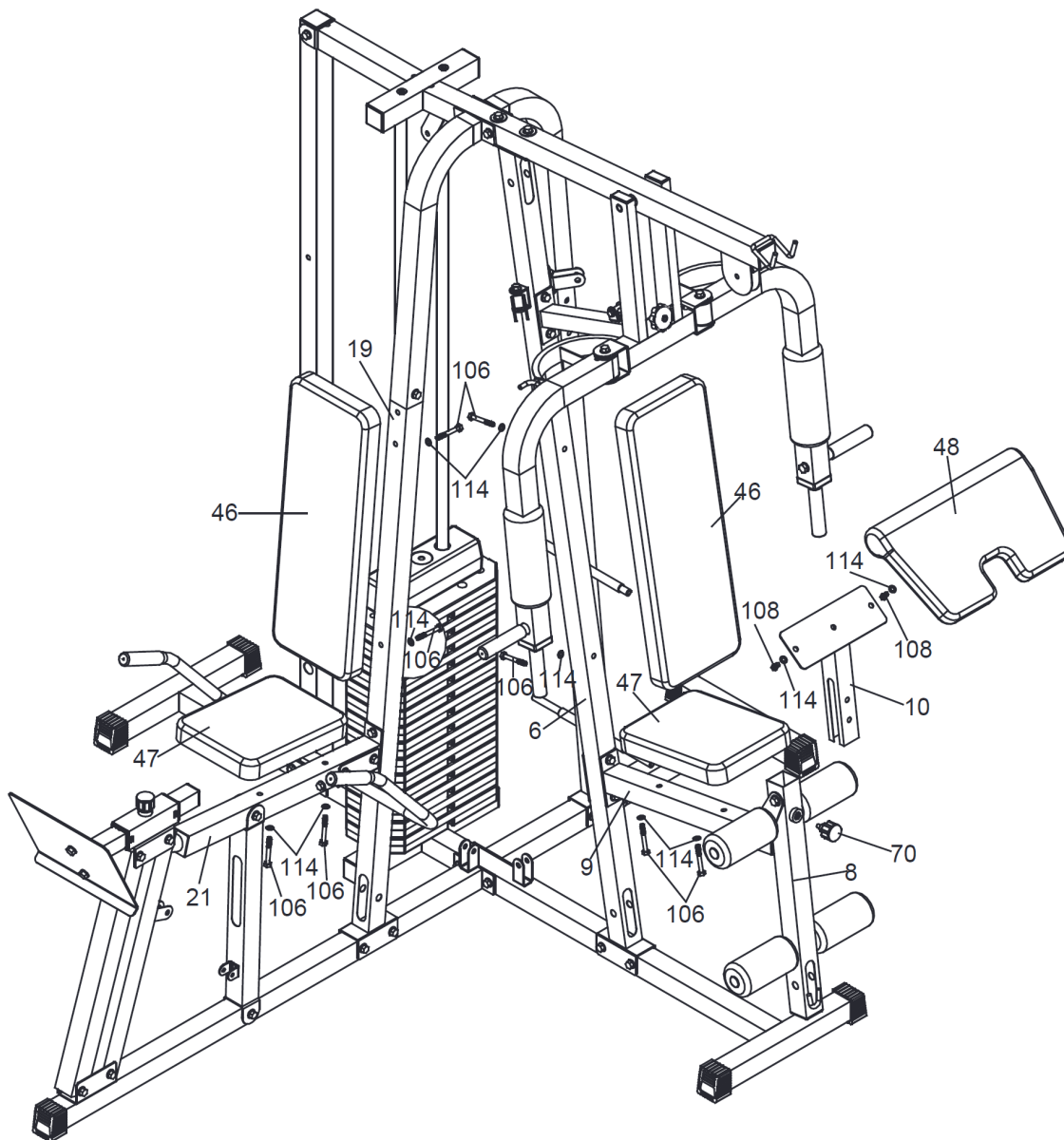

Attach the two Backrest Cushions (46) to the Support Frame (6) and Leg Press Lower Support Frame (19), using four M8X65mm Hex Bolts (106) and four M8 Washers (114).

Attach the two Seat Cushions (47) to the Seat Frame (9) and Leg Press Seat Frame (21), using four M8X65mm Hex Bolts (106) and four M8 Washers (114).

Attach the Arm Cushion (48) to the Arm Frame (10), using two M8X16mm Hex Bolts (108) and two M8 Washers (114).

Insert Arm Frame (10) into the Leg Extension Frame (8), using one Quick Knob (70).

10

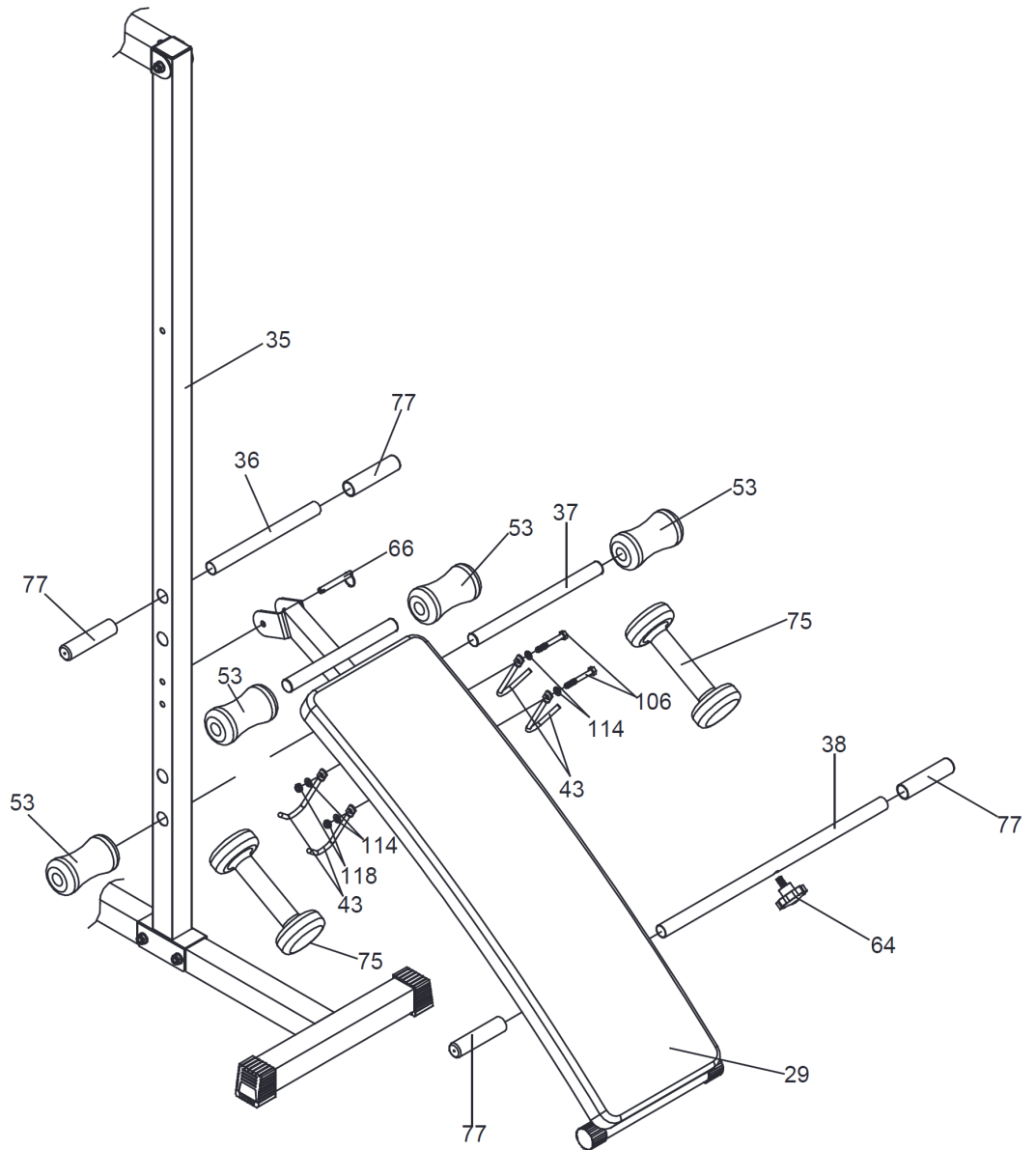

Attach the four Dumbbell Hooks (43) to the Bench Frame (29), using two M8X65mm Hex Bolts (106), four M8 Washers (114) and two M8 Nylon Nuts (118). In the two Dumbbells (75).

Insert Long Handle Tube (38) into the Bench Frame (29), using one Knob (64). Slide two Handle Grips (77) onto the Long Handle Tube (38).

Attach the Bench Frame (29) to the Rear Upright Frame (35), using one Quick (66).

Insert Bench Handle Tube (36) into the Rear Upright Frame (35). Slide two Handle Grips (77) onto the Bench Handle Tube (36).

Insert Short Foam Tube (37) into the Bench Frame (29). Slide four Bench Foams (53) onto the Short Foam Tube (37) and Bench Frame (29).

11

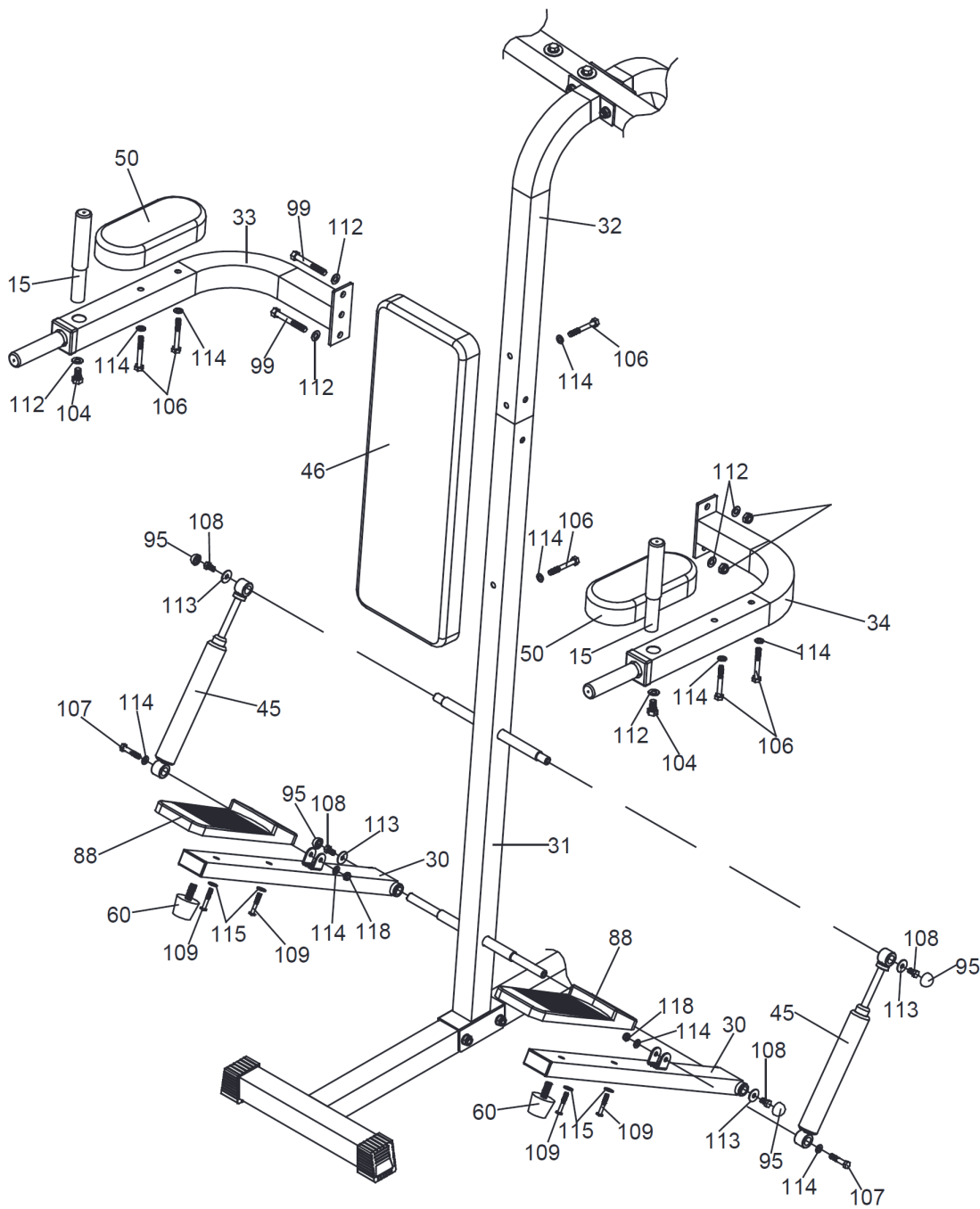

Attach the two Pedals (88) to the two Pedal Frames (30), using four M6X40mm Bolts (109) and four M6 Washers (115). Attach two Bumper (short) (60) to the two Pedal Frames (30). Attach the two Pedal Frames (30) to the VKR Lower Support Frame (31), using two M8X16mm Hex Bolts (108), two Washers (113) and two Bolt Caps (95).

Attach the two Cylinders (45) to the VKR Lower Support Frame (31), using two M8X16mm Hex Bolts (108), two Washers (113) and two Bolt Caps (95). 4. Attach the two Cylinders (45) to the two Pedal Frames (30), using two M8X40mm Hex Bolts (107), four M8 Washers (114) and two M8 Nylon Nuts (118).

Attach the Right & Left VKR (33&34) to the VKR Lower Support Frame (31) and VKR Upper Support Frame (32), using two M10X75mm Hex Bolts (99), four M10 Washers (112) and two M10 Nylon Nuts (117).

Attach the two Handle Tubes (15) to the Right & Left VKR (33&34), using two M10X20mm Hex Bolts (104) and two M10 Washers (112). Attach the Backrest Cushion (46) to the VKR Lower Support Frame (31) and VKR Upper Support Frame (32), using two M8X65mm Hex Bolts (106) and two M8 Washers (114). Attach the two VKR Arm Cushions (50) to the Right & Left VKR (33&34), using four M8X65mm Hex Bolts (106) and four M8 Washers (114).

# INSTALLING THE CABLES

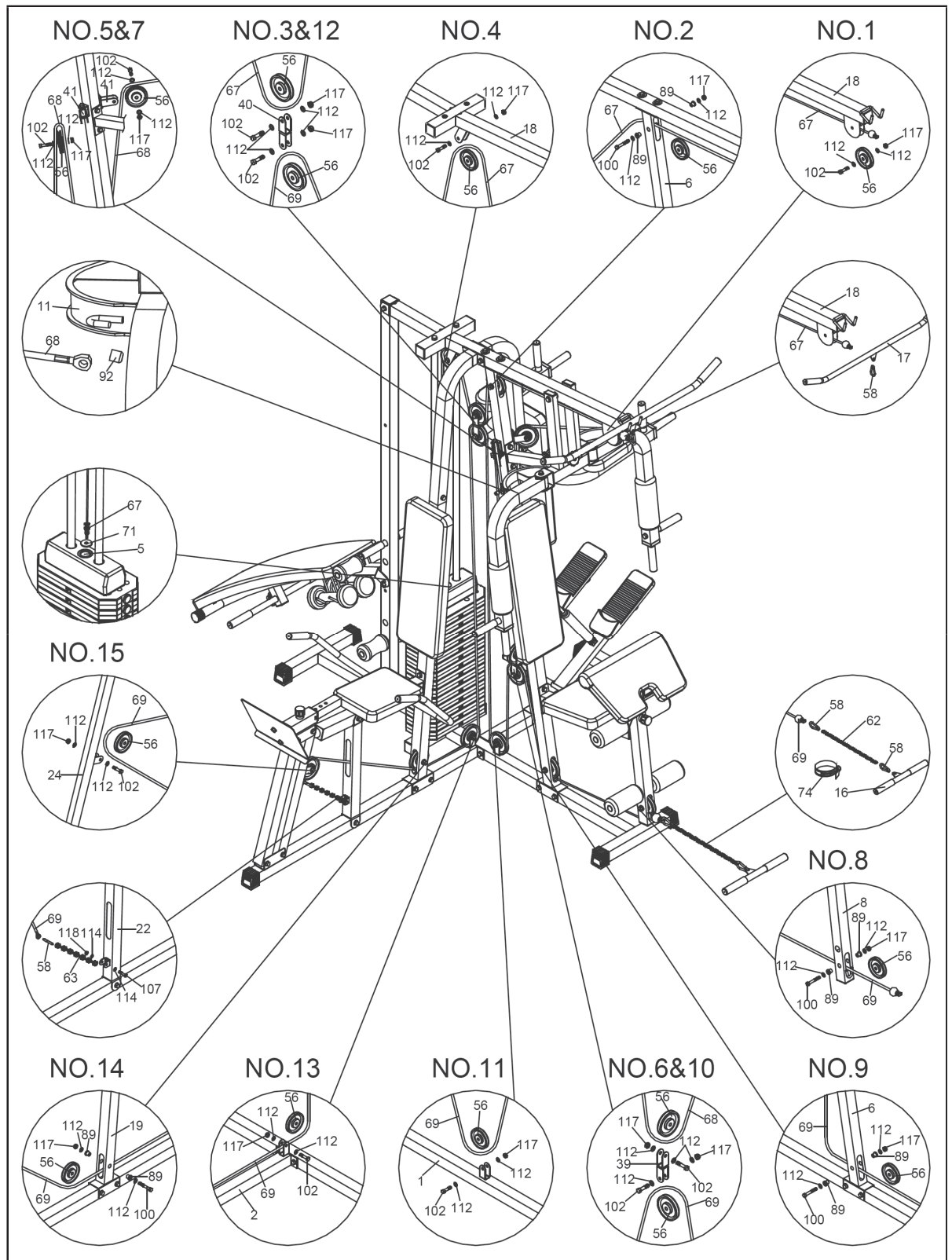

### 1. Start with the Upper Cable (67)

- (a) With Upper Cable (67) in groove of Pulley (56), thread Upper Cable (67) through Upper Cross Beam (18).
- (b) Install Pulley No.1 (56) to Upper Cross Beam (18), using one M10X45mm Hex Bolt (102), two M10 Washers (112) and one M10 Nylon Nut (117).
- (c) Install Pulley No.2 (56) and two Pulley Bushings (small) (89) to Support Frame (6), using one M10X70mm Hex Bolt (100), two M10 Washers (112) and one M10 Nylon Nut (117).
- (d) Install Pulley No.4 (56) to Upper Cross Beam (18), using one M10X45mm Hex Bolt (102), two M10 Washers (112) and one M10 Nylon Nut (117).
- (e) Attach the bolt end of Upper Cable (67) to Selector Shaft (5) with Plastic Washer (71).
- (f) Install Pulley No.3 (56) to Pulley U (40), using one M10X45mm Hex Bolt (102), two M10 Washers (112) and one M10 Nylon Nut (117).
- (g) Attach Lat Bar (17) to the other end of Upper Cable (67), using one Pothook (58).

### 2. Assembly the Butterfly Cable (68)

- (a) Attach both ends of Butterfly Cable (68) to Right & Left Butterfly Arm (11&12), using two Plastic Covers (92).
- (b) Install Pulley No.5&7 (56) to two Single Pulley Blocks (41), using two M10X45mm Hex Bolts (102), four M10 Washers (112) and two M10 Nylon Nuts (117).
- (c) Install Pulley No.6 (56) to Reverse U (39), using one M10X45mm Hex Bolt (102), two M10 Washers (112) and one M10 Nylon Nut (117).

### 3. Assembly the Lower Cable (69)

- (a) With the Lower Cable (69) in groove of Pulley (56) through Leg Extension Frame (8).
- (b) Install Pulley No.8 (56) and two Pulley Bushings (small) (89) to Leg Extension Frame (8), using one M10X70mm Hex Bolt (100), two M10 Washers (112) and one M10 Nylon Nut (117).
- (c) Install Pulley No.9 (56) and two Pulley Bushings (small) (89) to Support Frame (6), using one M10X70mm Hex Bolt (100), two M10 Washers (112) and one M10 Nylon Nut (117).
- (d) Install Pulley No.10 (56) to Reverse U (39), using one M10X45mm Hex Bolt (102), two M10 Washers (112) and one M10 Nylon Nut (117).
- (e) Install Pulley No.11 (56) to Base Frame (1), using one M10X45mm Hex Bolt (102), two M10 Washers (112) and one M10 Nylon Nut (117).
- (f) Install Pulley No.12 (56) to Pulley U (40), using one M10X45mm Hex Bolt (102), two M10 Washers (112) and one M10 Nylon Nut (117).
- (g) Install Pulley No.13 (56) to Leg Press Base Frame (2), using one M10X45mm Hex Bolt (102), two M10 Washers (112) and one M10 Nylon Nut (117).
- (h) Install Pulley No.14 (56) and two Pulley Bushings (small) (89) to Leg Press Lower Support Frame (19), using one M10X70mm Hex Bolt (100), two M10 Washers (112) and one M10 Nylon Nut (117).
- (i) Install Pulley No.15 (56) to Rear Leg Press Upright Frame (24), using one M10X45mm Hex Bolt (102), two M10 Washers (112) and one M10 Nylon Nut (117).
- (j) Attach the bolt end of Lower Cable (69) to Leg Press Seat Support Frame (22), using one Pothook (58), one Short Chain (63), one M8X40mm Hex Bolt (107), two M8 Washers (114) and one M8 Nylon Nut (118).
- (k) Attach Low Bar (16) or Ankle Strap (74) to the other end of Lower Cable (69), using one Long Chain (62) and two Pothooks (58).

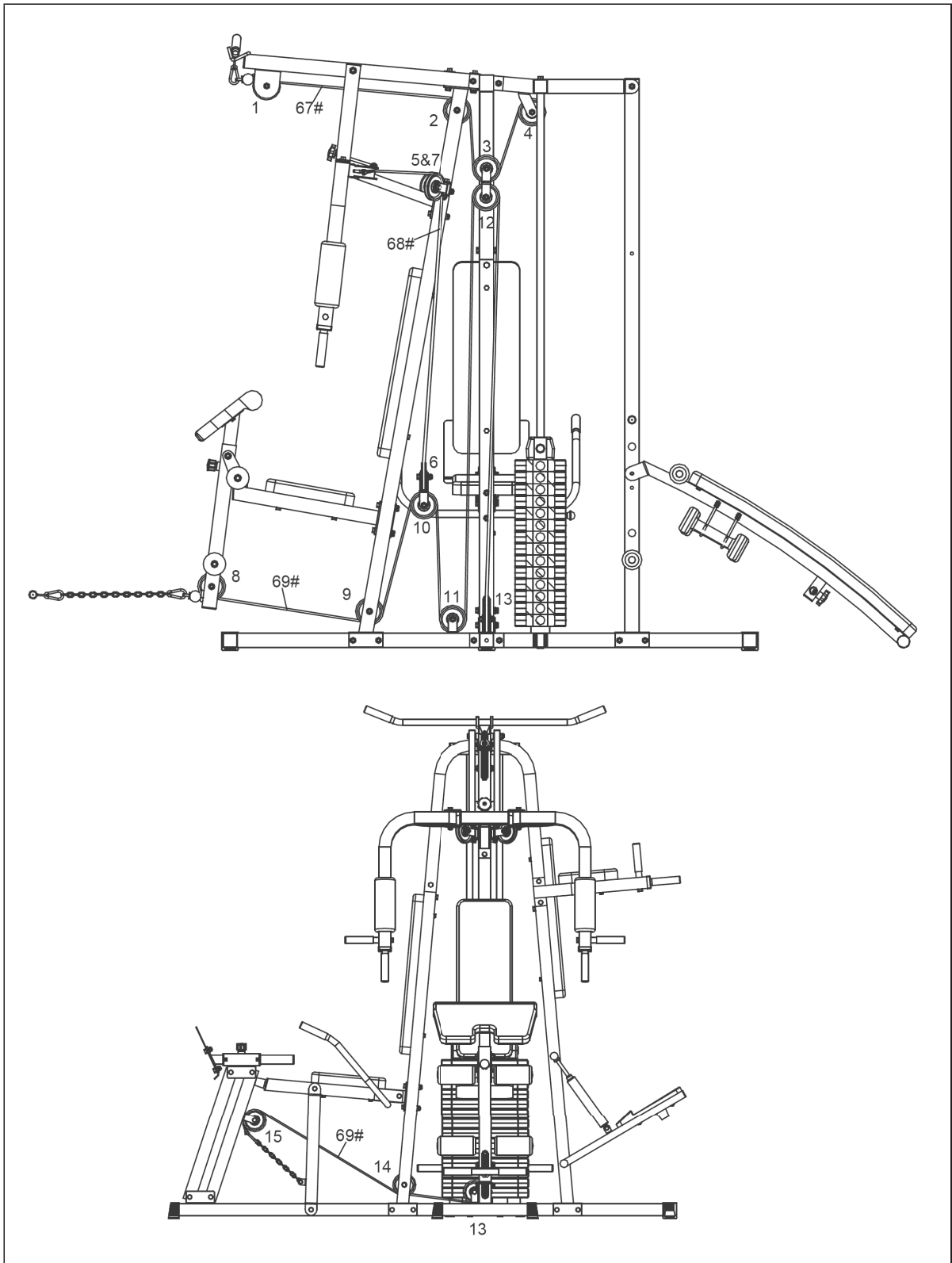



## WARMING UP BEFORE A WORKOUT

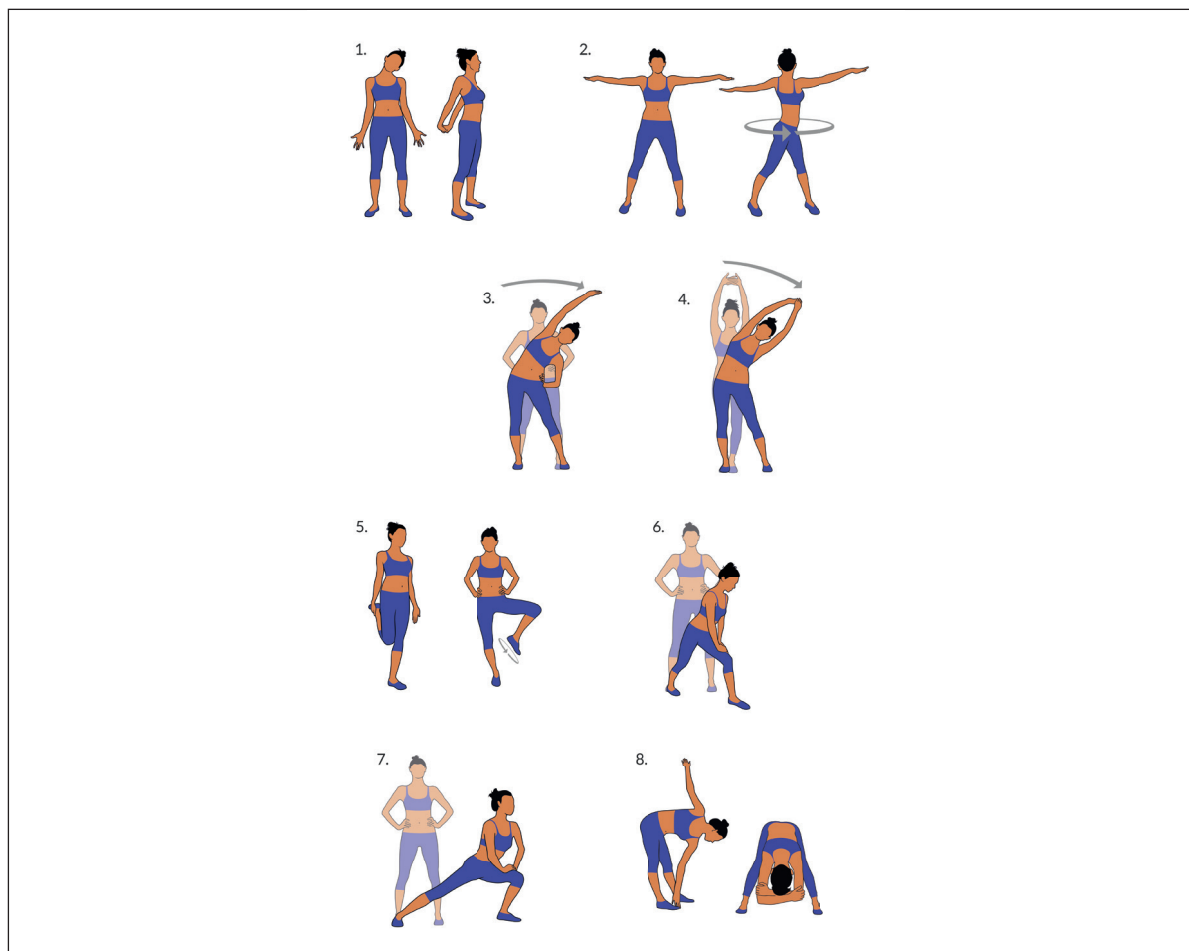

Should a movement be uncomfortable or painful, skip this movement and consult your doctor or fitness instructor about suitable warm-up movements.

Each movement should be repeated (right and left) so that you can start the cardio training relaxed.

### Take about 5 minutes to do the following Klarfit training routine:

1. Tilt the head sideways, slowly alternating from right to left. Then mobilize your shoulders (circular movements and shrugging the shoulders).
2. Turn the hips while the arms are stretched out. The feet are not firmly fixed to the ground (the ankles follow the body's rotation).
3. Bend to the side and raise one arm straight up. Stay in this position for several seconds on each side.
4. Bend to the side and raise both arms above your head with palms together. Again, remain on each side for several seconds. The exercise is now a bit more intense with the second arm joining.
5. Stand on one leg and hold the instep of the other foot with your hand. Mobilize it so as to stretch the thigh lightly. If necessary, hold onto something to keep your balance. Stand on one leg and trace a circle with your foot in the air in both directions (counter clockwise and clockwise).
6. Put one leg forward and with your arms support the weight of your upper body on your thigh. Position your legs so as to provide a stretch for the rear leg's calf muscles.
7. Repeat the previous exercise with more distance between your feet. The stretch will now be more intense.
8. Bend forward while keeping your legs straight and alternatingly touch each hand to the opposite foot. Finally, let yourself hang down and relax.



**Estimado cliente:**

Le felicitamos por la adquisición de este producto. Lea atentamente el siguiente manual y siga cuidadosamente las instrucciones de uso con el fin de evitar posibles daños. La empresa no se responsabiliza de los daños ocasionados por un uso indebido del producto o por haber desatendido las indicaciones de seguridad. Escanee el código QR para obtener acceso al manual de usuario más reciente y otra información sobre el producto.

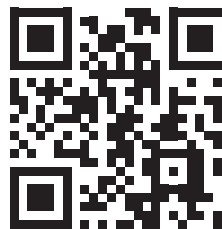

---

## ÍNDICE DE CONTENIDOS

---

Indicaciones de seguridad 52  
Lista de los componentes 53  
Montaje 57  
Instalación de los cables 68  
Calentamiento antes del entrenamiento 71

---

## FABRICANTE E IMPORTADOR (REINO UNIDO)

---

**Fabricante:**

Chal-Tec GmbH, Wallstraße 16, 10179 Berlín, Alemania.

**Importador para Gran Bretaña:**

Berlin Brands Group UK Limited  
PO Box 42  
272 Kensington High Street  
London, W8 6ND  
United Kingdom

---

## CUIDADO Y MANTENIMIENTO

---

**Nota:** Como con todos los dispositivos de entrenamiento con componentes mecánicos móviles, con este producto puede ocurrir que se aflojen los tornillos con un uso frecuente. Por ello, recomendamos controlar regularmente los tornillos y apretarlos con la llave adecuada si fuera necesario. Limpie regularmente el aparato de entrenamiento con un paño húmedo para mantener las superficies libres de sudor y polvo.

- Limpie el aparato regularmente con un paño limpio para mantener una apariencia limpia.
- El uso seguro del aparato solo puede garantizarse si este se limpia regularmente y se inspecciona para detectar daños o desgastes (p. ej. en pedales, manillares, sillín, etc.). Es indispensable sustituir las piezas dañadas y utilizar el aparato solo cuando se haya finalizado dicha reparación.
- Compruebe habitualmente si los tornillos y las tuercas están bien fijados.
- Engrase todas las piezas móviles.











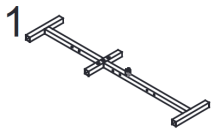
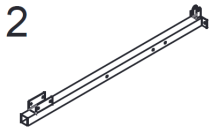
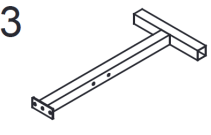



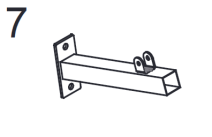
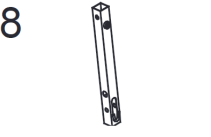
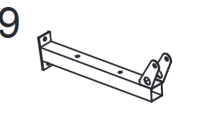
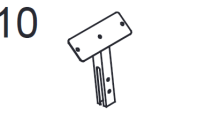

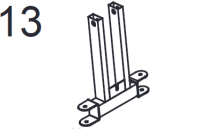
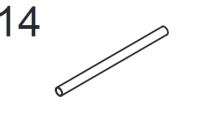

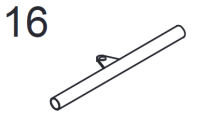
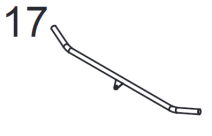
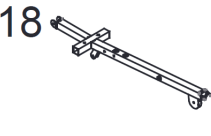
## INDICACIONES DE SEGURIDAD

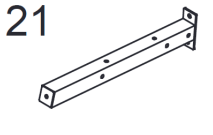
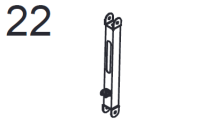
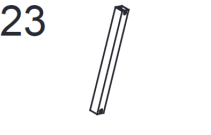
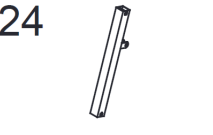
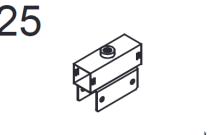
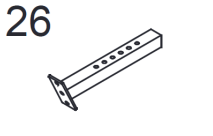

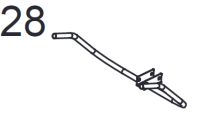
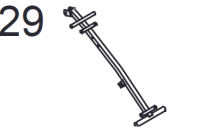
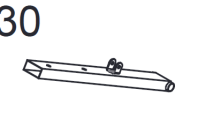

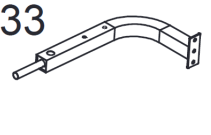
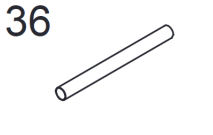
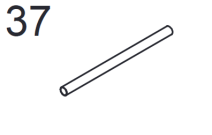
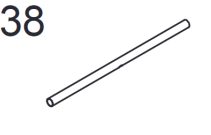
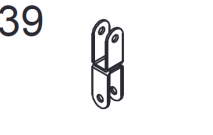













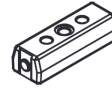
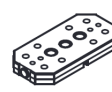





















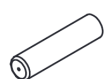



Lea atentamente estas indicaciones de seguridad antes de utilizar el aparato por primera vez y conserve este manual para futuras consultas. Las características del producto pueden variar ligeramente de las representadas en las imágenes. El fabricante puede realizar modificaciones sin aviso previo.

- Conserve este manual en un lugar seguro para que pueda consultarlo en cualquier momento.
- Monte el aparato una vez haya leído todo el manual de instrucciones. La seguridad y la eficacia del mismo solo podrá garantizarse si lo ha montado correctamente y si realiza un mantenimiento y uso idóneos. Asegúrese de que todos los usuarios están informados acerca de las advertencias y medidas de precaución.
- Coloque el aparato en una superficie plana y estable para garantizar un uso seguro. Proteja el suelo con una alfombra. No utilice el aparato en entornos húmedos, como cerca de piscinas, etc. Mantenga una distancia de seguridad de 0,6 metros con el resto de los objetos.
- Antes de iniciar el entrenamiento en el aparato, se recomienda realizar un reconocimiento médico para determinar si tiene algún problema físico o de salud que puede suponer un riesgo para su salud o seguridad, o impedir que pueda utilizar correctamente el aparato. El consejo de su médico es esencial si toma medicamentos que afectan la frecuencia cardíaca, la presión sanguínea o el nivel de colesterol.
- Preste atención a su reacción corporal. Un entrenamiento incorrecto o excesivo puede ser perjudicial para su salud. Detenga el entrenamiento inmediatamente si nota alguno de los siguientes síntomas: dolor, presión en el pecho, ritmo cardíaco irregular, fatiga extrema, vértigo o náuseas. Si tiene uno de los síntomas descritos, debe ponerse en contacto con un médico antes de continuar con el entrenamiento.
- No entrene inmediatamente después de comer.
- Solamente un adulto debe montar el aparato. Mantenga a los niños y mascotas lejos del aparato.
- Este aparato está concebido para ser utilizado en un entorno doméstico.
- El aparato no está indicado para uso terapéutico. Utilice el aparato únicamente para realizar ejercicios ilustrados en este manual de instrucciones.
- Cuando entrene, lleve ropa y calzado apropiados. Evite las prendas sueltas que puedan quedarse enganchadas en el aparato o limitar movimientos.
- Mantenga su espalda recta durante el entrenamiento.
- Antes de cada entrenamiento, asegúrese de que los manillares, el sillín y todos los tornillos y tuercas están montados correctamente.
- Asegúrese de no superar la posición máxima de las piezas móviles y no exceder la marca «Stop», pues existe riesgo de lesiones.
- Utilice el aparato solamente según se describe en estas instrucciones. Si detecta una pieza defectuosa cuando monte o examine el aparato, o si escucha sonidos atípicos durante su uso, detenga inmediatamente el entrenamiento. No utilice el aparato hasta que se haya solucionado el problema.
- Tenga cuidado al levantar o desplazar el aparato para no dañar su espalda. Utilice siempre una técnica de elevación adecuada o solicite ayuda, si es necesario.
- Todas las piezas móviles (p. ej. pedales, manillar, sillín, etc.) deben tener un mantenimiento semanal. Examínelos antes de cada uso del aparato. Si una pieza está rota o suelta, deberá repararla de inmediato. Vuelva a utilizar el aparato cuando se encuentre en perfecto estado.
- Tenga en cuenta que el aparato no tiene ningún sistema de rueda libre por lo que existe riesgo de accidente con un uso inadecuado.
- Mantenga el cable de alimentación lejos de fuentes de calor.
- Nunca introduzca objetos en las ranuras del aparato.
- Apague el aparato y desconecte el cable de alimentación antes de mover el aparato o si está lloviendo. Limpie la superficie del aparato con un producto de limpieza no abrasivo y un paño húmedo. No utilice disolventes.
- No utilice el aparato en lugares que no estén atemperados, como garajes, verandas, cuartos de baño, cocheras o en el exterior.
- Utilice el aparato de acuerdo con lo descrito en estas instrucciones de uso.
- Una reparación incorrecta o una modificación en la estructura del aparato (por ejemplo, retirar o sustituir las piezas originales) puede poner en peligro a los usuarios.
- El volante de inercia alcanza temperaturas elevadas durante el uso del aparato.
- Bloquee el aparato mediante el botón de bloqueo cuando no lo utilice.
- Los niños a partir de los 8 años de edad y las personas con discapacidad mental y física sólo pueden utilizar el aparato si han sido familiarizados con las funciones y las precauciones de seguridad por parte de un supervisor responsable de ellos.
- Asegúrese de que los niños no jueguen con el aparato.
- Antes de su uso, compruebe el voltaje de la placa de características del dispositivo. Conecte el aparato sólo a tomas que correspondan a la tensión del aparato.

**Atención:** Peso máximo soportado: 120 kg.





























LISTA DE LOS COMPONENTES

1 	2 	3 	4 	5 
6 	7 	8 	9 	10 
11 	12 	13 	14 	15 
16 	17 	18 	19 	20 
21 	22 	23 	24 	25 
26 	27 	28 	29 	30 
31 	32 	33 	34 	35 
36 	37 	38 	39 	40 
41 	42 	43 	44 	45 

46 	47 	48 	49 	50 
51 	52 	53 	54 	55 
56 	57 	58 	59 	60 
61 	62 	63 	64 	65 
66 	67 	68 	69 	70 
71 	72 	73 	74 	75 
76 	77 	78 	79 	80 
81 	82 	83 	84 	85 
86 	87 	88 	89 	90 

Núm.	Descripción	Uds.	Núm.	Descripción	Uds.
1	Marco base	1	46	Acolchado para el respaldo	3
2	Marco base para prensa de piernas	1	47	Acolchado para el asiento	2
3	Marco base	1	48	Acolchado para los brazos	1
4	Tubo guía para las pesas	4	49	Acolchado para el banco	1
5	Pin deslizante de selección de peso	1	50	Acolchado para los brazos	2
6	Marco de soporte	1	51	Acolchado para la extensión de las piernas	4
7	Barra de resistencia	1	52	Tubo de espuma para los brazos	2
8	Extensión de las piernas	1	53	Rollos de espuma	4
9	Marco para el asiento	1	54	Placa de pesas superior	1
10	Marco para los brazos	1	55	Placas de pesas	14
11	Brazo de mariposa derecho	1	56	Polea de la correa	15
12	Brazo de mariposa izquierdo	1	57	Pin de selección de peso	1
13	Listón de presión	1	58	Mosquetón	4
14	Tubo largo de espuma	2	59	Bumper (largo)	1
15	Empuñadura	4	60	Bumper (corto)	2
16	Tubo inferior	1	61	Tornillo de sujeción	1
17	Barra de la polea	1	62	Cadena larga	1
18	Barra transversal superior	1	63	Cadena corta	1
19	Soporte inferior (prensa de piernas)	1	64	Tornillo de sujeción	1
20	Soporte superior (prensa de piernas)	1	65	Rodamiento engrasado	2
21	Marco para el asiento (prensa de piernas)	1	66	Pin de seguridad	1
22	Marco del soporte del asiento (prensa de piernas)	1	67	Cable superior	1
23	Marco vertical delantero de la prensa de las piernas	1	68	Cable para las pesas de mariposa	1
24	Marco vertical trasero de la prensa de las piernas	1	69	Cable inferior	1
25	Marco de conexión de la prensa de piernas	1	70	Pin de ajuste	2
26	Placa de ajuste de la prensa de las piernas	1	71	Arandela	1
27	Placa para la prensa de las piernas	1	72	Arandela de plástico	1
28	Pasamanos de la prensa de las piernas	1	73	Pin	1
29	Marco del banco	1	74	Correa	1
30	Marco de los pedales	2	75	Pesa corta	2
31	Marco de soporte inferior	1	76	Arandela de goma	2
32	Marco de soporte superior	1	77	Agarradera	18
33	Arco derecho	1	78	Tapón cuadrado de 50 mm	7
34	Arco izquierdo	1	79	Tapón	1
35	Marco vertical trasero	1	80	Tapón cuadrado central	4
36	Tubo de la agarradera del banco	1	81	Tapón cuadrado 50 mm	8
37	Tubo de espuma corto	1	82	Tapón cuadrado 38 mm	2
38	Empuñadura larga	1	83	Tapón cuadrado de 30x60 mm	2
39	Pieza en forma de U doble inversa	1	84	Tapón cuadrado de 25x50 mm	2
40	Pieza en forma de U doble	1	85	Rodamiento del pedal (grande)	4
41	Pieza individual en forma de U	2	86	Tapón redondo 25 mm	8
42	Gancho para la pesa corta	1	87	Tapón cuadrado central	2
43	Placa	4	88	Pedal	2
44	Pernos (en forma de pipa de tabaco)	1	89	Rodamiento (pequeño)	8
45	Cilindro	2	90	Rodamiento plástico	4

## Piezas pequeñas

91 	92 	93 	94 	95 
96 	97 	98 	99 	100 
101 	102 	103 	104 	105 
106 	107 	108 	109 	110 
111 	112 	113 	114 	115 
116 	117 	118 		

Núm.	Descripción	Uds.	Núm.	Descripción	Uds.
91	Tapón redondo 38 mm	2	105	Tornillo M10x20 mm	4
92	Cubierta de plástico	2	106	Tornillo allen M8x65 mm	16
93	Tapón cuadrado 38 mm	1	107	Tornillo allen M8x40 mm	4
94	Tapón amortiguador	2	108	Tornillo allen M8x16mm	10
95	Tapón con rosca	4	109	Tornillo M6x40 mm	4
96	Tornillo allen M12x150 mm	1	110	Arandela M12	4
97	Tornillo allen M12x75 mm	1	111	Arandela Ø30xØ10	1
98	Tornillo allen M10x85 mm	2	112	Arandela M10	111
99	Tornillo allen M10 x 75 mm	6	113	Arandela Ø25xØ8	4
100	Tornillo allen M10x70 mm	29	114	Arandela M8	32
101	Tornillo allen M10x65 mm	2	115	Arandela M6	4
102	Tornillo allen M10x45 mm	11	116	Tuerca de nylon M12	2
103	Tornillo allen M10x25 mm	2	117	Tuerca de nylon M10	52
104	Tornillo allen M10x20 mm	7	118	Tuerca de nylon M8	6



## MONTAJE

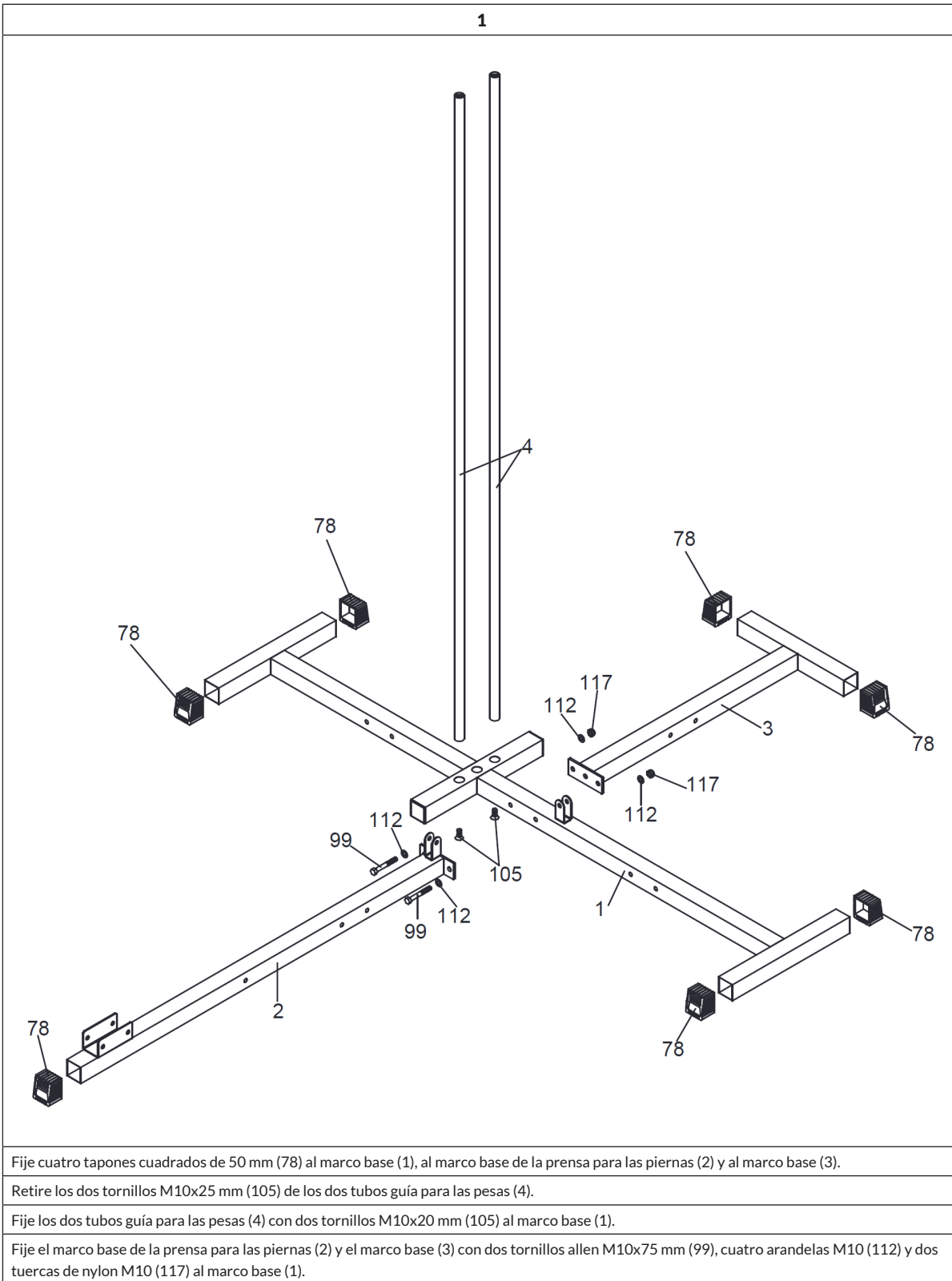

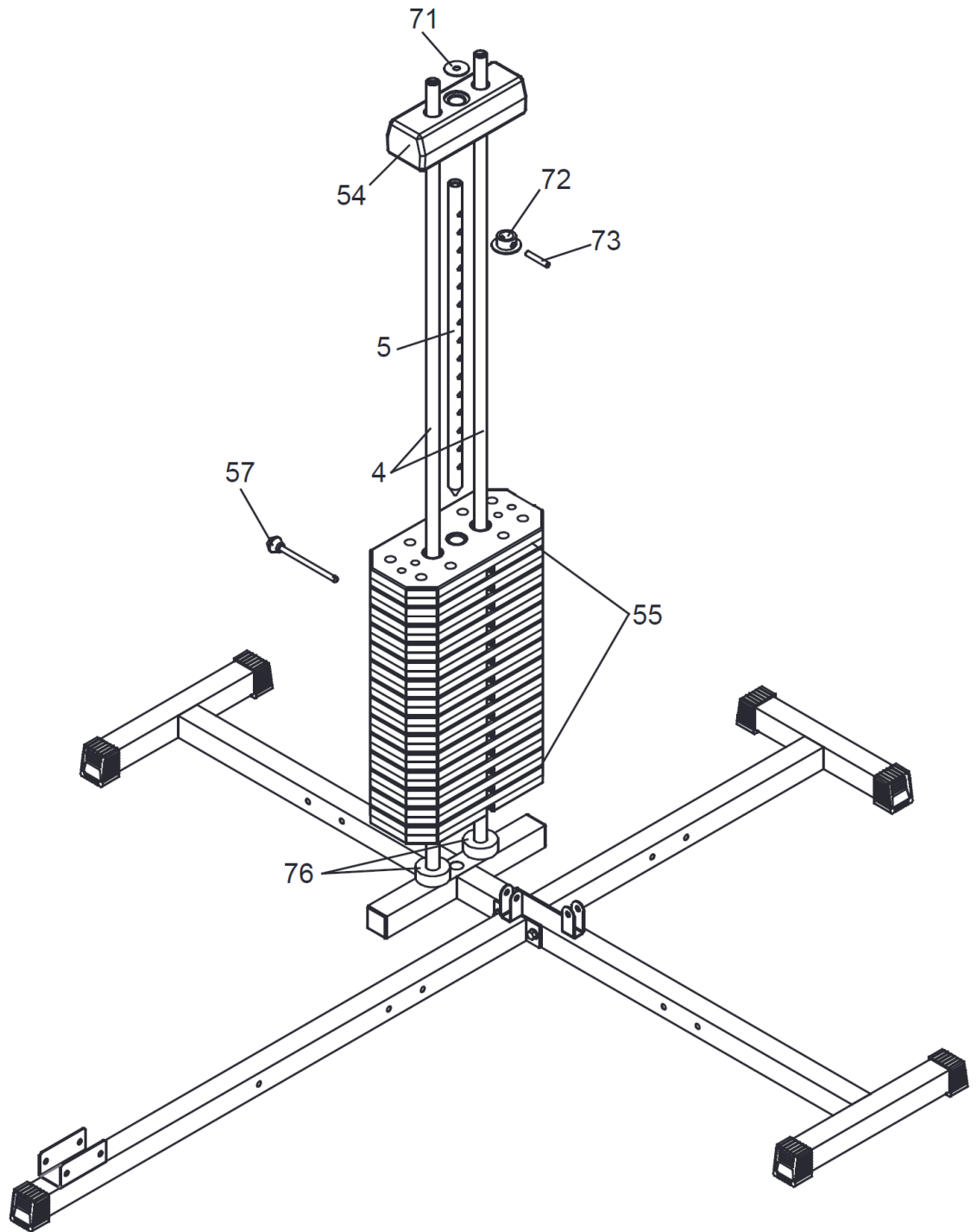

Desplace las dos arandelas de goma (76) por el tubo guía (4).

Pase las 14 placas de pesas (55) por el tubo guía (4).

Pase la anilla de plástico (72) a lo largo del pin deslizable de selección (5) hacia abajo y fíjela con el pin (73) en el orificio superior.

Coloque el pin deslizable de selección (5) en el orificio de las placas de pesas (55).

Pase la placa de pesas superior (54) por el tubo guía (4) y encaje el pin de selección de peso (57) en el orificio de la pesa deseada.

Coloque la arandela (71) en la placa de pesa superior (54).

3

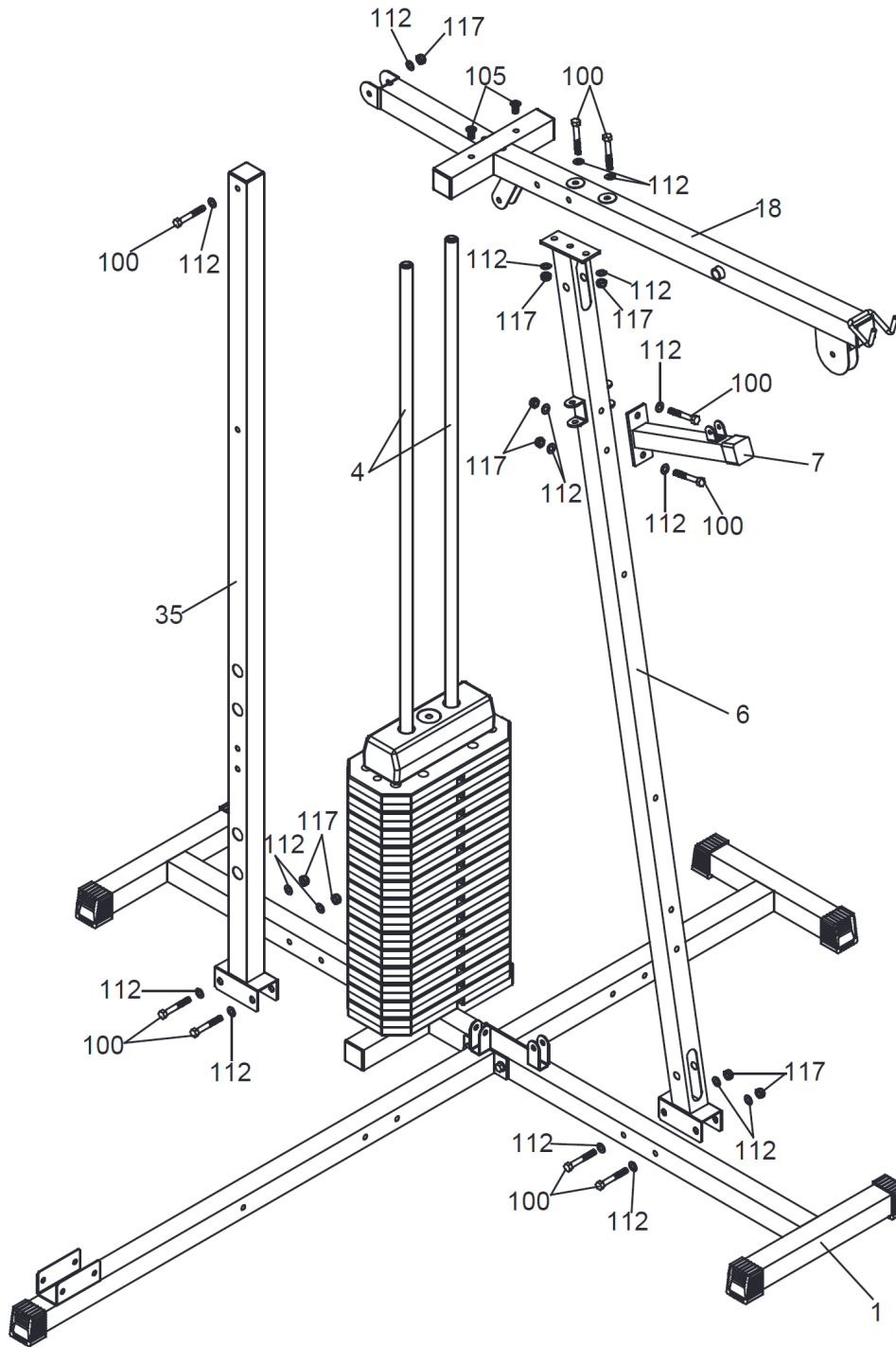

Fije el marco de soporte (6) y el marco vertical trasero (35) con cuatro tornillos allen M10x70 mm (100), ocho arandelas M10 (112) y cuatro tuercas de nylon M10 (117) al marco base (1).

Retire los dos tornillos M10x25 mm (105) de los dos tubos guía (4).

Fije la barra transversal superior (18) con dos tornillos M10x25 mm (105) a ambos tubos guía (4).

Fije la barra transversal superior (18) con tres tornillos allen M10x70 mm (100), seis arandelas M10 (112) y tres tuercas de nylon M10 (117) al marco de soporte (6) y al marco vertical trasero (35).

Fije la barra de resistencia (7) con dos tornillos allen M10x70 mm (100), cuatro arandelas M10 (112) y dos tuercas de nylon M10 (117) al marco de soporte (6).

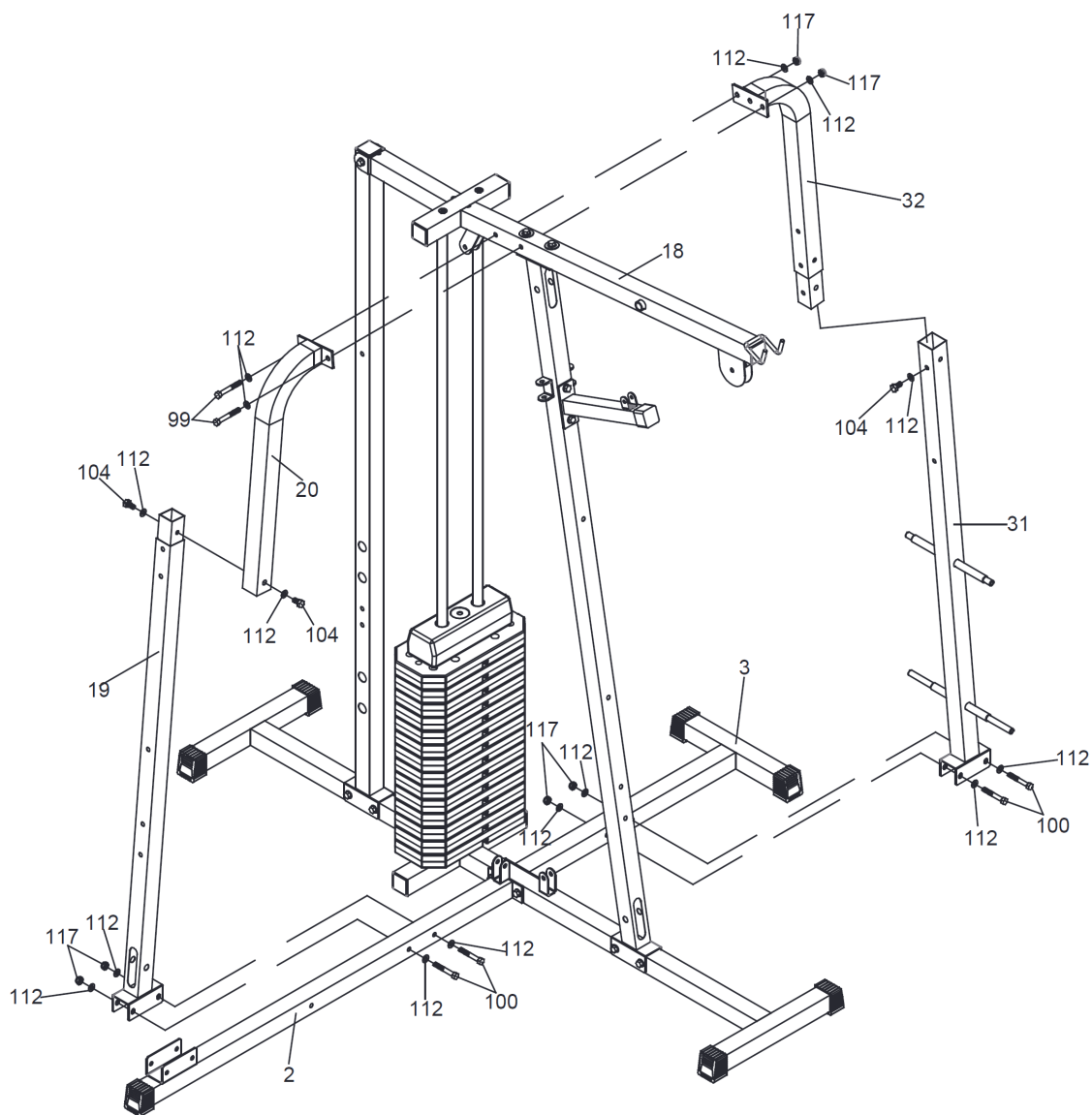

Fije el soporte inferior (19) de la prensa para las piernas con dos tornillos allen M10x70 mm (100), cuatro arandelas M10 (112) y dos tuercas de nylon M10 (117) al marco base (2) de la prensa para las piernas.

Fije el marco inferior del asiento (31) con dos tornillos allen M10x70 mm (100), cuatro arandelas M10 (112) y dos tuercas de nylon M10 (117) al marco base (3).

Fije el soporte superior (20) de la prensa para las piernas con dos tornillos allen M10x70 mm (104) y dos arandelas M10 (112) al marco inferior (19) de la prensa para las piernas.

Fije el marco de soporte superior (32) con un tornillo allen M10x20 mm (104) y una arandela M10 (112) al marco de soporte inferior (31).

Fije el soporte superior (20) de la prensa para las piernas al marco de soporte superior (32) con dos tornillos allen M10x75 mm (99), cuatro arandelas M10 (112) y dos tuercas de nylon M10 (117) a la barra transversal superior (18).

5

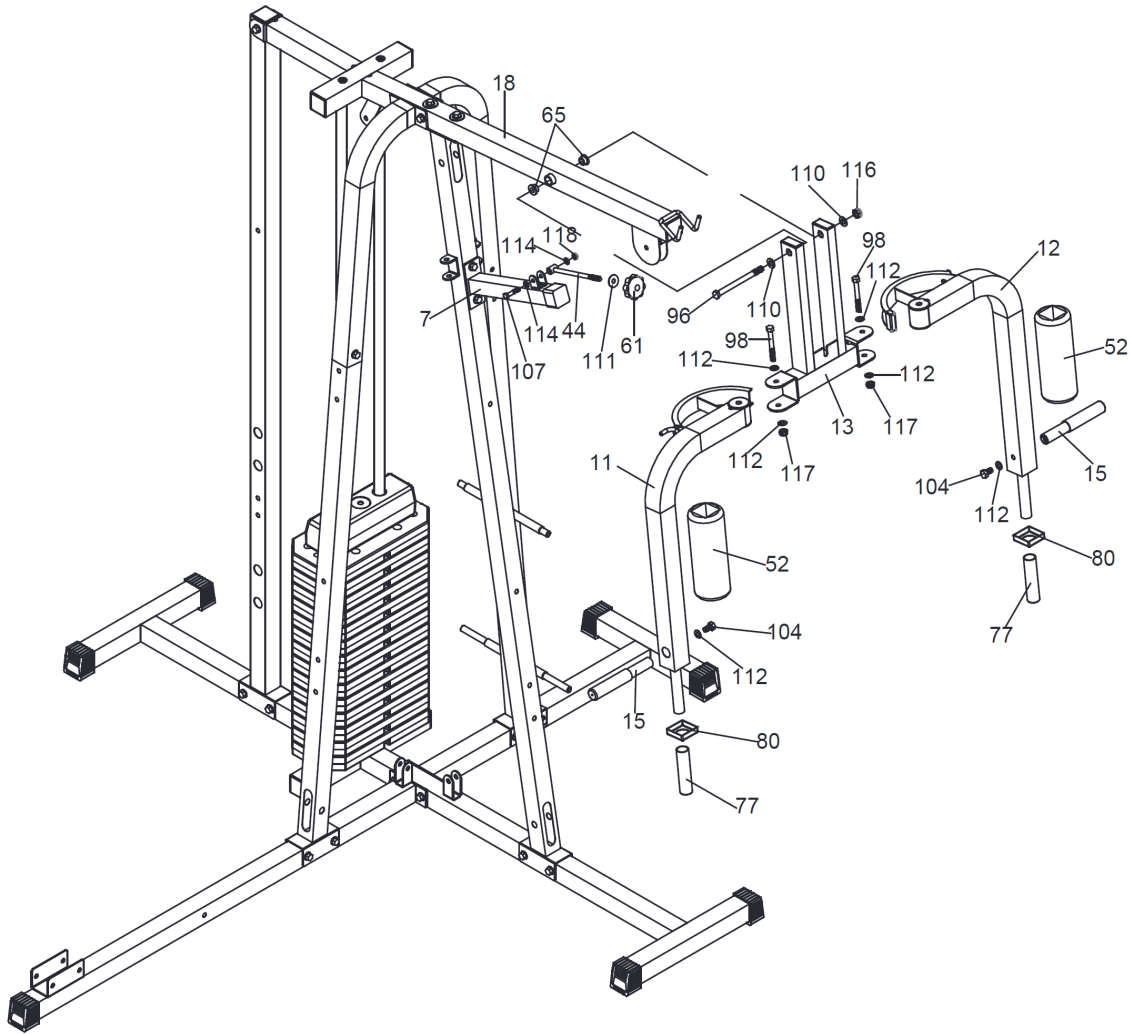

**Nota:** El rodamiento engrasado (65) está premontado en la barra transversal (18).

Fije el listón de presión (13) con un tornillo allen M12x150 mm (96), dos arandelas M12 (110) y una tuerca de nylon M2 (116) a la barra transversal superior (18).

Fije el brazo derecho e izquierdo de mariposa (11 y 12) con dos tornillos allen M10x85mm (98), cuatro arandelas M10 (112) y dos tuercas de nylon M10 (117) al listón de presión (13).

Deslice dos rollos de espuma (52) por el brazo izquierdo y derecho de mariposa (11 y 12).

Retire los dos tornillos allen M10x20 mm (104) y dos arandelas M10 (112) de ambas empuñaduras (15).

Fije ambas empuñaduras (15) con dos tornillos allen M10x20 mm (104) y dos arandelas M10 (112) al brazo izquierdo y derecho de mariposa (11 y 12).

Deslice ambos tapones cuadrados centrales (80) y las dos agarraderas (77) por los brazos izquierdo y derecho de mariposa (11 y 12).

Fije los pernos (44) con un tornillo allen M8x40 mm (107), dos arandelas M8 (114) y una tuerca M8 (118) a la barra de resistencia (7).

Deslice la arandela (111) y el tornillo de ajuste (61) en los pernos (44).

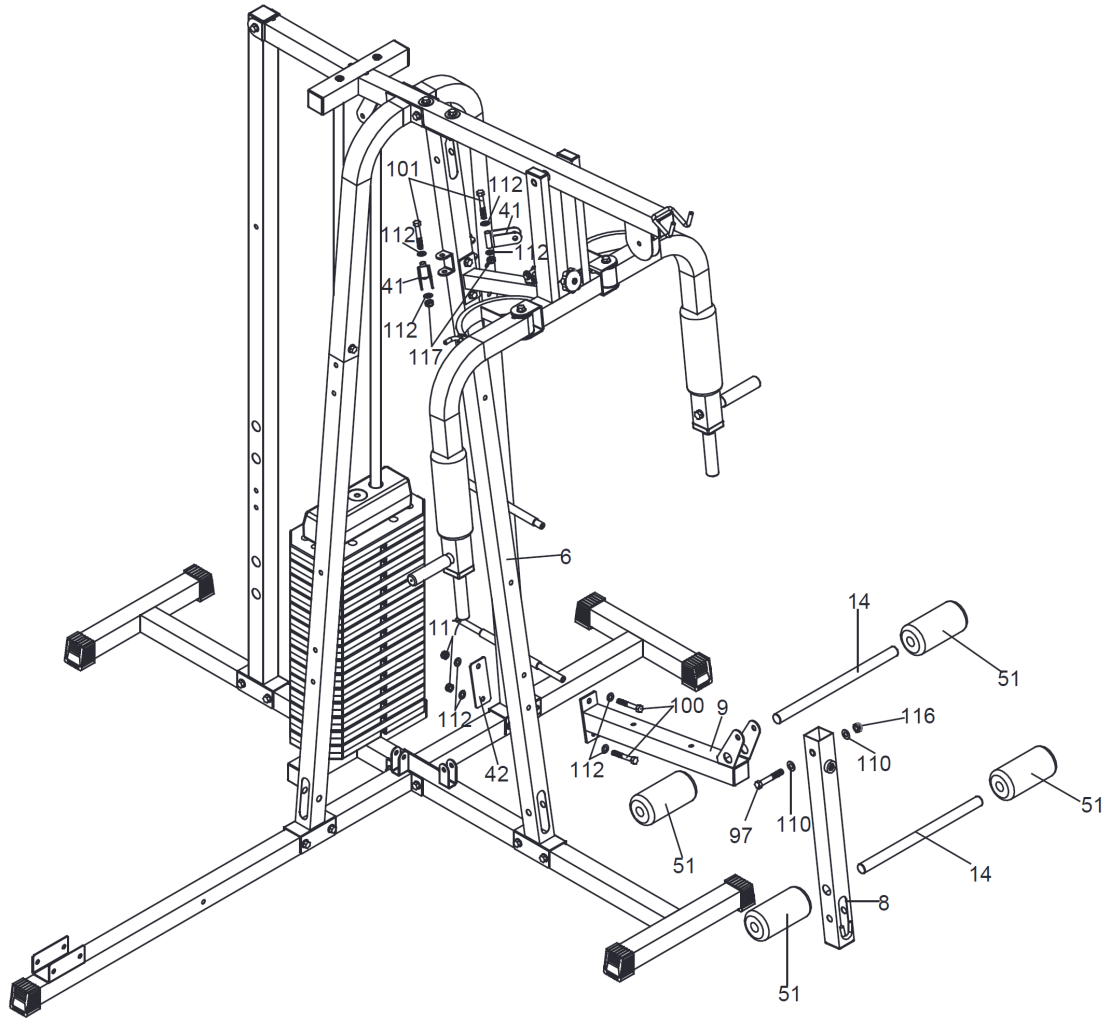

Fije el marco del asiento (9) y la placa (42) con dos tornillos allen M10x70 mm (100), cuatro arandelas M10 (112) y dos tuercas de nylon M10 (117) al marco de soporte (6).

Fije la extensión para las piernas (8) con un tornillo allen M12x75 mm (97), dos arandelas M12 (110) y una tuerca de nylon M12 (116) al marco del asiento (9).

Coloque ambos tubos de espuma largos (14) en la extensión de las piernas (8) y en el marco del asiento (9).

Desplace el acolchado para la extensión de las piernas (51) por el tubo de espuma largo (14).

Fije la pieza en forma de U (41) con dos tornillos allen M10x65 mm (101), cuatro arandelas M10 (112) y dos tuercas de nylon M10 (117) al marco de soporte (6).

7

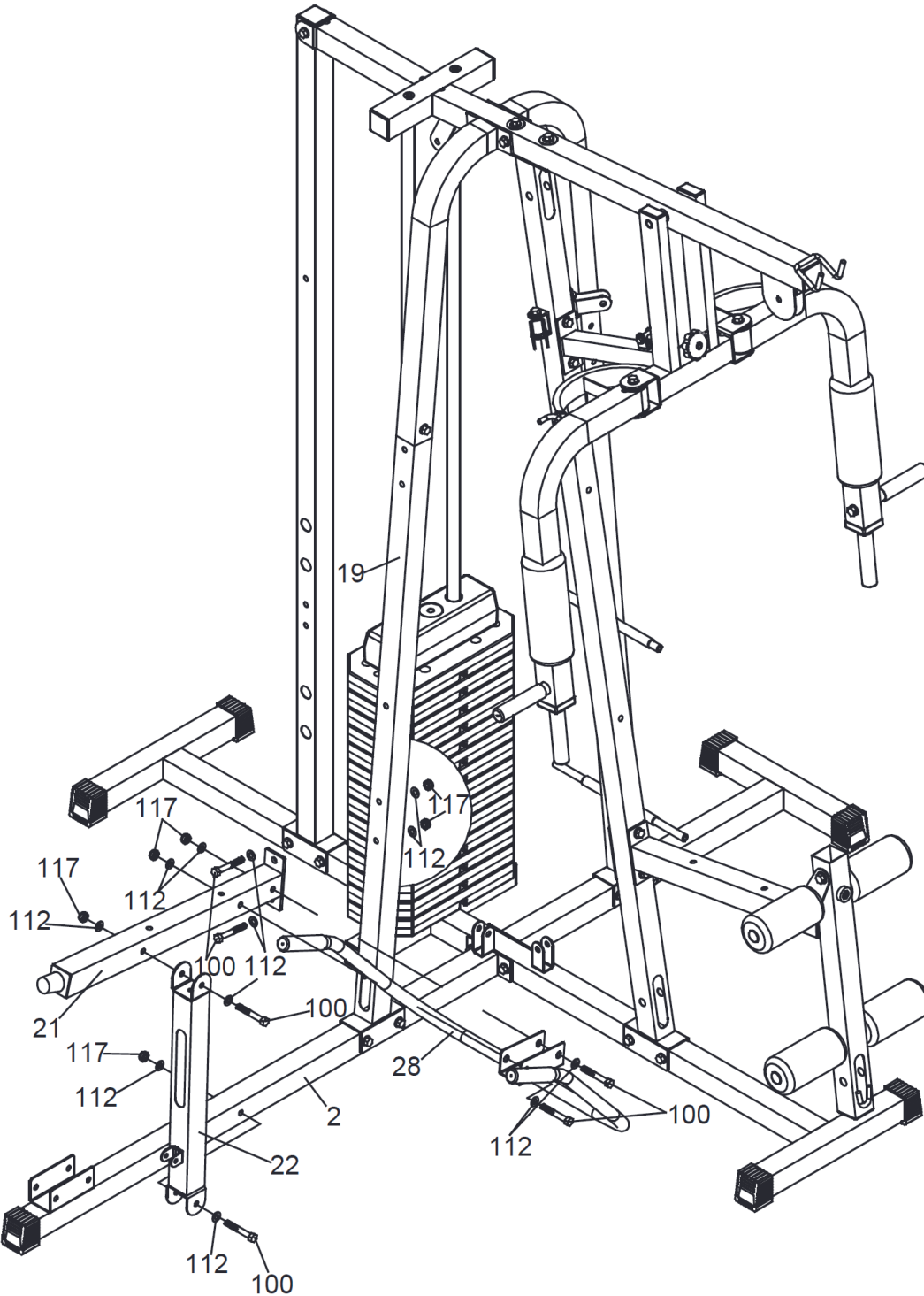

Fije el marco del soporte del asiento (22) de la prensa para las piernas con un tornillo allen M10x70 mm (100), dos arandelas M10 (112) y una tuerca de nylon M10 (117) al marco base (2) de la prensa para las piernas.

Fije el marco del asiento (21) con tres tornillos allen M10x70 mm (100), seis arandelas M10 (112) y tres tuercas de nylon M10 (117) al soporte inferior (19) y al marco del soporte del asiento (22).

Fije el pasamanos (28) con dos tornillos allen M10x70 mm (100), cuatro arandelas M10 (112) y dos tuercas de nylon M10 (117) al marco del asiento (21).

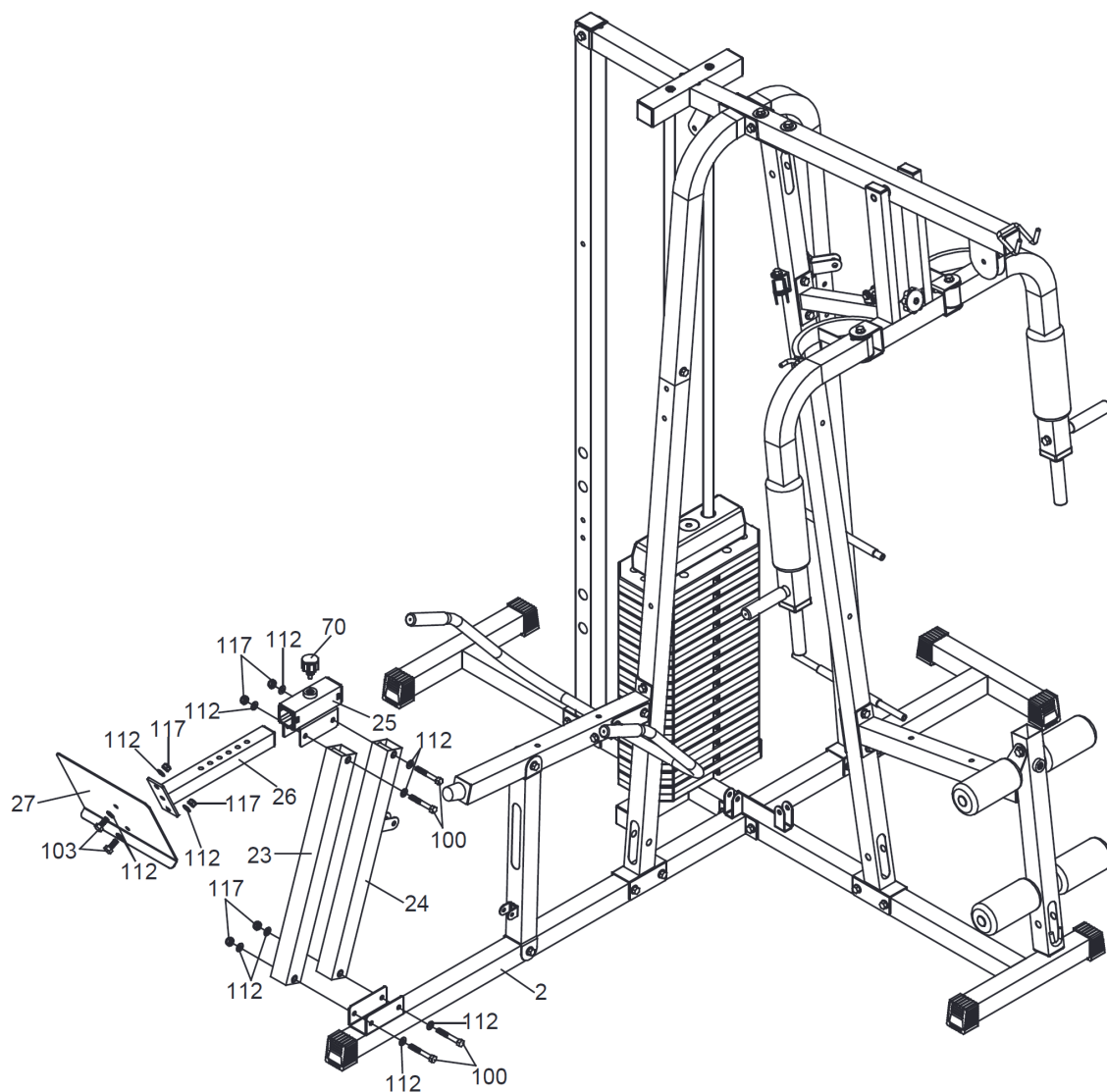

Fije el marco vertical delantero (23) al marco vertical trasero (24) con dos tornillos allen M10x70 mm (100), cuatro arandelas M10 (112) y dos tuercas de nylon M10 (117) al marco base de la prensa para las piernas (2).

Fije el marco de conexión (25) con dos tornillos allen M10x70 mm (100), cuatro arandelas M10 (112) y dos tuercas de nylon M10 (117) al marco vertical delantero (23) y trasero (24).

Fije la placa de la prensa para las piernas (27) con dos tornillos allen M10x25 mm (103), cuatro arandelas M10 (112) y dos tuercas de nylon M10 (117) al marco de ajuste (26).

Coloque el marco de ajuste (26) en el marco de conexión (25) de la prensa para las piernas y fije el pin de ajuste (70).



9

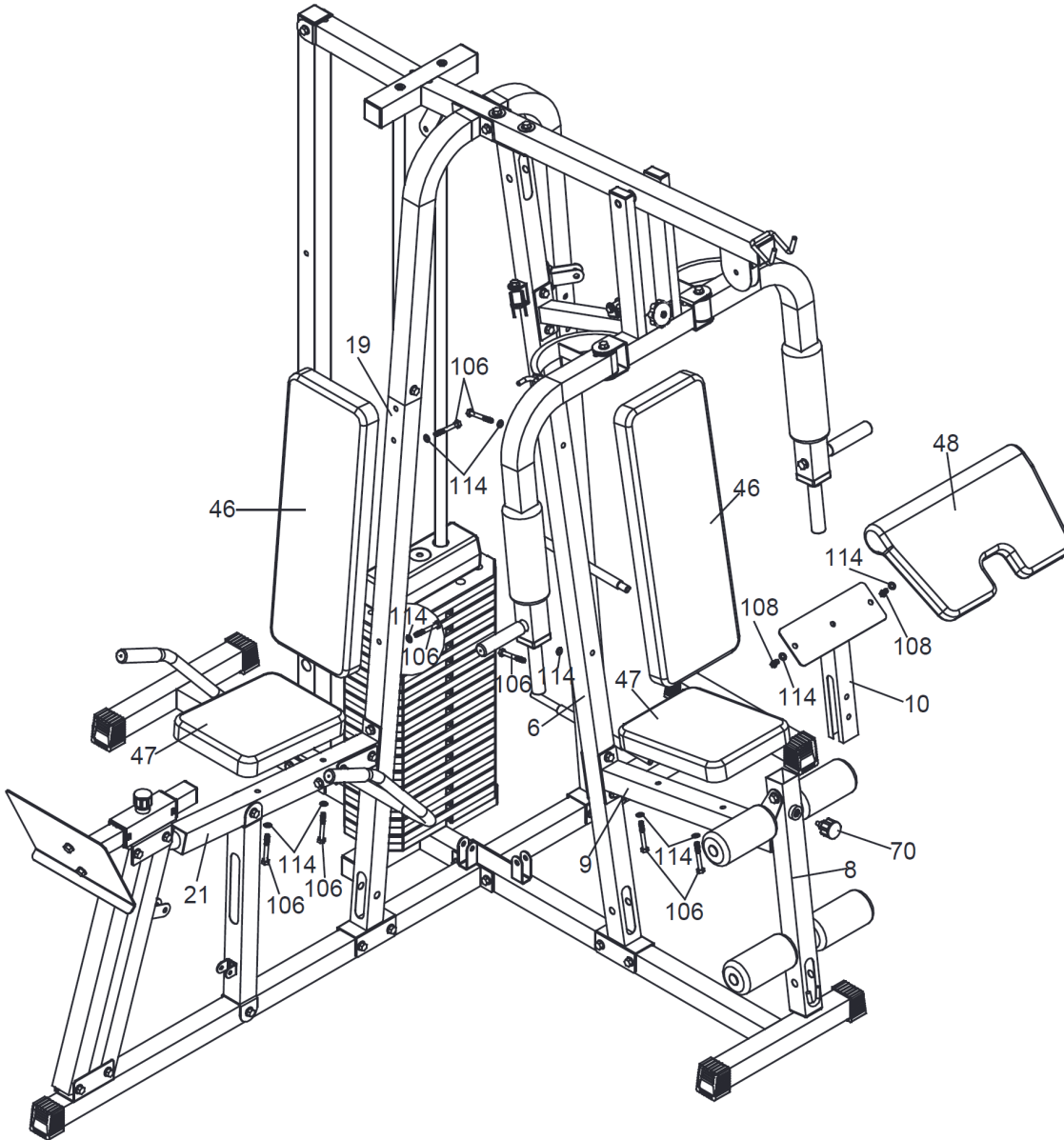

Fije ambos acolchados para el respaldo (46) con cuatro tornillos allen M8x65 mm (106) y cuatro arandelas M8 (114) al marco de soporte (6) y al soporte inferior (19).

Fije ambos acolchados para el asiento (47) con cuatro tornillos allen M8x65 mm (106) y cuatro arandelas M8 (114) al marco del asiento (9) y al marco del asiento de la prensa para las piernas (21).

Fije ambos acolchados para los brazos (48) con dos tornillos allen M8x16 mm (108) y dos arandelas M8 (114) al marco para los brazos (10).

Coloque el marco para los brazos (10) a la extensión para las piernas (8) y fíjelo con el botón de ajuste (70).

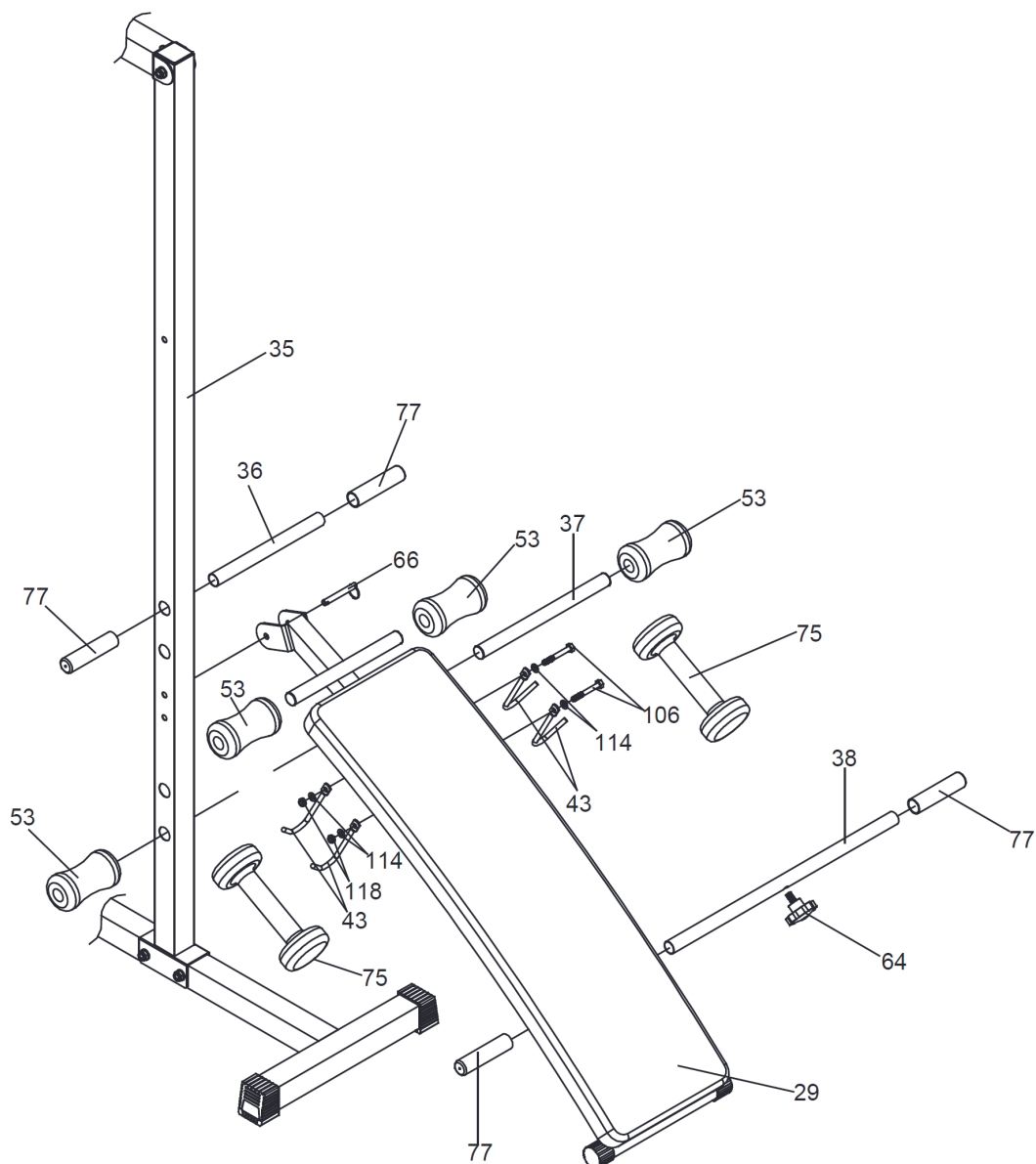

Fije los cuatro ganchos de la pesa corta (43) con dos tornillos allen M8x65 mm (106), cuatro arandelas M8 (114) y dos tuercas de nylon M8 (118) al marco del banco (29). Coloque las dos pesas cortas (75) sobre los ganchos.

Coloque la empuñadura larga (38) en el marco del banco (29) y fije el tornillo de sujeción (64). Deslice ambas agarraderas (77) por la empuñadura (38).

Fije el marco del banco (29) con el pin de seguridad (66) al marco vertical trasero (35).

Pase el tubo de la agarradera del banco (36) por el marco vertical trasero (35). Deslice ambas (77) por la empuñadura del banco (36).

Coloque el tubo de espuma corto (37) en el marco del banco (29). Pase los cuatro rollos de espuma (53) por la barra larga (37) el marco del banco (29).

11

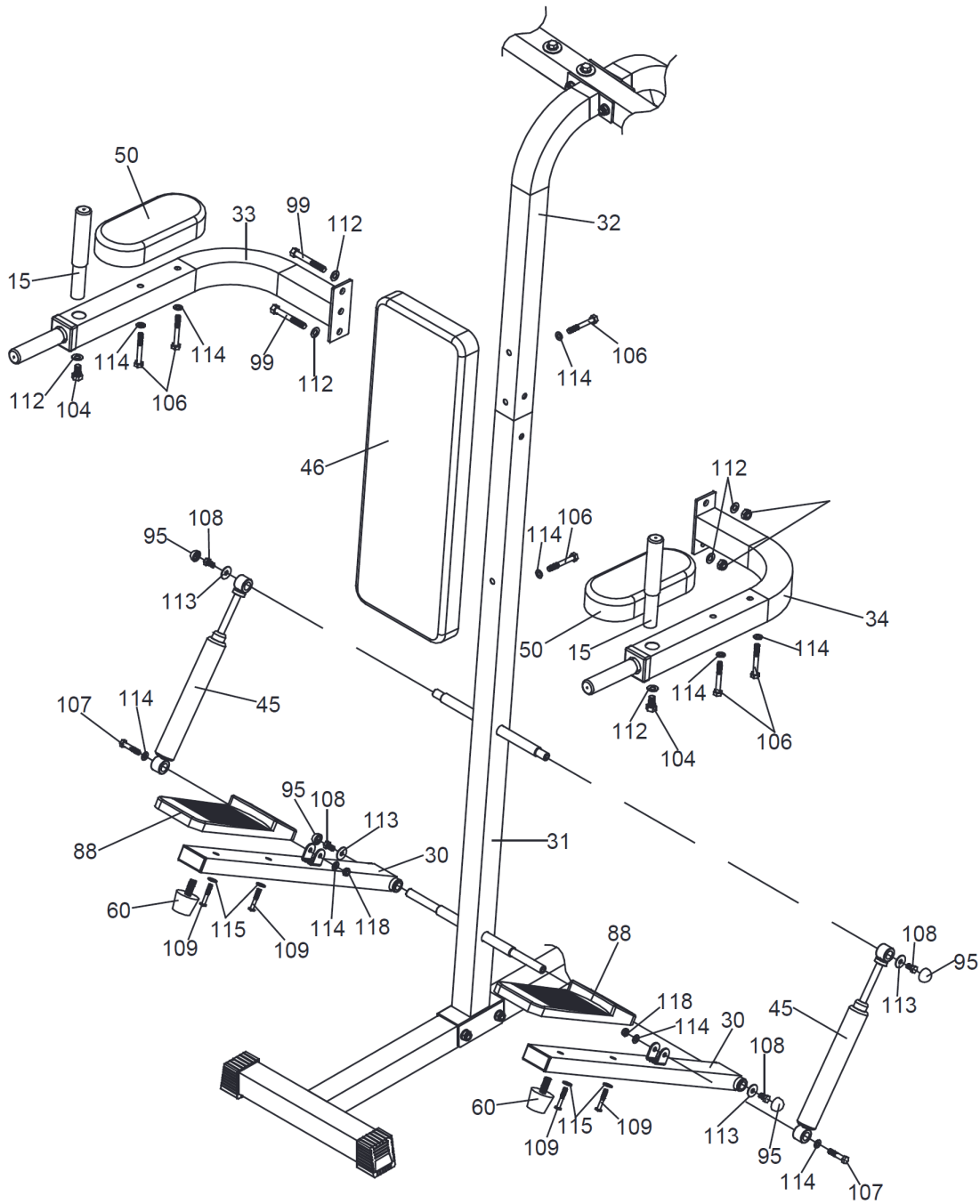

Fije los pedales (88) con cuatro tornillos (109) y cuatro arandelas M6 (115) al marco del pedal (30). Fije los dos bumper (60) a los dos marcos de los pedales (30). Fije ambos marcos de los pedales (30) con dos tornillos allen (108), dos arandelas (113) y dos tapas (95) al marco inferior de soporte (31).

Fije ambos cilindros (45) con dos tornillos allen (108), dos arandelas (113) y dos tapas (95) al marco inferior de soporte (31). Fije ambos cilindros (45) con dos tornillos allen (107), cuatro arandelas (114) y tuercas de nylon (118) a los marcos de los pedales (30).

Fije el arco derecho e izquierdo (33 y 34) con dos tornillos allen (99), cuatro arandelas (112) y dos tuercas de nylon M10 (117) al marco de soporte inferior (31) y superior (32). Fije las empuñaduras (15) con dos tornillos allen (104) y dos arandelas (112) a los arcos izquierdo y derecho (33 y 34).

Fije el acolchado para el respaldo (46) con dos tornillos allen (106) y dos arandelas (114) al marco de soporte inferior (31) y superior (32). Fije ambos acolchados para los brazos (50) con cuatro tornillos allen (106) y cuatro arandelas (114) a los elementos curvados izquierdo y derecho (33 y 34).

# INSTALACIÓN DE LOS CABLES

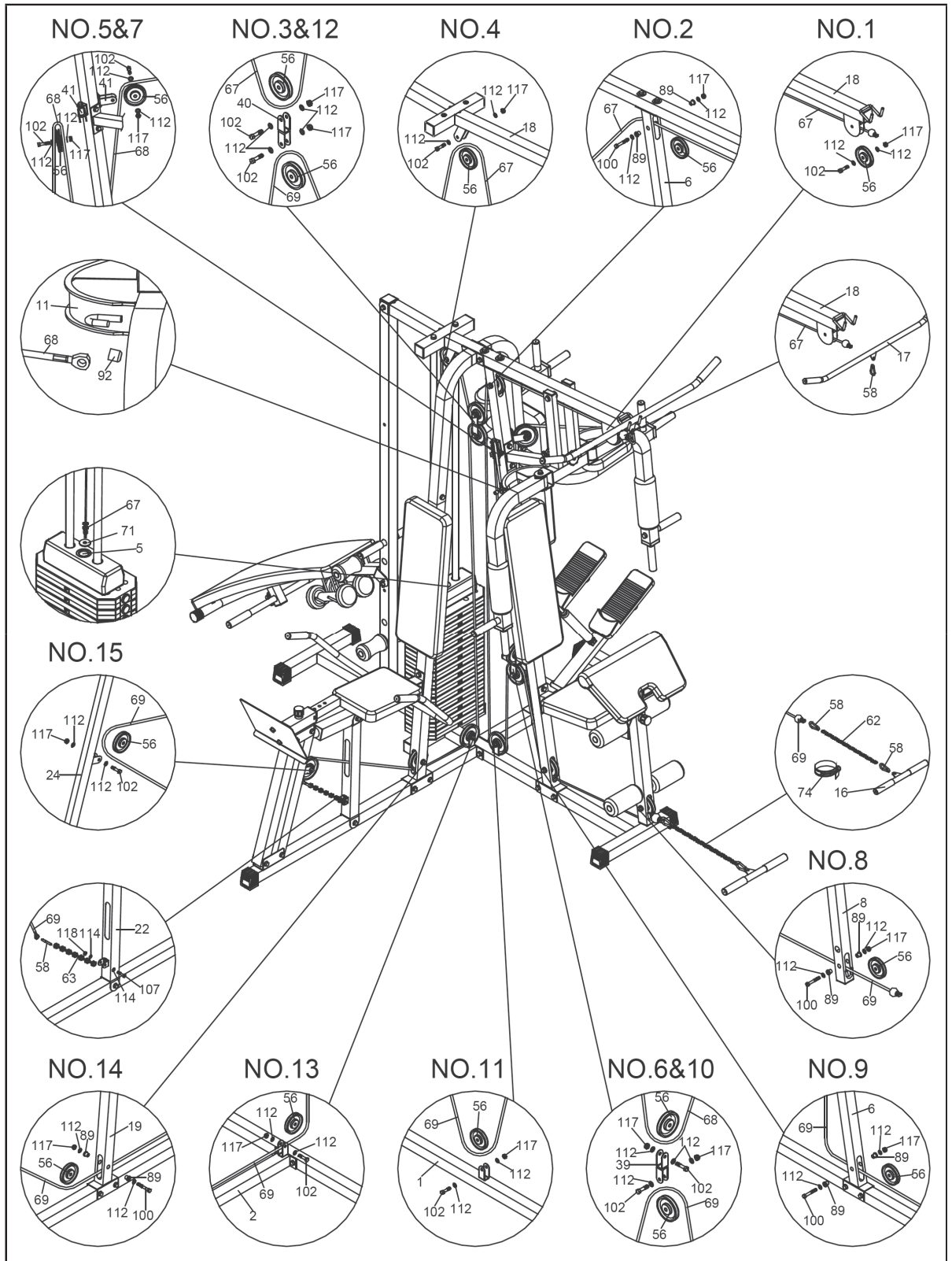

### Comience con el cable superior (76)

- (a) Pase el cable superior (67), utilizando el ojal de la polea de la correa (56), por la barra transversal superior (18).
- (b) Monte la polea de la correa (56) como se muestra en la imagen „Núm. 1“ con un tornillo allen M10x45 mm (102), dos arandelas M10 (112) y una tuerca de nylon M10 (117) en la barra transversal superior (18).
- (c) Monte la polea de la correa (56) y ambos rodamientos pequeños como se muestra en la imagen „número 2“ con un tornillo allen M10x70 mm (100), dos arandelas M10 (112) y una tuerca de nylon M10 (117) al marco de soporte (6).
- (d) Monte la polea de la correa (56) como se muestra en la imagen „Núm. 3“ con un tornillo allen M10x45 mm (102), dos arandelas M10 (112) y una tuerca de nylon M10 (117) en la barra transversal superior (18).
- (e) Fije el extremo del perno del cable superior (67) con una arandela (71) al pin deslizante (5).
- (f) Monte la polea de la correa (56) como se muestra en la imagen „Núm. 3“ con un tornillo allen M10x45 mm (102), dos arandelas M10 (112) y una tuerca de nylon M10 (117) en la pieza doble con forma de U (40).
- (g) Fije la barra de la polea (17) con el mosquetón (58) al otro extremo del cable superior (67).

### 2. Montaje del cable para la pesa mariposa (68)

- (a) Fije ambos extremos del cable de mariposa (68) con dos tornillos a las pesas mariposa izquierda y derecha (11 y 12) y a continuación fije las cubiertas de plástico (92).
- (b) Monte la polea de la correa (56) como se muestra en las imágenes „5 y 7“ con dos tornillos allen M10x45 mm (102), cuatro arandelas M10 (112) y dos tuercas de nylon M10 (117) en la pieza individual con forma de U (41).
- (c) Monte la polea de la correa (56) como se muestra en la imagen „Núm. 6“ con un tornillo allen M10x45 mm (102), dos arandelas M10 (112) y una tuerca de nylon M10 (117) en la pieza doble con forma de U (39).

### 3. Montaje del cable inferior (69)

- (a) Pase el cable inferior (69), utilizando el ojal de la polea de la correa (56), por la extensión de las piernas (8).
- (b) Monte la polea de la correa (56) y ambos rodamientos pequeños (89) como se muestra en la imagen „número 8“ con un tornillo allen M10x70 mm (100), dos arandelas M10 (112) y una tuerca de nylon M10 (117) en la extensión de las piernas (8).
- (c) Monte la polea de la correa (56) y ambos rodamientos pequeños (89) como se muestra en la imagen „número 9“ con un tornillo allen M10x70 mm (100), dos arandelas M10 (112) y una tuerca de nylon M10 (117) al marco de soporte (6).
- (d) Monte la polea de la correa (56) como se muestra en la imagen „Núm. 10“ con un tornillo allen M10x45 mm (102), dos arandelas M10 (112) y una tuerca de nylon M10 (117) en la parte trasera de la pieza con forma de U (39).
- (e) Monte la polea de la correa (56) como se muestra en la imagen „Núm. 11“ con un tornillo allen M10x45 mm (102), dos arandelas M10 (112) y una tuerca de nylon M10 (117) en el marco base (1).
- (f) Monte la polea de la correa (56) como se muestra en la imagen „Núm. 12“ con un tornillo allen M10x45 mm (102), dos arandelas M10 (112) y una tuerca de nylon M10 (117) en la pieza doble con forma de U (40).
- (g) Monte la polea de la correa (56) como se muestra en la imagen „Núm. 13“ con un tornillo allen M10x45 mm (102), dos arandelas M10 (112) y una tuerca de nylon M10 (117) en el marco base de la prensa para las piernas (2).
- (h) Monte la polea de la correa (56) y ambos rodamientos pequeños (89) como se muestra en la imagen „número 14“ con un tornillo allen M10x70 mm (100), dos arandelas M10 (112) y una tuerca de nylon M10 (117) en el soporte inferior de la prensa para las piernas (19).
- (i) Monte la polea de la correa (56) como se muestra en la imagen „Núm. 15“ con un tornillo allen M10x45 mm (102), dos arandelas M10 (112) y una tuerca de nylon M10 (117) en el marco vertical trasero de la prensa para las piernas (24).
- (j) Fije el extremo del tornillo del cable inferior (69) con un mosquetón (58), una cadena corta (63), tornillo allen M8x40 mm (107), dos arandelas M8 (114) y una tuerca de nylon (118) al marco del soporte del asiento de la prensa para las piernas (22).
- (k) Fije el tubo inferior (16) y la correa (74) al otro extremo del cable inferior (69) con una cadena larga (62) y dos mosquetones (58).

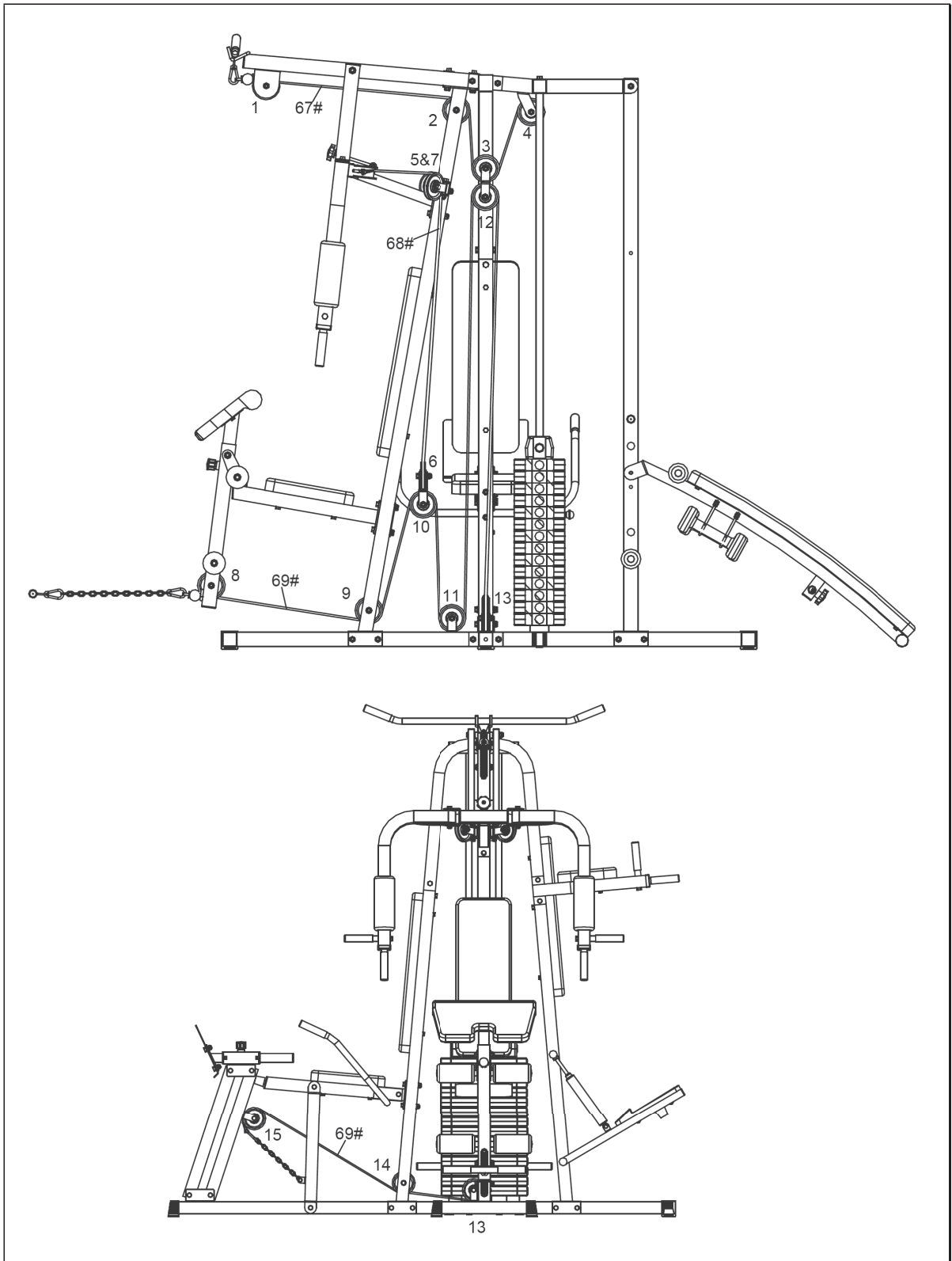

## CALENTAMIENTO ANTES DEL ENTRENAMIENTO

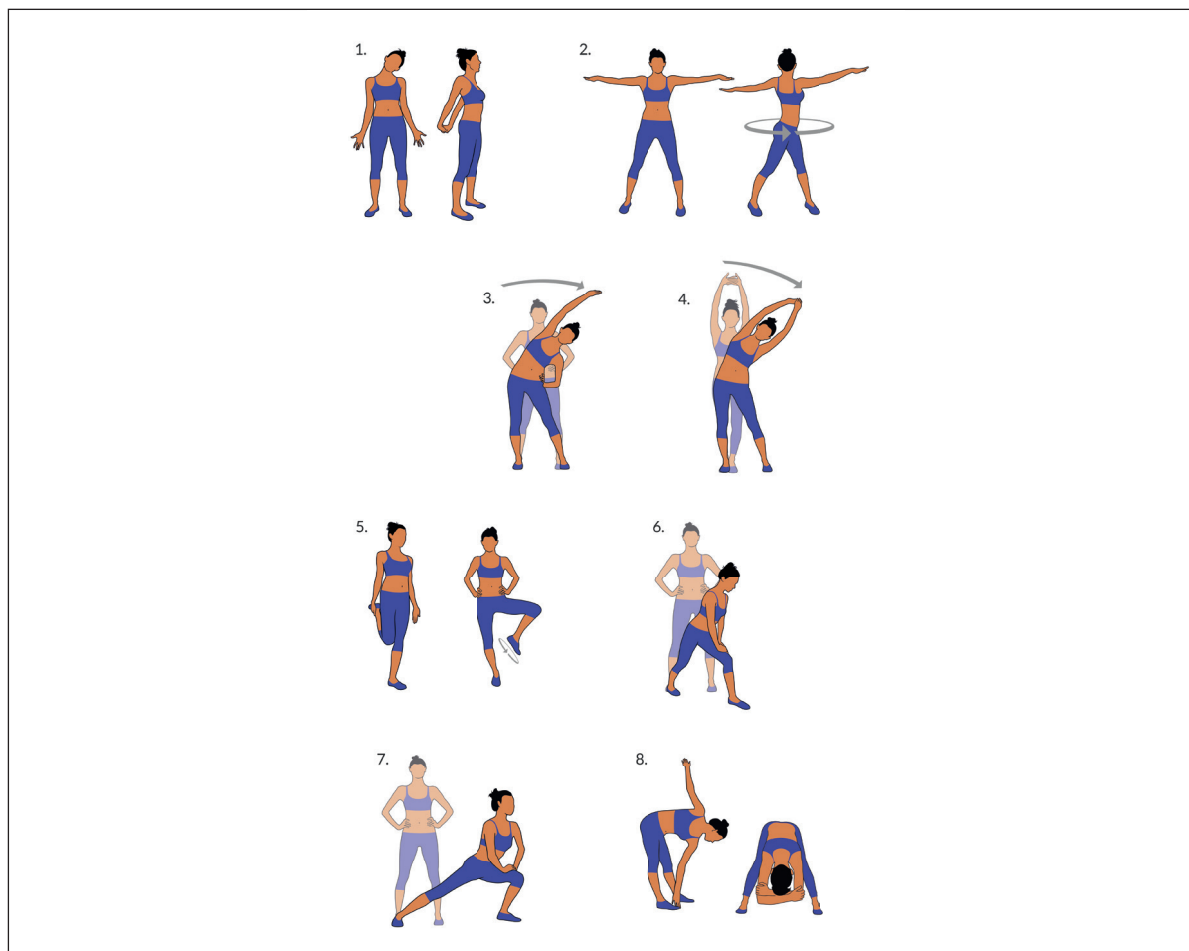

Realice los siguientes ejercicios de calentamiento antes de cada entrenamiento. Así movilizará las articulaciones y activará la musculatura.

Si siente molestias o dolor al realizar alguno de los movimientos, obvie dicho ejercicio y planifique un entrenamiento de calentamiento específico con su médico o entrenador.

Cada movimiento debe realizarse varias veces (a derecha e izquierda) para que pueda comenzar de manera relajada en el entrenamiento de cardio.

### Tómese unos 5 minutos de tiempo para las siguientes rutinas de entrenamiento de Klarfit.

1. Inclíne la cabeza lateralmente, moviéndola despacio de derecha a izquierda. Además, movilice los hombros (movimiento circular y contracción de los hombros).
2. Gire la cadera con los brazos extendidos. Los pies no están fijos al suelo (las articulaciones del pie acompañan la torsión del cuerpo).
3. Doble la cadera con un brazo extendido hacia arriba. Manténgase en esa posición unos segundos para cada lado.
4. Flexione la cadera con ambos brazos unidos hacia arriba. Manténgase también en esta posición para que el ejercicio sea un poco más intenso, ya que el segundo brazo participa.
5. Colóquese sobre una pierna y agarre el empeine con la mano. Aquí moviliza la articulación del pie y estira ligeramente los muslos. Sosténgase igualmente para mantener el equilibrio. Manténgase sobre una pierna y gire el pie en círculos en ambas direcciones.
6. Coloque una pierna adelante y apóyese con el tronco en el muslo. Aquí moviliza, además de las articulaciones de la rodilla y el pie, la musculatura interior de la pantorrilla.
7. Repita el ejercicio del punto 6 con la diferencia de que ahora debe dar un paso mayor hacia adelante. El movimiento será más intenso.
8. Inclínese con las piernas extendidas hacia adelante y toque alternativamente con la mano el pie contrario. Para finalizar, déjese caer hacia abajo de manera relajada.





**Chère cliente, cher client,**

Toutes nos félicitations pour l'acquisition de ce nouvel appareil. Veuillez lire attentivement et respecter les instructions de ce mode d'emploi afin d'éviter d'éventuels dommages. Le fabricant ne saurait être tenu pour responsable des dommages dus au non-respect des consignes de sécurité et à la mauvaise utilisation de l'appareil. Scannez le QR-Code pour accéder à la dernière version du mode d'emploi et à d'autres informations concernant le produit.

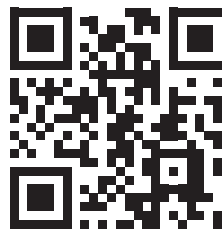

---

**SOMMAIRE**

---

Consignes de sécurité 74  
Aperçu des pièces détachées 75  
Assemblage 79  
Installation des câbles 90  
Échauffement avant l'entraînement 93

---

**FABRICANT ET IMPORTATEUR (UK)**

---

**Fabricant :**

Chal-Tec GmbH, Wallstraße 16, 10179 Berlin, Allemagne.

**Importateur pour la Grande Bretagne :**

Berlin Brands Group UK Limited  
PO Box 42  
272 Kensington High Street  
London, W8 6ND  
United Kingdom

---

**ENTRETIEN ET MAINTENANCE**

---

**Remarque :** comme pour tous les appareils d'exercice comprenant des pièces mécaniques mobiles, il peut arriver que les vis de ce produit se desserrent en raison d'une utilisation fréquente. Nous recommandons donc de les contrôler régulièrement et, si nécessaire, de les serrer avec une clé appropriée. Nettoyez régulièrement votre appareil avec un chiffon humide pour en retirer la sueur et la poussière.

- Nettoyez régulièrement l'appareil avec un chiffon propre pour conserver un aspect propre.
- L'utilisation de l'appareil en toute sécurité ne peut être garantie que si l'absence de dommages et le niveau d'usure sont régulièrement contrôlés (par exemple sur les poignées, les repose-pieds, la selle, etc.). Il est essentiel de remplacer les pièces endommagées de l'appareil et de réutiliser l'appareil seulement après réparation.
- Vérifiez régulièrement que les vis et les écrous sont correctement fixés.
- Lubrifiez les pièces mobiles régulièrement.

## CONSIGNES DE SÉCURITÉ



















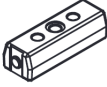

















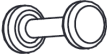





Lisez attentivement le mode d'emploi avant d'utiliser l'appareil et conservez-le pour référence ultérieure. Les caractéristiques du produit peuvent différer légèrement des illustrations. Le fabricant est susceptible d'effectuer des modifications sans préavis.

- Conservez le mode d'emploi en lieu sûr afin de pouvoir vous y référer à tout moment.
- Assemblez l'appareil uniquement après avoir lu entièrement ce mode d'emploi. La sécurité et l'efficacité de l'appareil ne peuvent être garanties que si l'appareil a été correctement monté, entretenu et utilisé. Il est de votre responsabilité de vous assurer que tous les utilisateurs de l'appareil sont informés des avertissements et des précautions d'utilisation.
- L'appareil doit être placé sur une surface stable et plane pour pouvoir l'utiliser en toute sécurité. Protégez le sol avec un tapis. N'utilisez pas l'appareil dans des environnements humides tels que des piscines, etc. La distance de sécurité autour de l'appareil doit être d'au moins 0,6 mètre.
- Avant de suivre les programmes d'exercices, consultez un médecin pour déterminer si vous avez des problèmes physiques ou de santé qui pourraient mettre en danger votre santé et votre sécurité en utilisant l'appareil ou vous empêcher de l'utiliser correctement. Les conseils de votre médecin sont essentiels si vous prenez des médicaments qui affectent votre rythme cardiaque, votre tension artérielle ou votre taux de cholestérol.
- Soyez attentif aux signaux de votre corps. Un exercice inapproprié ou excessif peut être nocif. Arrêtez de faire de l'exercice si l'un des symptômes suivants se manifeste : douleur, sensation d'oppression dans la poitrine, rythme cardiaque irrégulier, essoufflement extrême, vertiges ou nausée. Si vous rencontrez l'une de ces conditions, consultez immédiatement un médecin avant de continuer à vous entraîner.
- Ne faites pas d'exercice directement après les repas.
- L'appareil ne doit être assemblé que par des adultes. Tenez les enfants et les animaux domestiques éloignés de l'appareil.
- L'appareil ne doit être utilisé qu'à domicile.
- L'appareil ne convient pas à un usage thérapeutique. Il ne peut être utilisé que pour les exercices indiqués dans le manuel.
- Portez des vêtements et des chaussures d'entraînement appropriés lors de l'utilisation de l'appareil. Évitez les vêtements amples car ils pourraient se coincer dans l'appareil de même que les vêtements qui pourraient restreindre votre liberté de mouvement.
- Gardez votre dos droit pendant l'entraînement.
- Avant chaque utilisation, vérifiez que les poignées, la selle et les écrous et boulons sont bien serrés.
- Faites attention à la position maximale réglable des pièces de l'appareil et n'allez pas au-delà de la marque „Stop“, car cela créerait un risque.
- Utilisez l'appareil uniquement comme indiqué. Si vous remarquez des pièces défectueuses lors du montage ou de l'inspection, ou si vous entendez des bruits étranges provenant de l'appareil en cours d'utilisation, cessez de l'utiliser immédiatement. N'utilisez pas l'appareil tant que le problème n'est pas résolu.
- Soyez prudent lorsque vous soulevez ou déplacez l'appareil pour ne pas vous blesser au dos. Utilisez toujours des techniques de levage qui préservent le dos et demandez l'aide d'une autre personne si nécessaire.
- Tous les équipements mobiles (pédales, poignées, selles, etc.) doivent être entretenus chaque semaine. Vérifiez-les avant chaque utilisation. Si quelque chose est cassé ou desserré, réparez ou fixez la pièce correspondante immédiatement. Ne poursuivez pas l'utilisation de l'appareil tant que vous n'avez pas restauré le bon état initial.
- Soyez attentif au système de roue libre, sa défaillance représente un risque sérieux.
- Tenez le câble d'alimentation à l'écart des sources de chaleur.
- N'insérez aucun objet dans les ouvertures de l'appareil.
- Éteignez l'appareil et débranchez le câble d'alimentation avant de déplacer ou de nettoyer l'appareil. Pour le nettoyage, frottez les surfaces avec un nettoyeur doux et un chiffon humide. N'utilisez jamais de solvants.
- N'utilisez pas l'appareil dans des endroits non tempérés, tels qu'un garage, une véranda, une salle de bain, un abri de voiture ou à l'extérieur.
- N'utilisez l'appareil que de la manière décrite dans le mode d'emploi.
- Une réparation incorrecte et des modifications structurelles (telles que le retrait ou le remplacement de pièces d'origine) peuvent mettre en danger l'utilisateur de l'appareil.
- Le volant d'inertie devient très chaud pendant l'utilisation.
- Activez le verrouillage des touches si vous n'utilisez pas l'appareil.
- Les enfants à partir de 8 ans et les personnes handicapées mentales et physiques ne peuvent utiliser l'appareil que s'ils ont été familiarisés avec les fonctions et les consignes de sécurité par un responsable responsable.
- Assurez-vous que les enfants ne jouent pas avec l'appareil.
- Avant utilisation, vérifiez la tension sur la plaque signalétique de l'appareil. Ne branchez l'appareil qu'à des prises correspondant à la tension de l'appareil.

**Remarque :** poids maximal de l'utilisateur : 120 kg.





























## APERÇU DES PIÈCES DÉTACHÉES

1 	2 	3 	4 	5 
6 	7 	8 	9 	10 
11 	12 	13 	14 	15 
16 	17 	18 	19 	20 
21 	22 	23 	24 	25 
26 	27 	28 	29 	30 
31 	32 	33 	34 	35 
36 	37 	38 	39 	40 
41 	42 	43 	44 	45 

46 	47 	48 	49 	50 
51 	52 	53 	54 	55 
56 	57 	58 	59 	60 
61 	62 	63 	64 	65 
66 	67 	68 	69 	70 
71 	72 	73 	74 	75 
76 	77 	78 	79 	80 
81 	82 	83 	84 	85 
86 	87 	88 	89 	90 

N°	Description	Qté	N°	Description	Qté
1	Cadre de base	1	46	Coussin du dossier	3
2	Presse à jambes du cadre de base	1	47	Coussin d'assise	2
3	Cadre de base	1	48	Coussin d'accoudoir	1
4	Tube de guidage des poids	4	49	Coussin de banc	1
5	Piles de poids	1	50	Coussin d'accoudoir	2
6	Cadres de support	1	51	Coussin de levier de la presse à jambes	4
7	Barre de résistance	1	52	Tubes de mousse pour les accoudoirs	2
8	Extension des jambes	1	53	Tubes de mousse	4
9	Cadre du siège	1	54	Disque de poids supérieur	1
10	Cadre des accoudoirs	1	55	Disques de poids	14
11	Bras papillon droit	1	56	Poulies	15
12	Bras papillon gauche	1	57	Goupille de sélection de poids	1
13	Barre de la presse	1	58	Mousquetons	4
14	Grand tube de mousse	2	59	Amortisseur (long)	1
15	Tube des poignées	4	60	Amortisseurs (court)	2
16	Tube inférieur	1	61	Vis de blocage	1
17	Barre de traction	1	62	Grande chaîne	1
18	Traverse supérieure	1	63	Chaîne courte	1
19	Support inférieur (presse à jambes)	1	64	Vis de blocage	1
20	Support supérieur (presse à jambes)	1	65	Manchon à huile	2
21	Cadre du siège (presse à jambes)	1	66	Goupille de sécurité	1
22	Cadre de support de siège (presse à jambes)	1	67	Câble supérieur	1
23	Montant vertical avant de la presse à jambes	1	68	Câble papillon	1
24	Montant vertical arrière de la presse à jambes	1	69	Câble inférieur	1
25	Cadre de connexion de la presse à jambes	1	70	Bouton de réglage	2
26	Cadre de réglage de la plaque de la presse	1	71	Rondelle	1
27	Plaque de la presse à jambes	1	72	Anneau en plastique	1
28	Main courante de la presse à jambes	1	73	Goupille	1
29	Cadre du banc	1	74	Sangle	1
30	Cadre des pédales	2	75	Haltère court	2
31	Cadre de support inférieur	1	76	Rondelles en caoutchouc	2
32	Cadre de support supérieur	1	77	Poignées	18
33	Arceau de droite	1	78	Embout carré 50 mm	7
34	Arceau de gauche	1	79	Embout	1
35	Cadre vertical arrière	1	80	Bouchon central carré	4
36	Tube de poignée du banc	1	81	Bouchon carré 50 mm	8
37	Tube en mousse court	1	82	Bouchon carré 38 mm	2
38	Tube de prise long	1	83	Embout carré 30 x 60 mm	2
39	Double U dos à dos	1	84	Embout carré 25x50 mm	2
40	Double U	1	85	Capuchon de pédale (grand)	4
41	U simple	2	86	Embout rond 25 mm	8
42	Plaque	1	87	Embout carré central	2
43	Crochet pour haltère court	4	88	Pédales	2
44	Boulons (en forme de pipe)	1	89	Bagues (petites)	8
45	Cylindre	2	90	Bagues en plastique	4

## Petits éléments

91 	92 	93 	94 	95 
96 	97 	98 	99 	100 
101 	102 	103 	104 	105 
106 	107 	108 	109 	110 
111 	112 	113 	114 	115 
116 	117 	118 		

N°	Description	Qté	N°	Description	Qté
91	Embout rond 38 mm	2	105	Vis M10x20 mm	4
92	Cache en plastique	2	106	Vis Allen M8x65 mm	16
93	Capuchon carré 38 mm	1	107	Vis Allen M8x40 mm	4
94	Bouchon tampon	2	108	Vis Allen M8x16mm	10
95	Cache de vis	4	109	Vis M6x40 mm	4
96	Vis Allen M12x150 mm	1	110	Rondelle M12	4
97	Vis Allen M12x75 mm	1	111	Rondelle Ø30xØ10	1
98	Vis Allen M10x85 mm	2	112	Rondelle M10	111
99	Vis Allen M10 x 75 mm	6	113	Rondelle Ø25xØ8	4
100	Vis Allen M10x70 mm	29	114	Rondelle M8	32
101	Vis Allen M10x65 mm	2	115	Rondelle M6	4
102	Vis Allen M10x45 mm	11	116	Ecrou en nylon M12	2
103	Vis Allen M10x25 mm	2	117	Ecrou en nylon M10	52
104	Vis Allen M10x20 mm	7	118	Ecrou en nylon M8	6

## ASSEMBLAGE

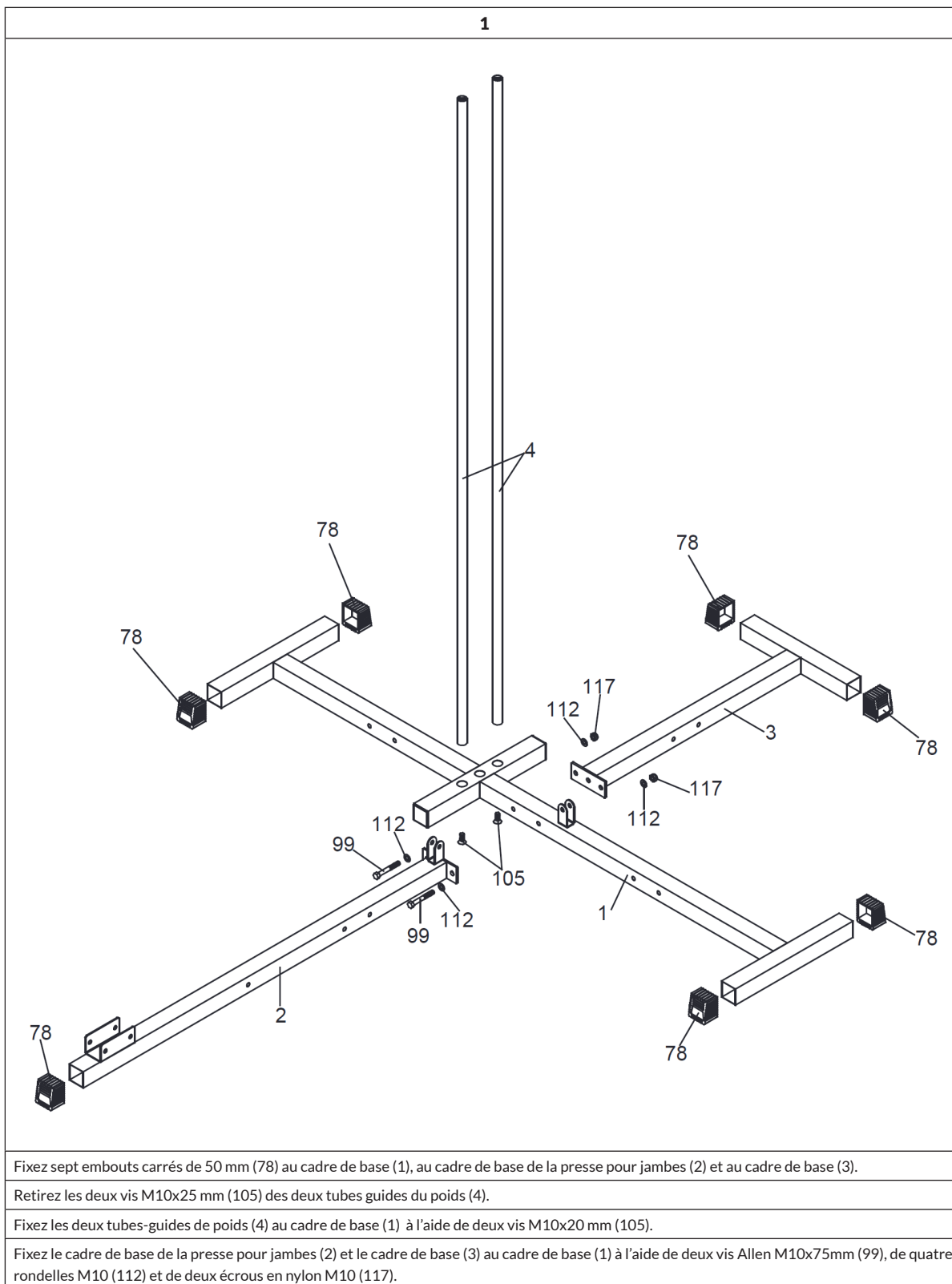

Fixez sept embouts carrés de 50 mm (78) au cadre de base (1), au cadre de base de la presse pour jambes (2) et au cadre de base (3).

Retirez les deux vis M10x25 mm (105) des deux tubes guides du poids (4).

Fixez les deux tubes-guides de poids (4) au cadre de base (1) à l'aide de deux vis M10x20 mm (105).

Fixez le cadre de base de la presse pour jambes (2) et le cadre de base (3) au cadre de base (1) à l'aide de deux vis Allen M10x75mm (99), de quatre rondelles M10 (112) et de deux écrous en nylon M10 (117).

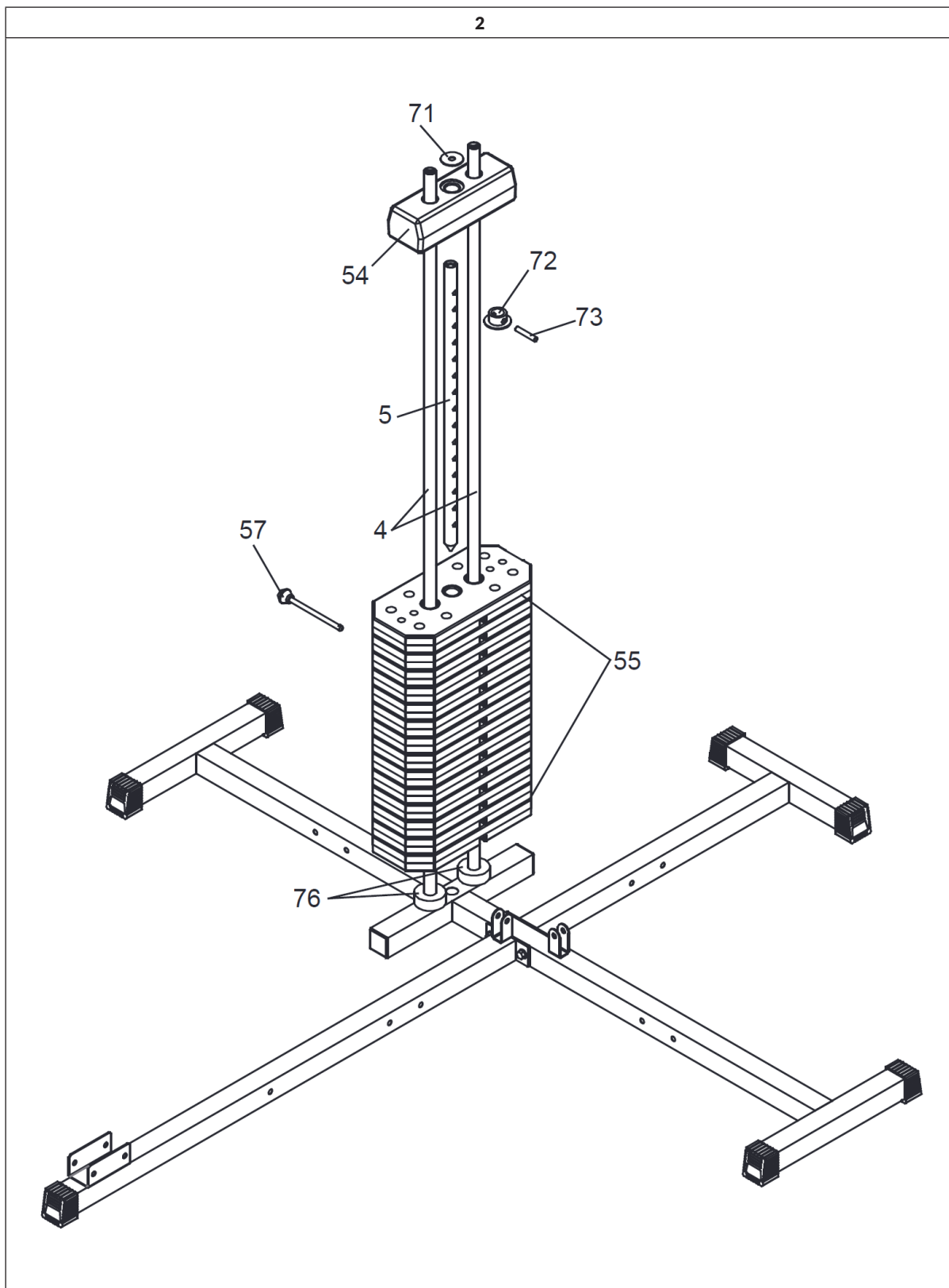

Faites glisser les deux rondelles en caoutchouc (76) sur le tube de guidage (4).

Faites glisser les 14 plaques de poids (55) sur le tube de guidage (4).

Faites glisser la bague en plastique (72) le long de la pile de poids (5) et fixez-la au trou supérieur avec la goupille (73).

Insérez la pile de poids (5) dans le trou des disques de poids (55).

Faites glisser le disque de poids supérieur (54) sur le tube de guidage (4) et insérez la goupille de sélection de poids (57) dans le trou correspondant au poids souhaité.

Placez la rondelle (71) sur le disque de poids supérieur (54).



3

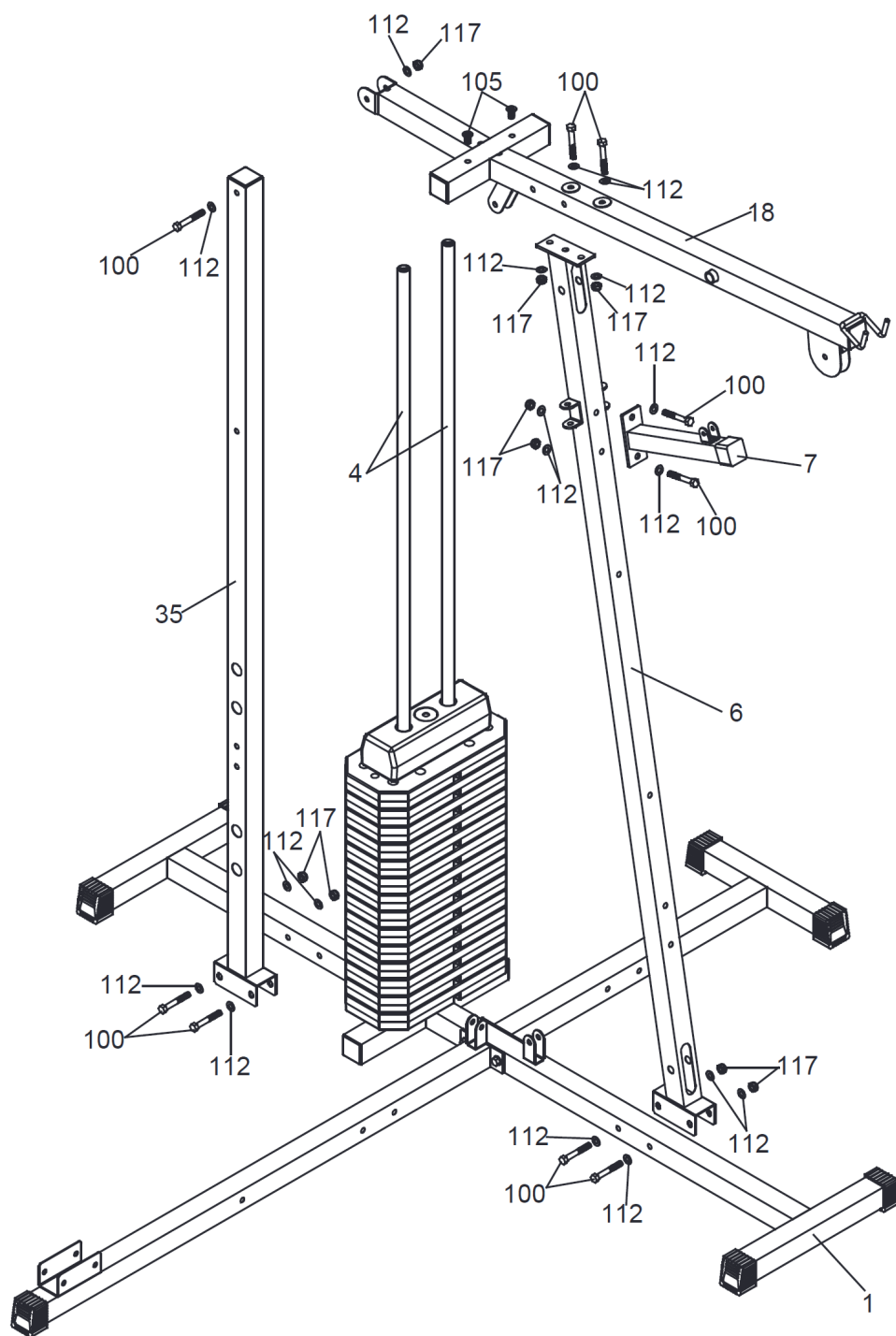

Fixez le cadre de support (6) et le montant arrière de cadre (35) au cadre de base (1) à l'aide de quatre vis Allen M10x70 mm (100), de huit rondelles M10 (112) et de quatre écrous en nylon M10 (117).

Retirez les deux Vis M10x25mm (105) des deux tubes guides (4).

Fixez la traverse supérieure (18) aux deux tubes de guidage (4) à l'aide de deux vis M10x25 mm (105).

Fixez la barre transversale supérieure (18) au cadre de support (6) et au cadre du montant arrière (35) à l'aide de trois vis Allen M10x70 mm (100), de six rondelles M10 (112) et de trois écrous en nylon M10 (117).

Attachez la barre de résistance (7) au cadre de support (6) à l'aide de deux vis Allen M10x70 mm (100), de quatre rondelles M10 (112) et de deux écrous en nylon M10 (117).

4

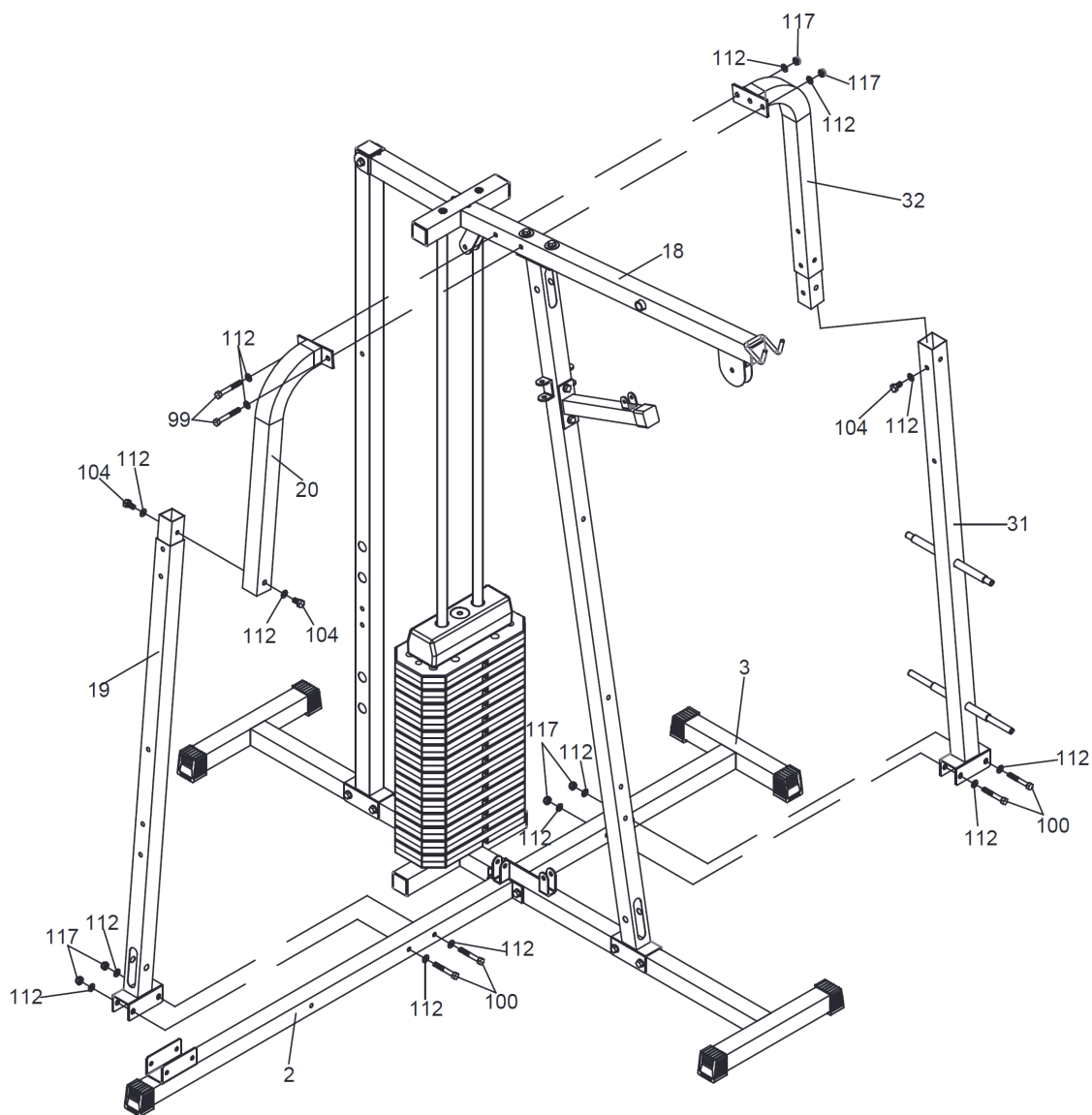

Fixez le support inférieur (19) de la presse à jambes à l'aide de deux vis Allen M10x70mm (100), de quatre rondelles M10 (112) et de deux écrous en nylon M10 (117) au cadre de base de la presse à jambes (2).

Fixez le cadre de support inférieur (31) avec deux vis Allen M10x70 mm (100), quatre rondelles M10 (112) et deux écrous en nylon M10 (117) sur le cadre de base (3).

Fixez le support supérieur (20) de la presse à jambes au cadre de support inférieur (19) à l'aide de deux vis Allen M10x20 mm (104) et de deux rondelles M10 (112).

Fixez le cadre de support supérieur (32) au cadre de support inférieur (31) à l'aide d'une vis hexagonale M10x20mm (104) et d'une rondelle M10 (112).

Fixez le support supérieur de la presse à jambes (20) et le cadre de soutien supérieur (32) avec deux vis Allen M10x75 mm (99), quatre rondelles M10 (112) et deux écrous en nylon M10 (117) à la traverse supérieure (18).

5

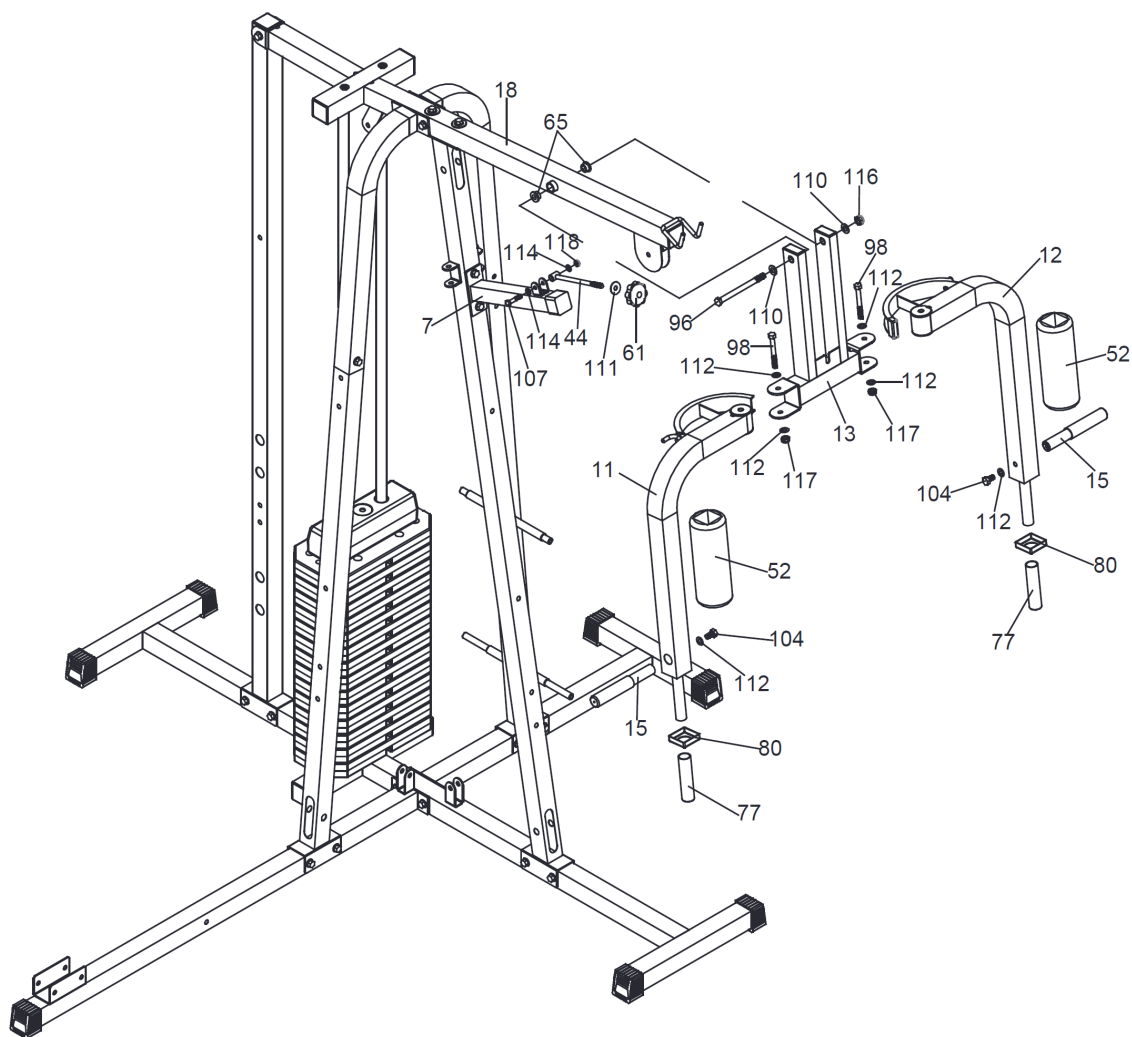

**Remarque :** le manchon à huile (65) est préinstallé sur la traverse supérieure (18).

Fixez la barre de la presse (13) à la barre transversale supérieure (18) à l'aide d'une vis Allen M12x150mm (96), de deux rondelles M12 (110) et d'un écrou en nylon M12 (116).

Fixez les bras papillon gauche et droit (11 et 12) à la barre de la presse (13) à l'aide de deux vis Allen M10x85mm (98), de quatre rondelles M10 (112) et de deux écrous en nylon M10 (117).

Glissez deux tubes en mousse (52) sur les bras papillon gauche et droit (11 et 12).

Retirez les deux vis Allen M10x20mm (104) et les deux rondelles M10 (112) des deux tubes de poignée (15).

Fixez les deux tubes de poignée (15) aux bras papillon gauche et droit (11 et 12) à l'aide de deux vis Allen M10x20mm (104) et de deux rondelles M10 (112).

Faites glisser les deux bouchons carrés (80) et les deux poignées (77) sur les bras papillon gauche et droit (11 et 12).

Fixez le boulon (44) avec une vis Allen M8x40 mm (107), deux rondelles M8 (114) et un écrou M8 (118) sur la barre de résistance (7).

Faites glisser la rondelle (111) et la vis de réglage (61) sur le boulon (44).

6

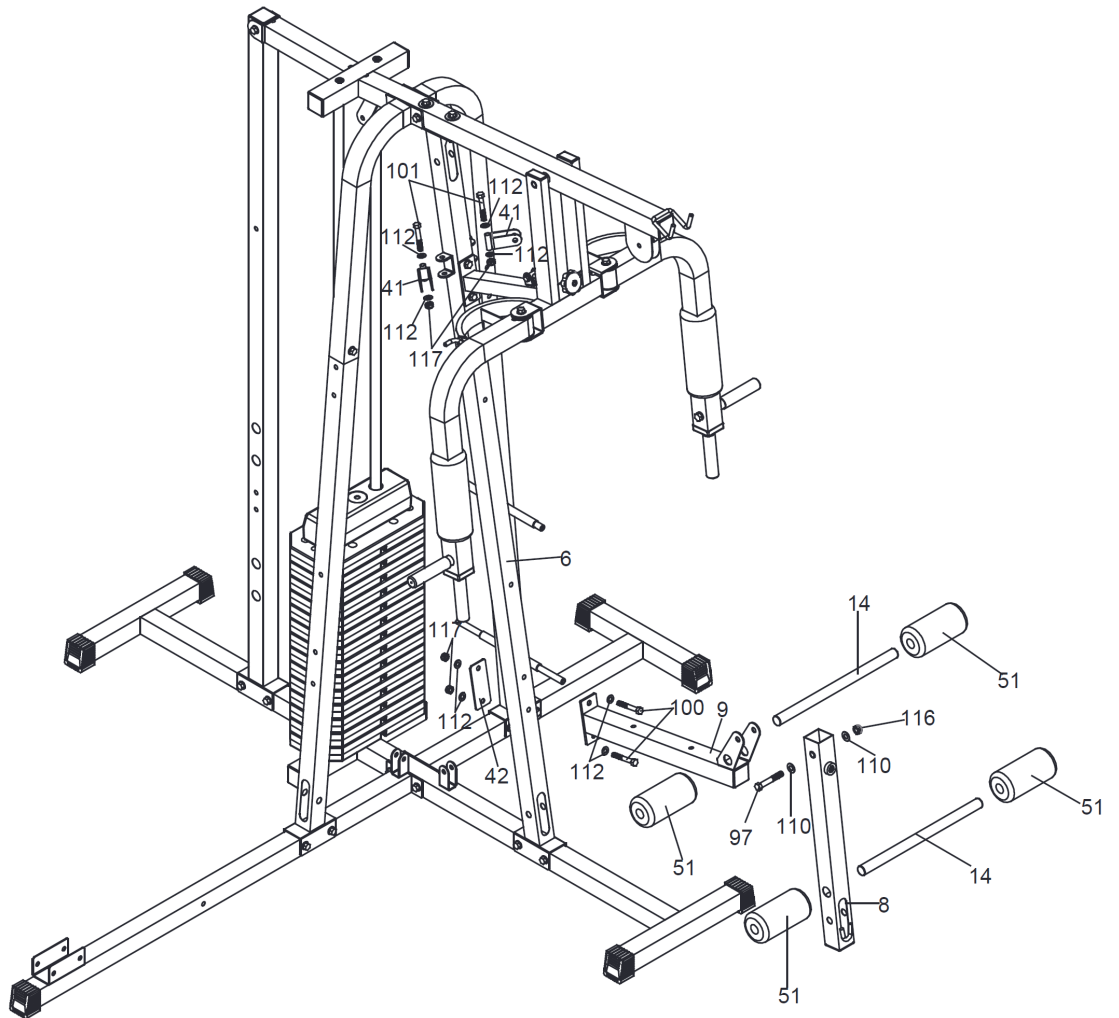

Fixez le cadre du siège (9) et la plaque (42) au cadre support (6) à l'aide de deux vis Allen M10x70mm (100), de quatre rondelles M10 (112) et de deux écrous en nylon M10 (117).

Fixez le poussoir de la presse à jambes (8) au cadre du siège (9) à l'aide d'une vis Allen M12x75mm (97), de deux rondelles M12 (110) et d'un écrou en nylon M12 (116).

Insérez les deux longs tubes en mousse (14) dans le poussoir de la presse à jambes (8) et le cadre de siège (9).

Glissez les coussinets du poussoir à jambes (51) sur les longs tubes en mousse (14).

Fixez le joint en U (41) au cadre de support (6) à l'aide de deux vis Allen d'assemblage M10x65mm (101), de quatre rondelles M10 (112) et de deux écrous en nylon M10 (117)

7

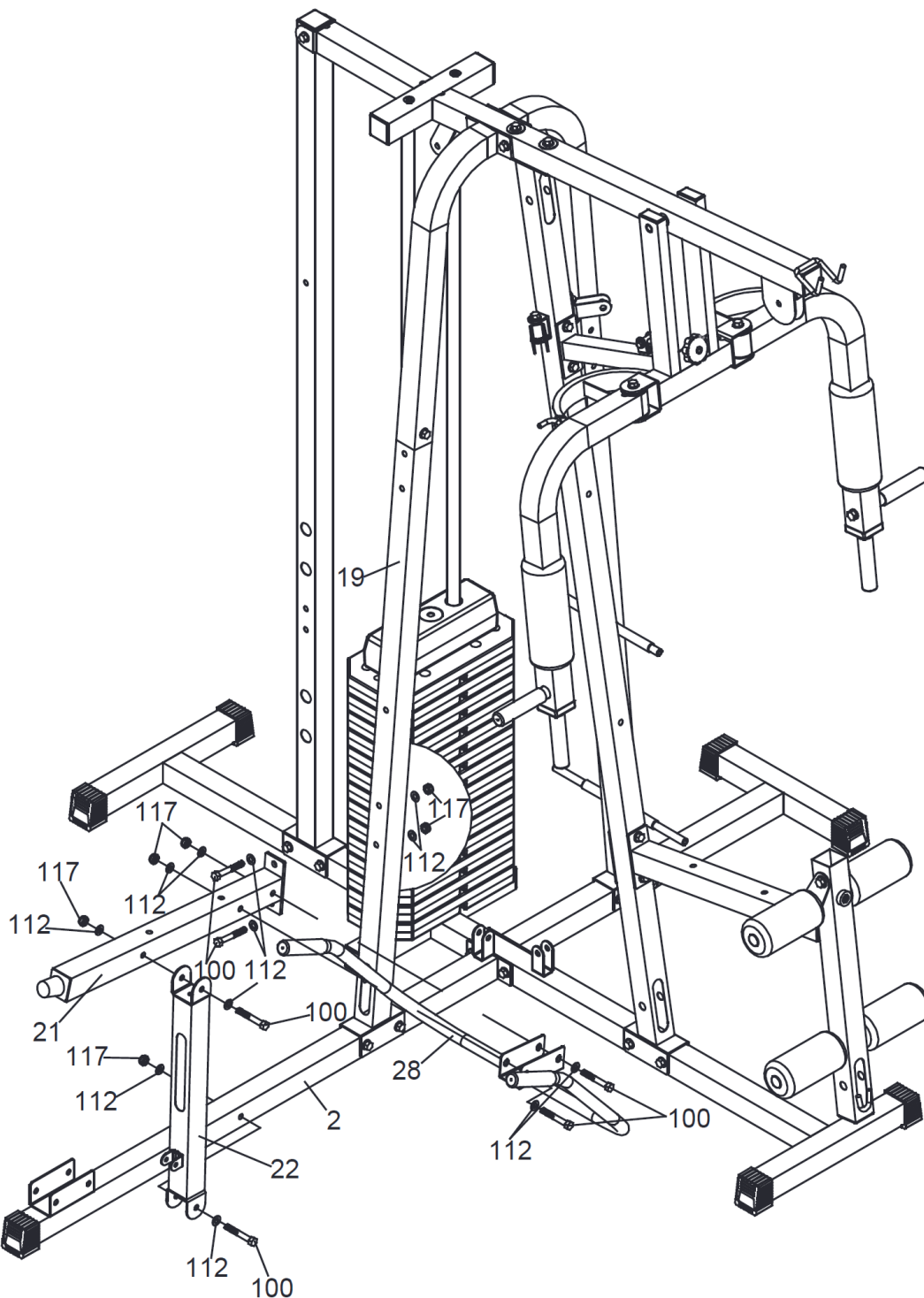

Fixez le cadre de support de siège (22) de la presse à jambes à l'aide d'une vis Allen M10x70 mm (100), de deux rondelles M10 (112) et d'un écrou en nylon M10 (117) au cadre de base de la presse à jambes (2).

Fixez le cadre du siège (21) à la jambe inférieure (19) et au cadre de support du support de jambe (22) à l'aide de trois vis Allen M10x70 mm (100), de six rondelles M10 (112) et de trois écrous en nylon M10 (117).

Fixez la main courante (28) au cadre du siège (21) à l'aide de deux vis Allen M10x70mm (100), de quatre rondelles M10 (112) et de deux écrous en nylon M10 (117).

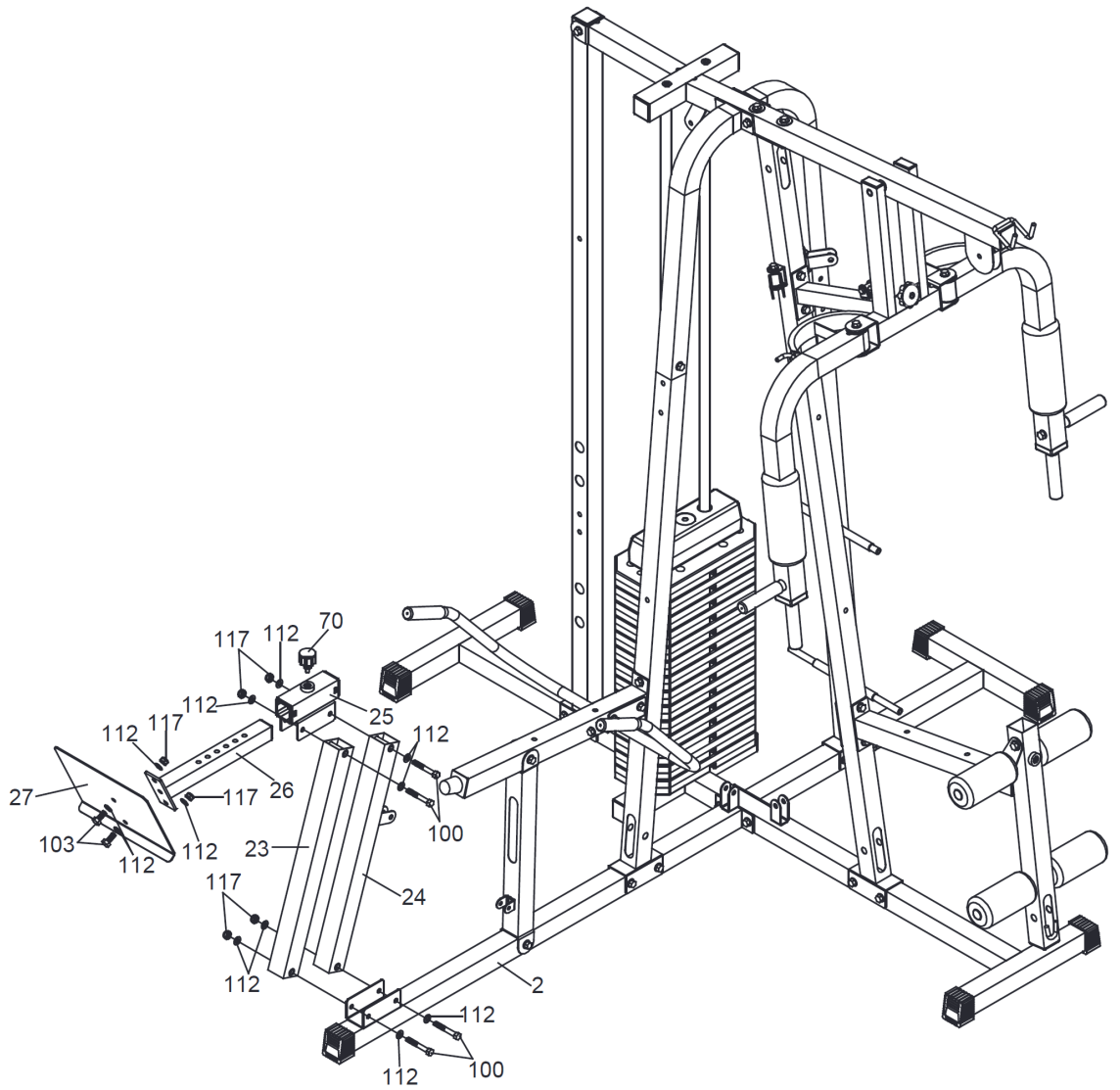

Fixez le montant avant du cadre (23) et le montant arrière (24) au cadre de base la presse à jambes (2) à l'aide de deux Vis Allen M10x70mm (100), de quatre rondelles M10 (112) et de deux écrous en nylon M10 (117).

Fixez le cadre de liaison (25) avec deux vis Allen M10x70 mm (100), quatre rondelles M10 (112) et deux écrous en nylon M10 (117) à l'avant (23) et à l'arrière du montant vertical (24).

Fixez la plaque de presse à jambes (27) au cadre de réglage de la presse à jambes (26) à l'aide de deux vis Allen M10x25mm (103), de quatre rondelles M10 (112) et de deux écrous en nylon M10 (117).

Insérez le cadre de réglage (26) dans le cadre de liaison de la presse à jambes (25) et fixez le bouton de réglage (70).

9

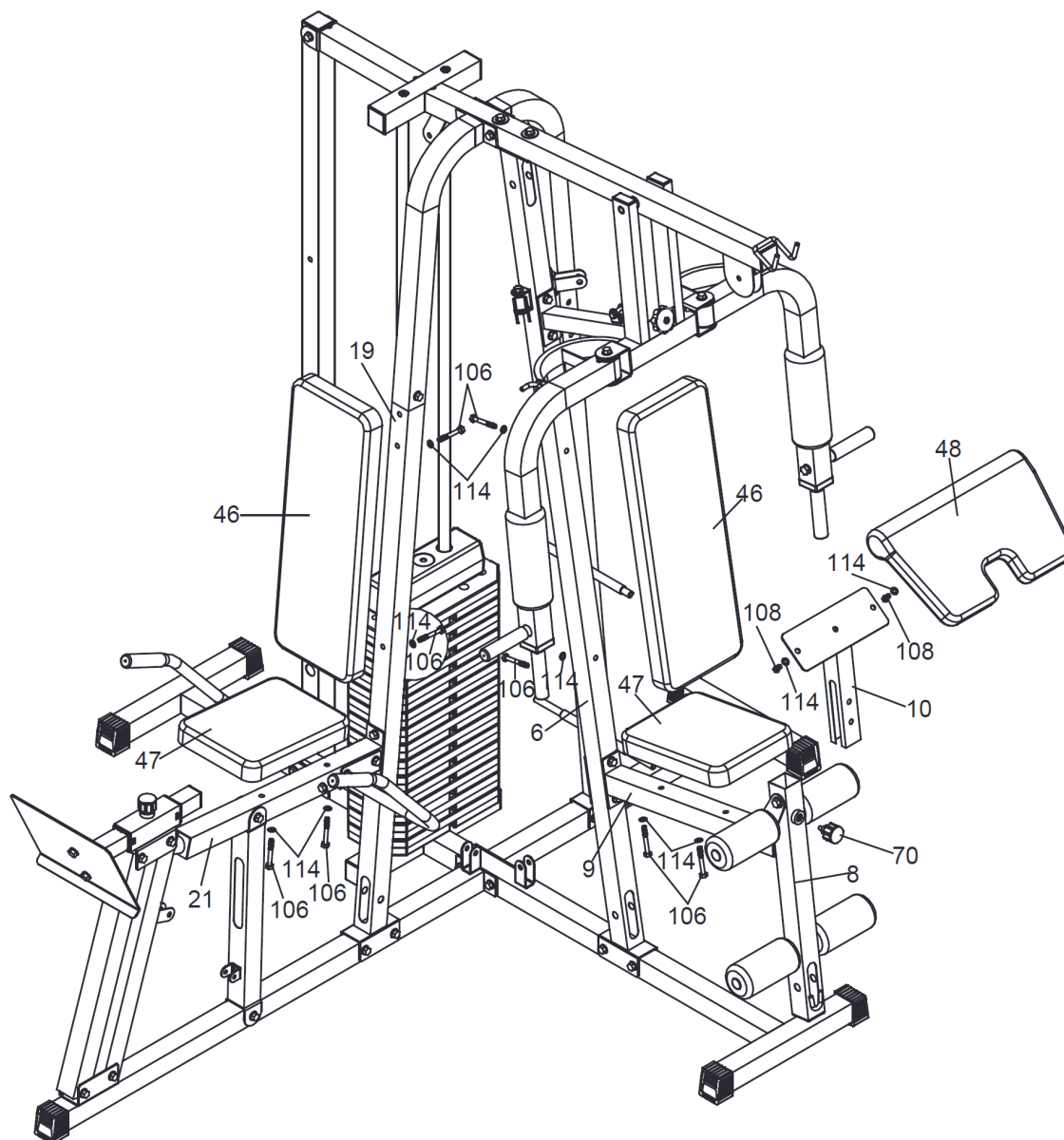

Fixez les deux coussins de dossier (46) au cadre de support (6) et au support inférieur (19) à l'aide de quatre vis Allen M8x65mm (106) et de quatre rondelles M8 (114).

Fixez les deux coussins de siège (47) au cadre de siège (9) et au cadre de siège de la presse à jambes (21) à l'aide de quatre vis Allen M8x65mm (106) et de quatre rondelles M8 (114).

Fixez le coussin d'accoudoir (48) au cadre d'accoudoir (10) à l'aide de deux vis Allen M8x16mm (108) et de deux rondelles M8 (114).

Insérez le cadre d'accoudoir (10) dans le poussoir de la presse à jambes (8) et fixez-le avec le bouton de réglage (70).

10

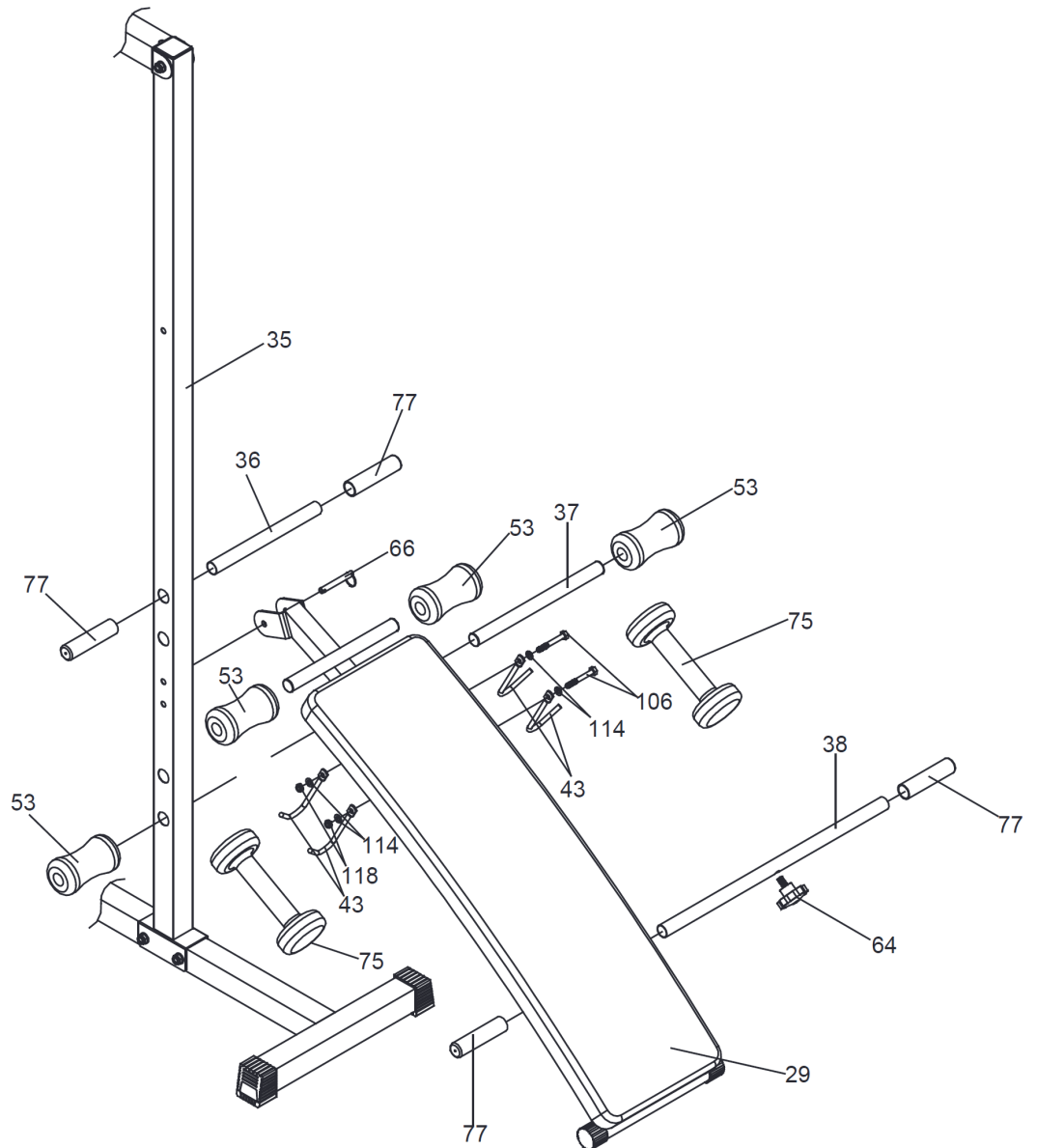

Fixez les quatre crochets pour haltères courts (43) au cadre du banc (29) à l'aide de deux vis Allen M8x65mm (106), de quatre rondelles M8 (114) et de deux écrous en nylon M8 (118). Placez les deux haltères (75) sur les crochets.

Insérez le long tube de poignée (38) dans le cadre du banc (29) et serrez la vis de blocage (64). Faites glisser les deux poignées (77) sur le tube de poignée (38).

Fixez le cadre du banc (29) au montant arrière du cadre (35) à l'aide de la goupille de sécurité (66).

Glissez le tube de poignée de banc (36) dans le montant arrière du cadre (35). Glissez les deux (77) sur le tube de la poignée du banc (36).

Insérez le tube de mousse court (37) dans le cadre du banc (29). Faites glisser les quatre tubes de mousse (53) sur le long tube (37) et le cadre du banc (29).



11

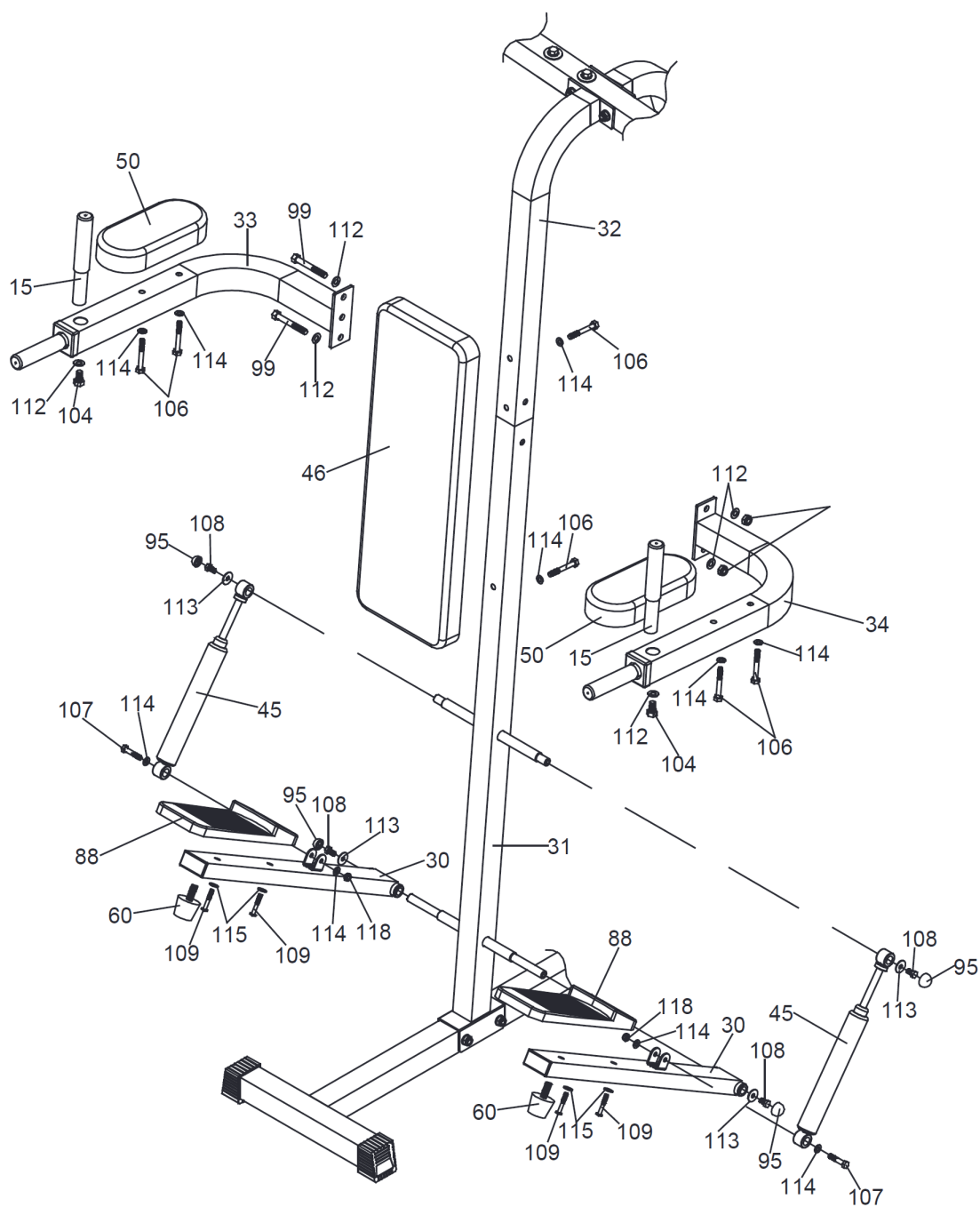

Fixez les pédales (88) au cadre de la pédale (30) à l'aide de quatre vis (109) et de quatre rondelles M6 (115). Fixez les deux amortisseurs (60) aux deux cadres de pédales (30). Fixez les deux cadres de pédales (30) avec deux vis Allen (108), deux rondelles (113) et deux caches de vis (95) sur le cadre de support inférieur (31).

Fixez les deux cylindres (45) au cadre de support inférieur (31) à l'aide de deux vis Allen (108), de deux rondelles (113) et de deux capuchons de vis (95). Attachez les deux cylindres (45) au cadre de la pédale (30) à l'aide de deux vis Allen (107), de quatre rondelles (114) et de deux écrous en nylon (118).

Fixez les arceaux droit et gauche (33 et 34) aux cadres de support inférieur (31) et supérieur (32) à l'aide de deux vis Allen (99), de quatre rondelles (112) et de deux écrous en nylon M10 (117). Fixez les tubes de poignée (15) à l'aide de deux vis Allen (104) et de deux rondelles (112) aux arceaux droit et gauche (33 et 34).

# INSTALLATION DES CÂBLES

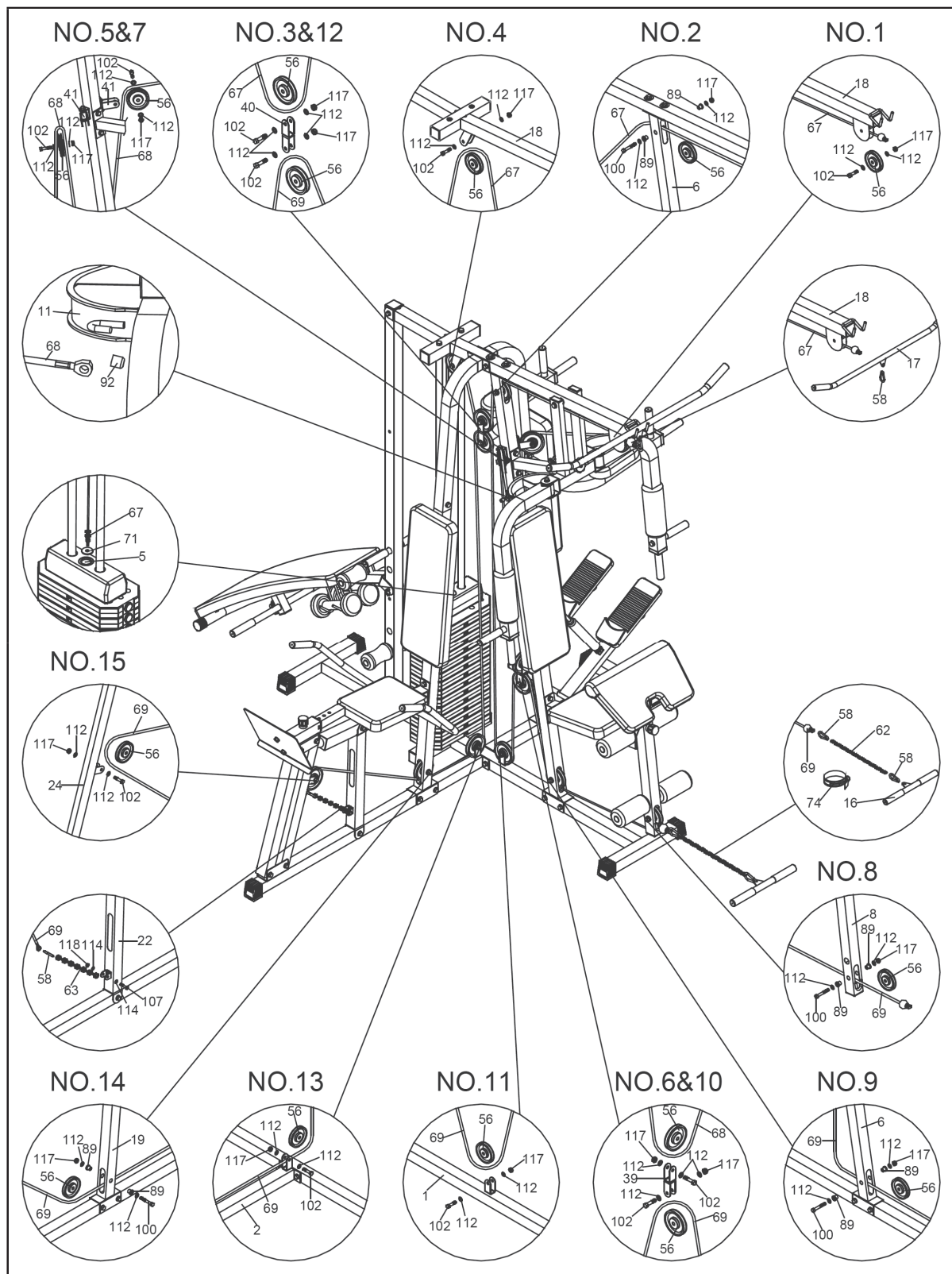

### Commencez par le câble supérieur (76)

- (a) Passez le câble supérieur (67), situé dans la gorge de la poulie (56), à travers la barre transversale supérieure (18).
- (b) Assemblez la poulie (56) comme indiqué sur la photo „N°1“ avec une vis Allen M10x45 mm (102), deux rondelles M10 (112) et un écrou en nylon M10 (117) sur la traverse supérieure (18).
- (c) Montez la poulie (56) et les deux bagues comme indiqué sur la photo „N°2“ avec une vis Allen M10x70 mm (100), deux rondelles M10 (112) et un écrou en nylon M10 (117) sur le cadre de support (6).
- (d) Assemblez la poulie (56) comme indiqué sur la photo „N°3“ avec une vis Allen M10x45 mm (102), deux rondelles M10 (112) et un écrou en nylon M10 (117) sur la traverse supérieure (18).
- (e) Fixez le boulon du câble supérieur (67) sur l'arbre de sélection (5) à l'aide d'une rondelle (71).
- (f) Montez la poulie (56) comme indiqué sur la photo „N°3“ avec une vis Allen M10x45 mm (102), deux rondelles M10 (112) et un écrou en nylon M10 (117) sur la pièce en U double (40).
- (g) Fixez la barre de traction (17) avec le mousqueton (58) à l'autre extrémité du câble supérieur (67).

### 2. Montage du câble papillon (68)

- (a) Fixez les deux extrémités du câble papillon (68) aux bras papillon droit et gauche (11 et 12) avec deux vis, puis fixez les caches en plastique (92).
- (b) Montez la poulie (56) comme indiqué sur les images „N°5 & 7“ à l'aide de deux vis Allen M10x45 mm (102), de quatre rondelles M10 (112) et de deux écrous en nylon M10 (117) sur chaque pièce en U (41).
- (c) Montez la poulie (56) comme indiqué sur la photo „N°6“ à l'aide d'une vis Allen M10x45 mm (102), de deux rondelles M10 (112) et d'un écrou en nylon M10 (117) sur le double raccord en U (39).

### 3. Montage du câble inférieur (69)

- (a) Passez le câble inférieur (69), situé dans la gorge de la poulie (56), à travers le poussoir de la presse à jambes (8).
- (b) Assemblez la poulie (56) et les deux petites douilles (89) comme indiqué sur la photo „N°8“ avec une vis Allen M10x70 mm (100), deux rondelles M10 (112) et un écrou en nylon M10 (117) sur le poussoir de la presse à jambes (8).
- (c) Montez la poulie (56) et les deux petites douilles (89) comme indiqué sur la photo „N°9“ avec une vis Allen M10x70 mm (100), deux rondelles M10 (112) et un écrou en nylon M10 (117) sur le cadre de support (6).
- (d) Montez la poulie (56) comme indiqué sur la photo „N°10“ avec une vis Allen M10x45 mm (102), deux rondelles M10 (112) et un écrou en nylon M10 (117) à l'arrière du double joint en U (39).
- (e) Montez la poulie (56) sur le cadre de base (1) à l'aide d'une vis Allen M10x45 mm (102), de deux rondelles M10 (112) et d'un écrou en nylon M10 (117), comme indiqué sur la photo „N°11“.
- (f) Assemblez la poulie (56) comme indiqué sur la photo „N°12“ avec une vis Allen M10x45 mm (102), deux rondelles M10 (112) et un écrou en nylon M10 (117) sur la pièce en U double (40).
- (g) Montez la poulie (56) sur le châssis de la presse à jambes (2) à l'aide d'une vis Allen M10x45 mm (102), de deux rondelles M10 (112) et d'un écrou en nylon M10 (117), comme indiqué sur la photo „N°13“.
- (h) Montez la poulie (56) et les deux petites douilles (89) comme indiqué sur la photo „N°14“ avec une vis Allen M10x70 mm (100), deux rondelles M10 (112) et un écrou en nylon M10 (117) sur la Appuyez sur la jambe inférieure de la jambe (19).
- (i) Assemblez la poulie (56) comme indiqué sur la photo „N°15“ avec la vis Allen M10x45 mm (102), deux rondelles M10 (112) et un écrou en nylon M10 (117) sur le montant vertical de la presse à jambe (24).
- (j) Fixez l'extrémité inférieure du câble (69) à l'aide d'un mousqueton (58), d'une chaîne courte (63), d'une vis Allen M8x40 mm (107), de deux rondelles M8 (114) et d'un écrou en nylon M8 (118).
- (k) Fixez le tube inférieur (16) et la sangle (74) à l'autre extrémité du câble inférieur (69) à l'aide d'une longue chaîne (62) et de deux mousquetons (58).

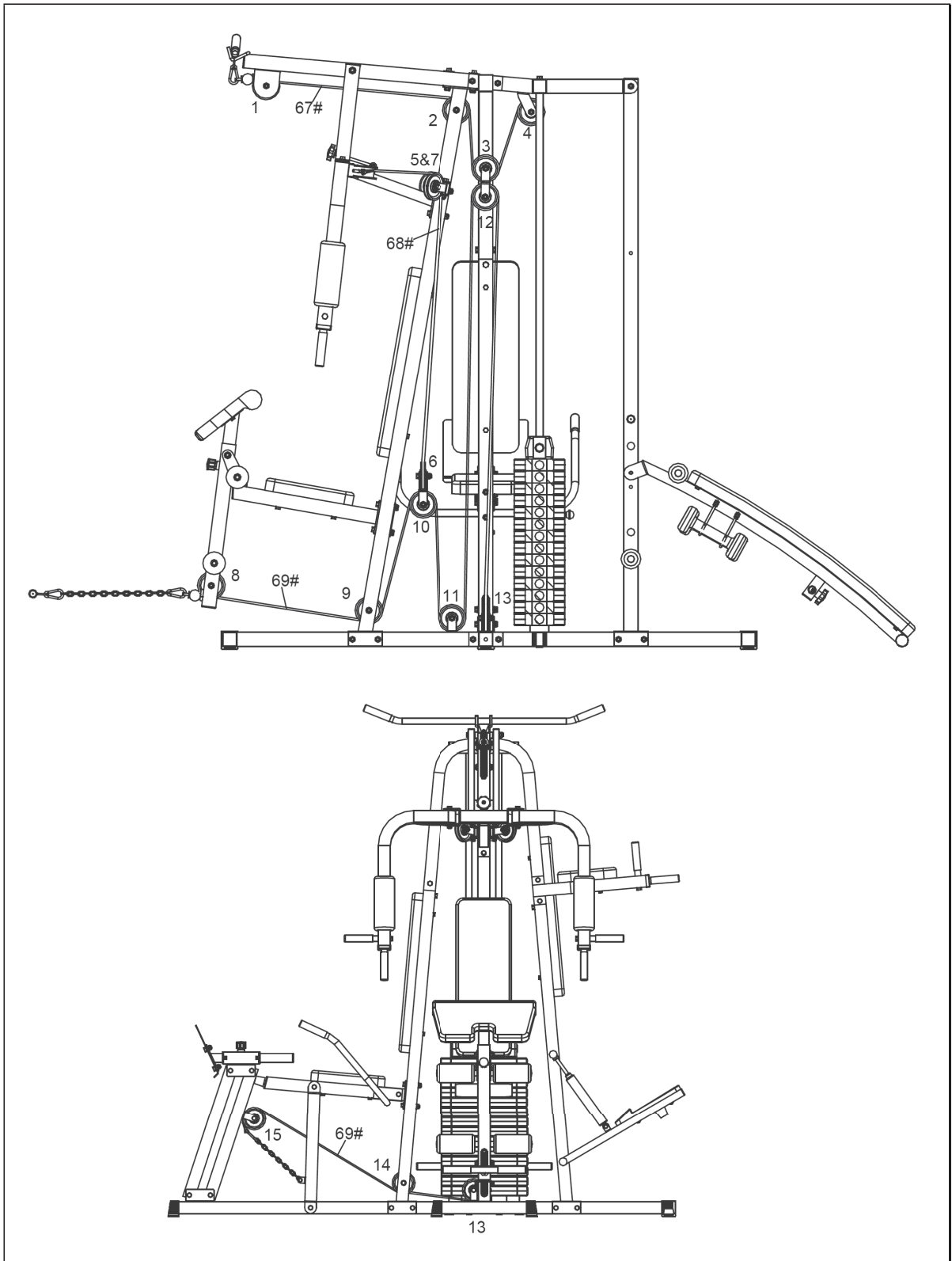

## ÉCHAUFFEMENT AVANT L'ENTRAÎNEMENT

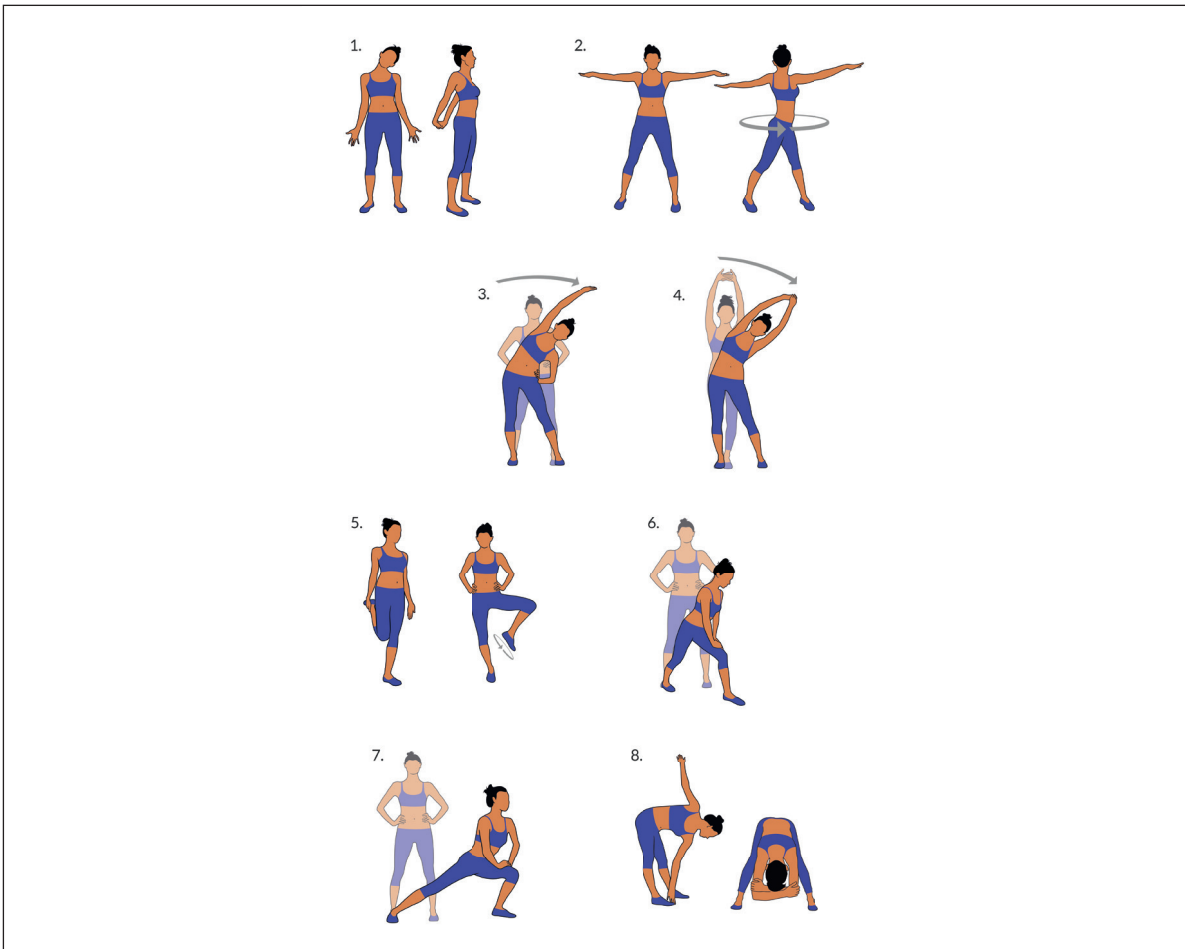

Führen Sie die Aufwärmbewegungen vor jeder Trainingseinheit durch. So mobilisieren Sie Ihre Gelenke und aktivieren die Effectuez Les mouvements d'échauffement avant chaque séance d'entraînement. Vous mobilisez ainsi vos articulations et activez vos muscles.

Si vous ne vous sentez pas bien en effectuant certains mouvements ou que vous ressentez des douleurs, n'effectuez pas cet exercice et convenez avec votre médecin ou votre coach de fitness d'une méthode d'échauffement spécifique.

Chaque mouvement doit en principe être répété plusieurs fois (à droite et à gauche) afin que vous puissiez commencer le cardio-training de façon détendue.

### Prenez environ 5 minutes pour effectuer la séquence d'entraînement Klarfit suivante :

1. Inclinez la tête sur le côté, en alternant lentement de droite à gauche. Puis mobilisez les épaules (mouvements circulaires et des haussements d'épaules).
2. Tournez les hanches en gardant les bras étirés. Les pieds ne doivent pas rester collés au sol (les chevilles accompagnent la rotation du corps).
3. Pliez vos hanches, un bras tendu vers le haut. Restez dans cette position une seconde de chaque côté.
4. Pliez vos hanches, les deux bras joints vers le haut. Encore une fois, maintenez cette position de chaque côté. L'exercice est un peu plus intense car le deuxième bras est également tendu.
5. Tenez-vous sur une jambe et tenez le cou-de-pied avec votre main. Cela vous fait mobiliser votre cheville et étirer légèrement la cuisse. Si nécessaire, appuyez-vous pour garder votre équilibre. Rester sur une jambe et tourner la cheville en cercle dans les deux sens.
6. Tenez une jambe en avant et reposez le haut de votre corps sur votre cuisse. En plus des genoux et des chevilles, vous mobilisez également les muscles à l'arrière du mollet.
7. Répétez l'exercice du point 6 mais en faisant maintenant un grand pas en avant. Le mouvement s'intensifie maintenant.
8. Penchez-vous vers l'avant en gardant les jambes droites et touchez alternativement le pied opposé avec votre main. Terminez en vous laissant pendre vers le bas décontracté et détendu.



**Gentile cliente,**

La ringraziamo per aver acquistato il dispositivo. La preghiamo di leggere attentamente le seguenti istruzioni per l'uso e di seguirle per evitare possibili danni tecnici. Non ci assumiamo alcuna responsabilità per danni scaturiti da una mancata osservazione delle avvertenze di sicurezza e da un uso improprio del dispositivo. Scansionare il codice QR seguente, per accedere al manuale d'uso più attuale e per ricevere informazioni sul prodotto.

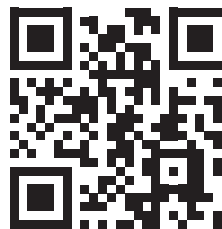

---

**INDICE**

---

Avvertenze di sicurezza 96  
Panoramica delle singole parti 97  
Assemblaggio 101  
Installazione dei cavi 112  
Riscaldamento prima dell'allenamento 115

---

**PRODUTTORE E IMPORTATORE (UK)**

---

**Produttore:**

Chal-Tec GmbH, Wallstraße 16, 10179 Berlino, Germania.

**Importatore per la Gran Bretagna:**

Berlin Brands Group UK Limited  
PO Box 42  
272 Kensington High Street  
London, W8 6ND  
United Kingdom

---

**PULIZIA E MANUTENZIONE**

---

**Nota:** come per tutti i dispositivi da allenamento con componenti meccanici in movimento, le viti possono allentarsi a causa dell'uso frequente. Si raccomanda pertanto di controllarle regolarmente e, se necessario, di serrarle nuovamente con una chiave adatta. Pulire regolarmente il dispositivo con un panno umido per rimuovere sudore e polvere.

- Pulire regolarmente l'apparecchio con un panno umido e uno asciutto.
- L'uso sicuro dell'apparecchio può essere garantito solo se l'apparecchio viene regolarmente controllato per verificare la presenza di danni e usura (ad es. su maniglie, pedali, selle, ecc.). È essenziale che le parti danneggiate vengano sostituite e che l'apparecchio non venga riutilizzato fino a quando non sia stato riparato.
- Controllare regolarmente che bulloni e dadi siano serrati correttamente.
- Lubrificare regolarmente le parti in movimento dell'apparecchio.

## AVVERTENZE DI SICUREZZA







Leggere attentamente tutto il manuale prima di procedere all'uso del dispositivo e conservarlo per future consultazioni. Le caratteristiche del prodotto possono essere leggermente diverse da quelle rappresentate nelle immagini. Il produttore si riserva il diritto di effettuare modifiche senza preavviso.



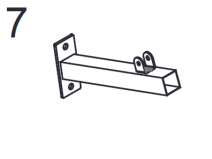
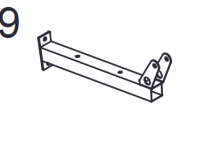

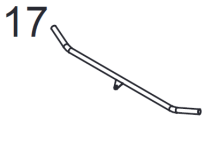
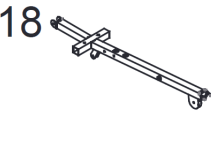



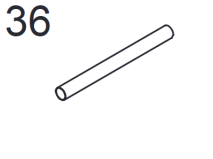
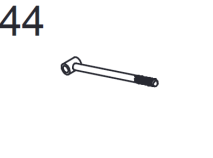









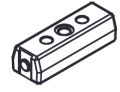
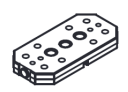





















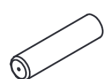



- Conservare il manuale d'uso in un luogo sicuro, in modo da poterlo consultare in ogni momento.
- Procedere al montaggio del dispositivo solo dopo aver letto l'intero manuale d'uso. La sicurezza e l'efficacia del dispositivo sono garantite solo in caso di montaggio corretto e a regola d'arte e in un contesto di utilizzo appropriato. È responsabilità dell'acquirente garantire che tutti gli utilizzatori del dispositivo siano informati riguardo alle avvertenze di sicurezza e alle misure a cui è necessario prestare attenzione.
- Il dispositivo deve essere posizionato su una superficie piana e stabile per poter essere utilizzato in sicurezza. Per proteggere il pavimento, utilizzare un tappetino. Non utilizzare il dispositivo in ambienti umidi, ad es. vicino a piscine, ecc. La distanza di sicurezza intorno al dispositivo deve essere di almeno 0,6 metri.
- Prima di iniziare il programma di allenamento, consultare assolutamente un medico, per assicurarsi di non avere problemi fisici o di salute che potrebbero rappresentare un rischio per il vostro benessere o la vostra sicurezza attraverso l'uso del dispositivo o che potrebbero impedire il corretto utilizzo del dispositivo. Il parere del medico è di importanza vitale se si assumono medicinali che influiscono sul battito cardiaco, sulla pressione sanguigna o sul tasso di colesterolo.
- Prestate attenzione ai segnali del vostro corpo. Un allenamento errato o eccessivo può essere dannoso per la salute. Interrompere l'allenamento se dovesse comparire uno dei seguenti sintomi: dolore, sensazione di pressione sul petto, battito cardiaco irregolare, estrema mancanza di fiato, giramenti di testa o nausea. Se uno di questi sintomi dovesse comparire, consultare assolutamente un medico prima di procedere con l'allenamento.
- Non allenarsi subito dopo i pasti.
- Il dispositivo può essere montato solo da persone adulte. Tenere i bambini lontano dal dispositivo.
- Il dispositivo può essere utilizzato esclusivamente in ambienti casalinghi.
- Il dispositivo non è adatto a usi terapeutici. Può essere utilizzato solo per gli esercizi descritti nel manuale.
- Indossare un abbigliamento adeguato e scarpe da allenamento durante l'utilizzo del dispositivo. Evitare abiti larghi che potrebbero restare impigliati nel dispositivo o indumenti che limitano la libertà di movimento.
- Tenere la schiena dritta durante l'allenamento.
- Prima di ogni utilizzo, controllare che impugnature, sella, dadi e bulloni siano avvitati saldamente.
- Rispettare la posizione massima per i componenti del dispositivo regolabili e non superare mai il segno "Stop", in quanto potrebbero insorgere rischi.
- Utilizzare il dispositivo solo secondo le modalità descritte. Se durante il montaggio o il controllo doveste notare componenti difettose o udire strani rumori durante l'utilizzo, interrompete immediatamente l'utilizzo. Tornare ad utilizzare il dispositivo solo dopo aver risolto il problema.
- Quando si solleva o si sposta il dispositivo, fare attenzione a non farsi male alla schiena. Utilizzare sempre una tecnica di sollevamento appropriata e, in caso, chiedere l'aiuto di un'altra persona.
- Tutti i componenti mobili (ad es. pedali, impugnature, sella, ecc.) devono essere mantenuti settimanalmente. Controllarli prima di ogni utilizzo. Se qualcosa dovesse essere allentato o rotto, procedere immediatamente alla riparazione o al fissaggio. Utilizzare il dispositivo solo dopo aver ristabilito la condizione ottimale.
- Fare attenzione alla mancanza di ruota libera, che rappresenta un serio rischio.
- Tenere il cavo di alimentazione lontano da fonti di calore.
- Non inserire oggetti nelle aperture del dispositivo.
- Prima di spostare o pulire il dispositivo, spegnerlo e staccare la spina. Sfregare le superfici con un detergente delicato e un panno umido. Non utilizzare solventi.
- Non utilizzare il dispositivo in luoghi non temperati, come ad es. garage, verande, bagni, carport o all'aperto.
- Utilizzare il dispositivo esclusivamente secondo le modalità descritte nel manuale d'uso.
- Una riparazione errata e modifiche strutturali (ad es. la rimozione o sostituzione di parti originali) possono mettere in pericolo l'utilizzatore del dispositivo.
- Il volano diventa estremamente caldo durante l'utilizzo.
- Attivare il tasto di blocco quando non si utilizza il dispositivo.
- I bambini a partire dagli 8 anni, i portatori di handicap mentali e fisici possono utilizzare l'apparecchio solo se hanno avuto una conoscenza approfondita delle funzioni e delle precauzioni di sicurezza da parte di un supervisore responsabile.
- Assicurarsi che i bambini non giochino con l'apparecchio.
- Prima dell'uso, controllare la tensione sulla targhetta. Collegare l'apparecchio solo a prese corrispondenti alla tensione dell'apparecchio.

**Avvertenza:** peso massimo dell'utilizzatore: 120 kg.































## PANORAMICA DELLE SINGOLE PARTI

1 	2 	3 	4 	5 
6 	7 	8 	9 	10 
11 	12 	13 	14 	15 
16 	17 	18 	19 	20 
21 	22 	23 	24 	25 
26 	27 	28 	29 	30 
31 	32 	33 	34 	35 
36 	37 	38 	39 	40 
41 	42 	43 	44 	45 

46 	47 	48 	49 	50 
51 	52 	53 	54 	55 
56 	57 	58 	59 	60 
61 	62 	63 	64 	65 
66 	67 	68 	69 	70 
71 	72 	73 	74 	75 
76 	77 	78 	79 	80 
81 	82 	83 	84 	85 
86 	87 	88 	89 	90 

Nr.	Descr.	Pz.	Nr.	Descr.	Pz.
1	Telaio di base	1	46	Cuscino Schienale	3
2	Gamba Telaio di Base	1	47	Cuscino sedile	2
3	Telaio di Base	1	48	Cuscino Bracciolo	1
4	Peso - Tubo di Guida	4	49	Cuscino Panca	1
5	Peso Carrello	1	50	Cuscino Bracciolo	2
6	Telaio di Supporto	1	51	Cuscino Estensione Gambe	4
7	Asta per la Resistenza	1	52	Rotolo Schiuma per Braccioli	2
8	Prolunga Gambe	1	53	Rotoli Schiuma	4
9	Sedile Telaio	1	54	Piastra Peso Superiore	1
10	Braccio	1	55	Piastre Peso	14
11	Braccio a Farfalla destro	1	56	Puleggia	15
12	Braccio Farfalla sinistro	1	57	Perno Selezione Peso	1
13	Barra di Pressione	1	58	Moschettone	4
14	Tubo lungo in schiuma	2	59	Ammortizzatore (lungo)	1
15	Tubo Manubrio	4	60	Ammortizzatore (corto)	2
16	Tubo Inferiore	1	61	Vite Di Bloccaggio	1
17	Barra di Tiro Laterale	1	62	Catena Lunga	1
18	Traversa Superiore	1	63	Catena Corta	1
19	Supporto Inferiore (pressa gambe)	1	64	Vite di Bloccaggio	1
20	Supporto superiore (pressa gambe)	1	65	Boccola Olio	2
21	Telaio Sedile (pressa gambe)	1	66	Perno di Sicurezza	1
22	Telaio Supporto Sedile (pressa gambe)	1	67	Cavo Superiore	1
23	Telaio Anteriore Pressa Gambe Dritte	1	68	Farfalla-Cavo	1
24	Telaio Posteriore Pressa Gambe Dritte	1	69	Cavo Inferiore	1
25	Telaio di Collegamento Pressa Gambe	1	70	Manopola di Regolazione	2
26	Telaio di Regolazione Delle Gambe Pressa Gambe	1	71	Rondella	1
27	Piattaforma Pressa Gambe	1	72	Anello in Plastica	1
28	Corrimano Pressa Gambe	1	73	Pin	1
29	Telaio Panca	1	74	Band	1
30	Telaio Supporto Pedali	2	75	Manubrio	2
31	Telaio di Supporto Inferiore	1	76	Rondella in Gomma	2
32	Telaio di Supporto Superiore	1	77	Maniglia	18
33	Curva Destra	1	78	50 mm Tappo Terminale Quadrato	7
34	Curva Sinistra	1	79	Tappo Terminale	1
35	Telaio Posteriore Verticale	1	80	Tappo Centrale	4
36	Tubo Maniglia Bank	1	81	50 mm Tappo Centrale	8
37	Tubo in Schiuma Corto	1	82	38 mm Tappo Centrale	2
38	Tubo Manubrio Lungo	1	83	30 x 60 mm Tappo Centrale	2
39	Doppio Componente-U ruotato	1	84	25 x 50 mm Tappo Centrale	2
40	Doppio Componente- U	1	85	Tappo Pedale Grande	4
41	Singolo Componente - U	2	86	25 mm Tappo Terminale Rotondo	8
42	Piastra	1	87	Tappo Centrale Quadrato	2
43	Gancio per Manubrio	4	88	Pedale	2
44	Bullone (a forma di pipa di tabacco)	1	89	Presa (piccola)	8
45	Cilindro	2	90	Presa di Plastica	4

## Piccoli pezzi

91 	92 	93 	94 	95 
96 	97 	98 	99 	100 
101 	102 	103 	104 	105 
106 	107 	108 	109 	110 
111 	112 	113 	114 	115 
116 	117 	118 		

Nr.	Descr.	Pz.	Nr.	Descr.	Pz.
91	38 mm Tappo Terminale Rotondo	2	105	M10 x 70 mm Vite 4	4
92	Coperchio in Plastica	2	106	M8 x 65 mm Vite a Testa Esagonale	16
93	38 mm Tappo Quadrato	1	107	M8 x 40 mm Vite Esagonale	4
94	Tappo Tampone	2	108	M8 x 16 mm Vite a Testa Esagonale	10
95	Tappo a Vite	4	109	M6 x 40 mm Vite 4	4
96	M12x150 mm Vite a Testa Esagonale	1	110	M12 Rondella	4
97	M12 x 75 mm Vite Esagonale	1	111	Ø30xØ10 Rondella	1
98	M10 x 75 mm Vite Esagonale	2	112	M10 Rondella	111
99	M10 x 75 mm Vite Esagonale	6	113	Ø25xØ8 Rondella	4
100	M10 x 70 mm Vite Esagonale	29	114	M8 Rondella	32
101	M10 x 65 mm Vite Esagonale	2	115	M6 Rondella	4
102	M10 x 45 mm Vite Esagonale	11	116	M12 Dado Nylon	2
103	M10 x 25 mm Vite Esagonale	2	117	M10 Dado Nylon	52
104	M10 x 20 mm Vite Esagonale	7	118	M8 Dado Nylon	6

## ASSEMBLAGGIO

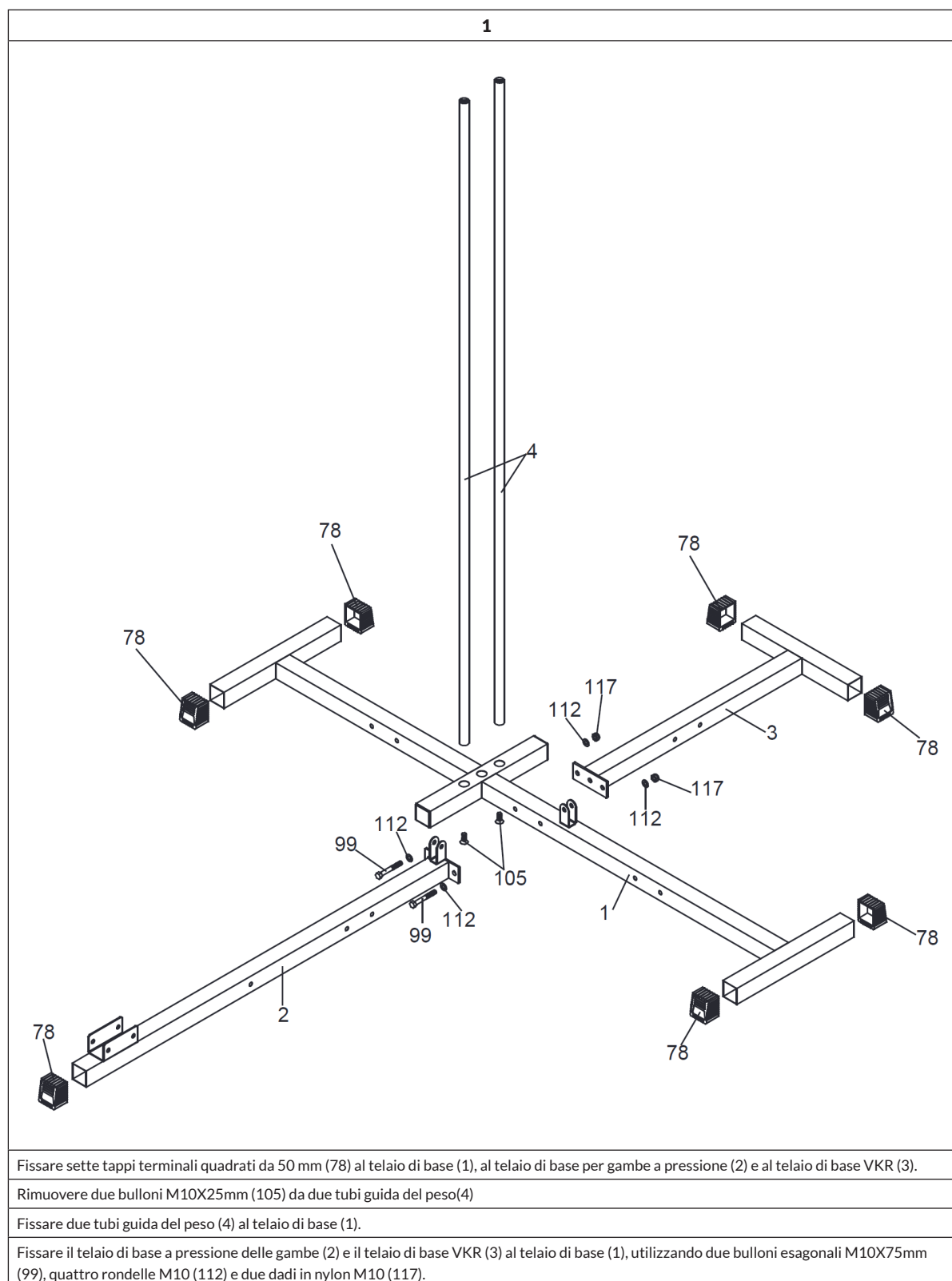

Fissare sette tappi terminali quadrati da 50 mm (78) al telaio di base (1), al telaio di base per gambe a pressione (2) e al telaio di base VKR (3).

Rimuovere due bulloni M10X25mm (105) da due tubi guida del peso (4)

Fissare due tubi guida del peso (4) al telaio di base (1).

Fissare il telaio di base a pressione delle gambe (2) e il telaio di base VKR (3) al telaio di base (1), utilizzando due bulloni esagonali M10X75mm (99), quattro rondelle M10 (112) e due dadi in nylon M10 (117).

2

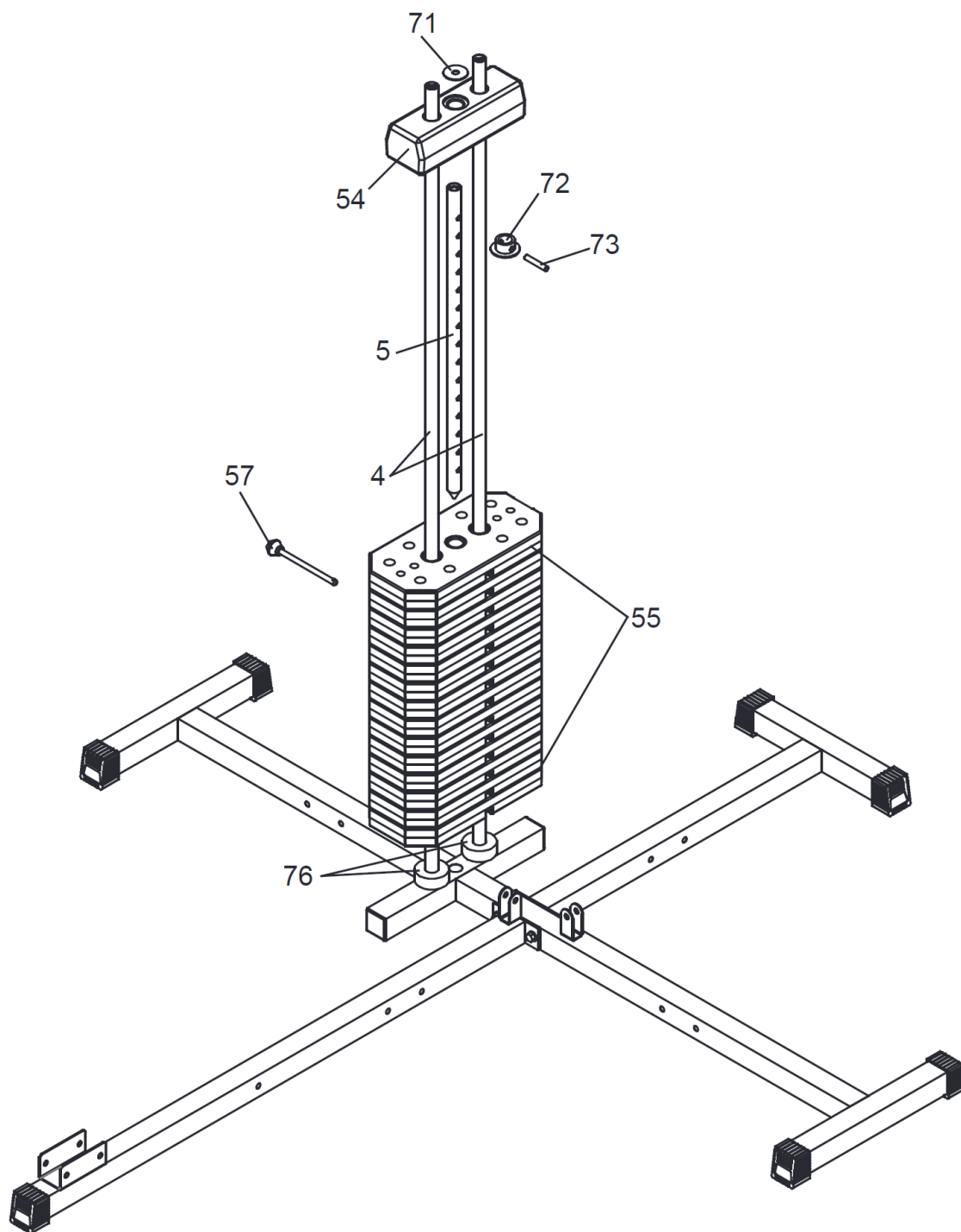

Far scorrere due cuscini in gomma (76) lungo il tubo di guida del peso (4).

Far scorrere quattordici piastre di peso (55) lungo il tubo di guida del peso (4).

Far scorrere la boccia dell'albero del selettore (72) giù dall'albero del selettore (5) al primo foro fissato con il perno dell'albero del selettore (73).

Inserire l'albero del selettore (5) nel foro della piastra di pesatura (55).

Far scorrere la piastra di pesatura superiore (54) lungo il tubo di guida del peso (4), inserire la spina del selettore del peso (57) nel foro del peso desiderato.

Posizionare la rondella di plastica (71) sulla piastra del peso superiore (54).

3

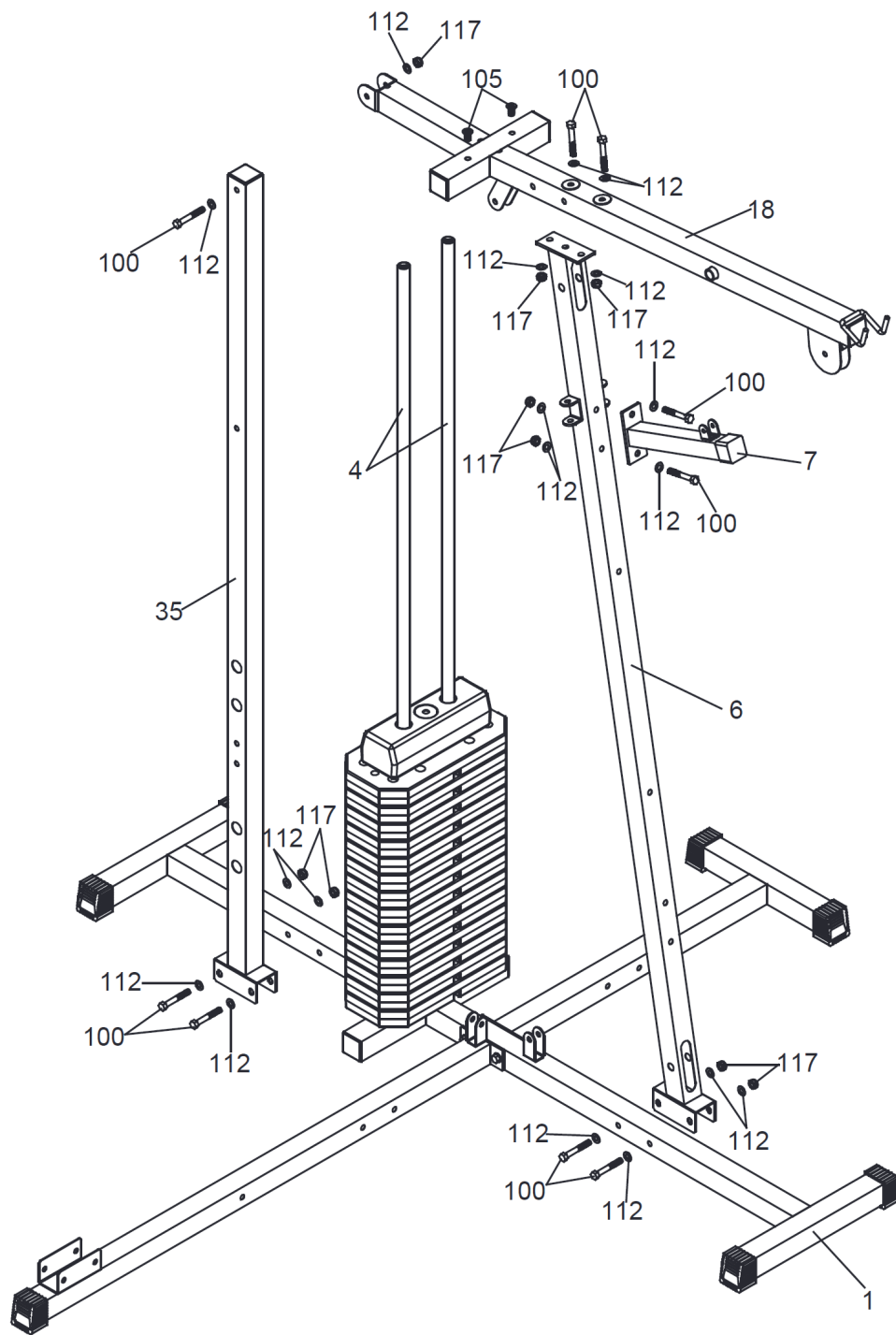

Fissare il telaio di supporto (6) e il telaio verticale posteriore (35) al telaio di base (1), utilizzando quattro bulloni esagonali M10X70mm (100), otto rondelle M10 (112) e quattro dadi in nylon M10 (117).

Rimuovere due bulloni M10X25mm (105) da due tubi guida del peso (4).

Fissare la traversa superiore (18) ai due tubi guida del peso (4), utilizzando due bulloni M10X25mm (105).

Fissare la traversa superiore (18) al telaio di supporto (6) e al telaio verticale posteriore (35), utilizzando tre bulloni esagonali M10X70mm (100), sei rondelle M10 (112) e tre dadi in nylon M10 (117).

Fissare la barra di resistenza (7) al telaio di supporto (6), utilizzando due bulloni esagonali M10X70mm (100), quattro rondelle M10 (112) e due dadi in nylon M10 (117).

4

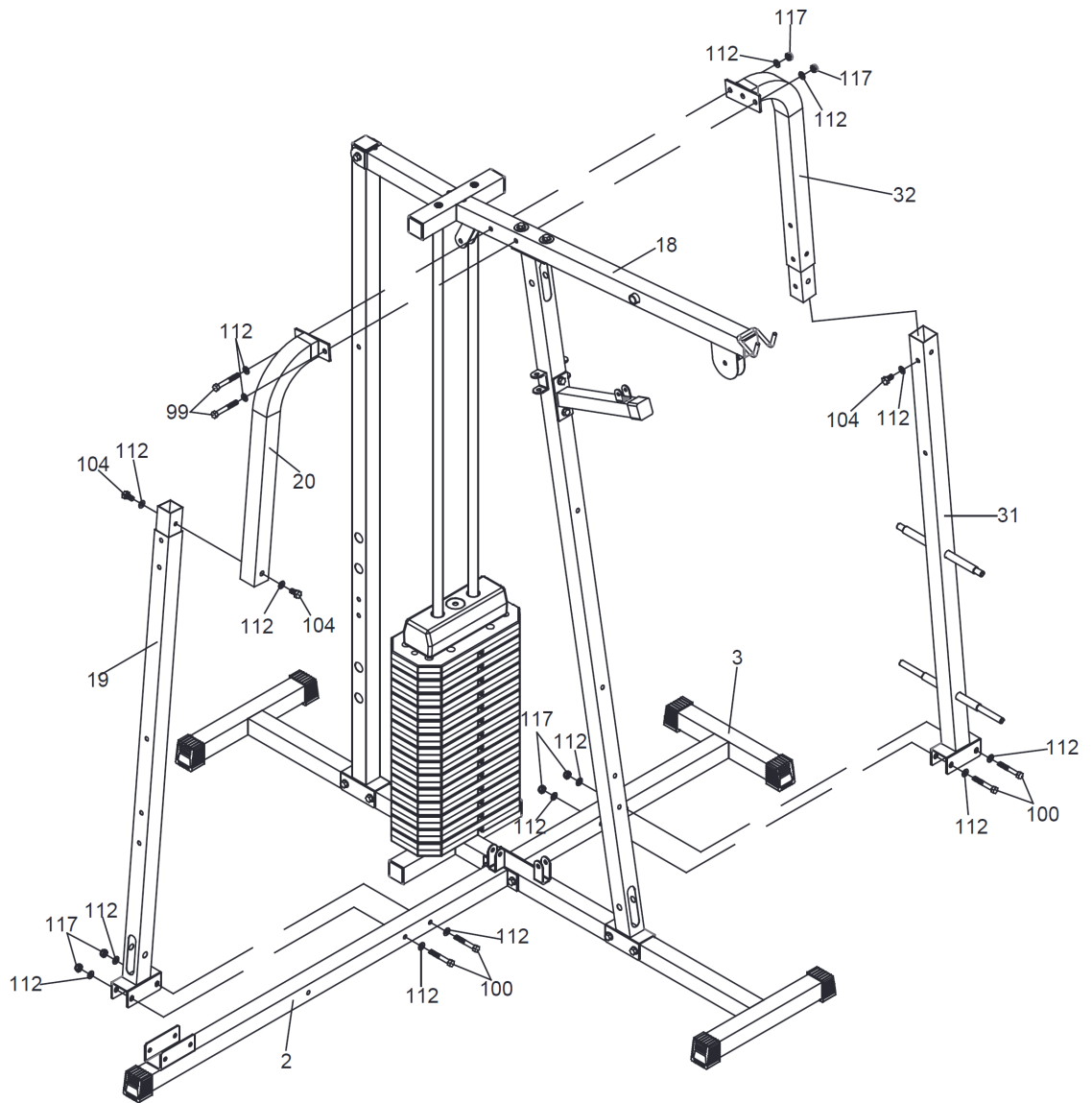

Fissare il telaio di supporto inferiore della pressa gambe (19) al telaio di base della pressa gambe (2), utilizzando due bulloni esagonali M10X70mm (100), quattro rondelle M10 (112) e due dadi in nylon M10 (117).

Fissare il telaio di supporto inferiore VKR (31) al telaio di base VKR (3), utilizzando due bulloni esagonali M10X70mm (100), quattro rondelle M10 (112) e due dadi in nylon M10 (117).

Fissare il telaio di supporto superiore della pressa gambe (20) al telaio di supporto inferiore della pressa gambe (19), utilizzando due bulloni esagonali M10X20mm (104) e due rondelle M10 (112).

Fissare il telaio di supporto superiore VKR (32) al telaio di supporto inferiore VKR (31), utilizzando un bullone esagonale M10X20mm (104) e una rondella M10 (112).

Fissare il telaio di supporto superiore della pressa gambe (20) e il telaio di supporto superiore VKR (32) alla traversa superiore (18), utilizzando due tamponi esagonali M10X75mm (99), quattro rondelle M10 (112) e due dadi in nylon M10 (117).



5

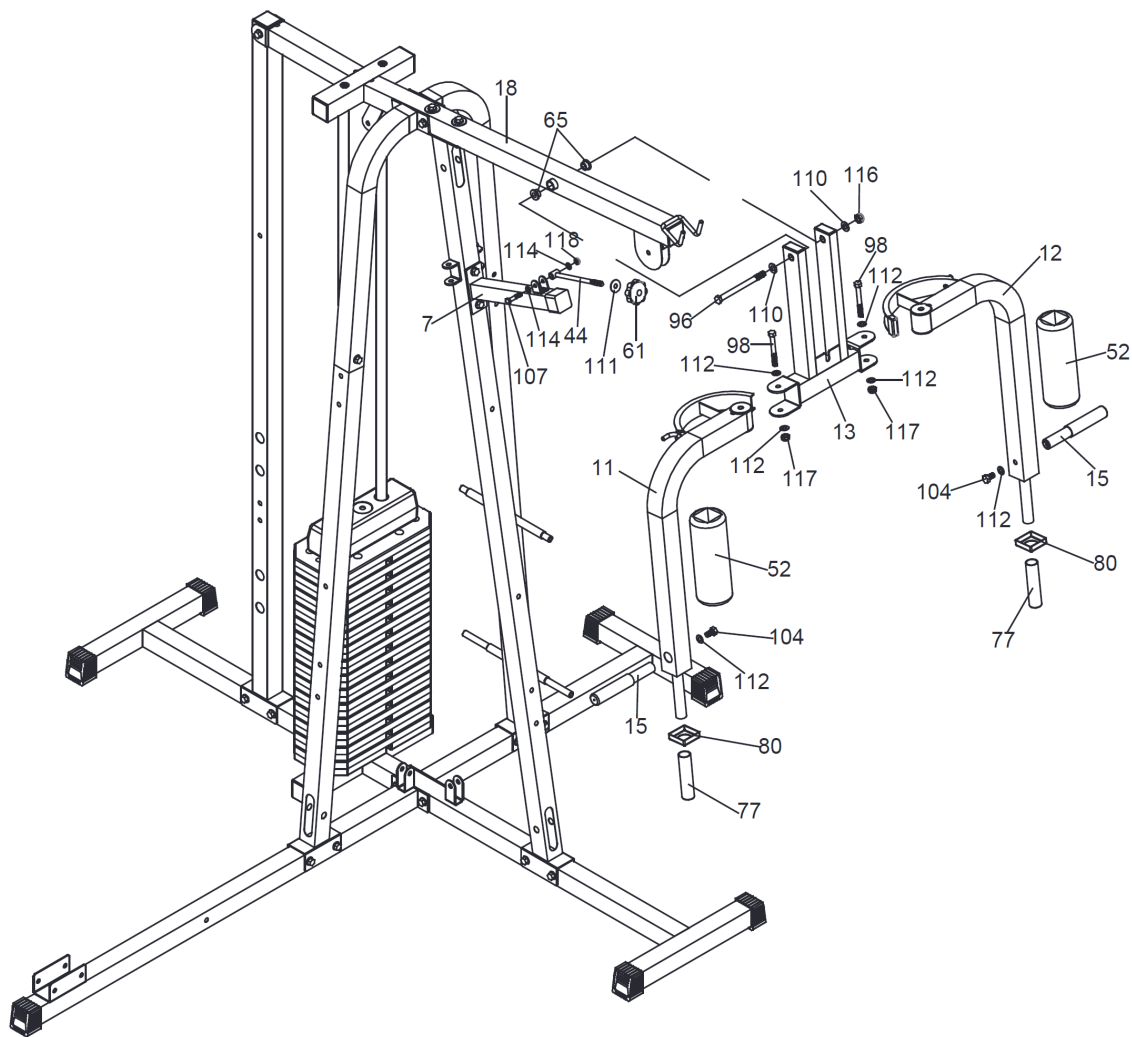

**Nota:** La boccola d'olio (65) è stata preassemblata sulla traversa superiore(18).

Fissare la barra di pressione (13) alla traversa superiore (18), utilizzando un bullone esagonale M12x150mm (96), due rondelle M12(110) e un dado in nylon M12(116).

Fissare il braccio a farfalla sinistro e destro (11&12) alla barra di stampa (13), utilizzando due bulloni esagonali M10X85mm (98), quattro rondelle M10 (112) e due dadi in nylon M10 (117).

Far scorrere due rulli in schiuma del braccio (52) sul braccio a farfalla sinistro e destro (11 e 12).

Rimuovere due bulloni esagonali M10X20mm (104) e due rondelle M10 (112) da due tubi della maniglia (15).

Collegare due tubi della maniglia (15) al braccio a farfalla sinistro e destro (11 e 12), utilizzando due bulloni esagonali M10X20mm (104) e due rondelle M10 (112).

Far scorrere due spine quadrate a vuoto medio (80) e due impugnature (77) sul braccio a farfalla sinistro e destro (11 e 12).

Collegare il tubo del tabacco (44) alla barra di resistenza (7), utilizzando un bullone esagonale M8X40mm (107), due rondelle M8 (114) e un dado in nylon M8 (118).

Far scorrere la rondella (111) e il dado per fiori di susina (61) sul tubo del tabacco (44).

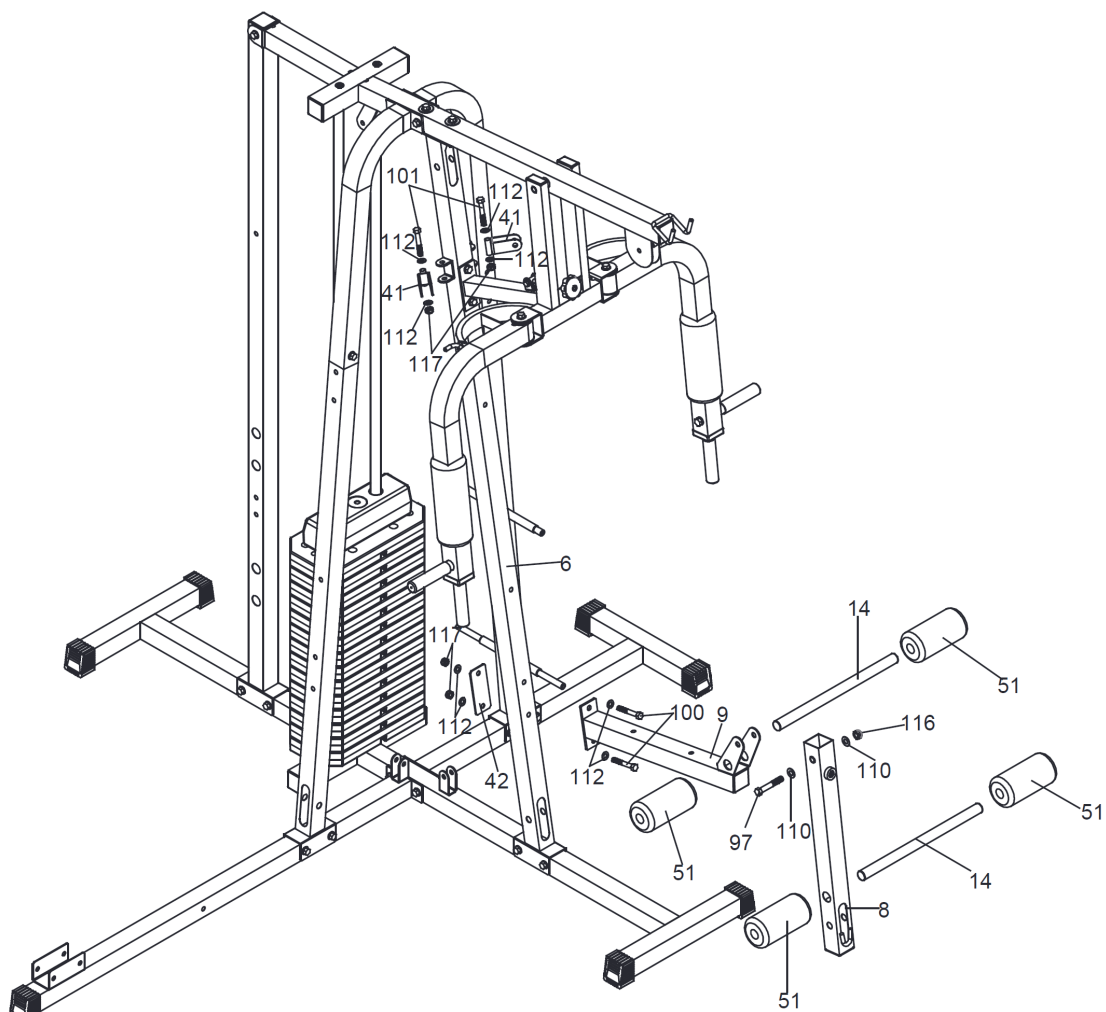

Fissare il telaio del sedile (9) e la piastra (42) al telaio di supporto (6), utilizzando due bulloni esagonali M10X70mm (100), quattro rondelle M10 (112) e due dadi in nylon M10 (117).

Fissare il telaio di prolunga gambe (8) al telaio della sella (9), utilizzando un bullone esagonale M12X75mm (97), due rondelle M12 (110) e un dado in nylon M12 (116).

Inserire due tubi lunghi in schiuma (14) nel telaio di prolunga gambe (8) e nel telaio del sedile (9).

Far scorrere le quattro schiume di prolunga gambe (51) sul tubo in schiuma lunga (14).

Fissare i due blocchi di pulegge singole (41) al telaio di supporto (6), utilizzando due bulloni esagonali M10X65mm (101), quattro rondelle M10 (112) e due dadi in nylon M10 (117).

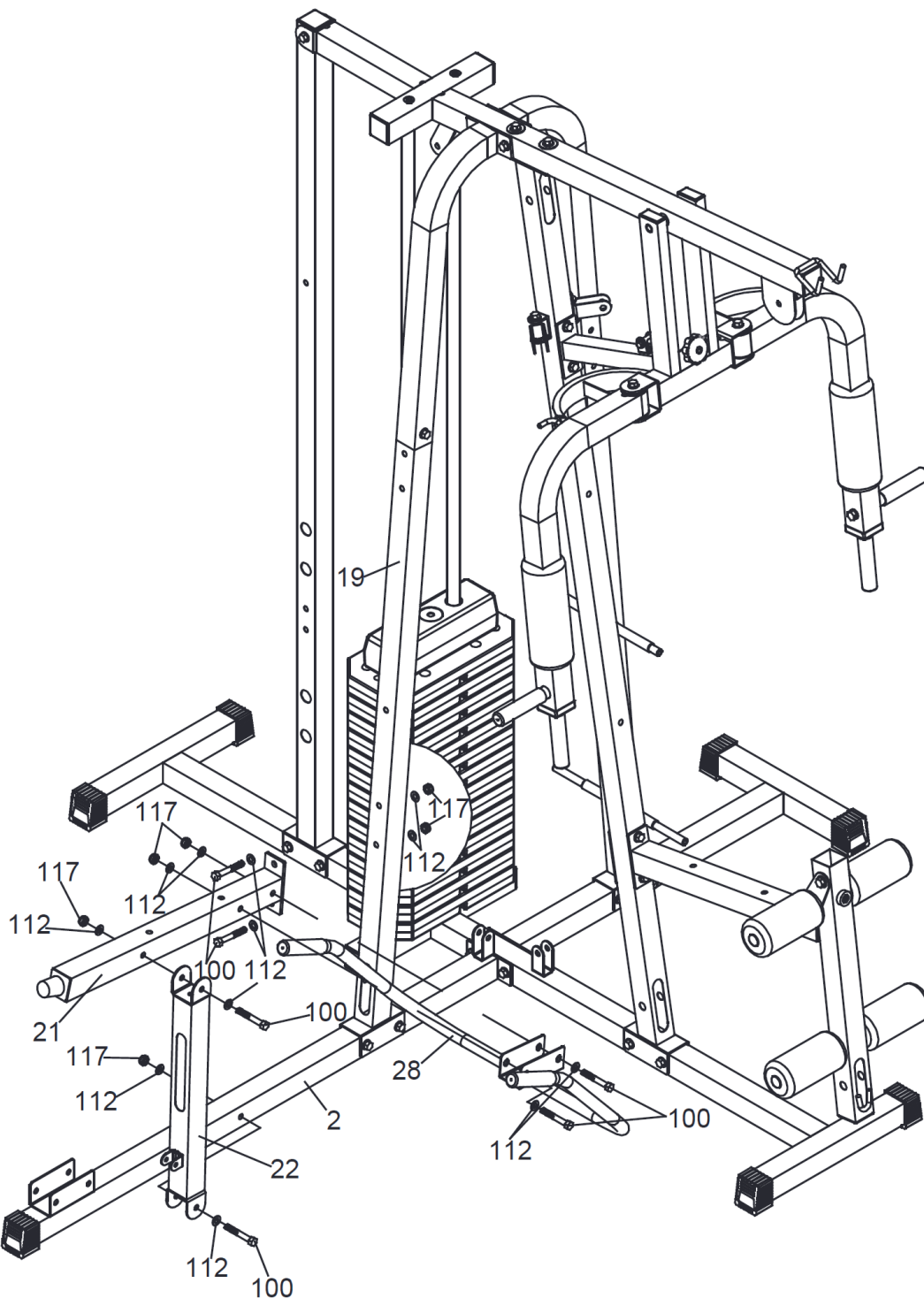

Fissare il telaio di supporto del sedile della pressa gambe (22) al telaio della base della pressa gambe (2), utilizzando un bullone esagonale M10X70mm (100), due rondelle M10 (112) e un dado in nylon M10 (117).

Fissare il telaio della sede della pressa gambe (21) al telaio di supporto inferiore della pressa gambe (19) e al telaio di supporto della sede della pressa gambe (22), utilizzando tre bulloni esagonali M10X70mm (100), sei rondelle M10 (112) e tre dadi in nylon M10 (117).

Fissare la barra manuale della pressa gambe (28) al telaio del sedile della pressa gambe (21), utilizzando due bulloni esagonali M10X70mm (100), quattro rondelle M10 (112) e due dadi in nylon M10 (117).

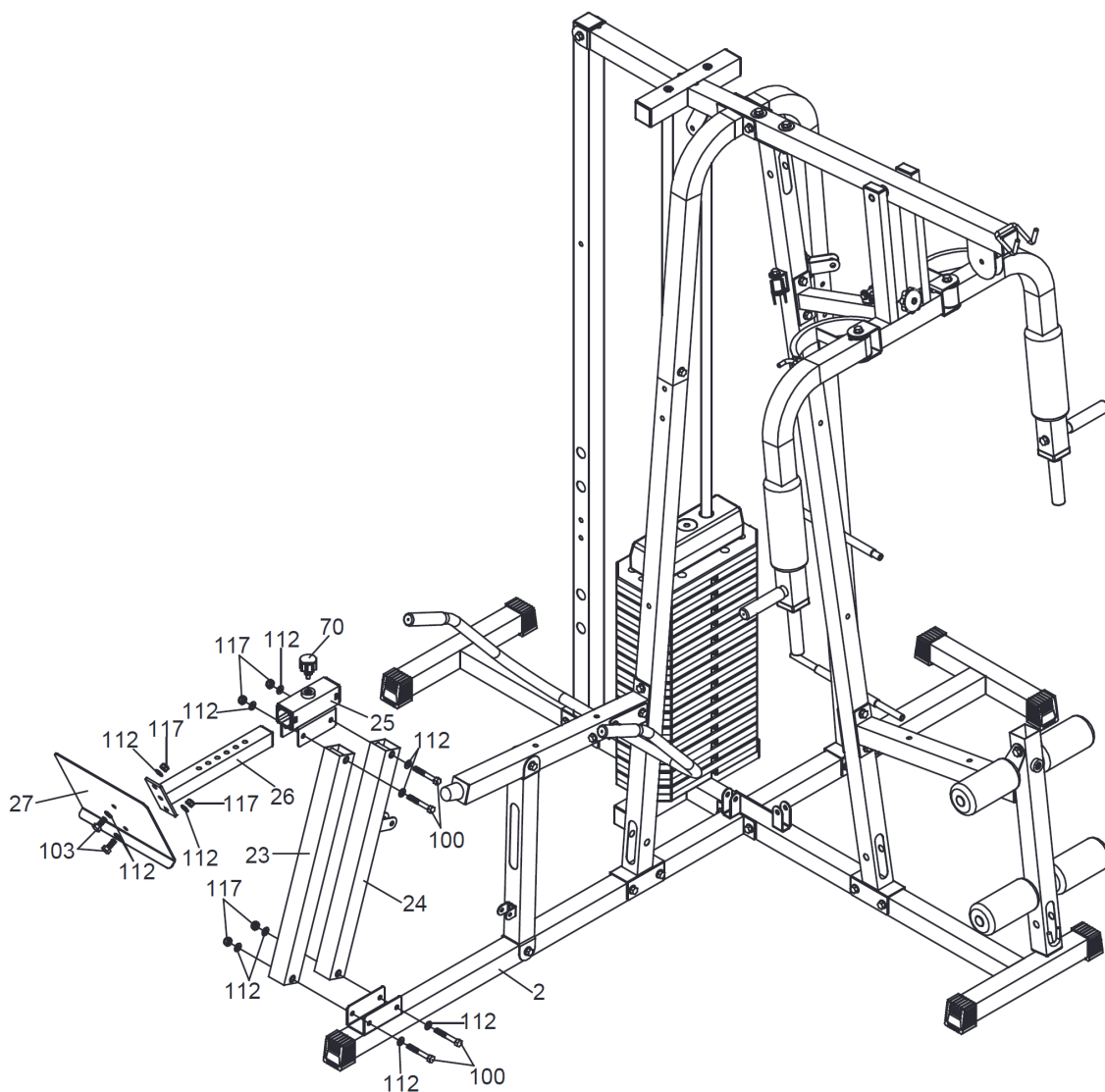

Fissare il telaio verticale anteriore (23) e il telaio verticale posteriore (24) al telaio della base della pressa gambe (2), utilizzando due bulloni esagonali M10X70mm (100), quattro rondelle M10 (112) e due dadi in nylon M10 (117).

Fissare il telaio di collegamento della pressa gambe (25) al telaio verticale della pressa gambe anteriori (23) e al telaio verticale della pressa gambe posteriori (24), utilizzando due bulloni esagonali M10X70mm (100), quattro rondelle M10 (112) e due dadi in nylon M10 (117).

Fissare il piatto della pressa gambe (27) al telaio di regolazione del piatto della pressa gambe (26), utilizzando due bulloni esagonali M10X25mm (103), quattro rondelle M10 (112) e due dadi in nylon M10 (117).

Inserire il telaio di regolazione della piastra di regolazione della pressa gambe (26) nel telaio di collegamento della pressa gambe (25), usando una manopola rapida (70).

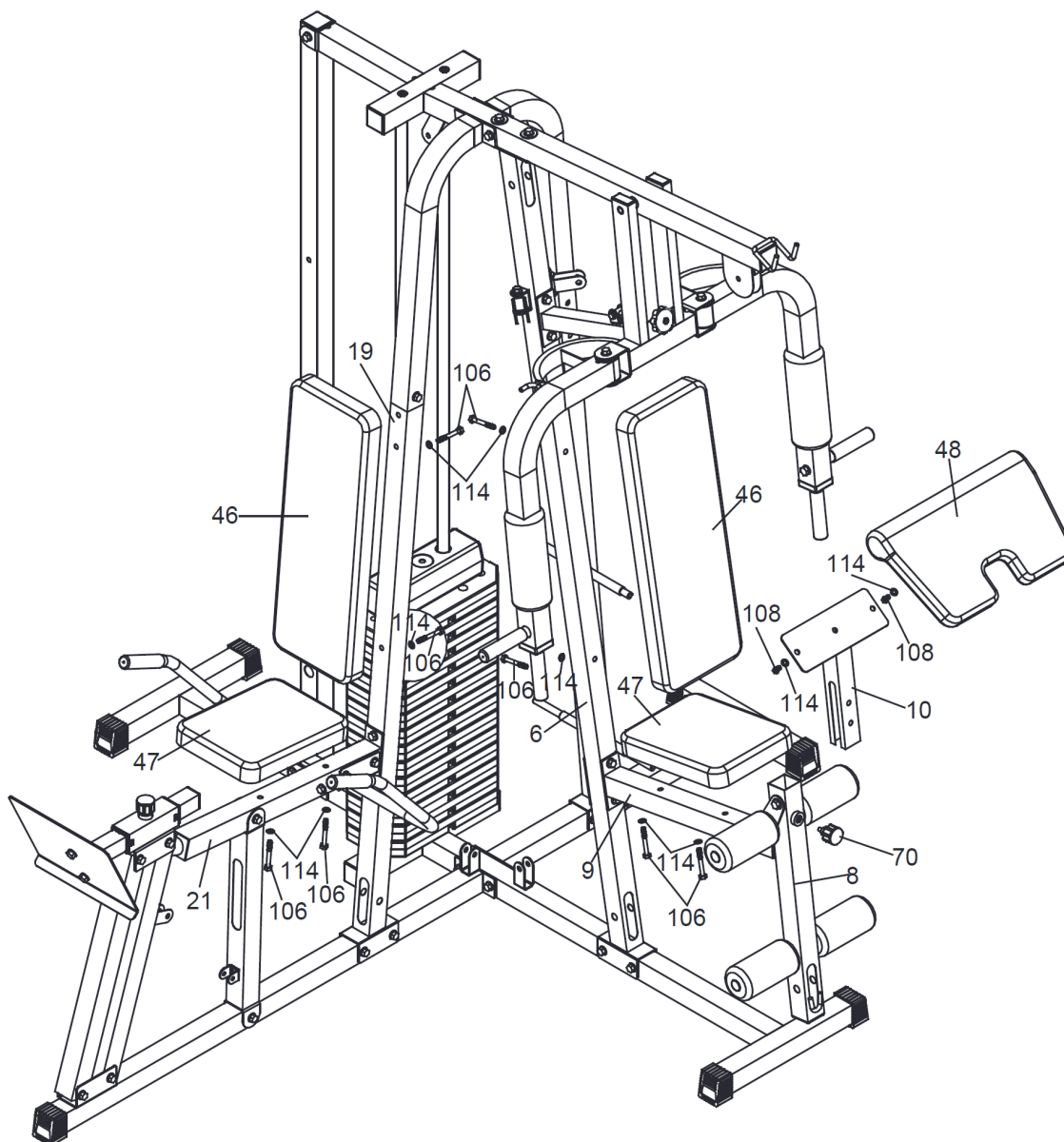

Fissare i due cuscini dello schienale (46) al telaio di supporto (6) e al telaio di supporto inferiore della pressa gambe (19), utilizzando quattro bulloni esagonali M8X65mm (106) e quattro rondelle M8 (114).

Fissare i due cuscini dei sedili (47) al telaio del sedile (9) e al telaio del sedile a pressione delle gambe (21), utilizzando quattro bulloni esagonali M8X65mm (106) e quattro rondelle M8 (114).

Fissare il cuscino del braccio (48) al telaio del braccio (10), utilizzando due bulloni esagonali M8X16mm (108) e due rondelle M8 (114).

Inserire il telaio del braccio (10) nel telaio di estensione delle gambe (8), usando una manopola rapida (70).

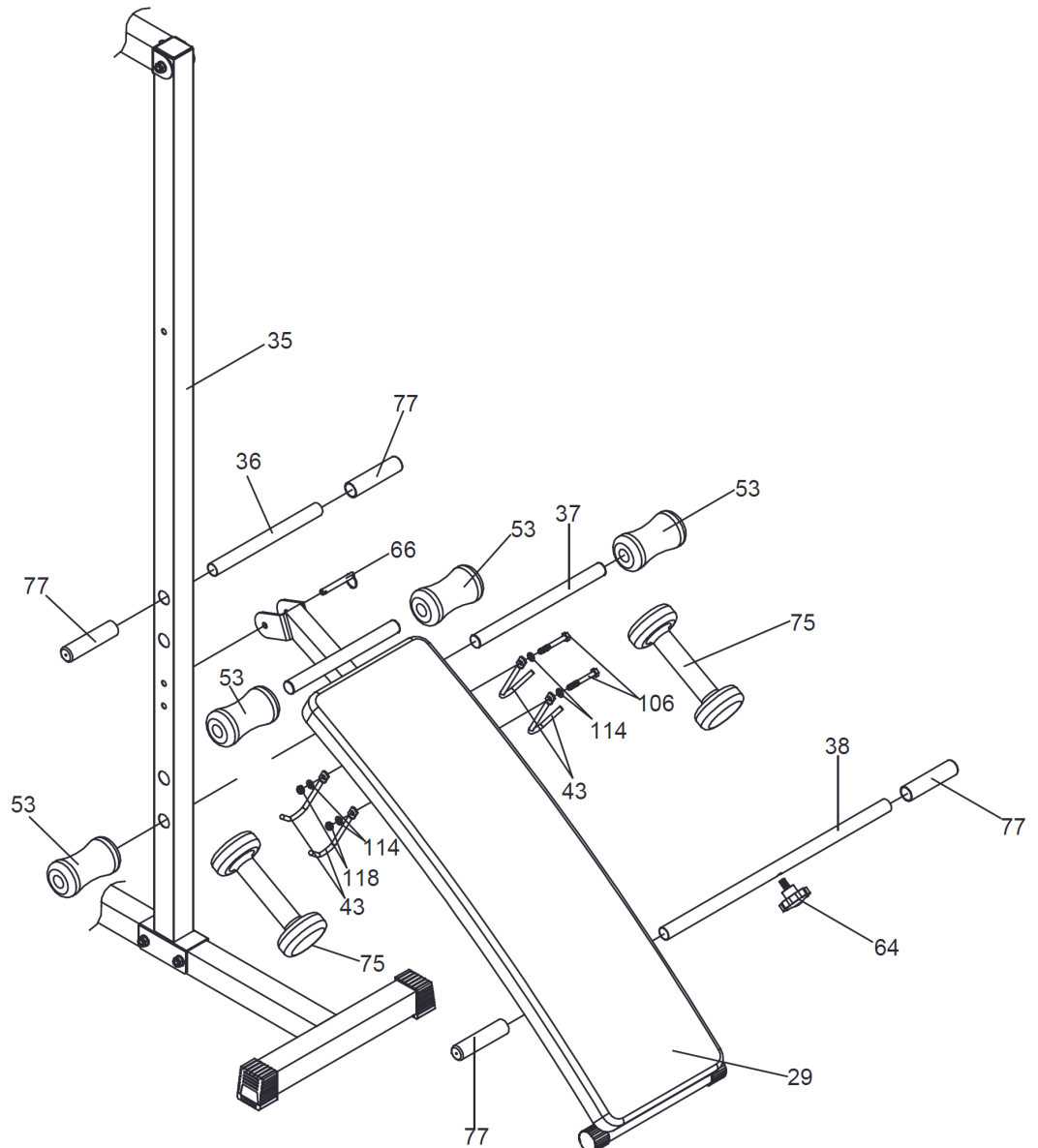

Fissare i quattro ganci Dumbbell (43) al telaio del banco (29), utilizzando due bulloni esagonali M8X65mm (106), quattro rondelle M8 (114) e due dadi in nylon M8 (118). Nei due manubri (75).

Inserire il tubo della maniglia lunga (38) nel telaio del banco (29), usando una manopola (64). Far scorrere due impugnature (77) sul tubo dell'impugnatura lunga (38).

Fissare il telaio da banco (29) al telaio verticale posteriore (35), utilizzando un Quick (66).

Inserire il tubo della maniglia del banco (36) nel telaio verticale posteriore (35). Far scorrere due impugnature della maniglia (77) sul tubo della maniglia del banco (36).

Inserire il tubo corto in schiuma (37) nel telaio del banco (29). Far scorrere quattro schiume da banco (53) sulla canna schiuma corta (37) e sul telaio del banco (29).

11

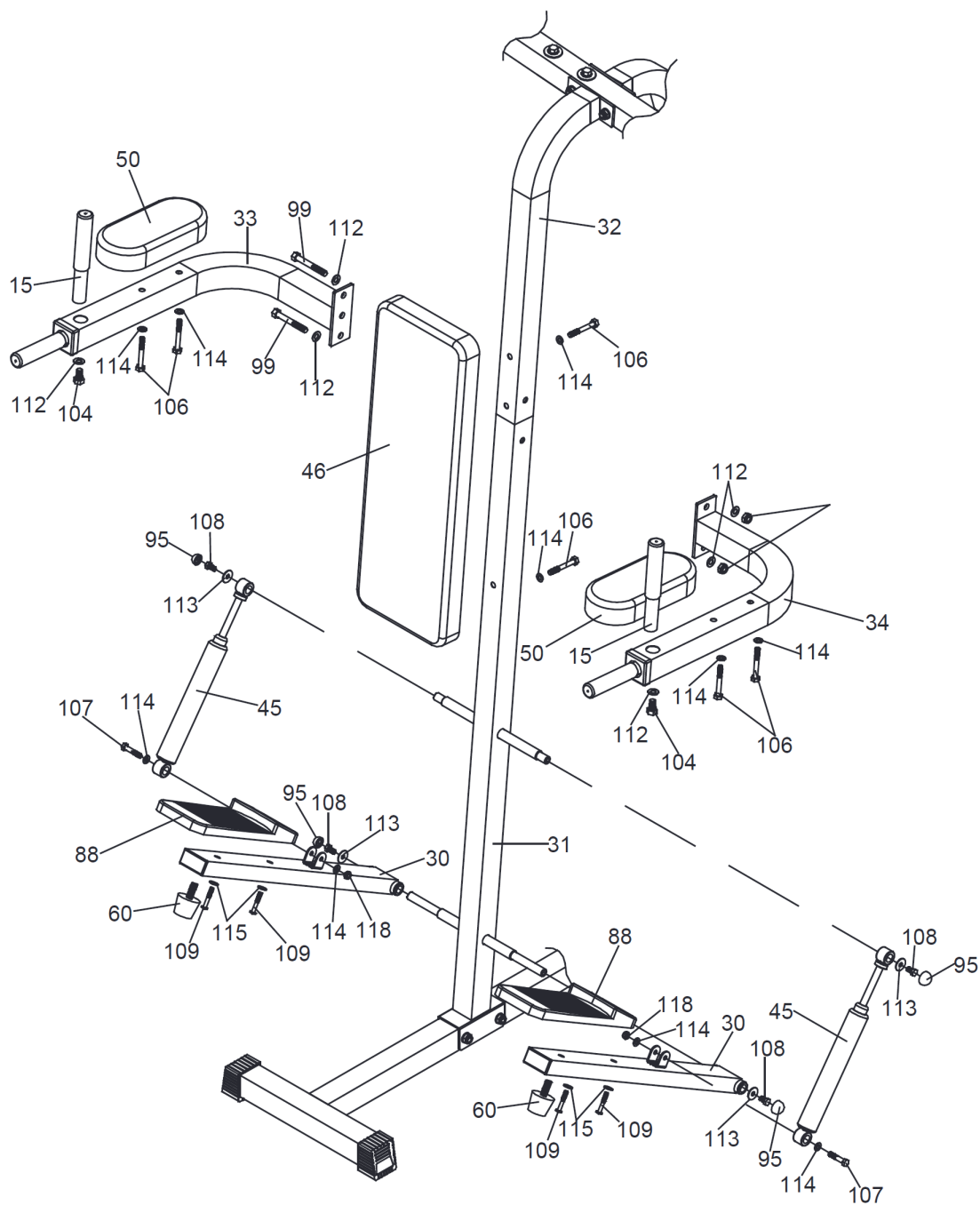

Fissare i due cilindri (45) al telaio inferiore di supporto VKR (31), utilizzando due bulloni esagonali M8X16mm (108), due rondelle (113) e due tappi (95). 4. 4. Fissare i due cilindri (45) ai due telai del pedale (30), utilizzando due bulloni esagonali M8X40mm (107), quattro rondelle M8 (114) e due dadi in nylon M8 (118).

Fissare il VKR destro e sinistro (33&34) al telaio di supporto inferiore (31) e superiore (32) del VKR, utilizzando due bulloni esagonali M10X75mm (99), quattro rondelle M10 (112) e due dadi in nylon M10 (117). Fissare i due tubi dell'impugnatura (15) al VKR destro e sinistro (33&34), utilizzando

Fissare i due tubi dell'impugnatura (15) al VKR destro e sinistro (33&34), utilizzando due bulloni esagonali M10X20mm (104) e due rondelle M10 (112).

Fissare il cuscino dello schienale (46) al telaio inferiore di supporto VKR (31) e al telaio superiore di supporto VKR (32), utilizzando due bulloni esagonali M8X65mm (106) e due rondelle M8 (114). Fissare i due cuscini del braccio VKR (50) al VKR destro e sinistro (33&34), utilizzando quattro bulloni esagonali M8X65mm (106) e quattro rondelle M8 (114).

# INSTALLAZIONE DEI CAVI

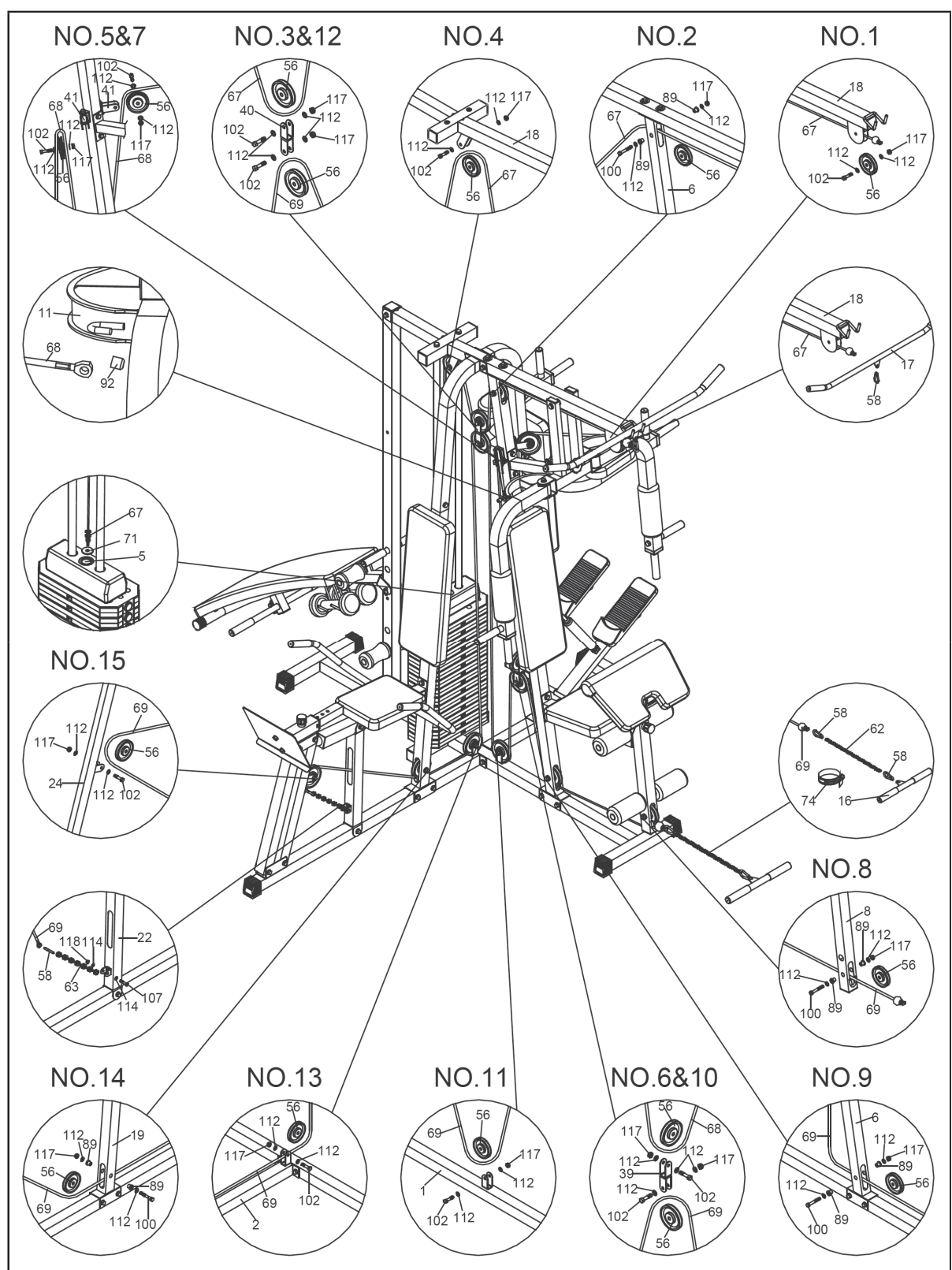



### Iniziare con il cavo superiore (67)

- (a) Con cavo superiore (67) nella scanalatura della puleggia (56), filettare il cavo superiore (67) attraverso la traversa superiore (18).
- (b) Installare la puleggia n. 1 (56) alla traversa superiore (18), utilizzando un bullone esagonale M10X45mm (102), due rondelle M10 (112) e un dado in nylon M10 (117).
- (c) Installare la puleggia n. 2 (56) e due boccole (piccole) (89) al telaio di supporto (6), utilizzando un bullone esagonale M10X70mm (100), due rondelle M10 (112) e un dado in nylon M10 (117).
- (d) Installare la puleggia n. 4 (56) alla traversa superiore (18), utilizzando un bullone esagonale M10X45mm (102), due rondelle M10 (112) e un dado in nylon M10 (117).
- (e) Fissare l'estremità del bullone del cavo superiore (67) all'albero di selezione (5) con rondella in plastica (71).
- (f) Installare la puleggia n. 3 (56) sulla puleggia U (40), utilizzando un bullone esagonale M10X45mm (102), due rondelle M10 (112) e un dado in nylon M10 (117).
- (g) Fissare la barra di chiusura (17) all'altra estremità del cavo superiore (67), utilizzando un Pothook (58).

### 2. Assemblaggio del cavo a farfalla (68)

- (a) Collegare entrambe le estremità del cavo a farfalla (68) al braccio a farfalla destro e sinistro (11 e 12), utilizzando due coperchi in plastica (92).
- (b) Installare la puleggia n. 5&7 (56) a due blocchi di pulegge singole (41), utilizzando due bulloni esagonali M10X45mm (102), quattro rondelle M10 (112) e due dadi in nylon M10 (117).
- (c) Installare la puleggia n. 6 (56) per invertire U (39), utilizzando un bullone esagonale M10X45mm (102), due rondelle M10 (112) e un dado in nylon M10 (117).

### 3. Montaggio del cavo inferiore (69)

- (a) Con il cavo inferiore (69) nella scanalatura della puleggia (56) attraverso il telaio di prolunga gambe (8).
- (b) Installare la puleggia n. 8 (56) e due boccole (piccole) (89) sul telaio di estensione delle gambe (8), utilizzando un bullone esagonale M10X70mm (100), due rondelle M10 (112) e un dado in nylon M10 (117).
- (c) Installare la puleggia n. 9 (56) e due boccole (piccole) (89) al telaio di supporto (6), utilizzando un bullone esagonale M10X70mm (100), due rondelle M10 (112) e un dado in nylon M10 (117).
- (d) Installare la puleggia n. 10 (56) per invertire U (39), utilizzando un bullone esagonale M10X45mm (102), due rondelle M10 (112) e un dado in nylon M10 (117).
- (e) Installare la puleggia n. 11 (56) al telaio di base (1), utilizzando un bullone esagonale M10X45mm (102), due rondelle M10 (112) e un dado in nylon M10 (117).
- (f) Installare la puleggia n. 12 (56) sulla puleggia U (40), utilizzando un bullone esagonale M10X45mm (102), due rondelle M10 (112) e un dado in nylon M10 (117).
- (g) Installare la puleggia n. 13 (56) al telaio della base della gamba (2), utilizzando un bullone esagonale M10X45mm (102), due rondelle M10 (112) e un dado in nylon M10 (117).
- (h) Installare la puleggia n. 14 (56) e due boccole (piccole) (89) sul telaio di supporto inferiore della pressa gambe (19), utilizzando un bullone esagonale M10X70mm (100), due rondelle M10 (112) e un dado in nylon M10 (117).
- (i) Installare la puleggia n. 15 (56) al telaio verticale della pressa gambe posteriori (24), utilizzando un bullone esagonale M10X45mm (102), due rondelle M10 (112) e un dado in nylon M10 (117).
- (j) Fissare l'estremità del bullone del cavo inferiore (69) al telaio di supporto della sede pressa gambe (22), utilizzando un gancio (58), una catena corta (63), un bullone esagonale M8X40mm (107), due rondelle M8 (114) e un dado in nylon M8 (118).
- (k) Fissare la barra bassa (16) o la cinghia alla caviglia (74) all'altra estremità del cavo inferiore (69), utilizzando una catena lunga (62) e due ganci a pressione (58).

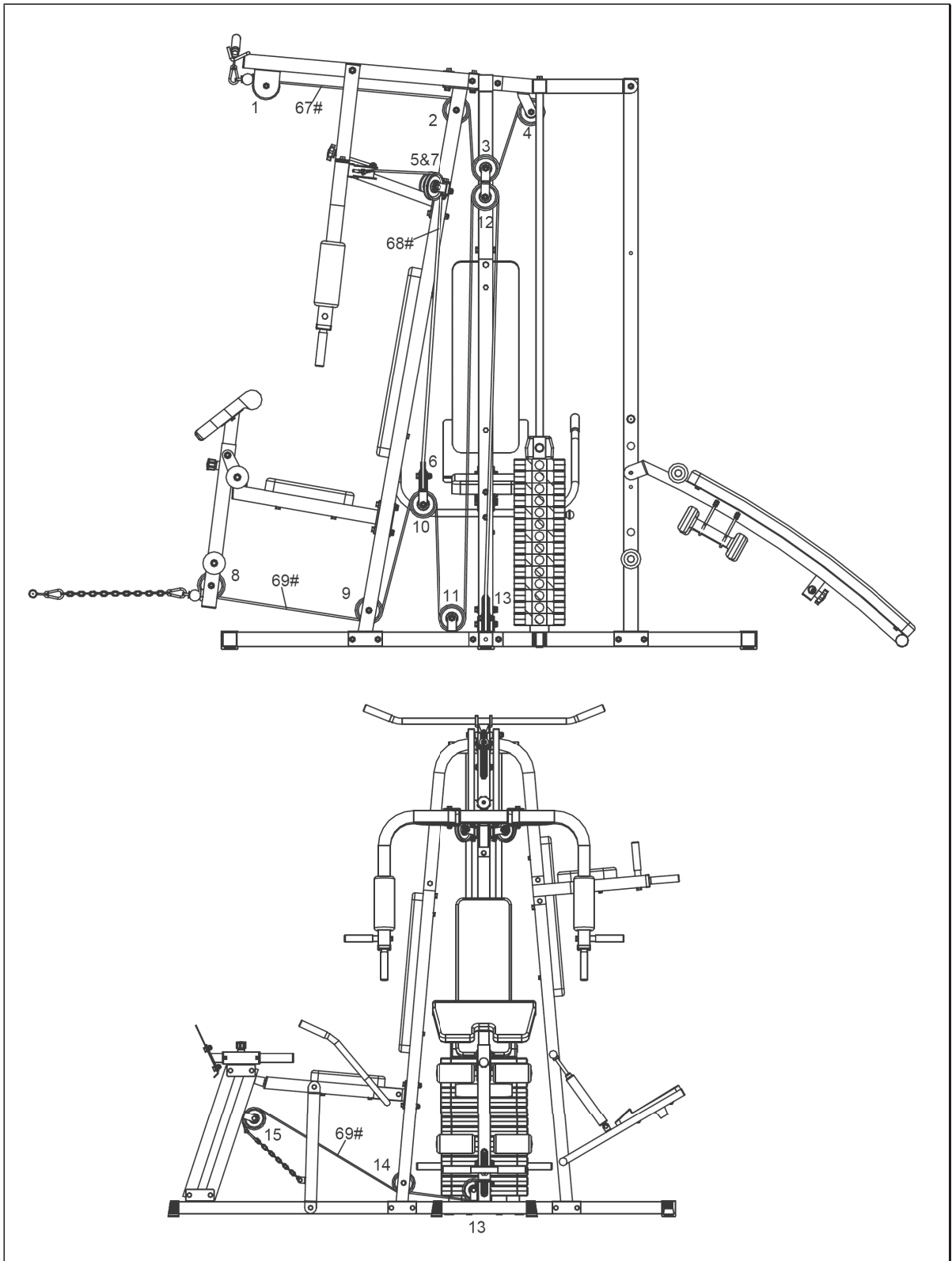

## RISCALDAMENTO PRIMA DELL'ALLENAMENTO

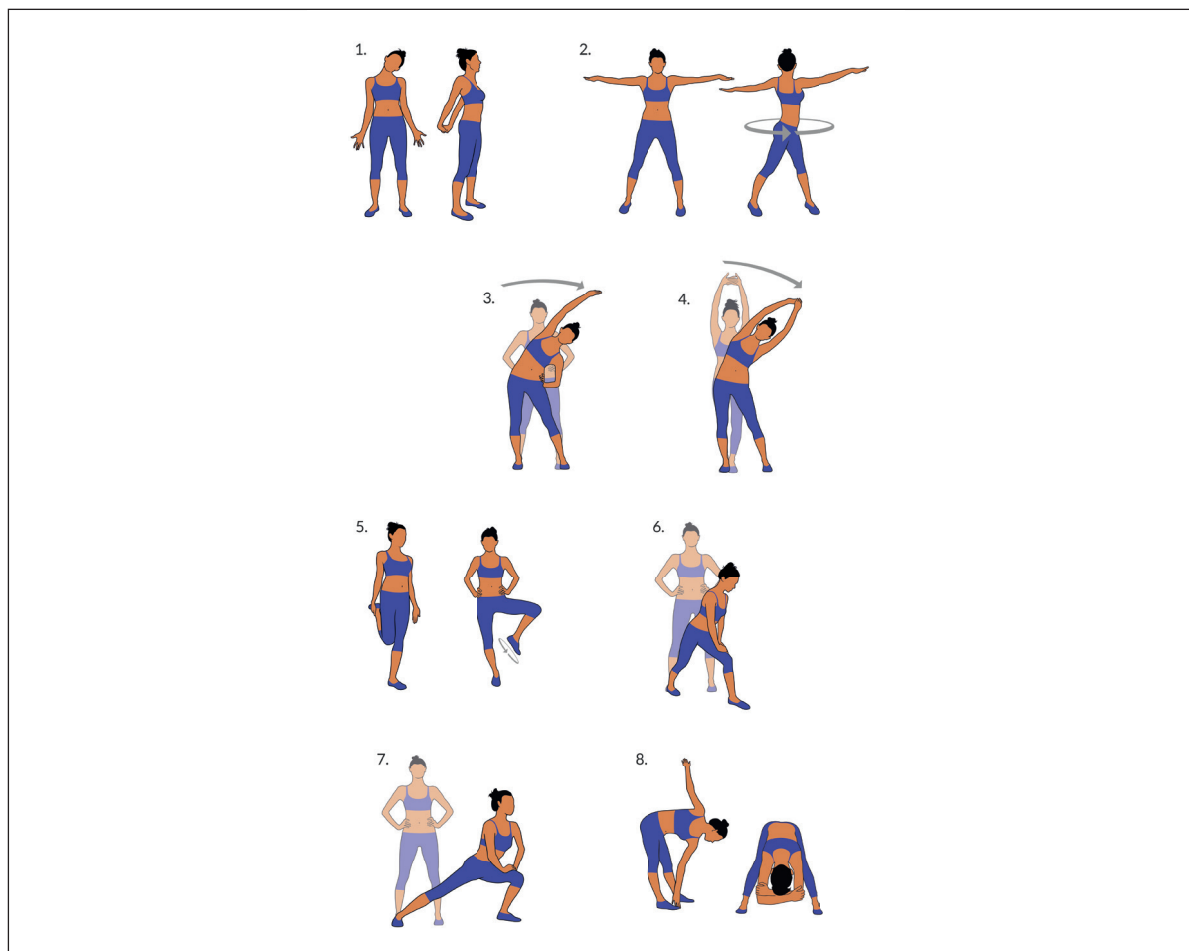

Eeguire gli esercizi di riscaldamento prima di ogni sessione di allenamento. In questo modo verranno mobilitate le articolazioni e attivati i muscoli.

Se durante movimenti singoli dovessero sorgere sensazioni di malessere o dolori, saltare l'esercizio in questione e concordare un riscaldamento specifico con il medico o il personal trainer.

Ogni movimento deve essere ripetuto diverse volte (a destra e a sinistra) in modo da poter realizzare un allenamento cardio in modo rilassato.

### Calcolare circa 5 minuti per la seguente routine di allenamento Klarfit:

1. Piegarne lentamente la testa lateralmente, alternando a destra e sinistra. In seguito mobilitare le spalle (movimenti circolari e alzando e abbassando le spalle).
2. Ruotare i fianchi con le braccia distese. I piedi non devono essere fissi al suolo (le caviglie accompagnano la rotazione del corpo).
3. Piegarne i fianchi, un braccio disteso verso l'alto. Mantenere questa posizione per alcuni secondi per ogni lato.
4. Piegarne i fianchi con entrambe le braccia verso l'alto, tenendo le mani unite. Anche in questo caso mantenere la posizione per ogni lato. Questo esercizio è leggermente più intenso, dato che anche il secondo braccio esercita tensione.
5. Posizionarsi su una gamba e mantenere la tensione della gamba piegata con la mano. In tal modo si mobilita la caviglia e si distende leggermente la coscia. Se necessario, appoggiarsi in modo da non perdere l'equilibrio. Rimanere su una gamba e ruotare la caviglia in entrambe le direzioni.
6. Allungare una gamba in avanti e appoggiarsi con il busto sulla coscia. In tal modo si mobilitano ginocchio, caviglia e polpaccio.
7. Ripetere l'esercizio al punto 6, ma distendendo maggiormente la gamba in avanti. Il movimento risulta più intenso.
8. Piegarne in avanti con le gambe divaricate e toccare alternativamente con la mano il piede sullo stesso lato. Infine lasciar cadere in avanti il busto in modo rilassato.









