



blumfeldt

Tahiti

Hollywoodschaukel

Swing Chair

Balancelle

Dondolo Hollywood

Columpio para jardín

100290200 10033575



Sehr geehrter Kunde,

wir gratulieren Ihnen zum Erwerb Ihres Gerätes. Lesen Sie die folgenden Hinweise sorgfältig durch und befolgen Sie diese, um möglichen Schäden vorzubeugen. Für Schäden, die durch Missachtung der Hinweise und unsachgemäßen Gebrauch entstehen, übernehmen wir keine Haftung. Scannen Sie den folgenden QR-Code, um Zugriff auf die aktuellste Bedienungsanleitung und weitere Informationen rund um das Produkt zu erhalten:

**Dear Customer,**

Congratulations on purchasing this device. Please read the following instructions carefully and follow them to prevent possible damages. We assume no liability for damage caused by disregard of the instructions and improper use. Scan the QR code to get access to the latest user manual and more product information.

**Estimado cliente,**

Le felicitamos por la adquisición de este producto. Lea atentamente las siguientes instrucciones y sígalas para evitar posibles daños. No asumimos ninguna responsabilidad por los daños causados por el incumplimiento de las instrucciones y el uso inadecuado. Escanee el siguiente código QR para obtener acceso a la última guía del usuario y más información sobre el producto.

**Chère cliente, cher client,**







Toutes nos félicitations pour l'acquisition de ce nouvel appareil. Veuillez lire attentivement et respecter les instructions de ce mode d'emploi afin d'éviter d'éventuels dommages. Nous ne saurions être tenus pour responsables des dommages dus au non-respect des consignes et à la mauvaise utilisation de l'appareil. Scannez le QR-Code pour obtenir la dernière version du mode d'emploi et des informations supplémentaires concernant le produit.



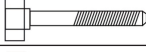
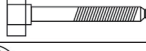
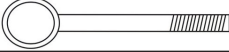

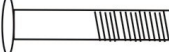
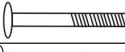

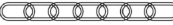





**Gentile cliente,**

La ringraziamo per aver acquistato il dispositivo. La preghiamo di leggere attentamente le seguenti istruzioni per l'uso e di seguirle per evitare possibili danni. Non ci assumiamo alcuna responsabilità per danni scaturiti da una mancata osservazione delle avvertenze di sicurezza e da un uso improprio del dispositivo. Scansionare il codice QR seguente, per accedere al manuale d'uso più attuale e per ricevere informazioni sul prodotto.

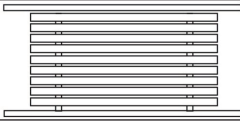











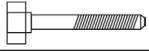
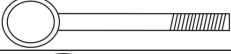

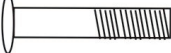
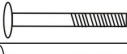





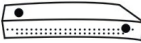

LIEFERUMFANG

A		Schraube	M10 x 190 mm	x4
B		Schraube	M10 x 100 mm	x4
C		Schraube	M10 x 100 mm	x4
D		Schraubhaken	M10 x 110 mm	x2
E		Schraubhaken	M10 x 60 mm	x4
F		Bolzenkappe		x12
G		Gewindebolzen	M8 x 60 mm	x8
H		Gewindebolzen	M6 x 40 mm	x12
I		Gewindebolzen	M8 x 80 mm	x4
J		Kette (lang)		x2
K		Kette (kurz)		x2
L		Mutter		x14

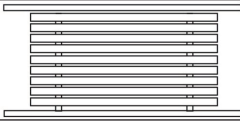









M		Unterlegscheibe	x28
O		Karabiner	x6
P		Fuß	x4
Q		Bogentraverse	x1
R		Strebe oben	x2
S		Strebe unten	x2
T		Sitzfläche	x1
U		Dach-Streben, quer	x6
V		Dach-Streben, längs	x2
W		Armlehnen	x2
X		Inbusschlüssel	x3
Y		Schlüssel, Griff	x2

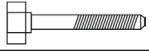
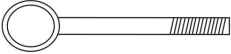



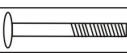
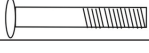





SCOPE OF DELIVERY

A		Screw	M10 x 190 mm	x4
B		Screw	M10 x 100 mm	x4
C		Screw	M10 x 100 mm	x4
D		Screw hook	M10 x 110 mm	x2
E		Screw hook	M10 x 60 mm	x4
F		Bolt cap		x12
G		Threaded bolt	M8 x 60 mm	x8
H		Threaded bolt	M6 x 40 mm	x12
I		Threaded bolt	M8 x 80 mm	x4
J		Chain (long)		x2
K		Chain (short)		x2
L		Nut		x14



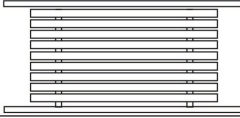
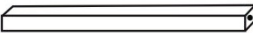





M		Washer	x28
O		Carabiner	x6
P		Base	x4
Q		Arch truss	x1
R		Upper strut	x2
S		Lower strut	x2
T		Seat	x1
U		Roof struts, transverse	x6
V		Roof struts, longitudinal	x2
W		Armrests	x2
X		Allen key	x3
Y		Key, handle	x2

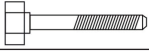
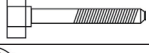
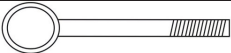



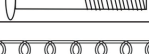





CONTENIDO DEL ENVÍO

A		Tornillo	M10 x 190 mm	x4
B		Tornillo	M10 x 100 mm	x4
C		Tornillo	M10 x 100 mm	x4
D		Gancho de tornillo	M10 x 110 mm	x2
E		Gancho de tornillo	M10 x 60 mm	x4
F		Tapón para perno		x12
G		Perno roscado	M8 x 60 mm	x8
H		Perno roscado	M6 x 40 mm	x12
I		Perno roscado	M8 x 80 mm	x4
J		Cadena (larga)		x2
K		Cadena (corta)		x2
L		Tuerca		x14

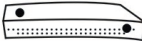

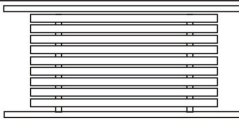
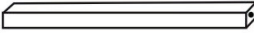





M		Arandela	x28
O		Mosquetón	x6
P		Pata	x4
Q		Arco transversal	x1
R		Puntal superior	x2
S		Puntal inferior	x2
D		Asiento	x1
U		Puntal de techo, transversal	x6
V		Puntal de techo, longitudinal	x2
W		Reposabrazos	x2
X		Llave Allen	x3
Y		Llave, asa	x2



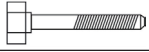
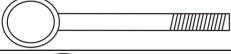

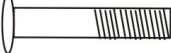
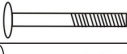





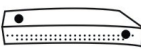

CONTENU DE L'EMBALLAGE

A		Vis	M10 x 190 mm	x4
B		Vis	M10 x 100 mm	x4
C		Vis	M10 x 100 mm	x4
D		Crochet à vis	M10 x 110 mm	x2
E		Crochet à vis	M10 x 60 mm	x4
F		Cache boulon		x12
G		Boulon fileté	M8 x 60 mm	x8
H		Boulon fileté	M6 x 40 mm	x12
I		Boulon fileté	M8 x 80 mm	x4
J		Chaîne (longue)		x2
K		Chaîne (courte)		x2
L		Écrou		x14

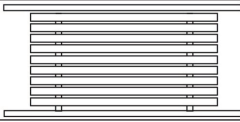
M		Rondelle	x28
O		Mousqueton	x6
P		Pied	x4
Q		Voûte	x1
R		Traverse supérieure	x2
C		Traverse inférieure	x2
F		Assise	x1
U		Traverses de toit latérales	x6
V		Traverses de toit longitudinales	x2
W		Accoudoir	x2
X		Clé Allen	x3
Y		Clé, poignée	x2

VOLUME DI CONSEGNA

A		Vite	M10 x 190 mm	x4
B		Vite	M10 x 100 mm	x4
C		Vite	M10 x 100 mm	x4
D		Gancio a vite	M10 x 110 mm	x2
E		Gancio a vite	M10 x 60 mm	x4
F		Tappo per i bulloni		x12
G		Bullone filettato	M8 x 60 mm	x8
H		Bullone filettato	M6 x 40 mm	x12
I		Bullone filettato	M8 x 80 mm	x4
J		Catena (lunga)		x2
K		Catena (corta)		x2
L		Dado		x14

M		Rondella	x28
O		Moschettone	x6
P		Base	x4
Q		Traversa ad arco	x1
R		Supporto superiore	x2
A		Supporto inferiore	x2
D		Superficie di seduta	x1
U		Supporto del tetto, trasversale	x6
V		Supporto del tetto, in lunghezza	x2
W		Braccioli	x2
X		Chiave a brugola	x3
Y		Chiave, impugnatura	x2

ZUSAMMENBAU

Assembly | Ensamblaje | Assemblée | Assemblaggio

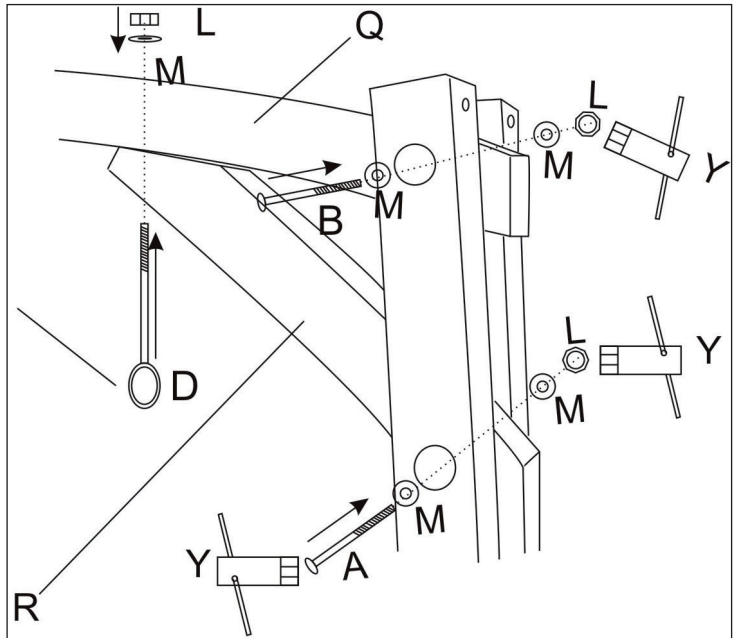

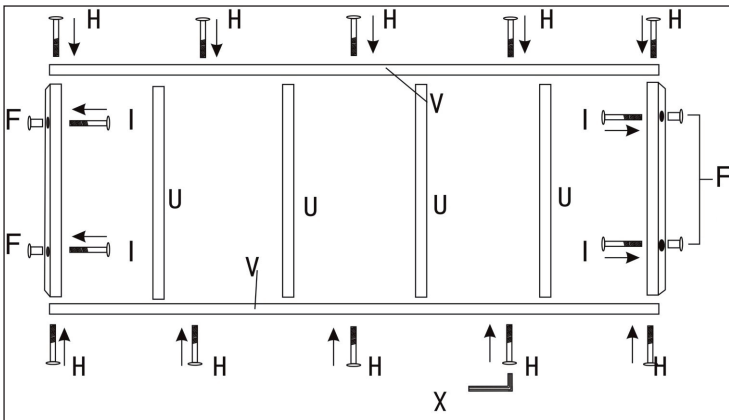
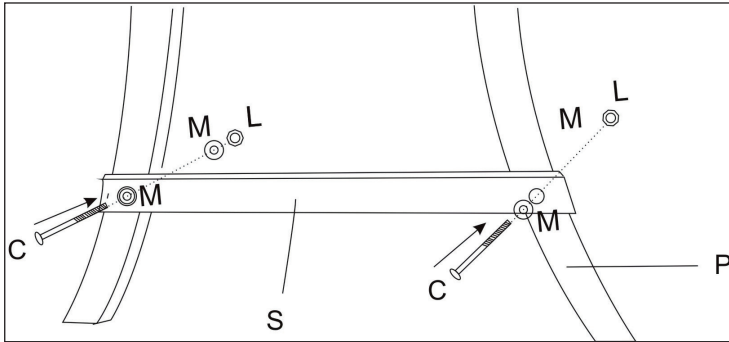

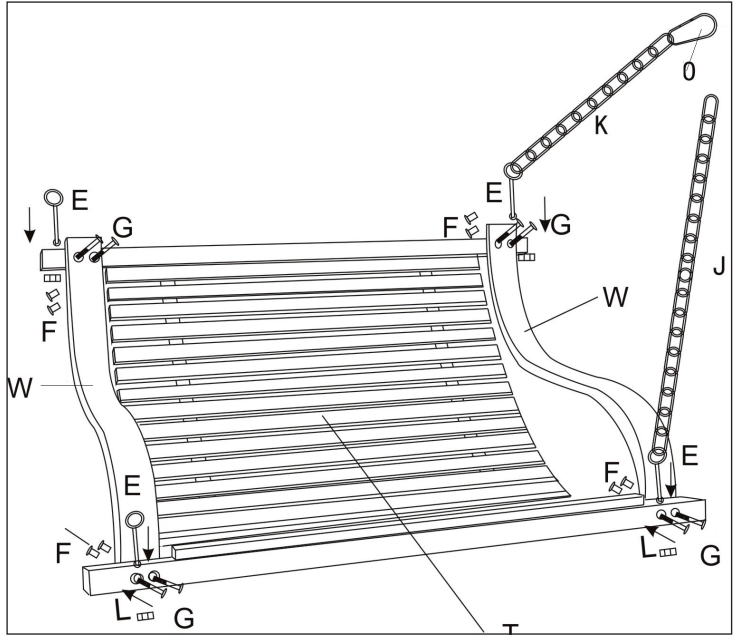

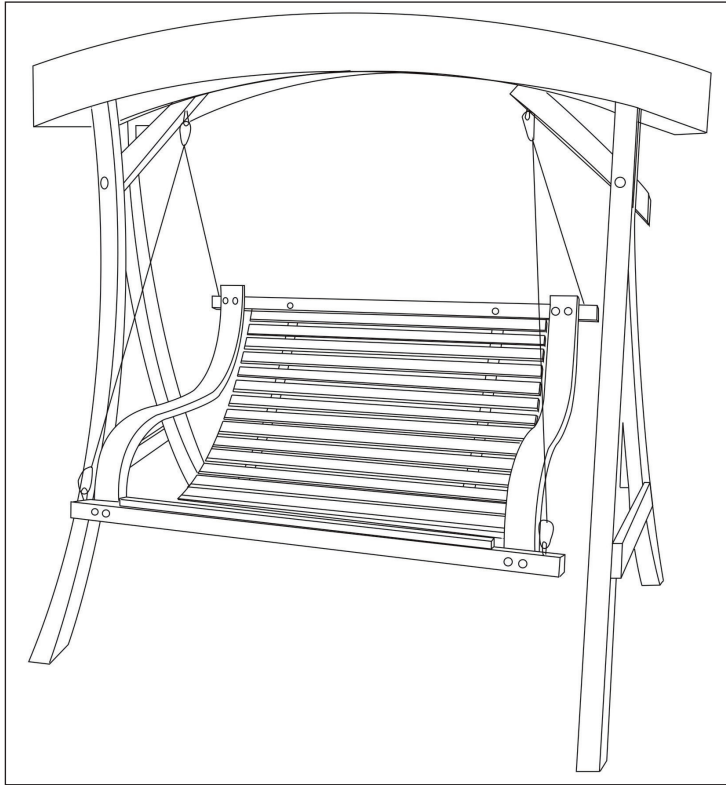

HERSTELLER

Manufacturer | Fabricante | Fabricant | Produttore

Chal-Tec GmbH, Wallstraße 16, 10179 Berlin, Deutschland (Germany).

IMPORTEUR FÜR GROSSBRITANNIEN

Importer for Great Britain | Importador para Gran Bretaña | Importateur pour la Grande Bretagne | Importatore per la Gran Bretagna

Berlin Brands Group UK Limited
PO Box 42
272 Kensington High Street
London, W8 6ND
United Kingdom

