



blumfeldt

## **Altiplano Cubic**

Hochbeet

Raised Bed

Maceta elevada

Platebande surélevée

Vaso rialzato

10033605





**Sehr geehrter Kunde,**

wir gratulieren Ihnen zum Erwerb Ihres Gerätes. Lesen Sie die folgenden Hinweise sorgfältig durch und befolgen Sie diese, um möglichen Schäden vorzubeugen. Für Schäden, die durch Missachtung der Hinweise und unsachgemäßen Gebrauch entstehen, übernehmen wir keine Haftung. Scannen Sie den folgenden QR-Code, um Zugriff auf die aktuellste Bedienungsanleitung und weitere Informationen rund um das Produkt zu erhalten.

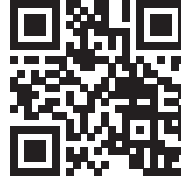
**Dear Customer,**

Congratulations on purchasing this device. Please read the following instructions carefully and follow them to prevent possible damages. We assume no liability for damage caused by disregard of the instructions and improper use. Scan the QR code to get access to the latest user manual and more product information.

**Estimado cliente,**

Le felicitamos por la adquisición de este producto. Lea atentamente las siguientes instrucciones y sígalas para evitar posibles daños. No asumimos ninguna responsabilidad por los daños causados por el incumplimiento de las instrucciones y el uso inadecuado. Escanee el siguiente código QR para obtener acceso a la última guía del usuario y más información sobre el producto.

**Chère cliente, cher client,**

Toutes nos félicitations pour l'acquisition de ce nouvel appareil. Veuillez lire attentivement et respecter les instructions de ce mode d'emploi afin d'éviter d'éventuels dommages. Nous ne saurions être tenus pour responsables des dommages dus au non-respect des consignes et à la mauvaise utilisation de l'appareil. Scannez le QR-Code pour obtenir la dernière version du mode d'emploi et des informations supplémentaires concernant le produit.

**Gentile cliente,**

La ringraziamo per aver acquistato il dispositivo. La preghiamo di leggere attentamente le seguenti istruzioni per l'uso e di seguirle per evitare possibili danni. Non ci assumiamo alcuna responsabilità per danni scaturiti da una mancata osservazione delle avvertenze di sicurezza e da un uso improprio del dispositivo. Scansionare il codice QR seguente, per accedere al manuale d'uso più attuale e per ricevere informazioni sul prodotto.



# LIEFERUMFANG

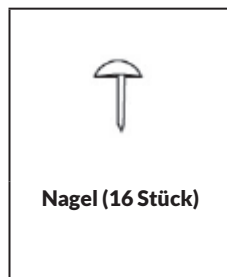
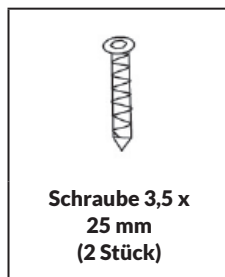
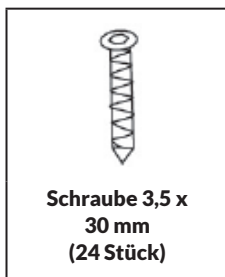
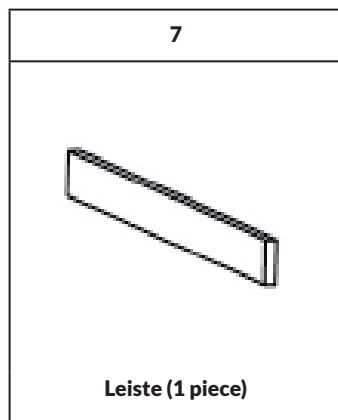
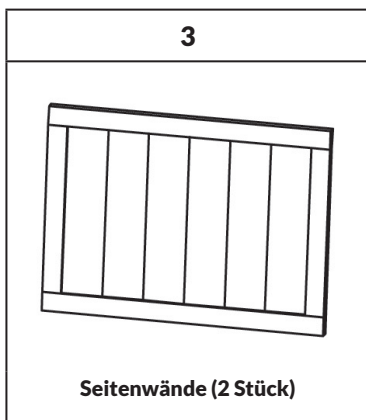
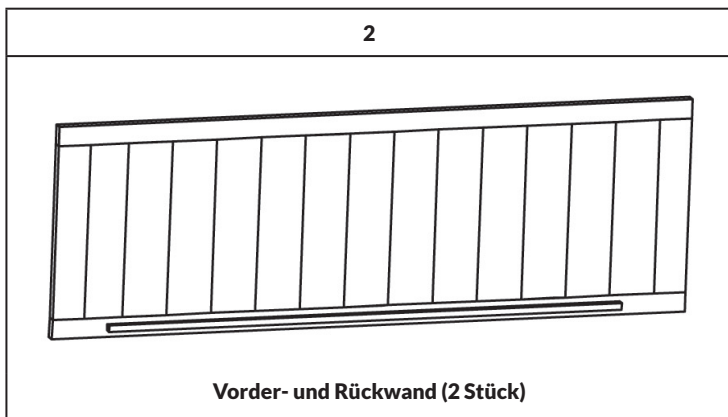
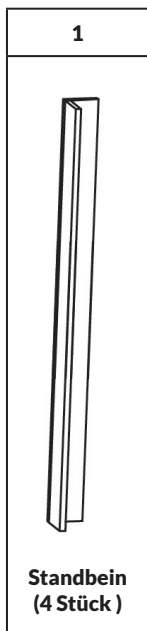

4

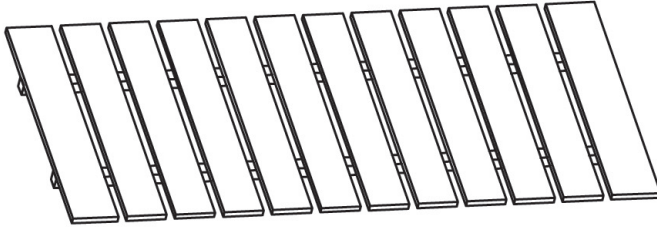
**Boden (1 Stück)**

5

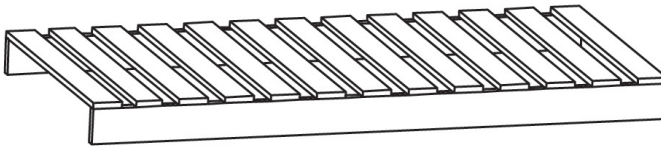
**Ablage (1 Stück)**

6

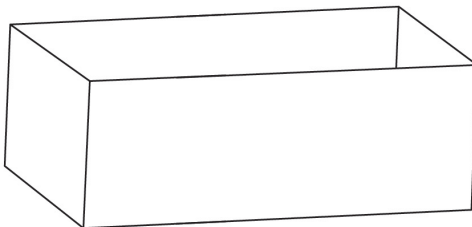
**Innenteil (1 Stück)**

## MONTAGE

### Schritt 1:

Montieren Sie die Vorder- und Rückwand (2) und die Seitenwände (3) am oberen Ende der 4 Standbeine (1) und schrauben Sie diese mit 16 Schrauben (3,5 mm x 30 mm) fest.

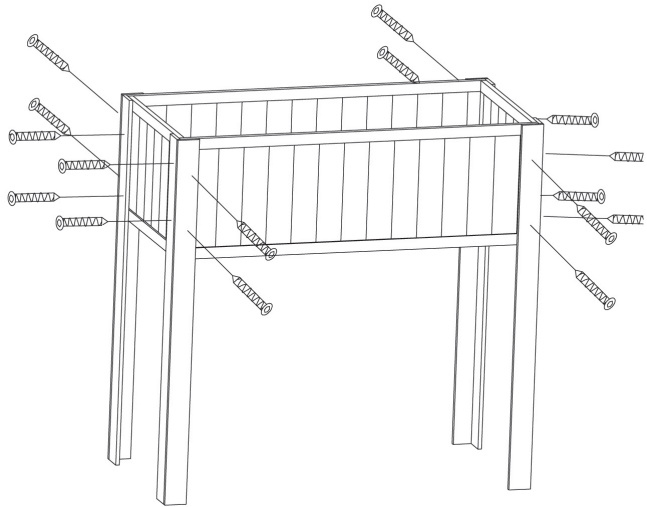

**Schrauben 3,5 x 30 mm (16 Stück)**

**Schritt 2:**

Montieren Sie die Ablage (5) im unteren Bereich der vier Standbeine (1) und schrauben Sie diese mit 8 Schrauben (3,5 mm x 30 mm) fest.

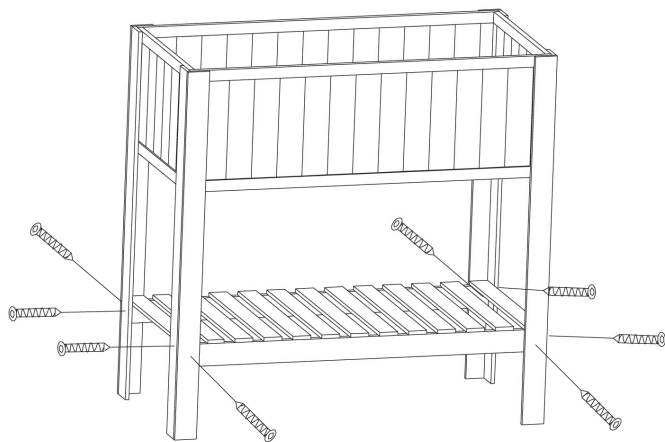

**Schrauben 3,5 x 30 mm (8 Stück)**

**Schritt 3:**

Legen Sie nun den Boden (4) von oben in das Hochbeet hinein.

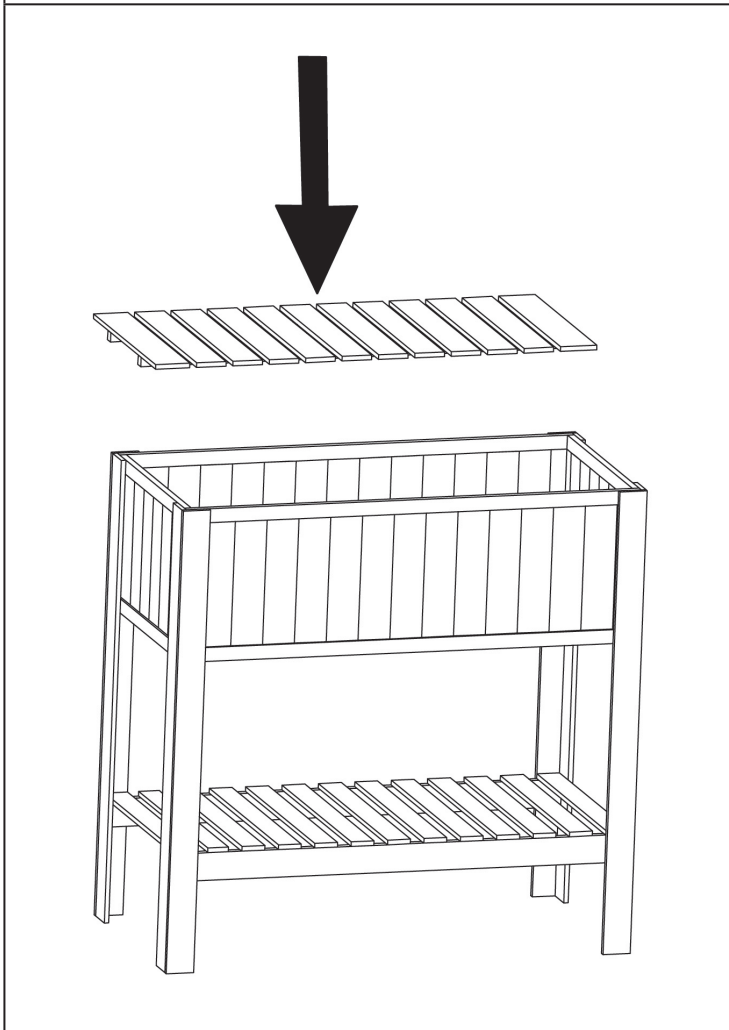



**Schritt 4:**

Befestigen Sie den Boden (4) mit der Leiste (7) von unten mit 2 Schrauben (3,5 mm x 25 mm) am Hochbeet.

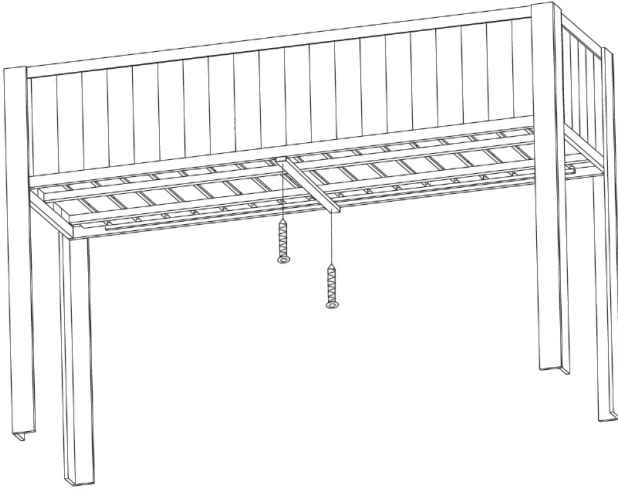

**Schrauben 3,5 x 25 mm (2 Stück)**

**Schritt 5:**

Befestigen Sie das Innenteil (6) mit 16 Nägeln im Hochbett.

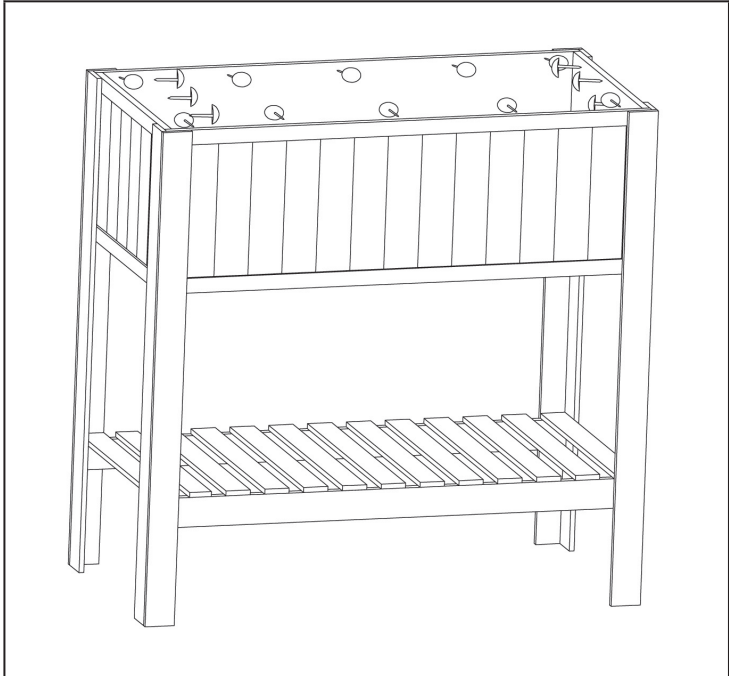

**Ihr Hochbett ist nun fertig montiert und einsatzbereit.**

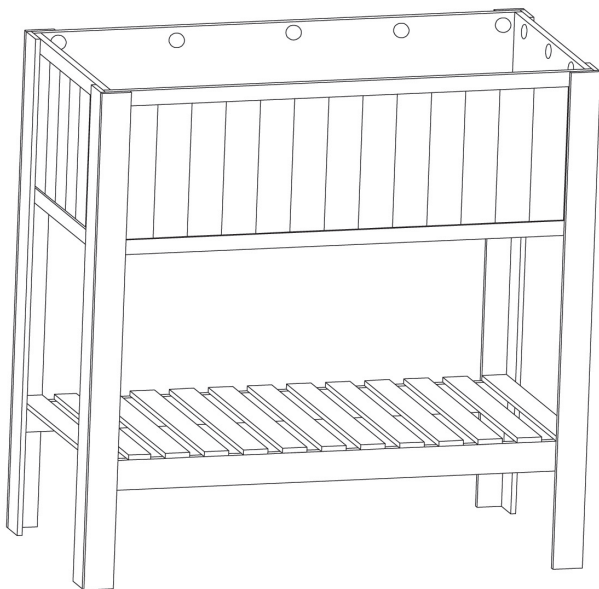

## SCOPE OF DELIVERY

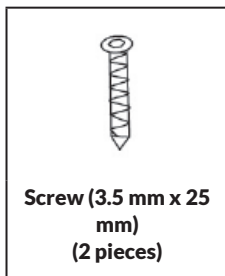
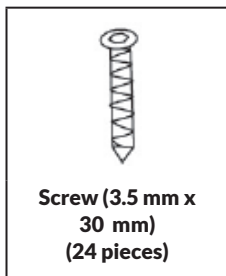
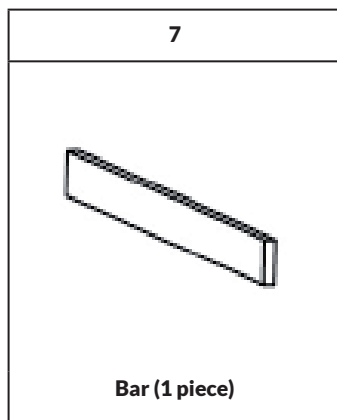
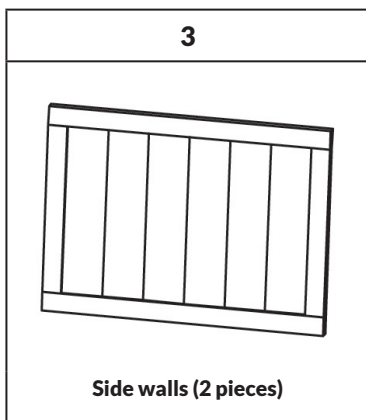
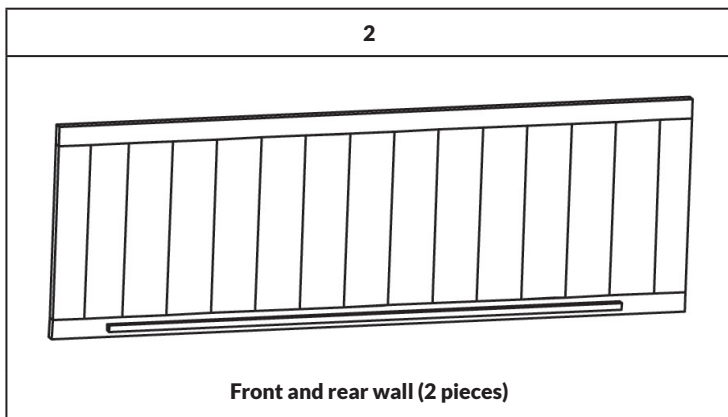
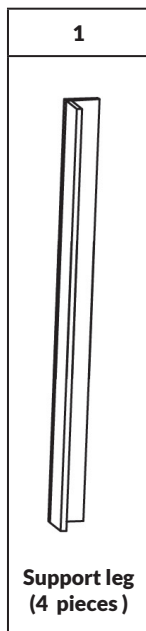

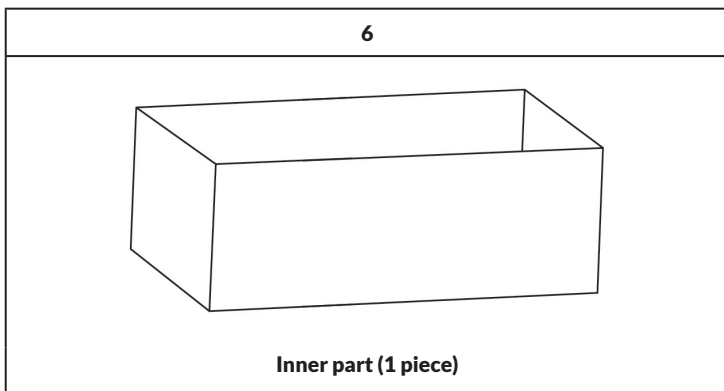
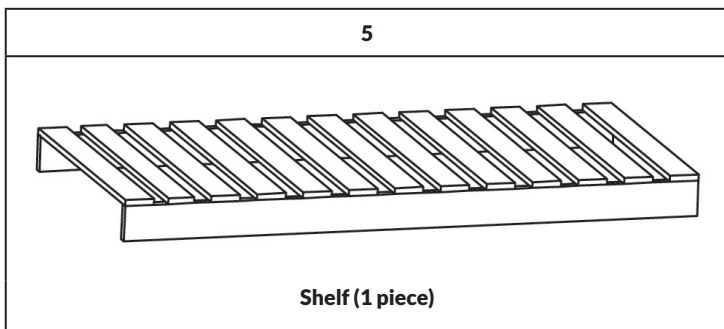
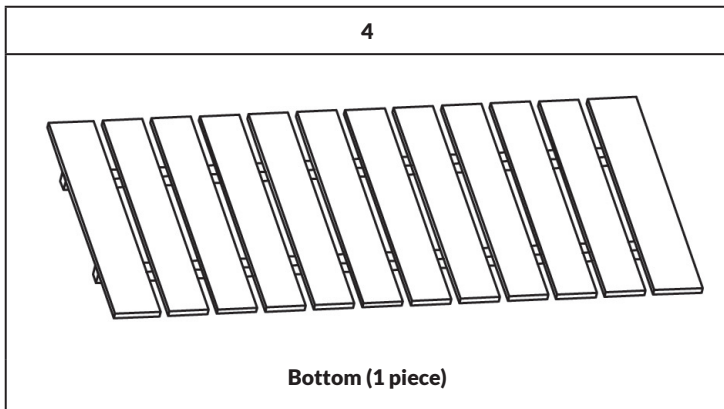

## ASSEMBLY

### Step 1:

Assemble the front and rear panels (2) and the side panels (3) to the upper end of the 4 support legs (1) and screw them tight with 16 screws (3.5 mm x 30 mm).

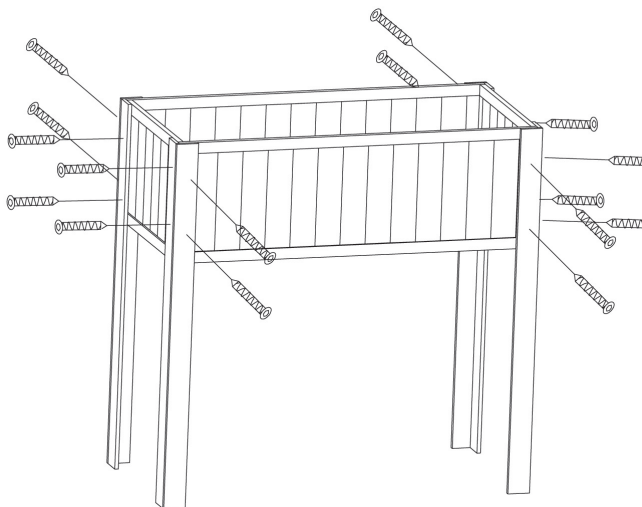

**Screws 3.5 x 30 mm (16 pieces)**

**Step 2:**

Mount the shelf (5) in the lower area of the four support legs (1) and screw it tight with 8 screws (3.5 mm x 30 mm).

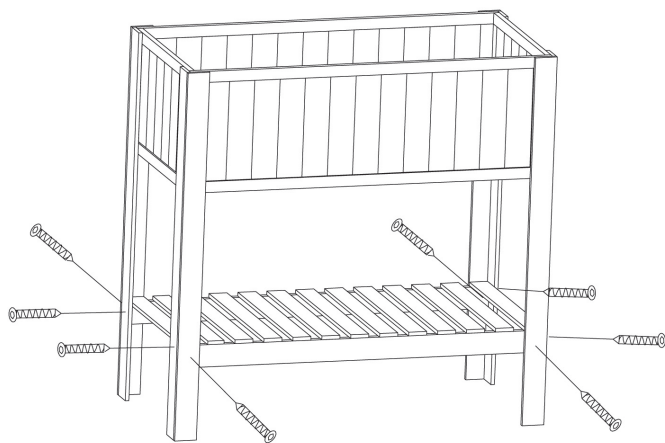

**Screws 3.5 x 30 mm (8 pieces)**

**Step 3:**

Now place the bottom (4) from above into the raised bed.

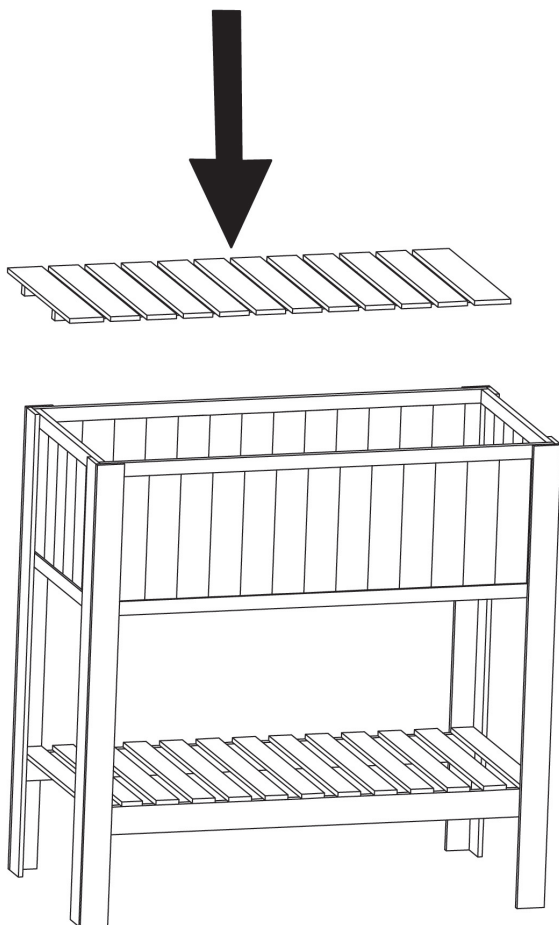



**Step 4:**

Fasten the bottom (4) with the bar (7) to the raised bed from below with 2 screws (3.5 mm x 25 mm).

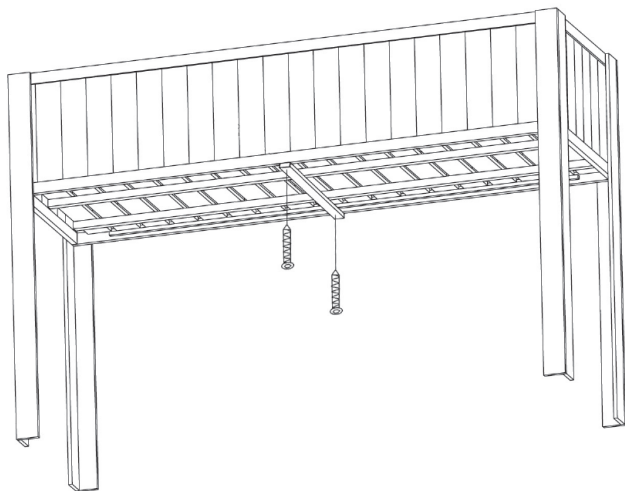

**Screws 3.5 x 25 mm (2 pieces)**

**Step 5:**

Fasten the inner part (6) to the raised bed with 16 nails.

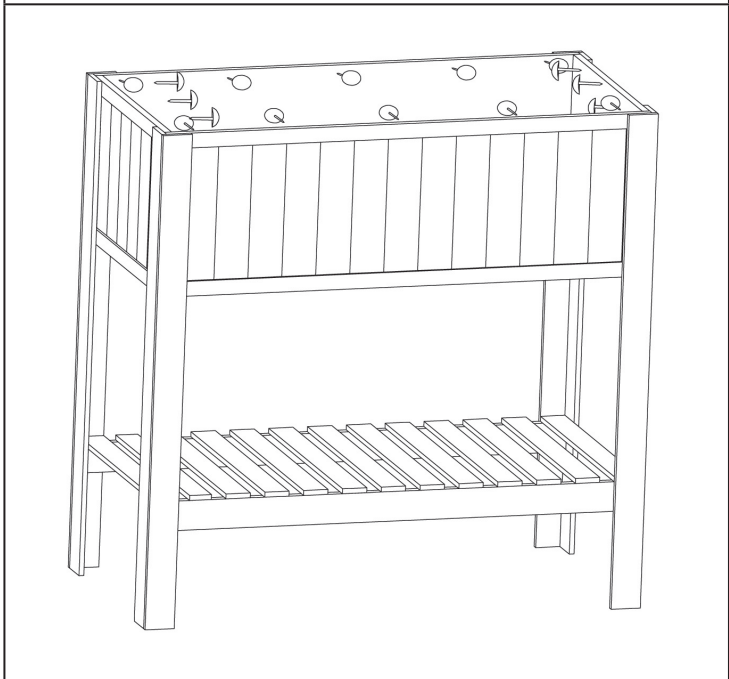

**Your raised bed is now fully assembled and ready for use.**

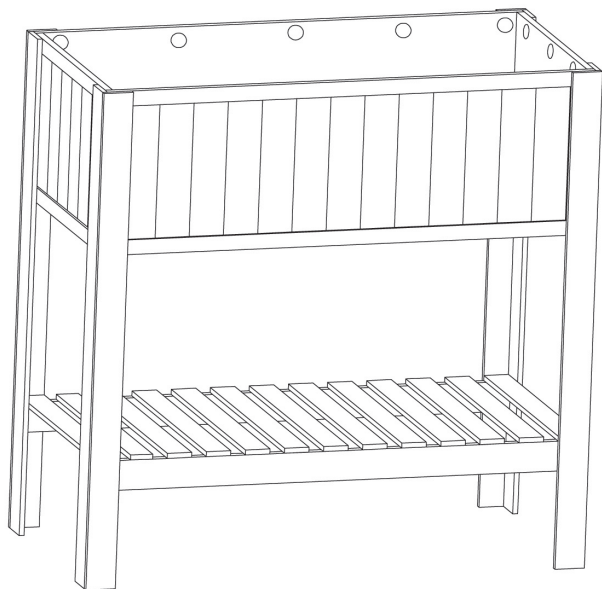

## CONTENIDO DEL ENVÍO

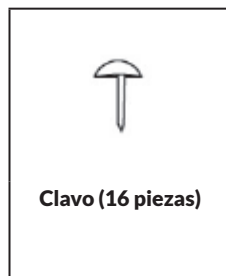
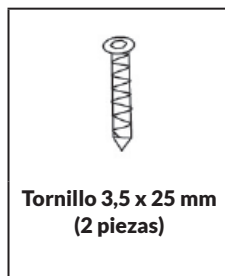
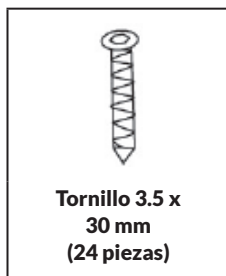
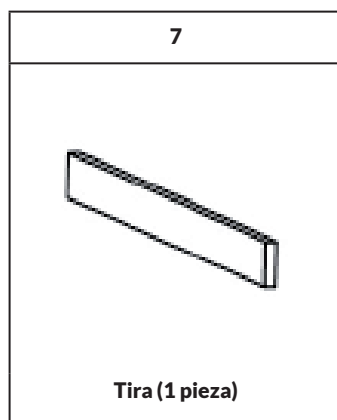
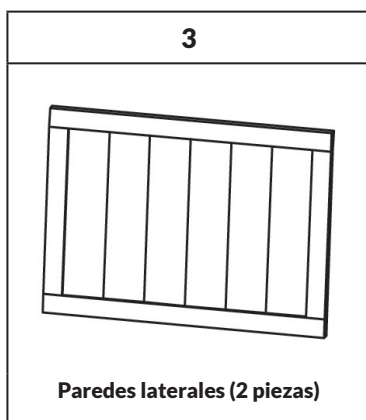
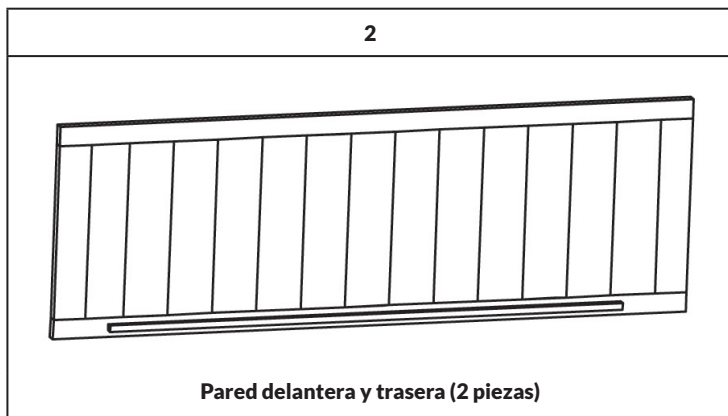
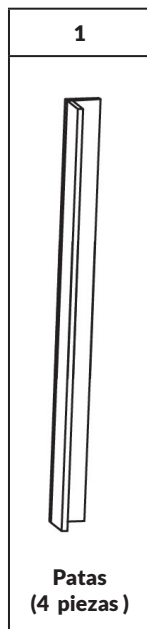

4

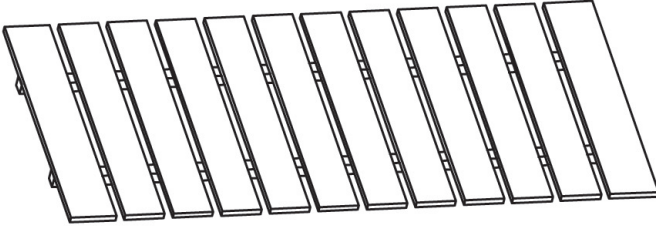
**Suelo (1 pieza)**

5

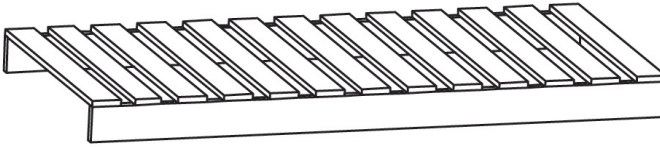
**Estante (1 pieza)**

6

**Parte interior (1 pieza)**

# MONTAJE

**Paso 1:**

Monte los paneles frontal y trasero (2) y los paneles laterales (3) en la parte superior de las 4 patas (1) y atorníllelos con 16 tornillos (3,5 mm x 30 mm).

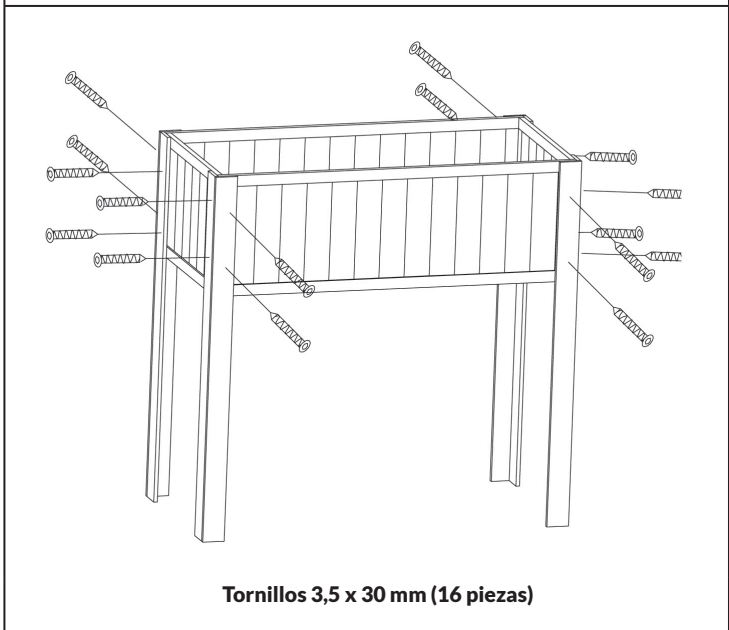

**Paso 2:**

Monte el estante (5) en la parte inferior de las cuatro patas (1) y atorníllelo con 8 tornillos (3,5 mm x 30 mm).

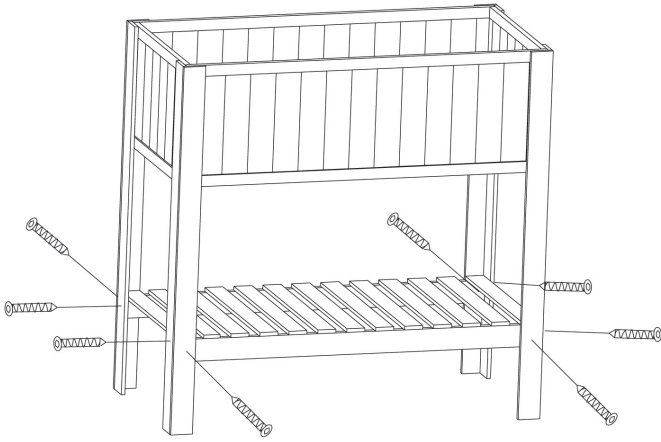

**Tornillos 3,5 x 30 mm (8 piezas)**

**Paso 3:**

Ahora coloque el fondo (4) en la cama elevada desde arriba.

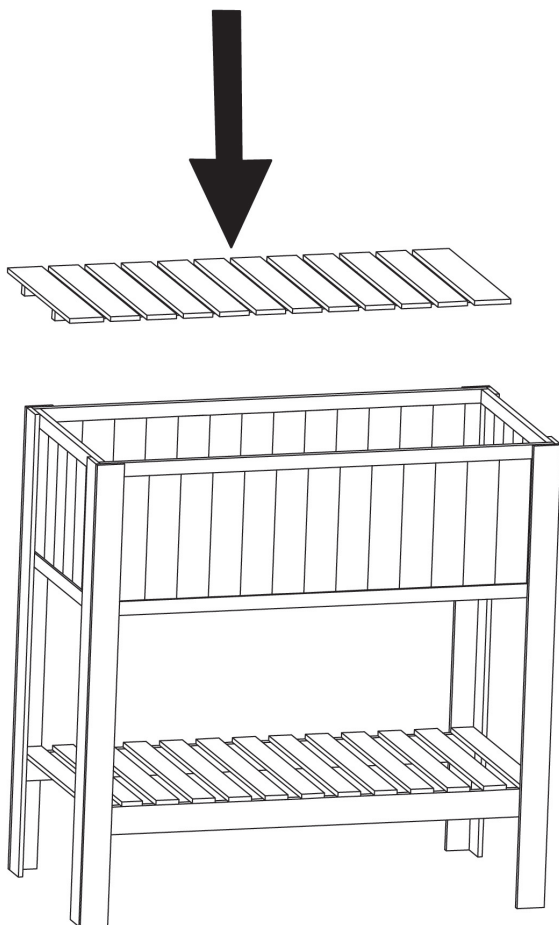



**Paso 4:**

Fije el fondo (4) a la cama elevada desde abajo con el listón (7) utilizando 2 tornillos (3,5 mm x 25 mm).

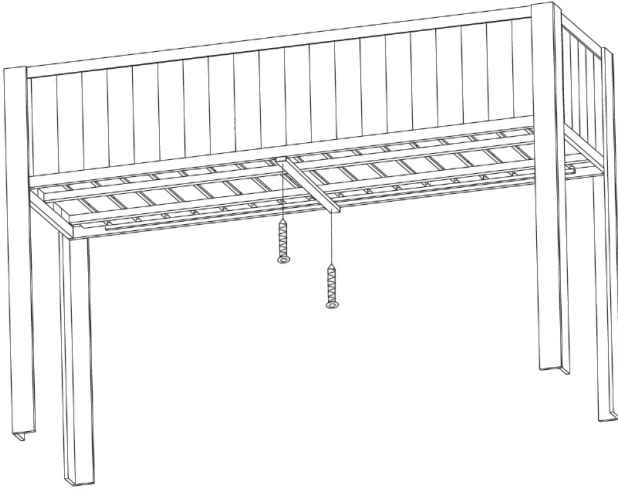

**Tornillos 3,5 x 25 mm (2 piezas)**

**Paso 5:**

Su lecho elevado está ahora completamente montado y listo para su uso.

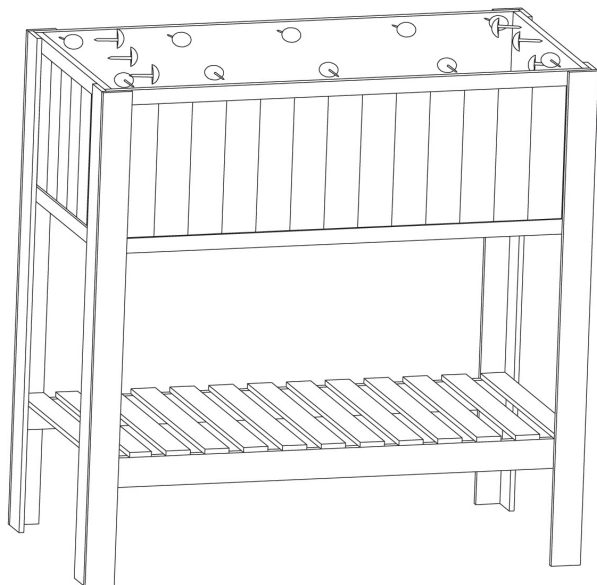

**La cama elevada ya está montada y lista para usar.**

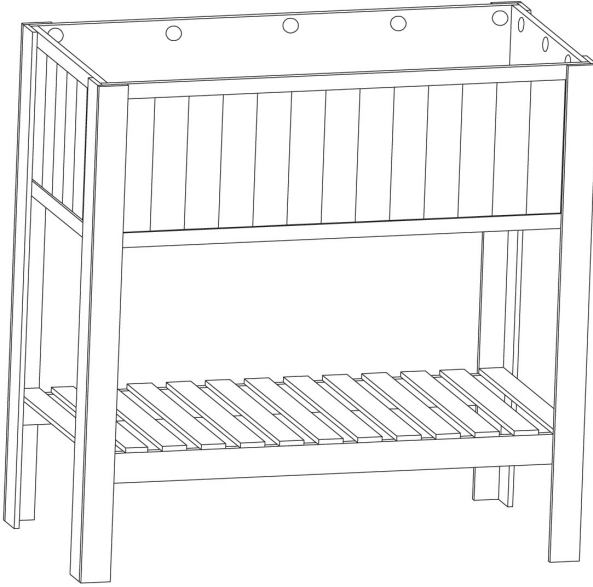

## CONTENU DE L'EMBALLAGE

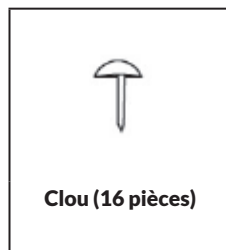
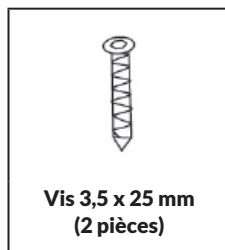
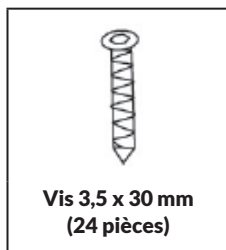
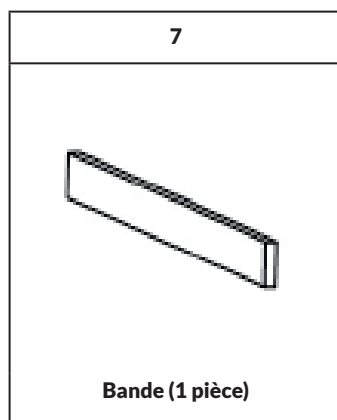
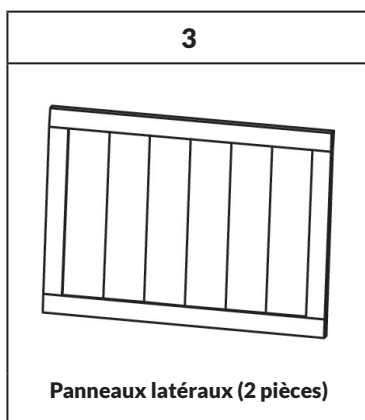
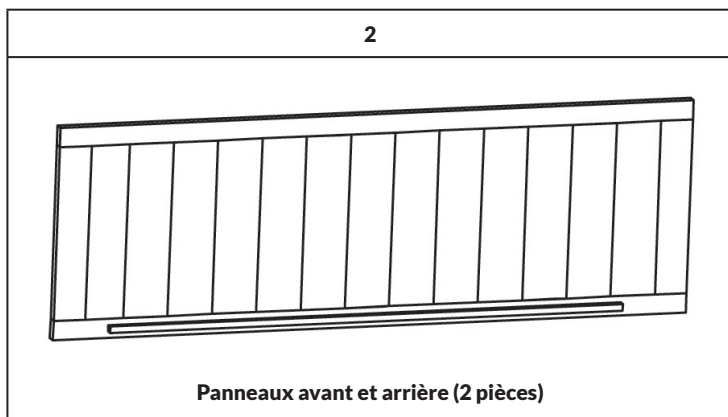
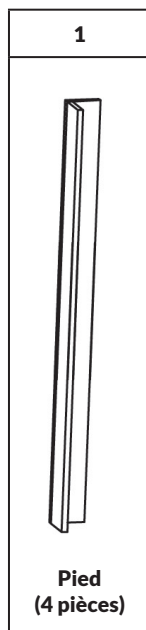

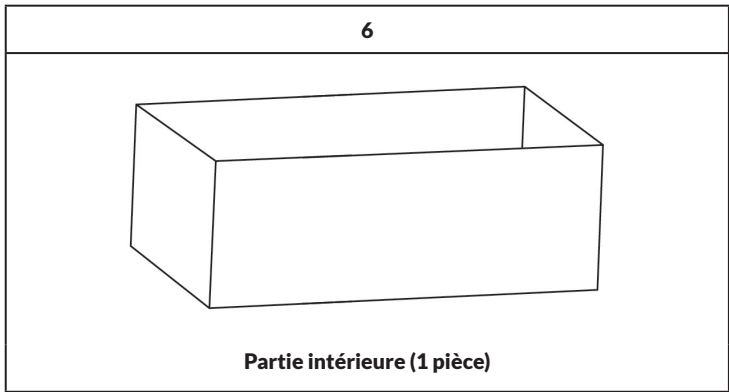
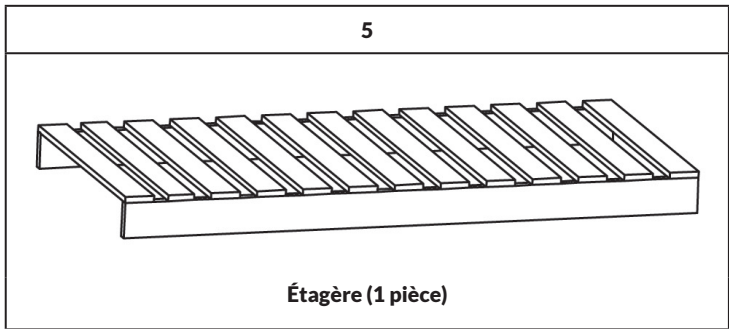
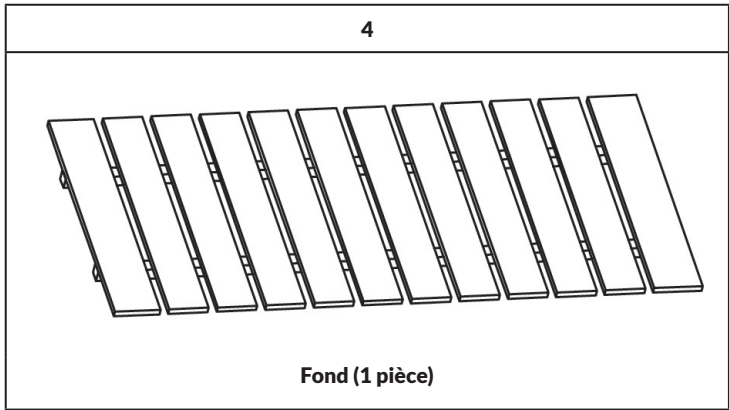

# MONTAGE

## Étape 1 :

Assemblez les panneaux avant et arrière (2) et les panneaux latéraux (3) à l'extrémité supérieure des 4 pieds (1) et vissez-les avec 16 vis (3,5 mm x 30 mm).

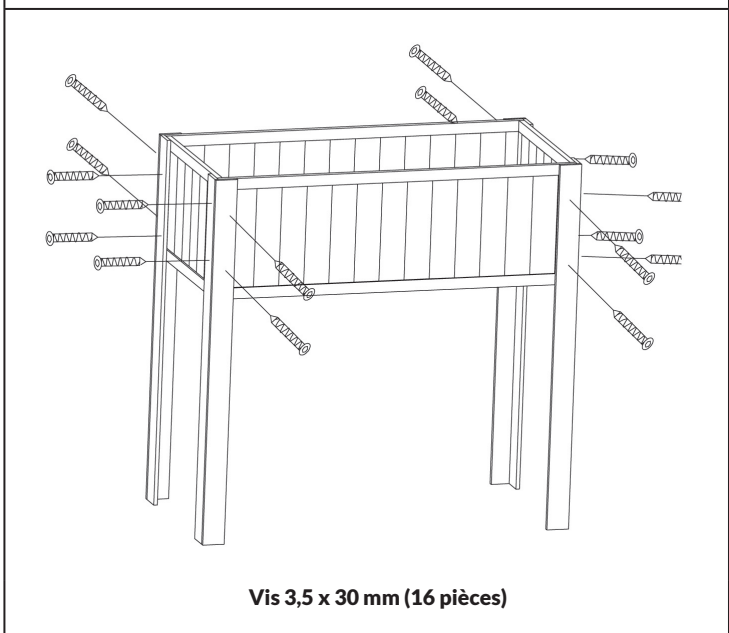

**Étape 2 :**

Montez l'étagère (5) dans la partie inférieure des quatre pieds (1) et vissez-la avec 8 vis (3,5 mm x 30 mm).

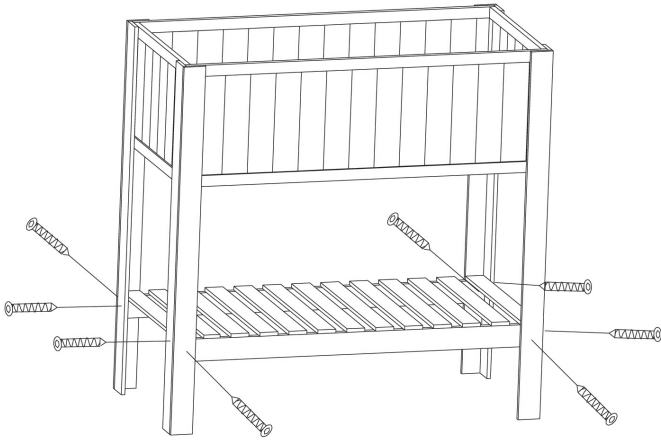

**Vis 3,5 x 30 mm (8 pièces)**

**Étape 3 :**

Placez maintenant le fond (4) par le haut dans le potager surélevé.

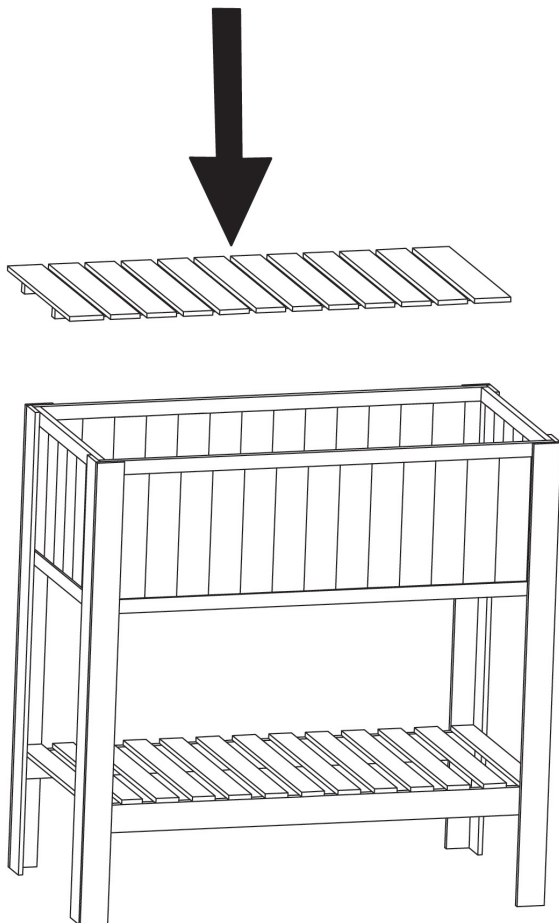



**Étape 4 :**

Fixez le fond (4) avec la bande (7) au potager surélevé par le bas avec 2 vis (3,5 mm x 25 mm).

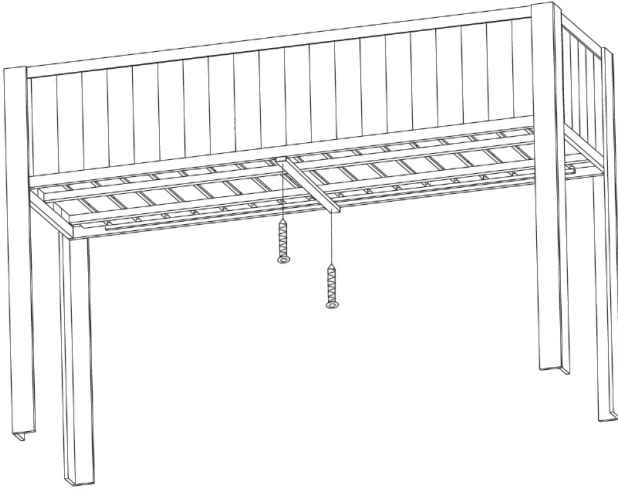

**Vis 3,5 x 25 mm (2 pièces)**

**Étape 5 :**

Fixez la partie intérieure (6) au potager surélevé avec 16 clous.

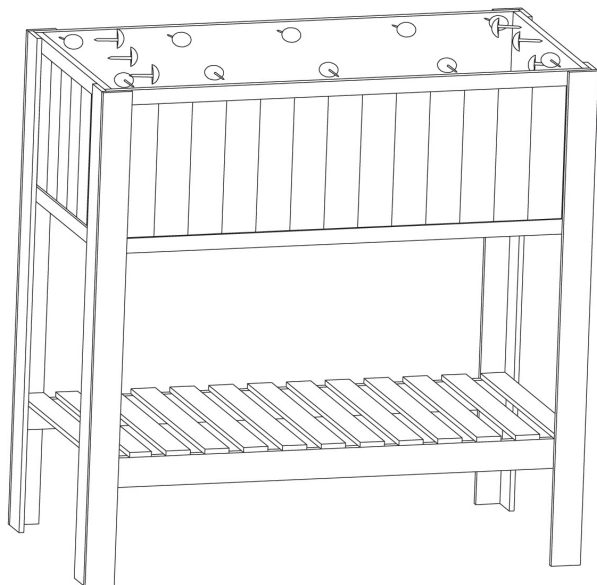

**Votre potager surélevé est maintenant entièrement assemblé et prêt à l'emploi.**

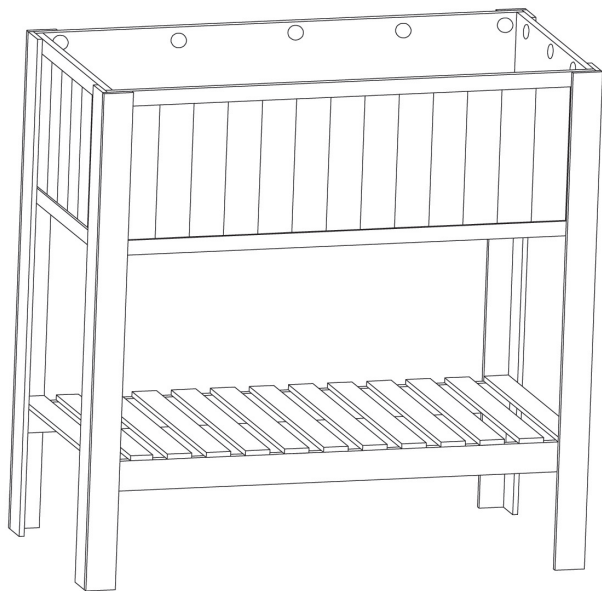

## VOLUME DI CONSEGNA

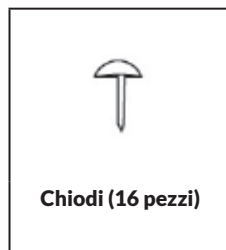
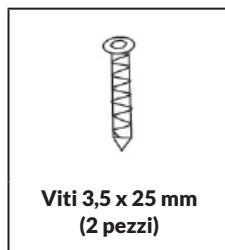
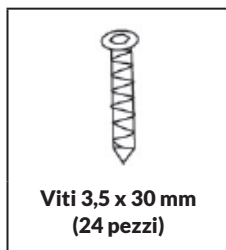
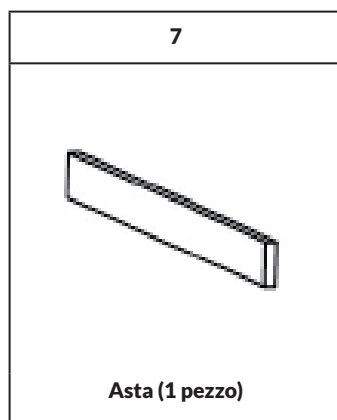
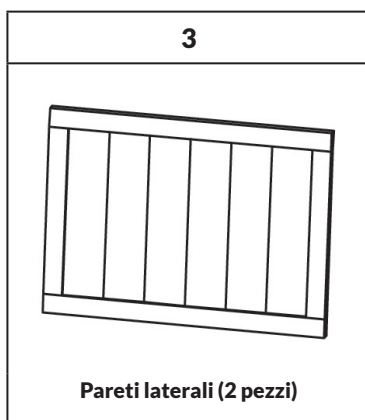
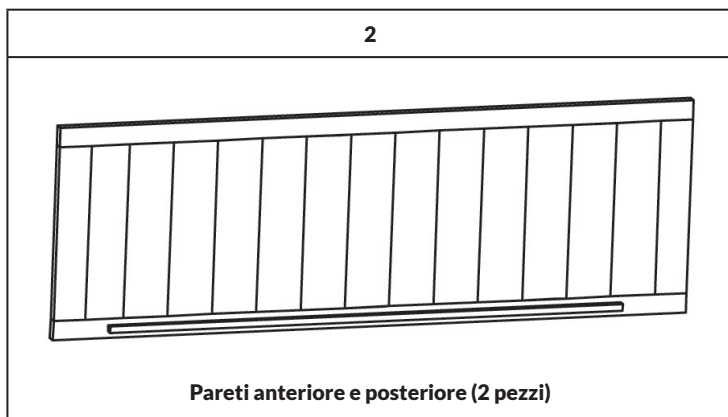
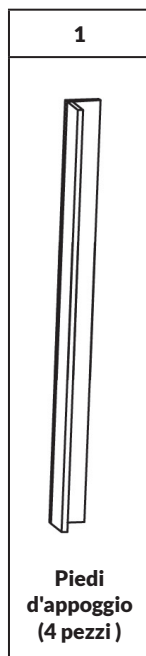

4

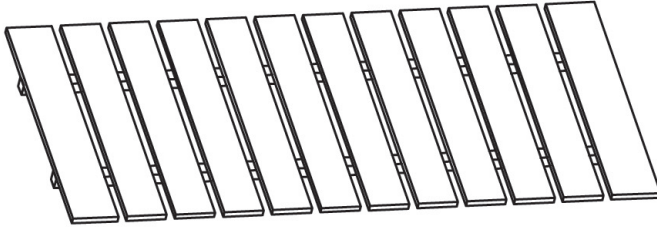
**Pannello di fondo (1 pezzo)**

5

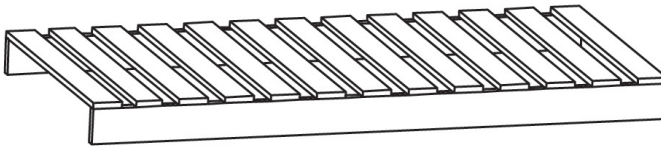
**Appoggio (1 pezzo)**

6

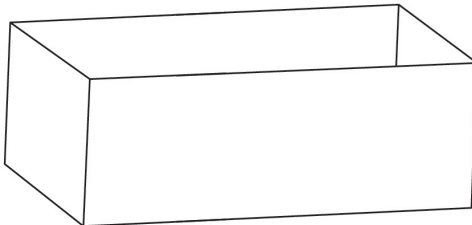
**Componente interno (1 pezzo)**

## MONTAGGIO

### 1° passaggio:

Montare le pareti anteriore, posteriore (2) e laterali (3) all'estremità superiore dei 4 piedi d'appoggio (1) e avvitarle saldamente con 16 viti (3,5 mm x 30 mm).

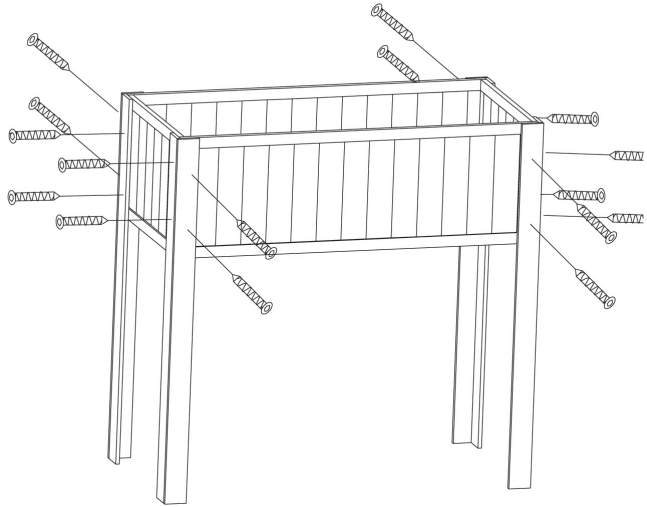

**Viti 3,5 x 30 mm (16 pezzi)**

**2° passaggio:**

Montare l'appoggio (5) sulla parte inferiore dei quattro piedi d'appoggio (1) e avvitarlo saldamente con 8 viti (3,5 mm x 30 mm).

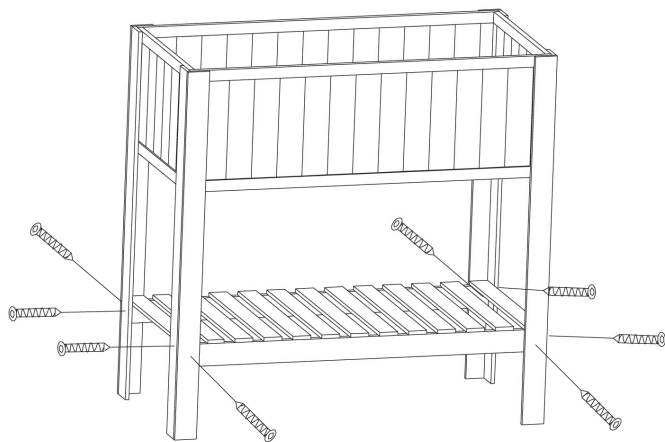

**Viti 3,5 x 30 mm (8 pezzi)**

**3° passaggio:**

Inserire dall'alto il pannello di fondo (4) nell'aiuola rialzata.

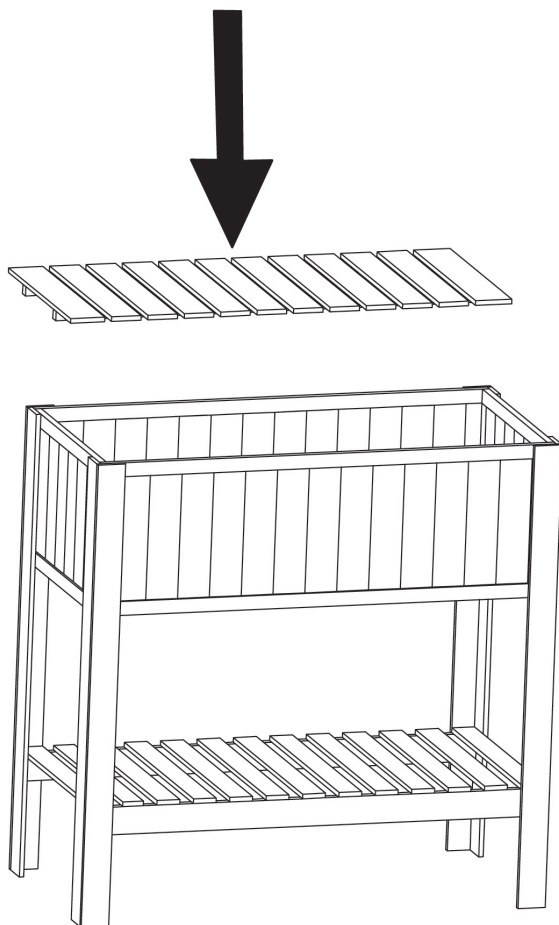



**4° passaggio:**

Fissare dal basso il pannello di fondo (4) all'aiuola rialzata con l'asta, utilizzando 2 viti (3,5 mm x 25 mm).

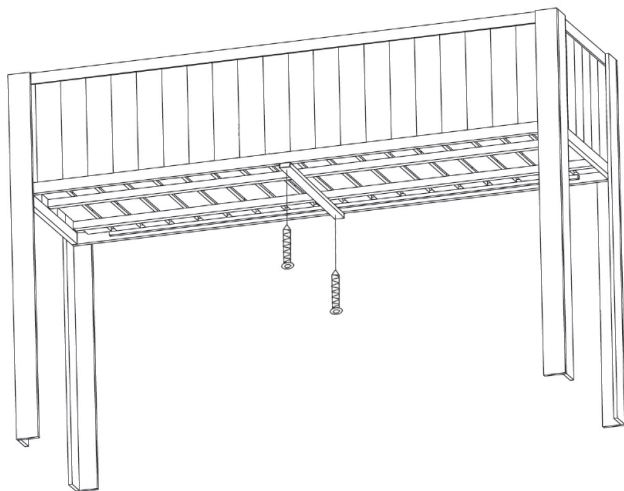

**Viti 3,5 x 25 mm (2 pezzi)**

**5° passaggio:**

Fissare il componente interno (6) all'aiuola rialzata con 16 chiodi.

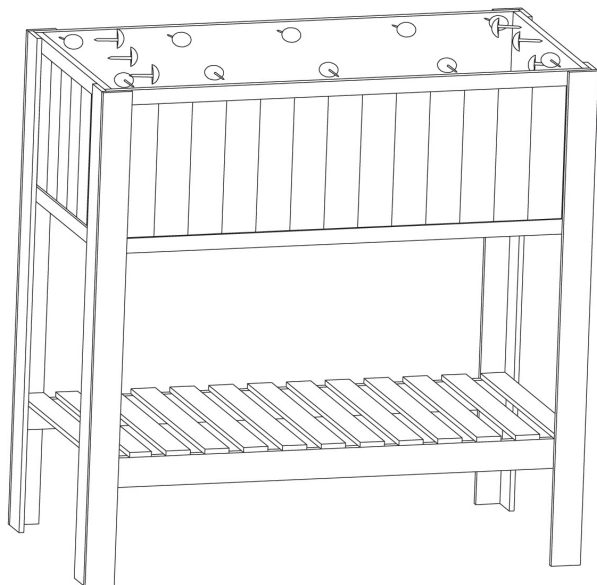

**L'aiuola rialzata è completamente montata e pronta all'uso.**

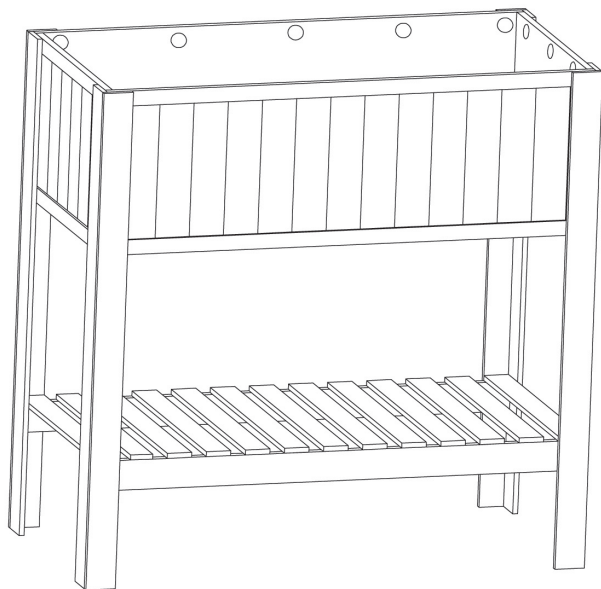

---

## **HERSTELLER**

---

**Manufacturer | Fabricante | Fabricant | Produttore**

Chal-Tec GmbH, Wallstraße 16, 10179 Berlin, Deutschland (Germany).

---

## **IMPORTEUR FÜR GROSSBRITANNIEN**

---

**Importer for Great Britain | Importador para Gran Bretaña | Importateur pour la Grande Bretagne | Importatore per la Gran Bretagna**

Berlin Brands Group UK Limited  
PO Box 42  
272 Kensington High Street  
London, W8 6ND  
United Kingdom







