



blumfeldt

Altiplano Terrado

Hochbeet

Raised Bed

Jardinería de suelo elevado

Potager surélevé

Aiuola rialzata

10033606



Sehr geehrter Kunde,

wir gratulieren Ihnen zum Erwerb Ihres Produkts. Lesen Sie die folgenden Hinweise sorgfältig durch und befolgen Sie diese, um möglichen Schäden vorzubeugen. Für Schäden, die durch Missachtung der Hinweise und unsachgemäßen Gebrauch entstehen, übernehmen wir keine Haftung. Scannen Sie den folgenden QR-Code, um Zugriff auf die aktuellste Bedienungsanleitung und weitere Informationen rund um das Produkt zu erhalten:

**Dear Customer,**

Congratulations on purchasing this product. Please read this manual carefully and take care of the following hints to avoid damages. Any failure caused by ignoring the items and cautions mentioned in the instruction manual is not covered by our warranty and any liability. Scan the QR code to get access to the latest user manual and other information about the product:



TECHNISCHE DATEN / TECHNICAL DATA

Artikelnummer	Item number	10033606
Maße (in cm)	Dimensions (in cm)	120 x 54 x 120

LIEFERUMFANG / PACKING CONTENT

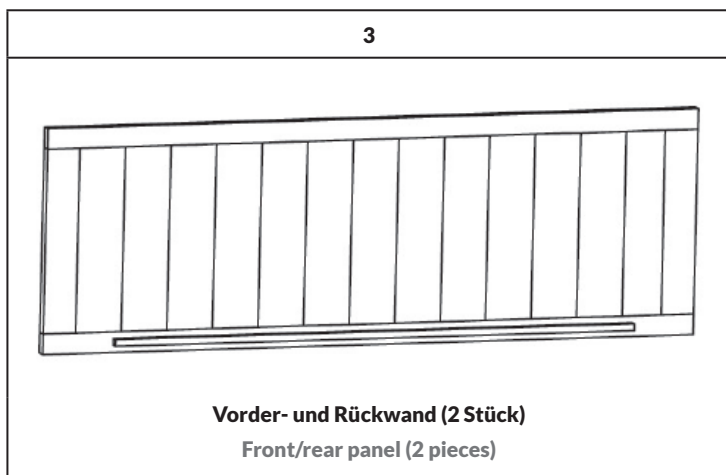
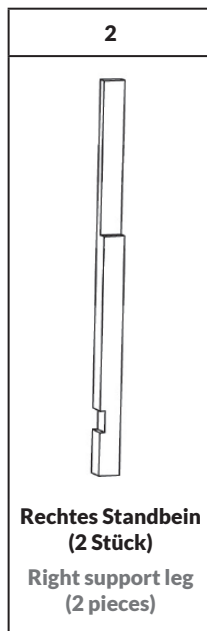
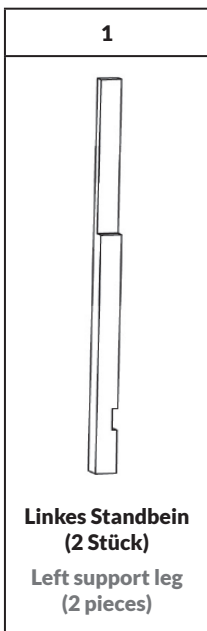

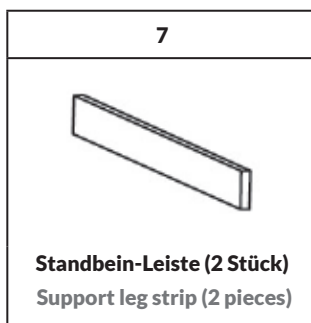
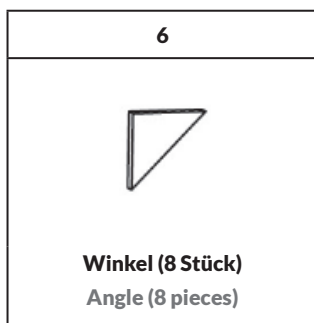
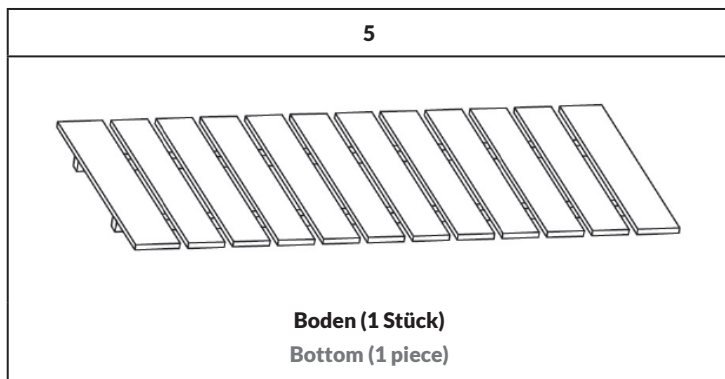
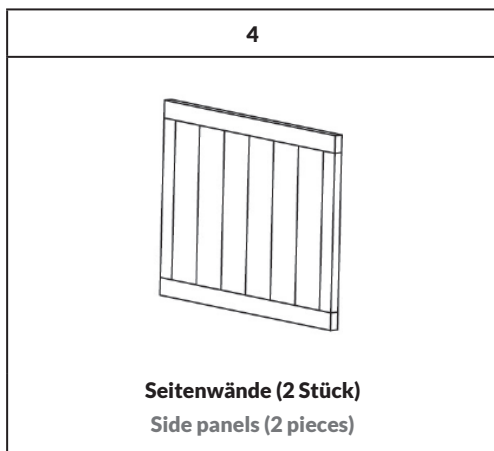

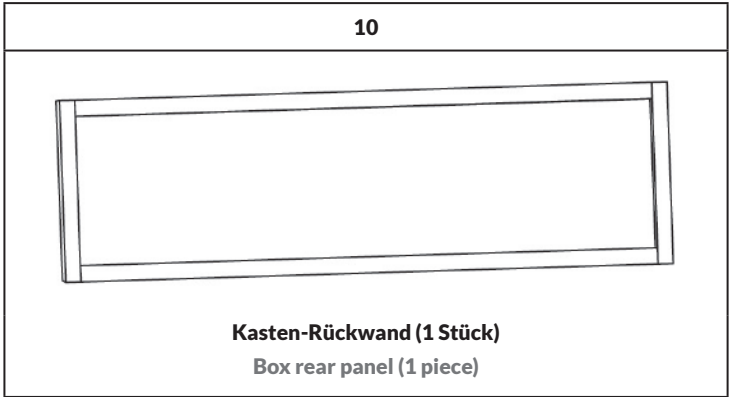
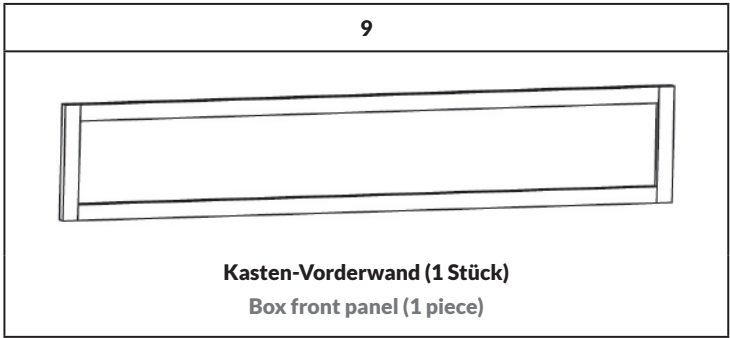
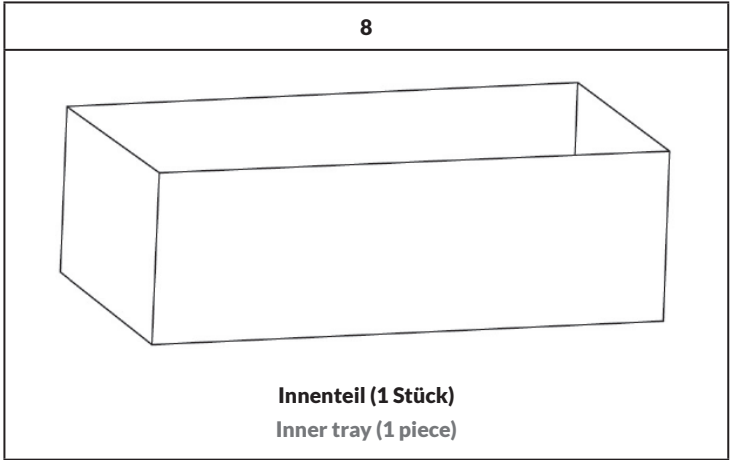

11

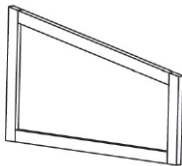

**Kasten-Seitenwand
(2 Stück)**

Box side panel
(2 pieces)

12

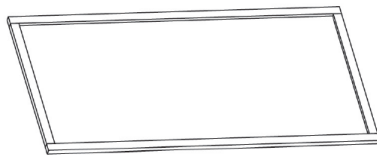

**Kasten-Deckel
(1 Stück)**

Box cover
(1 piece)

13



Scharnier (2 Stück)
Hinge (2 pieces)

14

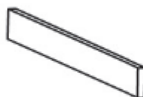

**Boden-Stützleiste
(1 Stück)**

Bottom support
strip (1 piece)



**Nagel
(16 Stück)**

Pin
(16 pieces)



**Schrauben
3 x 10 mm
(6 Stück)**

Screws
3 x 10 mm
(6 pieces)



**Schrauben
3 x 15 mm
(8 Stück)**

Screws
3.5 x 15 mm
(8 pieces)



**Schrauben
3,5 x 25 mm
(14 Stück)**

Screws
3.5 x 25 mm
(14 pieces)



**Schrauben
3,5 x 30 mm
(24 Stück)**

Screws
3.5 x 30 mm
(24 pieces)



**Schrauben
3,5 x 35 mm
(16 Stück)**

Screws
3.5 x 35 mm
(16 pieces)

MONTAGE / ASSEMBLY

Schritt 1:

Verschrauben Sie die Vorder- und Rückwand (3) und die Seitenwände (4) mit 8 Schrauben (3,5 mm x 35 mm).

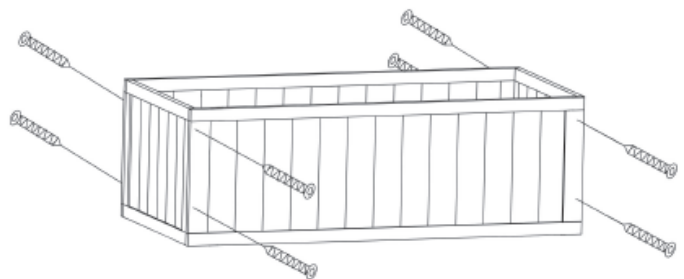

Schrauben 3,5 x 35 mm (8 Stück)
Screws 3.5 x 35 mm (8 pieces)

Step 1:

Screw the front and rear panels (3) and the side panels (4) together with 8 screws (3.5 mm x 35 mm).

Schritt 2:

Schrauben Sie die bereits montierten Vorder-, Rück- und Seitenwände (siehe Schritt 1) am oberen Ende der 4 Standbeine (1 und 2) mit 8 Schrauben (3,5 mm x 30 mm) fest.

Befestigen Sie am unteren Ende der linken (1) und rechten (2) Standbeine jeweils eine Leiste (7) in der Nut und schrauben Sie diese je Seite mit 4 Schrauben (3,5 mm x 25 mm) fest.

Schrauben 3,5 x 30 mm (8 Stück)

Screws 3.5 x 30 mm (8 pieces)

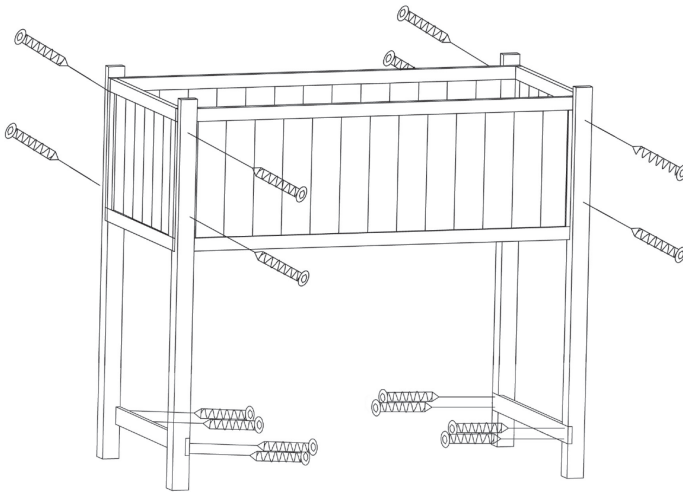
**Schrauben 3,5 x 25 mm (8 Stück)**

Screws 3.5 x 25 mm (8 pieces)

Step 2:

Fasten the already mounted front, rear and side panels (see step 1) to the upper end of the 4 support legs (1 and 2) with 8 screws (3.5 mm x 30 mm).

At the lower end of each of the left (1) and right (2) support legs, fasten a strip (7) in the groove and screw it tight with 4 screws (3.5 mm x 25 mm) on each side.

Schritt 3:

Befestigen Sie die Stützleiste (14) waagrecht von unten am Hochbett mit 2 Schrauben (3,5 mm x 25 mm).

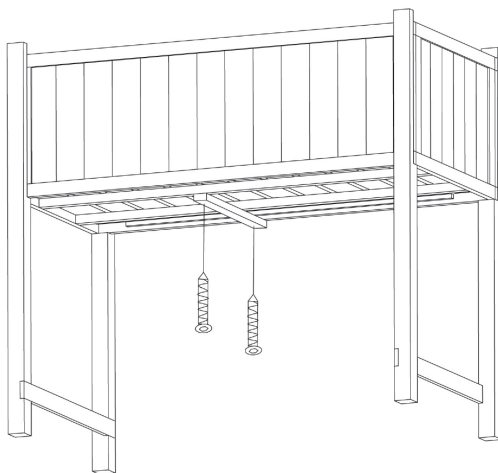

Schrauben 3,5 x 25 mm (2 Stück)

Screws 3,5 x 25 mm (2 pieces)

Step 3:

Fix the support strip (14) horizontally from below to the raised bed with 2 screws (3.5 mm x 25 mm).

Schritt 4:

Befestigen Sie die Winkel (6) mit 16 Schrauben (3,5 mm x 30 mm) am Hochbett und legen Sie den Boden (5) von oben in das Hochbett hinein.

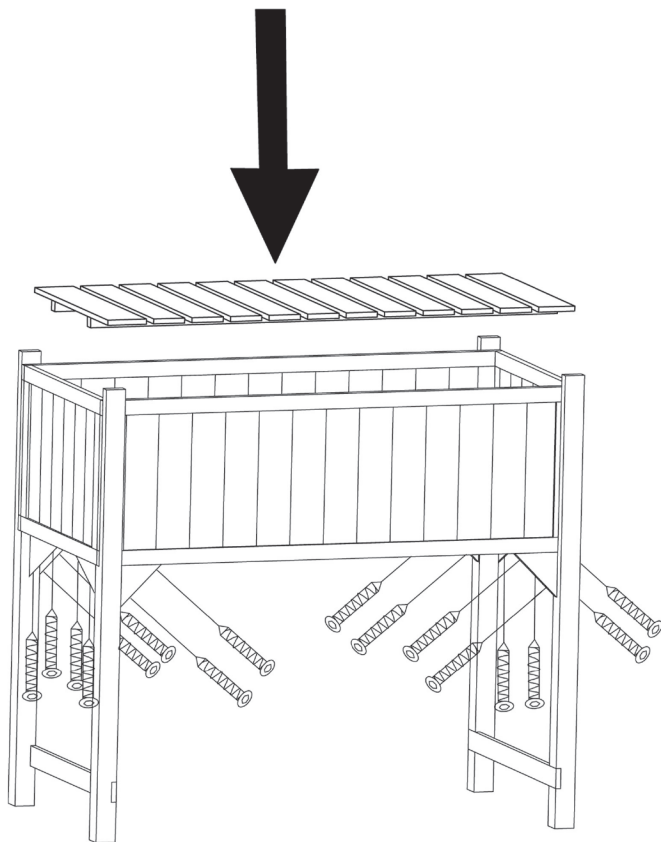
**Step 4:**

Fix the angles (6) to the raised bed with 16 screws (3.5 mm x 30 mm) and place the bottom (5) into the raised bed from above.

Schritt 5:

Befestigen Sie das Innenteil (8) mit 16 Nägeln im Hochbett.

Nägeln (16 Stück)

Pins (16 pieces)

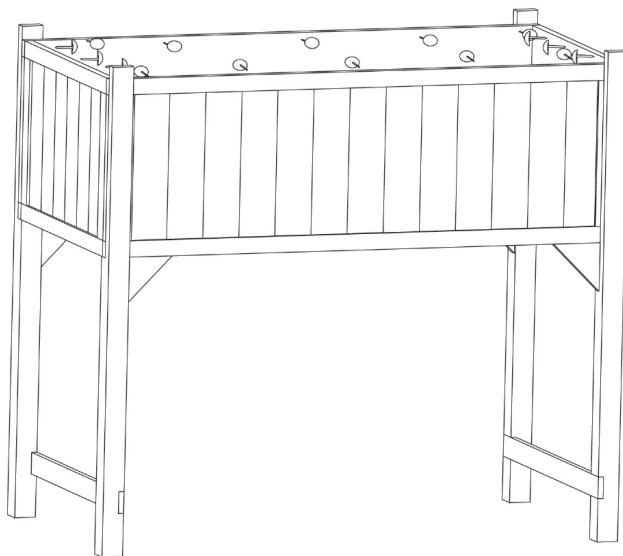

Step 5:

Fix the inner tray (8) with 16 pins in the raised bed.

Schritt 6:

Setzen Sie den Kasten aus Vorderwand (9), Rückwand (10) und 2 Seitenwänden (11) zusammen und schrauben Sie alle 4 Teile mit 8 Schrauben (5 mm x 35 mm) fest.

Schrauben 3,5 x 35 mm (8 Stück)

Screws 3.5 x 35 mm (8 pieces)

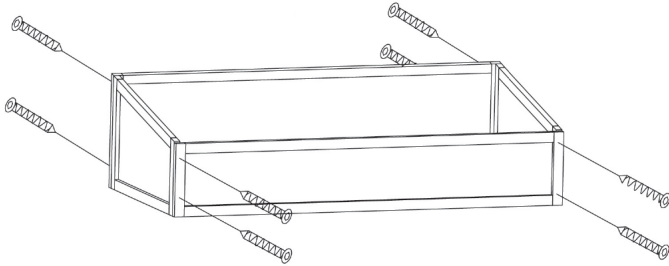
**Step 6:**

Assemble the box of front panel (9), rear panel (10) and 2 side panels (11) and tighten all 4 parts with 8 screws (5 mm x 35 mm).

Schritt 7:

Montieren Sie den Kasten mit 4 Schrauben (3,5 mm x 25 mm) im Hochbett.



Schrauben 3,5 x 25 mm (4 Stück)
Screws 3.5 x 25 mm (4 pieces)

Step 7:

Mount the box in the raised bed using 4 screws (3.5 mm x 25 mm).

Schritt 8:

Befestigen Sie den Kastendeckel (12) mit 6 Schrauben (3 mm x 10 mm) am Kasten.

Schrauben 3 x 10 mm (6 Stück)

Screws 3 x 10 mm (6 pieces)

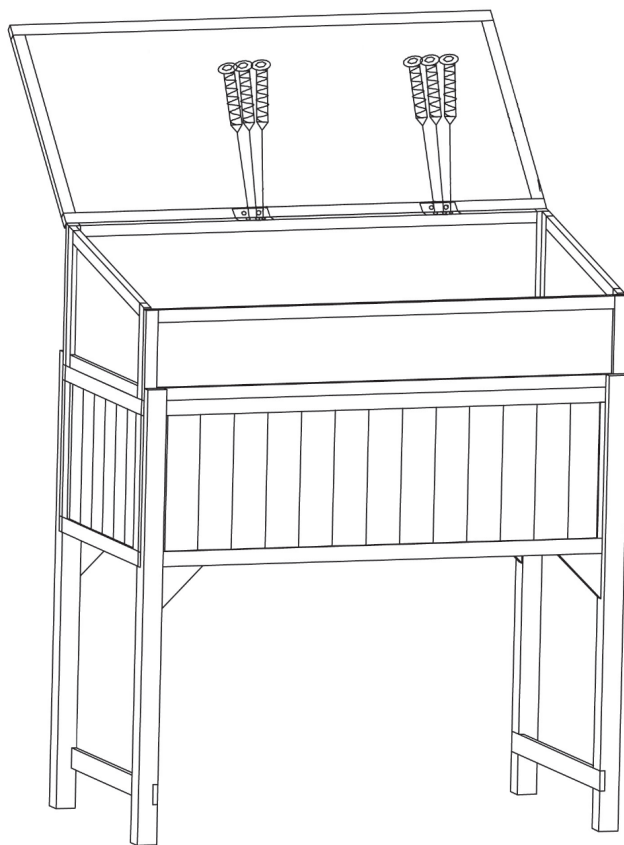
**Step 8:**

Fasten the box cover (12) to the box with 6 screws (3 mm x 10 mm).

Schritt 9:

Bringen Sie jeweils 1 Scharnier (13) an der linken und rechten Seite des Kastens an. Befestigen Sie das Scharnier jeweils mit 4 Schrauben (3 mm x 15 mm) an der Unterseite des Kastendeckels und an der Oberseite der Kasten-Seitenwand.

Schrauben 3 x 15 mm (8 Stück)

Screws 3 x 15 mm (8 pieces)

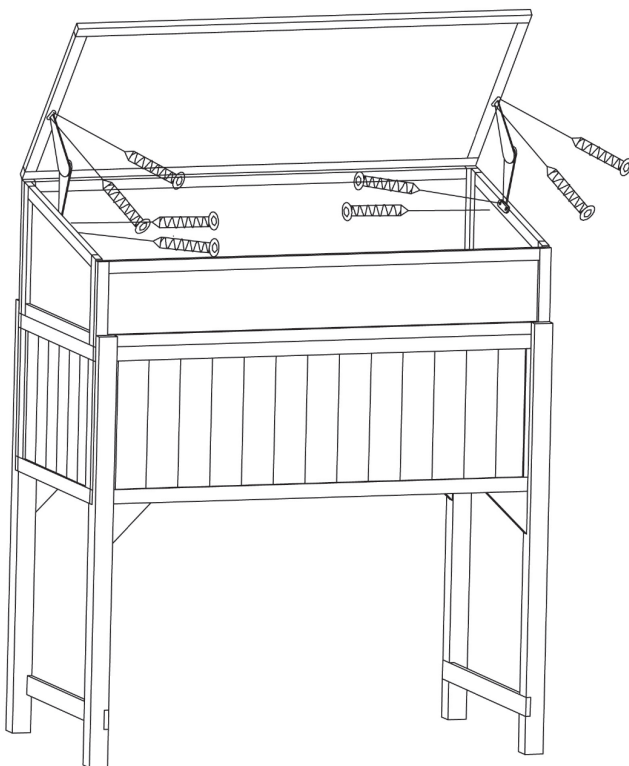

Step 9:

Attach 1 hinge (13) to each of the left and right sides of the box. Fasten the hinge with 4 screws (3 mm x 15 mm) at the bottom of the box cover and at the top of the box side wall.

Ihr Hochbett ist nun fertig montiert und einsatzbereit.
Your raised bed is now fully assembled and ready for use.

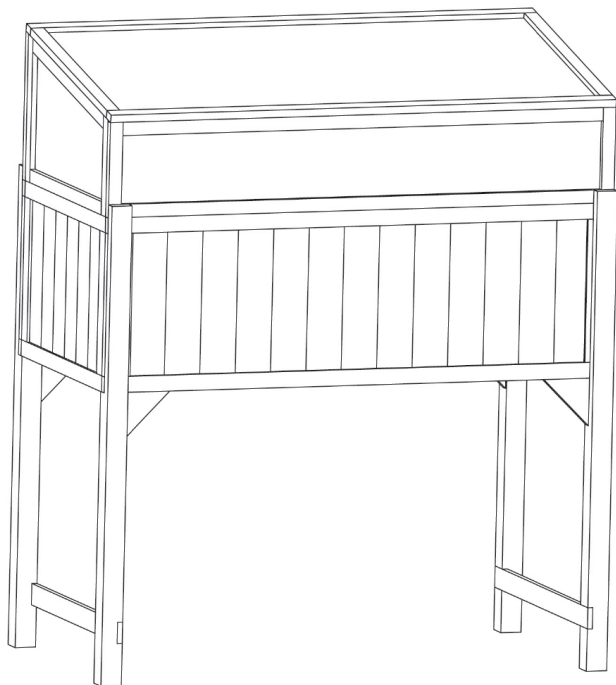

Estimado cliente:

Le felicitamos por la adquisición de este producto. Lea atentamente el siguiente manual y siga cuidadosamente las instrucciones de uso con el fin de evitar posibles daños. La empresa no se responsabiliza de los daños ocasionados por un uso indebido del producto o por haber desatendido las indicaciones de seguridad. Escanee el código QR para obtener acceso al manual de usuario más reciente y otra información sobre el producto:

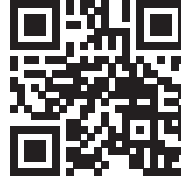
**Chère cliente, cher client,**

Toutes nos félicitations pour l'acquisition de ce nouvel produit. Veuillez lire attentivement et respecter les instructions de ce mode d'emploi afin d'éviter d'éventuels dommages. Nous ne saurions être tenus pour responsables des dommages dus au non-respect des consignes et à la mauvaise utilisation de l'appareil. Scannez le QR-Code pour obtenir la dernière version du mode d'emploi et des informations supplémentaires concernant le produit :



DATOS TÉCNICOS / FICHE TECHNIQUE

Número de artículo	Numéro d'article	10033606
Dimensiones (en cm)	Dimensions (en cm)	120 x 54 x 120

**ALCANCE DE SUMINISTRO /
CONTENU DE L'EMBALLAGE**

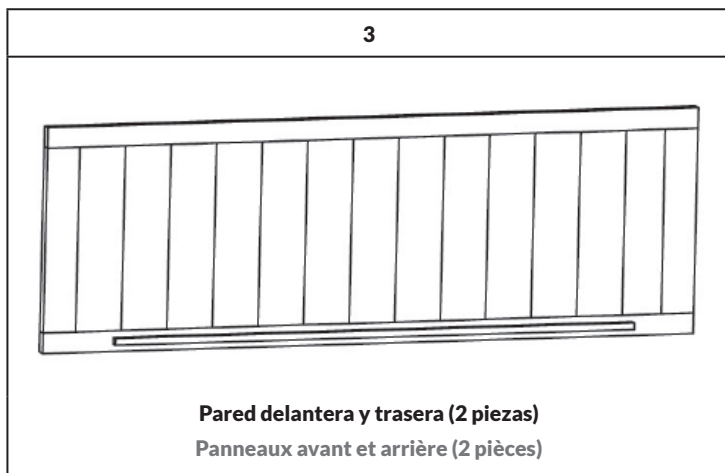
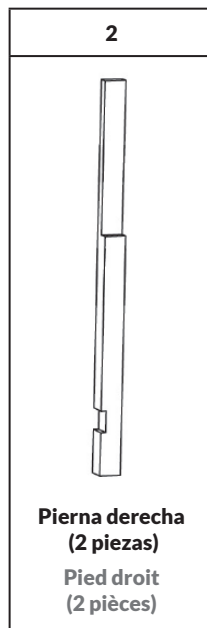
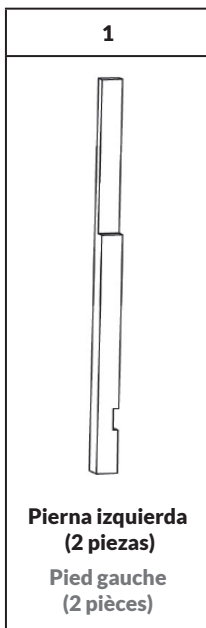

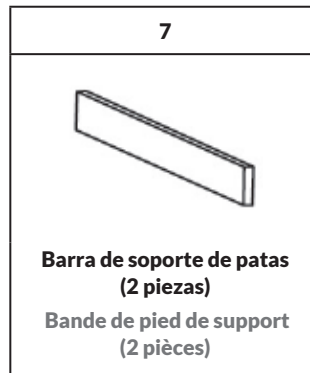
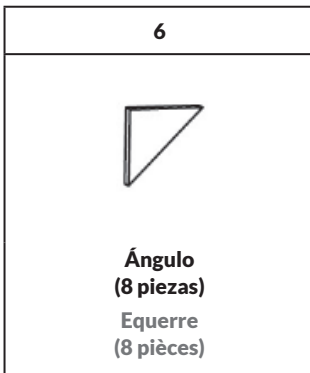
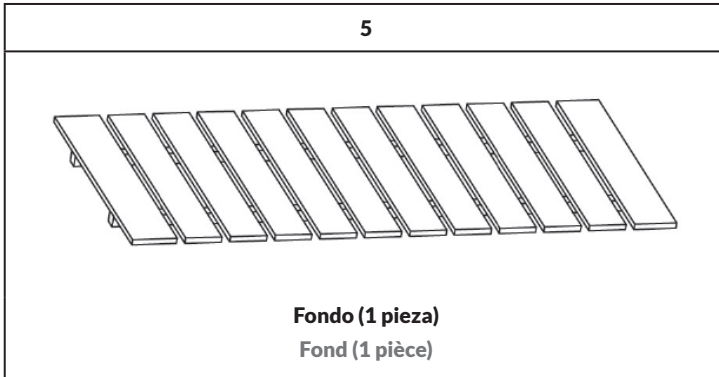
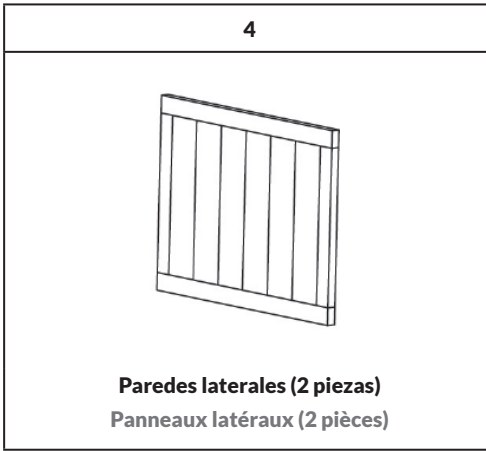

8

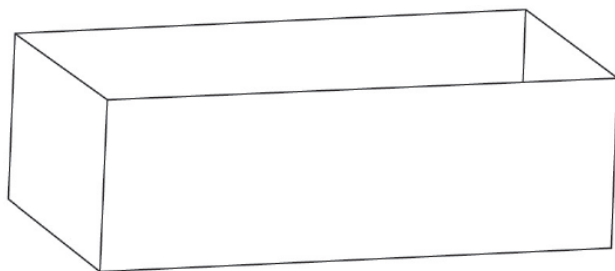

Parte interior (1 pieza)
Élément intérieur (1 pièce)

9

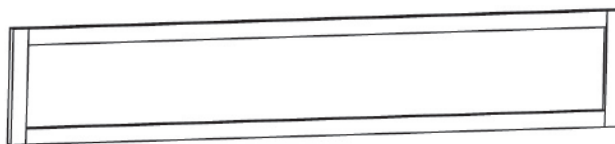

Pared frontal de la caja (1 pieza)
Panneau avant de la caisse (1 pièce)

10

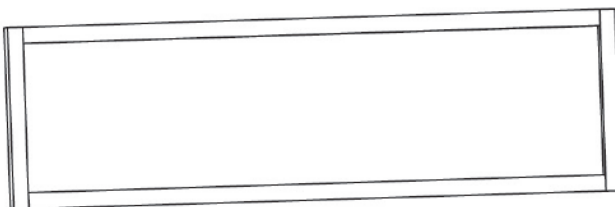

Pared trasera de la caja (1 pieza)
Panneau arrière de la caisse (1 pièce)

11

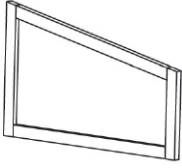

**Pared lateral de la caja
(2 piezas)**

**Panneaux latérales de la
caisse (2 pièces)**

12

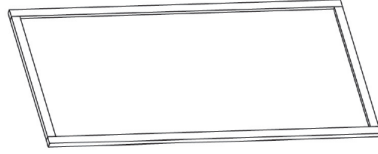

**Tapa de la caja
(1 pieza)**

**Couvercle de la caisse
(1 pièce)**

13



**Bisagra (2 piezas)
Charnière (2 pièces)**

14



**Banda de soporte
de suelo (1 pieza)
Planche support du
fond (1 pièce)**



**Clavo
(16 piezas)
Clou
(16 pièces)**



**Tornillos
3 x 10 mm
(6 piezas)**

**Vis
3 x 10 mm
(6 pièces)**



**Tornillos
3 x 15 mm
(8 piezas)**

**Vis
3 x 15 mm
(8 pièces)**



**Tornillos
3,5 x 25 mm
(14 piezas)**

**Vis
3,5 x 25 mm
(14 pièces)**



**Tornillos
3,5 x 30 mm
(24 piezas)**

**Vis
3,5 x 30 mm
(24 pièces)**



**Tornillos
3,5 x 35 mm
(16 piezas)**

**Vis
3,5 x 35 mm
(16 pièces)**

MONTAJE / MONTAGE

Paso 1:

Atornille los paneles delantero y trasero (3) y los paneles laterales (4) con 8 tornillos (3,5 mm x 35 mm).

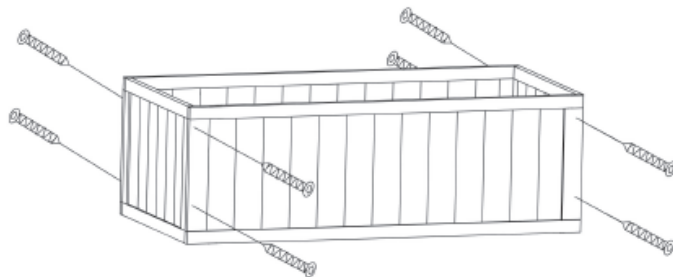

Tornillos 3,5 x 35 mm (8 piezas)

Vis 3,5 x 35 mm (8 pièces)

Étape 1 :

Vissez les panneaux avant et arrière (3) et les panneaux latéraux (4) avec 8 vis (3,5 mm x 35 mm).

Paso 2:

Atornille los paneles frontal, trasero y laterales ya montados (véase el paso 1) al extremo superior de las 4 patas de apoyo (1 y 2) con 8 tornillos (3,5 mm x 30 mm).

En el extremo inferior de cada una de las patas de apoyo izquierda (1) y derecha (2), fije una banda (7) en la ranura y atornillela en su sitio con 4 tornillos (3,5 mm x 25 mm) a cada lado.

Tornillos 3,5 x 30 mm (8 piezas)

Vis 3,5 x 35 mm (8 pièces)

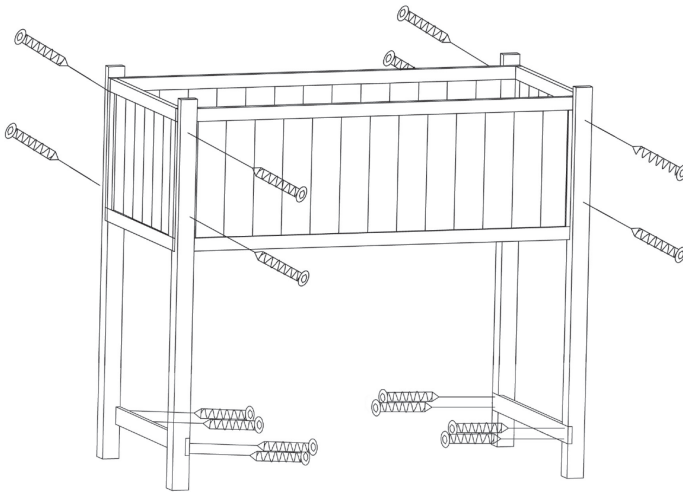
**Tornillos 3,5 x 25 mm (8 piezas)**

Vis 3,5 x 35 mm (8 pièces)

Étape 2 :

Vissez les panneaux avant, arrière et latéraux déjà montés (voir étape 1) en haut des 4 pieds (1 et 2) à l'aide de 8 vis (3,5 mm x 30 mm).

Au bas des pieds gauche (1) et droit (2), fixez un rebord (7) dans la rainure et serrez chaque côté avec 4 vis (3,5 mm x 25 mm).

Paso 3:

Fije la tira de soporte (14) horizontalmente desde abajo a la jardinería de suelo elevado con 2 tornillos (3,5 mm x 25 mm).

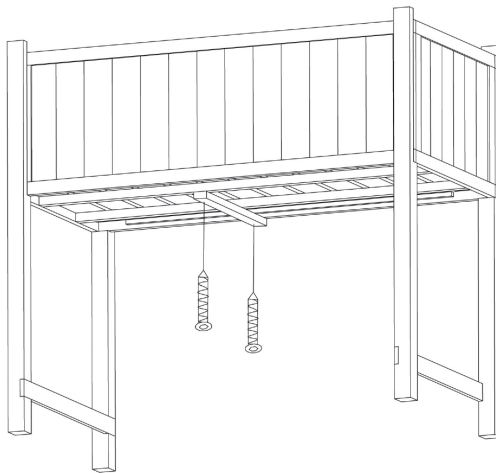

Tornillos 3,5 x 25 mm (2 piezas)

Vis 3,5 x 25 mm (2 pièces)

Étape 3:

Fixez la bande de support (14) horizontalement sous le potager surélevé à l'aide de 2 vis (3,5 mm x 25 mm).

Paso 4:

Fije los ángulos (6) a la jardinería de suelo elevado con 16 tornillos (3,5 mm x 30 mm) y coloque el suelo (5) en la jardinería de suelo elevado desde arriba.

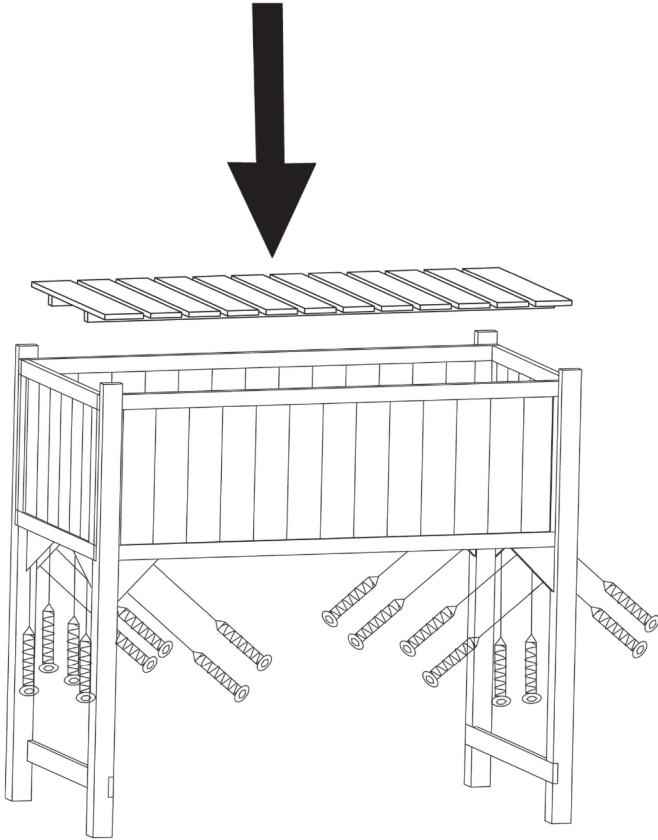
**Etape 4 :**

Fixez les équerres (6) à l'aide de 16 vis (3,5 mm x 30 mm) sur le potager surélevé et placez le fond (5) dans le potager surélevé par le haut.

Paso 5:

Sujete la parte interior (8) con 16 clavos en la jardinería de suelo elevado.

Clavos (16 piezas)

Clou (16 pièces)

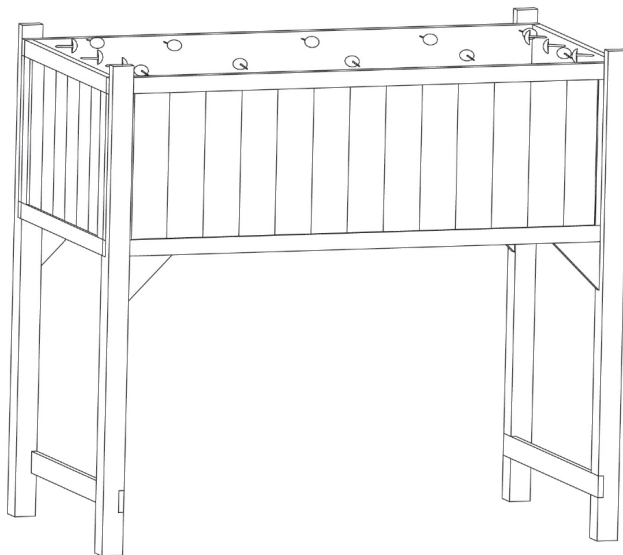
**Étape 5 :**

Fixer la partie intérieure (8) avec 16 clous dans le potager surélevé.

Paso 6:

Monte la caja del panel frontal (9), panel trasero (10) y 2 paneles laterales (11) y apriete las 4 partes con 8 tornillos (5 mm x 35 mm).

Tornillos 3,5 x 35 mm (8 piezas)

Vis 3,5 x 35 mm (8 pièces)

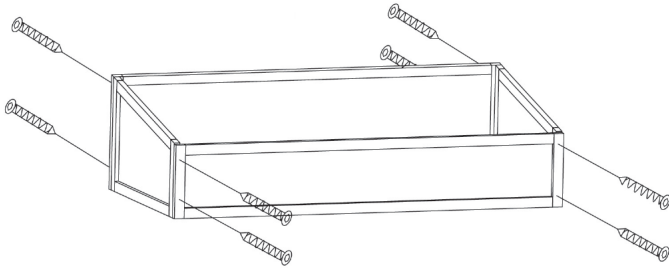
**Etape 6 :**

Assemblez la caisse avec les parois avant (9), arrière (10) et latérales (11) et serrez les 4 pièces à l'aide de 8 vis (5 mm x 35 mm).

Paso 7:

Atornille la caja en la jardinería de suelo elevado con 4 tornillos (3,5 mm x 25 mm).



Tornillos 3,5 x 25 mm (4 piezas)

Vis 3,5 x 25 mm (4 pièces)

Etape 7 :

Montez la caisse avec 4 vis (3,5 mm x 25 mm) dans le potager surélevé.

Paso 8:

Sujete la tapa de la caja (12) a la caja con 6 tornillos (3 mm x 10 mm).

Tornillos 3 x 10 mm (6 piezas)

Vis 3 x 10 mm (6 pièces)

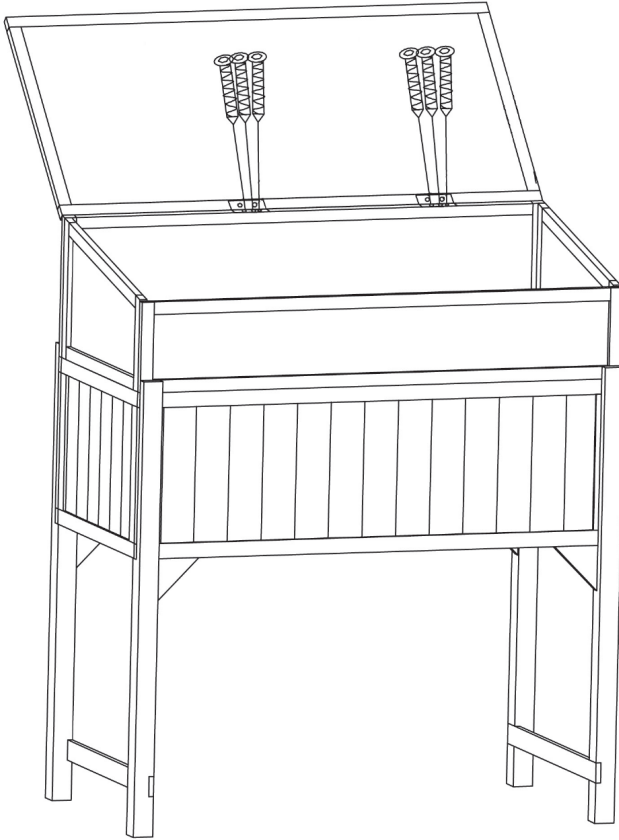
**Etape 8 :**

Fixez le couvercle de la caisse (12) sur la caisse avec 6 vis (3 mm x 10 mm).

Paso 9:

Coloque 1 bisagra (13) en cada uno de los lados izquierdo y derecho de la caja. Fije la bisagra con 4 tornillos (3 mm x 15 mm) en la parte inferior de la tapa de la caja y en la parte superior de la pared lateral de la caja.

Tornillos 3 x 15 mm (8 piezas)

Vis 3 x 15 mm (8 pièces)

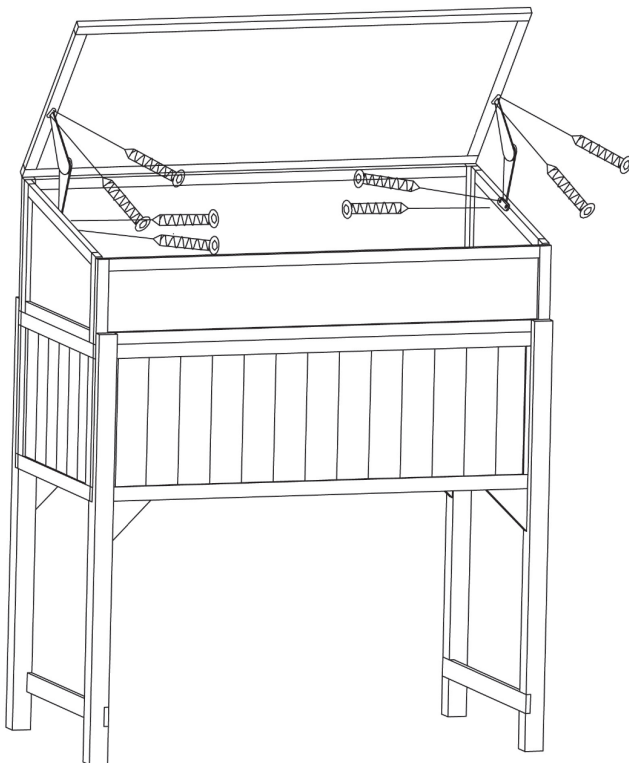
**Etape 9 :**

Fixez 1 charnière (13) sur les côtés gauche et droit de la caisse. Fixez la charnière sur la face inférieure du couvercle de la caisse et sur le haut du panneau latéral de la caisse à l'aide de 4 vis (3 mm x 15 mm).

**Su jardinería de suelo elevado ya está completamente montada
y lista para su uso.**

**Vous avez terminé l'assemblage de votre potager surélevé,
il est maintenant prêt à l'emploi.**

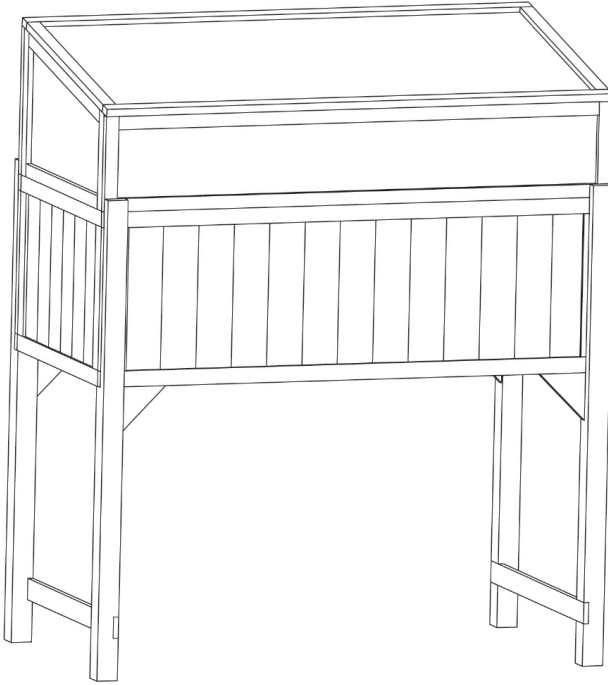

Gentile cliente,

La ringraziamo per aver acquistato il prodotto. La preghiamo di leggere attentamente le seguenti istruzioni per l'uso e di seguirle per evitare possibili danni tecnici. Non ci assumiamo alcuna responsabilità per danni scaturiti da una mancata osservazione delle avvertenze di sicurezza e da un uso improprio del dispositivo. Scansionare il codice QR seguente, per accedere al manuale d'uso più attuale e per ricevere informazioni sul prodotto.



DATI TECNICI

Numero articolo	10033606
Dimensioni (in cm)	120 x 54 x 120

VOLUME DI CONSEGNA

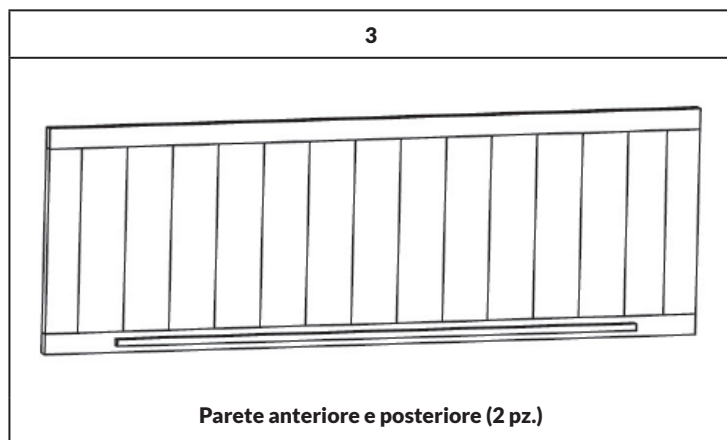
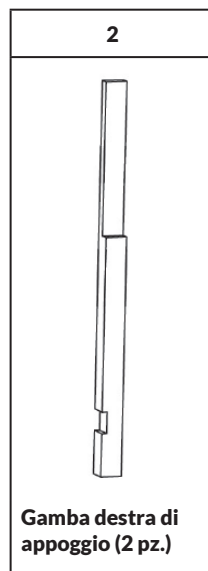
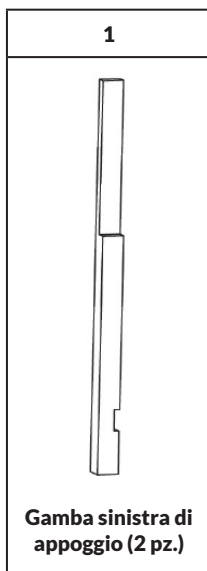

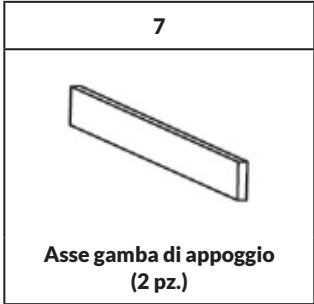
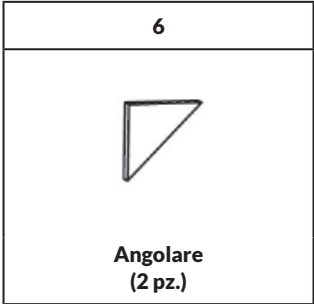
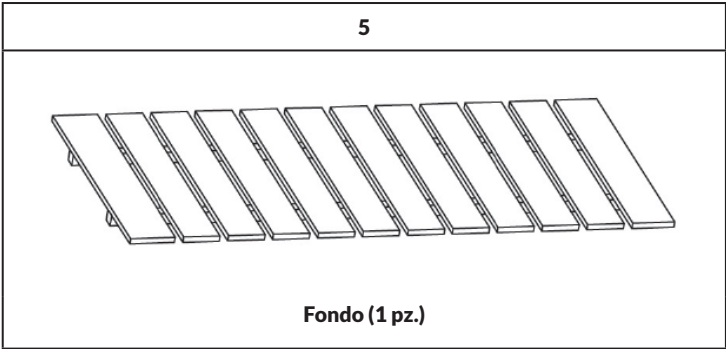
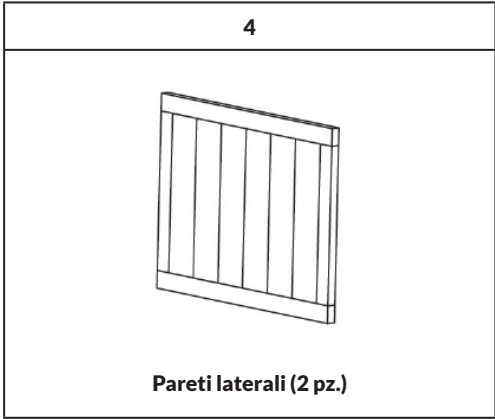

8

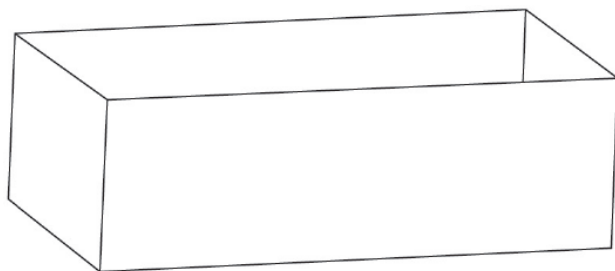
**Componente interno (1 pz.)**

9

**Parete anteriore cassa (1 pz.)**

10

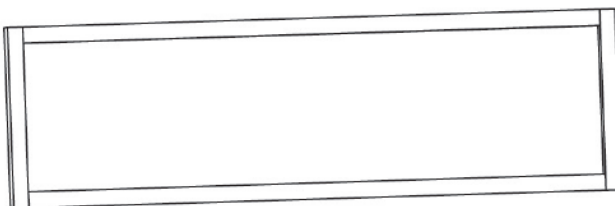
**Parete posteriore cassa (1 pz.)**

11

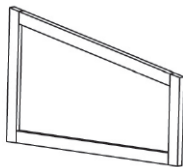

Parete laterale cassa
(2 pz.)

12

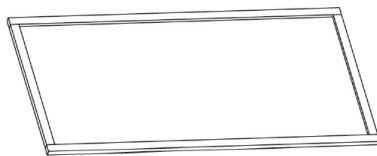

Coperchio cassa
(1 pz.)

13



Cerniera
(2 pz.)

14



**Asse di supporto
fondo (1 pz.)**



Chiodo
(16 pz.)



Vite
3 x 10 mm
(6 pz.)



Vite
3 x 15 mm
(8 pz.)



Vite
3,5 x 25 mm
(14 pz.)



Vite
3,5 x 30 mm
(24 pz.)



Vite
3,5 x 35 mm
(16 pz.)

MONTAGGIO

1° passaggio:

Avvitare con 8 viti (3,5 mm x 35 mm) le pareti anteriore e posteriore (3) e le pareti laterali (4).

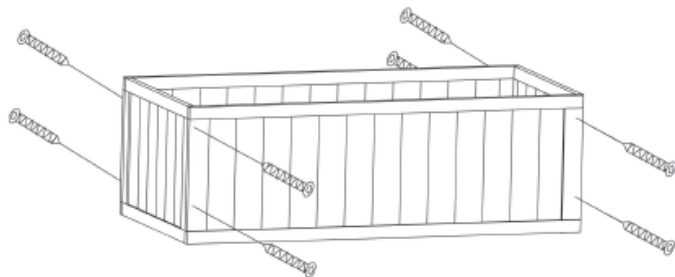

Vite 3,5 x 35 mm (8 pz.)

2° passaggio:

Avvitare le pareti anteriore, posteriore e le pareti laterali già assemblate (v. 1° passaggio) all'estremità superiore delle gambe di appoggio (1 e 2) con 8 viti (3,5 mm x 30 mm).

Fissare un'asse alla cavità sull'estremità inferiore delle gambe di appoggio sinistra (1) e destra (2) e avvitare su ogni lato con 4 viti (3,5 mm x 25 mm).

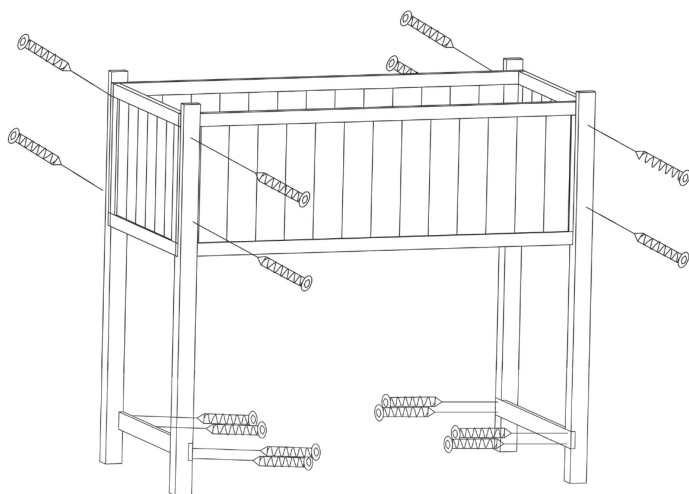
Vite 3,5 x 30 mm (8 pz.)**Vite 3,5 x 25 mm (8 pz.)**

3° passaggio:

Fissare l'asse di supporto (14) all'aiuola rialzata con 2 viti (3,5 mm x 25 mm) orizzontalmente dal basso.

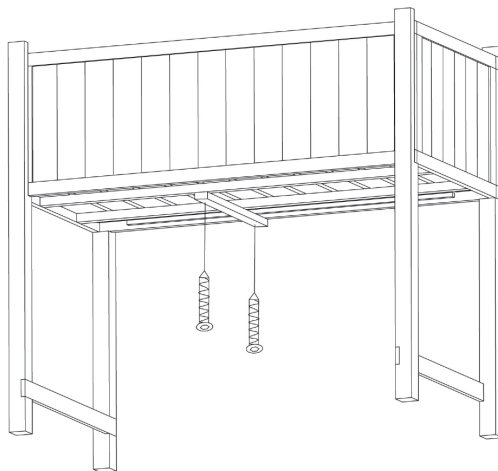

Vite 3,5 x 25 mm (2 pz.)

4° passaggio:

Fissare gli angolari (6) all'aiuola rialzata con 16 viti (3,5 mm x 30 mm) e inserire dall'alto il fondo (5) nell'aiuola.

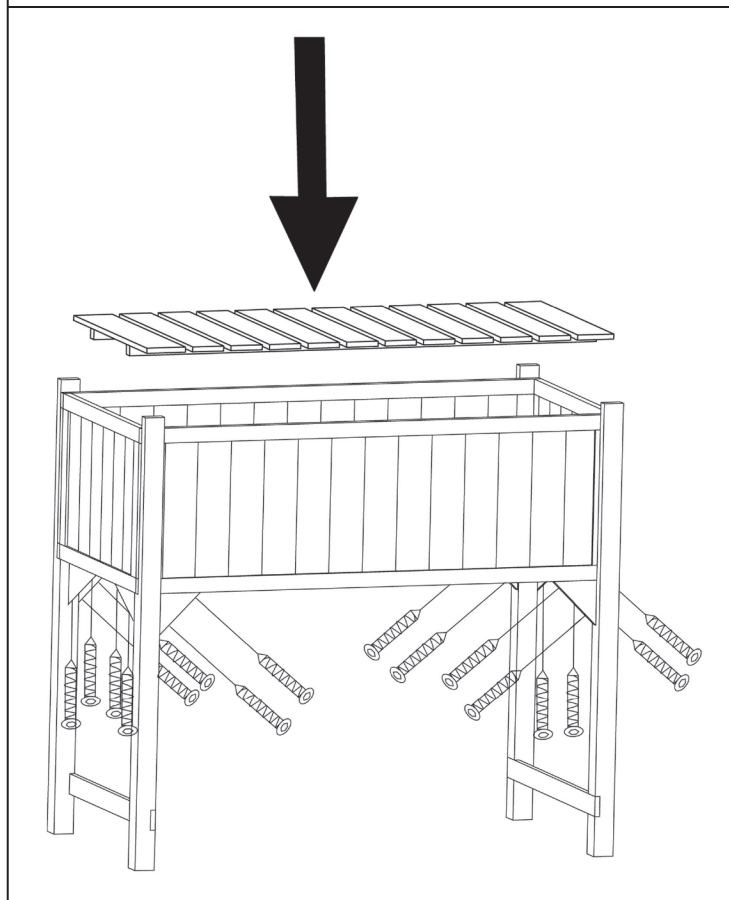

5° passaggio:

Fissare il componente interno (8) nell'aiuola con 16 chiodi.

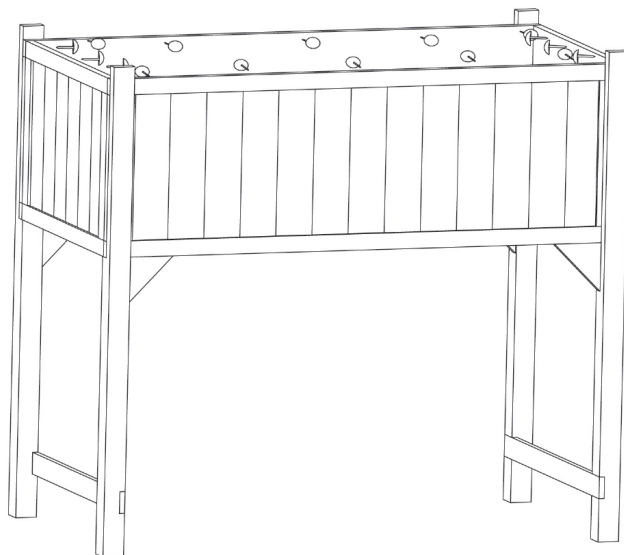
Chiodi (16 pz.)

6° passaggio:

Assemblare la cassa composta da parete anteriore (9), posteriore (10) e 2 pareti laterali (11) e avvitare le 4 parti con 8 viti (5 mm x 35 mm).

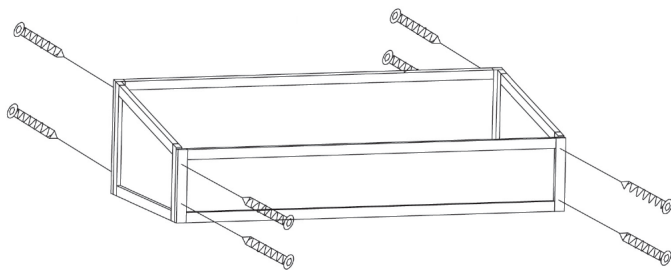
Vite 3,5 x 35 mm (8 pz.)

7° passaggio:

Montare la cassa nell'aiuola con 4 viti (3,5 mm x 25 mm).



Vite 3,5 x 25 mm (4 pz.)

8° passaggio:

Fissare il coperchio (12) alla cassa con 6 viti (3 mm x 10 mm).

Vite 3 x 10 mm (6 pz.)

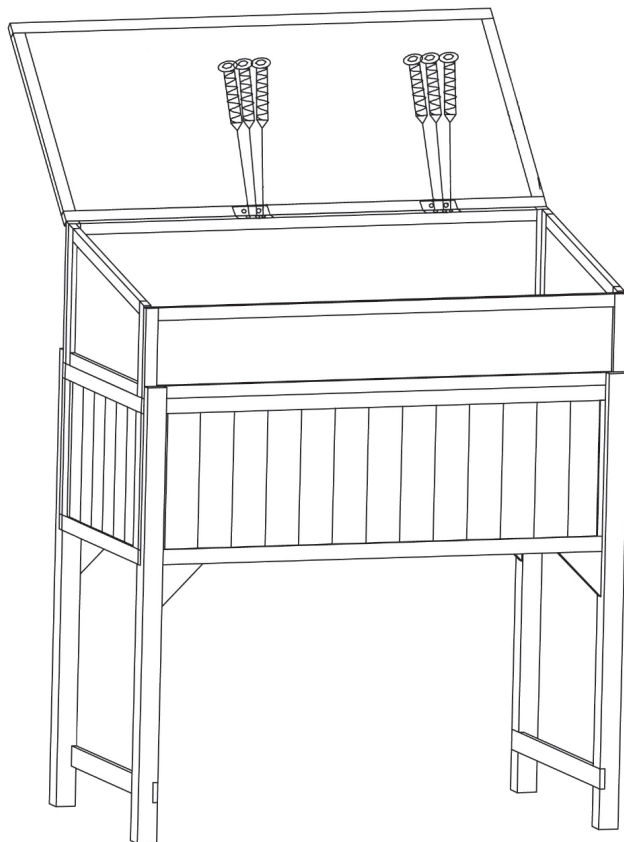

9° passaggio:

Montare una cerniera (13) sul lato sinistro e sul lato destro della cassa. Fissare ogni cerniera con 4 viti (3 mm x 15 mm) al lato inferiore del coperchio della cassa e al lato superiore della parete laterale della cassa.

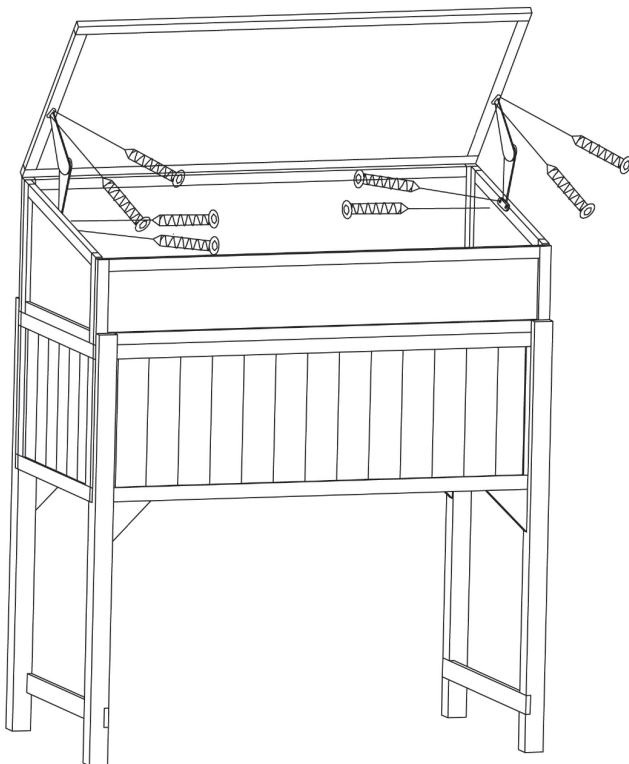
Vite 3 x 15 mm (8 pz.)

L'aiuola rialzata è ora completamente montata ed è pronta all'uso.

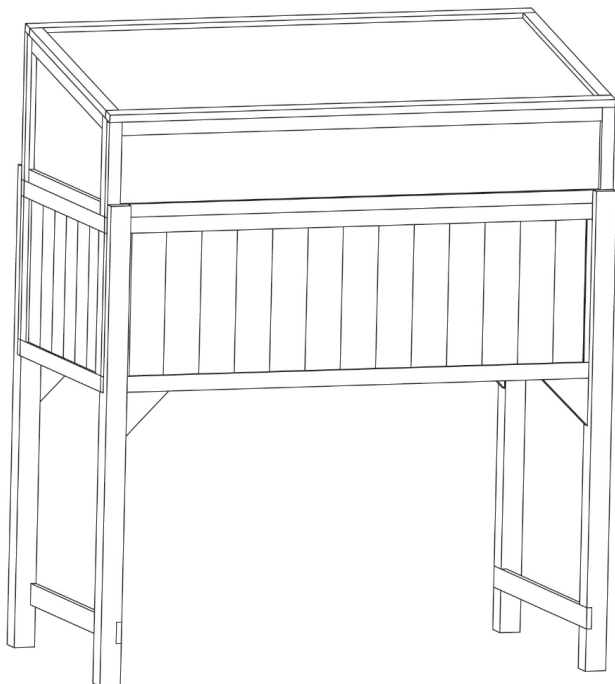

HERSTELLER

Manufacturer | Fabricante | Fabricant | Produttore

Chal-Tec GmbH, Wallstraße 16, 10179 Berlin, Deutschland (Germany).

IMPORTEUR FÜR GROSSBRITANNIEN

Importer for Great Britain | Importador para Gran Bretaña | Importateur pour la Grande Bretagne | Importatore per la Gran Bretagna

Berlin Brands Group UK Limited
PO Box 42
272 Kensington High Street
London, W8 6ND
United Kingdom

